

S. W. BONSTALL.
TRUNK.

APPLICATION FILED JUNE 28, 1907.

923,807

Patented June 8, 1909.

2 SHEETS—SHEET 1.

Fig. 1.

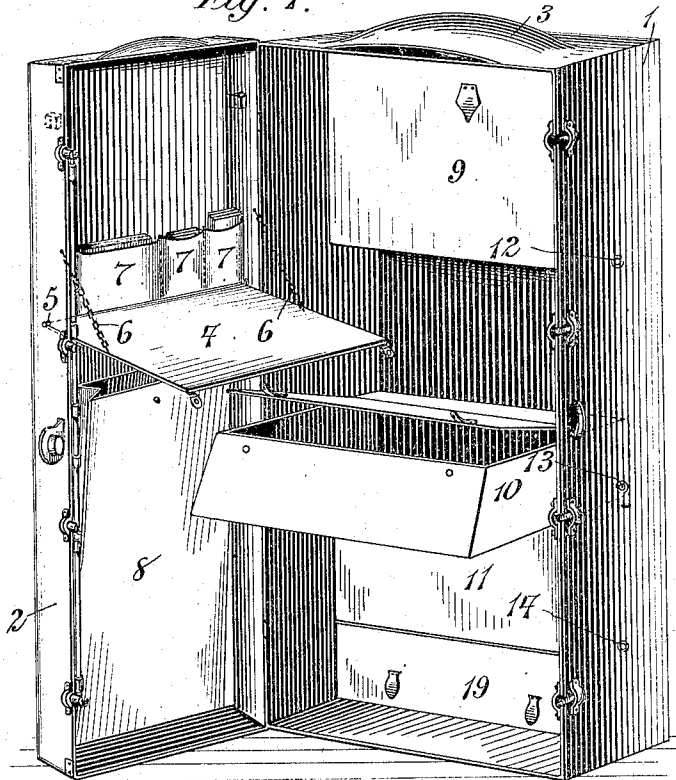

Fig. 2.

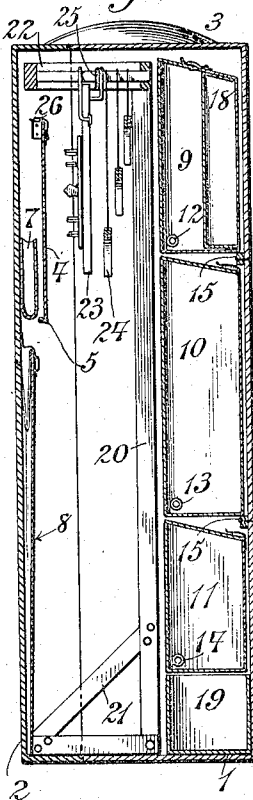

Fig. 3.

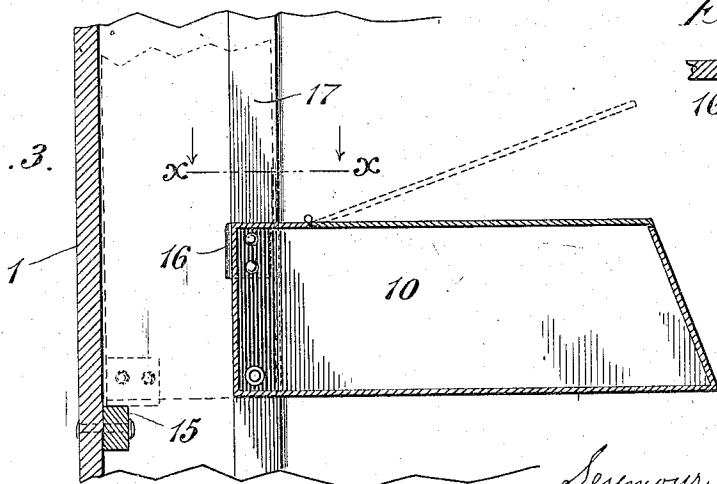
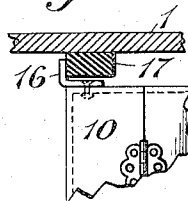

Fig. 4.



Witnesses:
Edward J. Dowland,
May A. Butler

Seymour W. Bonsall
Inventor

By his Attorney H. A. Mackay

S. W. BONSALE.
TRUNK.
APPLICATION FILED JUNE 28, 1907.

923,807.

Patented June 8, 1909.
2 SHEETS—SHEET 2.

Fig. 5.

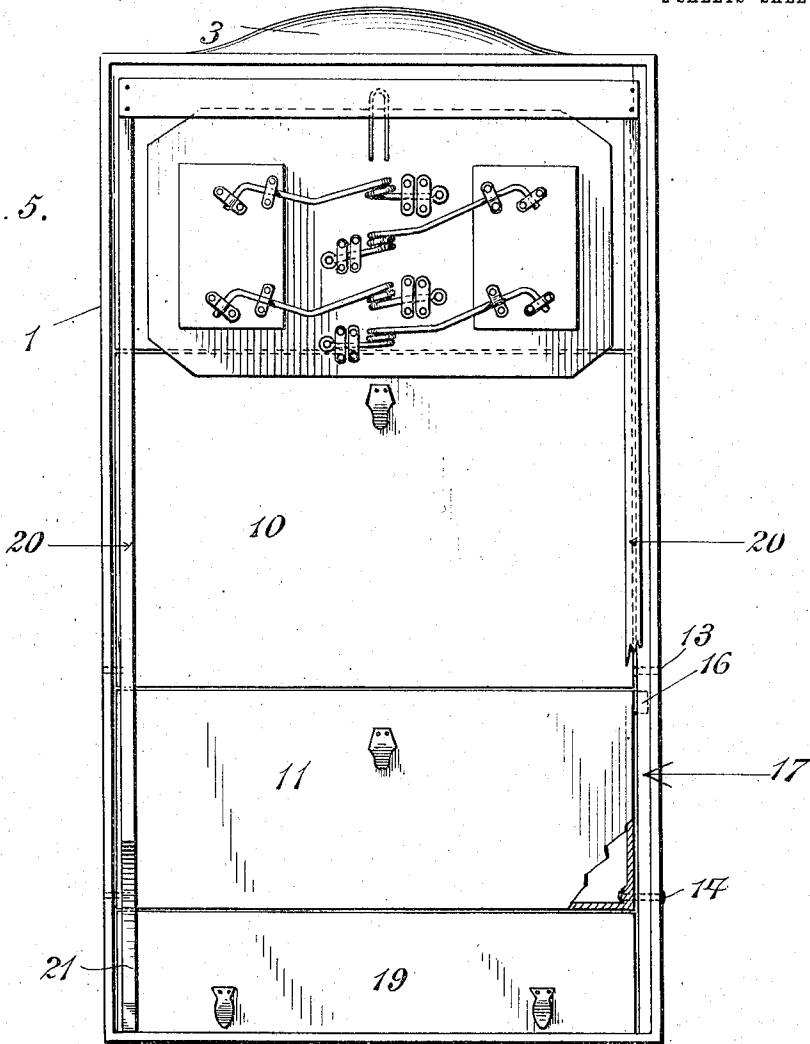
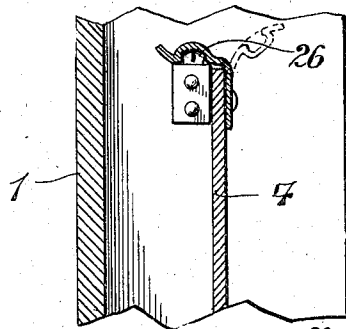

Fig. 6.



Witnesses:
Edward G. Dowling,
May A. Butler

Seymour W. Bonsall
Inventor

By his Attorney H. M. Mackay

UNITED STATES PATENT OFFICE.

SEYMOUR W. BONSALE, OF NEW YORK, N. Y.

TRUNK.

No. 323,307.

Specification of Letters Patent.

Patented June 8, 1909.

Application filed June 28, 1907. Serial No. 331,321.

To all whom it may concern:

Be it known that I, SEYMOUR W. BONSALE, a citizen of the United States, residing in the borough of Manhattan, city, county, and State of New York, have invented a certain new and useful Improvement in Trunks, of which the following is a specification.

The present invention has particular relation to an improved form of trunks for use by persons who travel a great deal and who desire to carry with them a large variety of articles, but who do not desire to carry with them a large wardrobe.

An important feature incident to my present invention is found in the provision of means whereby all the advantages of a bureau-trunk can be secured together with those incident to that class of wardrobe trunk in which garments are suspended in the trunk ready packed and whereby these advantages are obtained while securing the utmost stability at all times without any danger of the trunk being tipped over when the separate drawers or compartments are brought into position for unpacking.

The invention is illustrated in the accompanying drawings wherein—

Figure 1 shows in perspective the trunk open with the wardrobe attachment removed, Fig. 2 is a central vertical section of the trunk when closed and ready for shipment, Fig. 3 is a detail in section showing mode of use of tilting compartments, Fig. 4 is a detail of the supporting means preferably used in connection with said compartments and is a section on the line $x-x$ of Fig. 3, Fig. 5 is a front view of the trunk with the cover removed and a part of the suspending device broken away and Fig. 6 is a sectional detail of a preferred fastening for the writing desk attachment.

In the drawings, which are to be understood as showing a preferred embodiment of the invention, the main body of the trunk is shown at 1 and the cover at 2. I prefer to provide the trunk with a swelling or projection 3 at the top end whereby no mistake will be possible in placing the trunk right side up when about to unpack it.

In the condition shown in Fig. 1, the trunk presents the advantages of a combined bureau or chiffonnier and a writing desk. In order to accomplish this the inside of the cover of the trunk is provided with a flap 4 hinged within the cover at the two extremities of its lower edge as shown at 5. The

chains 6 support the flap when lowered to form a support for writing and in the space behind the flap, I place suitable receptacles 7 for writing materials, memoranda and like articles, which receptacles may be of any construction appropriate to the space within which they are contained. Below the writing desk flap 4 the cover is occupied preferably by port-folios for larger papers. It is within my invention to utilize this space in any desired manner.

In order to get all the advantages of a bureau trunk combined with those of a trunk set on end as shown, and at the same time to avoid any tendency to tilt the trunk over when the drawers or other receptacles are opened, I provide receptacles adapted to be drawn forward out of the back portion of the interior of the trunk and so located and constructed that when they are drawn forward their center of gravity will be within the body of the trunk and over its base so that all tendency to tilt the trunk forward is prevented. While I do not limit myself to any particular type of receptacle to be drawn forward in this manner, I prefer to use the tilting boxes 9, 10 and 11 substantially as shown in Figs. 1, 2 and 3. These boxes are preferably of equal depth (from left to right in Fig. 2) and when the trunk is to be closed they occupy the position shown in Fig. 2 one over the other, filling the bottom or rear portion of the trunk body. Each of these boxes is separately pivoted as shown at 12, 13 and 14 at the side of the trunk body and have a slanting front as shown to prevent interference with the swinging of each box backward and forward.

As shown at Fig. 2, when the trunk is to be closed, the top of each box 9, 10 and 11 lies parallel with the rear of the trunk body where it may be supported by an appropriate stop or ledge 15, or otherwise. To gain access to any one of these boxes it is only necessary to draw it forward and tilt it down on its pivot into the position shown in Figs. 1 and 3. In this position all the contents of each box are easily available and the box is held firmly by means of a bracket stop 16 which bears against the securing strip 17 fastened within the trunk body. Other supporting means may be used without departing from my invention. In this position the whole trunk is perfectly stable, as the boxes when drawn forward

are preferably made so short as not to extend far out of the trunk body, thus bringing the center of gravity well within the base of the trunk body. At the same time these

8 boxes are long enough to provide ample room for laying garments flat in a horizontal position while packing them.

If desired the drawer 18 may be fitted into one or more of the tilting boxes and a common sliding drawer 19 may be made to rest upon or near the floor or bottom of the standing trunk.

The arrangement above described leaves available within the trunk when closed a considerable space which I prefer to employ for the accommodation of a removable suspending frame 20, preferably entirely open at the sides all the way to the bottom where a brace 21 may be used. The top of the frame may be extended forward close to the inside of the cover and over the top of the flap 4 in its raised position. This construction of frame makes it possible to get at any one article of clothing which is hung upon it from the side without disturbing the other garments.

The frame 20 carries a horizontal suspending rod or bar 22 upon which a variety of hangers 23, 24 for trousers, coats or dresses may be hung so as to slide backward and forward in a manner well understood in wardrobe trunks. These clothes are secured by a friction clutch arrangement shown at 25, or otherwise in a well known manner. When the trunk is unpacked the frame 20 with all the garments which it supports can be withdrawn and put away in a corner or

in a closet to serve as a wardrobe, leaving the remainder of the trunk equipment to serve as a combined bureau and writing desk as shown in Fig. 1. 40

When the trunk is packed the boxes are tilted back as shown in Fig. 2, the flap 4 is raised and is fastened at its top either by a strap, a button fastener shown at 26, or otherwise as desired (see Fig. 6). The frame is then placed in position in the trunk body with its back against the bottoms of the tilting boxes and the cover being closed and locked, the trunk is ready to be shipped. 45 50

The above construction makes it possible to provide a very compact stable and convenient combination trunk capable of answering for a variety of uses and of accommodating a considerable variety of articles. This is accomplished with as little complication in the construction as possible and the simplicity of the means employed insures the lasting qualities of the trunk. 55 60

What I claim is—

A combination trunk comprising a casing adapted to stand upright on end and a number of tilting receptacles pivoted one over the other in said casing, each of said receptacles being adapted to tilt back snugly against the trunk bottom, or, if desired, to tilt forward with its center of gravity over the supporting end of said casing, substantially as described. 65

SEYMOUR W. BONSALL.

Witnesses:

GEORGE F. BRADLEY,
SAM. J. SUMNER.