

- [54] **BLOOD SAMPLE CONTAINER**
- [76] Inventor: **John M. Dick**, 5360 Burlingame Avenue, Los Angeles, Calif. 90620
- [22] Filed: **June 15, 1970**
- [21] Appl. No.: **46,168**
- [52] U.S. Cl. **210/516, 210/DIG. 23, 433/45**
- [51] Int. Cl. **B01d 21/26**
- [58] Field of Search **210/516-518, 210/361, 380, 130, DIG. 23; 233/45**

Primary Examiner—Robert L. Lindsay, Jr.
 Attorney—George J. Netter and Kendrick and Subkow

[57] **ABSTRACT**

A generally tubular shaped container includes an expandable head valve member and retaining clip assembly therewithin. On centrifuging the clip is disengaged from the valving member, permitting it to expand toward the inner walls of the container to form two separate compartments, one for the blood cells and one for the serum. During centrifuging, the valve member head is temporarily deformed at its edges an amount sufficient to allow the cells to move therepast, and at the conclusion of centrifuging the head resumes sealing engagement with the container wall. The serum may then be simply poured out of the container for testing.

In a further aspect, the tubular container has a spring-loaded valving member disposed at substantially the mid-point thereof. In a still further form, filter means are located within a test tube, through which serum can pass, but blood cells cannot.

[56] **References Cited**

UNITED STATES PATENTS

1,528,480	3/1925	Henderson	210/516
2,963,162	12/1960	Shaw et al.	210/130 X
2,995,253	8/1961	Belgarde et al.	210/130 X
3,300,051	1/1967	Mitchell	210/361 X
3,508,653	4/1970	Coleman	210/516 X
982,328	1/1911	Wheeler	210/516
3,583,230	6/1971	Patterson	210/361 X

6 Claims, 7 Drawing Figures

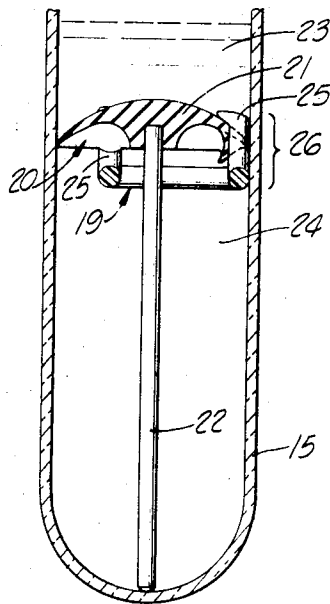

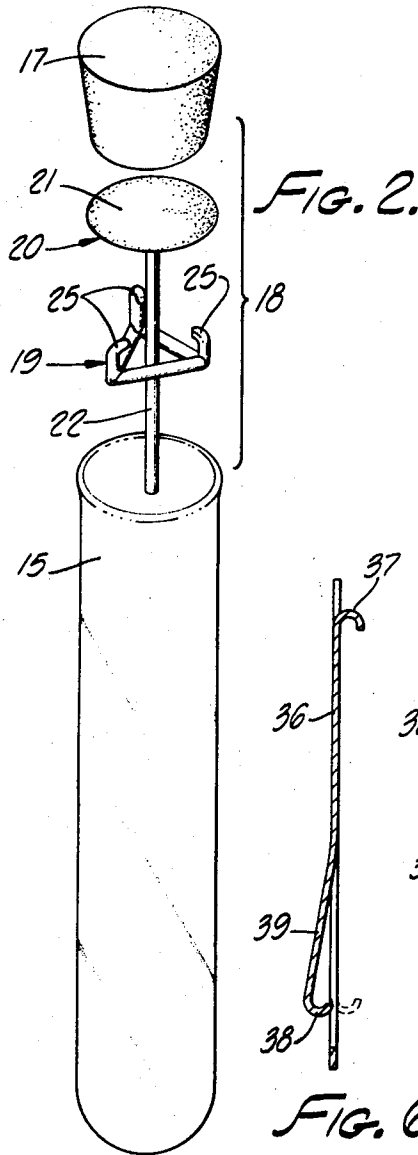
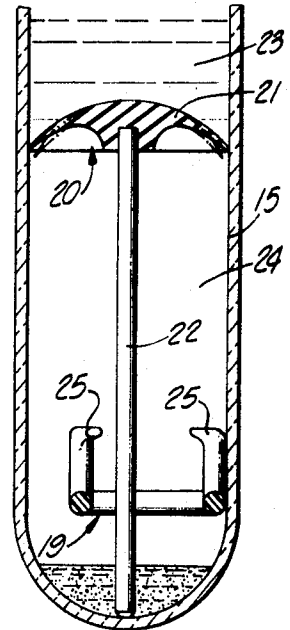
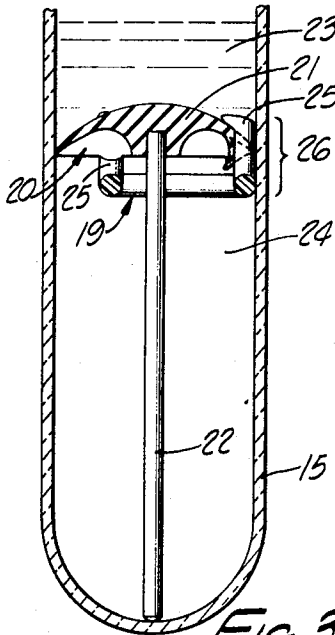
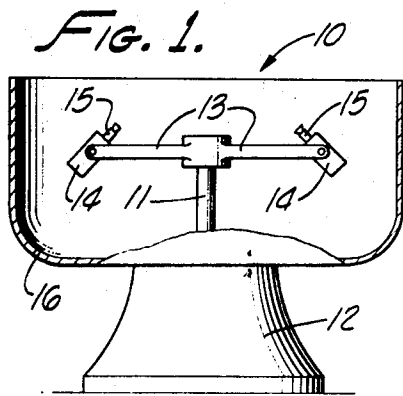

FIG. 2.

FIG. 3.

FIG. 4.

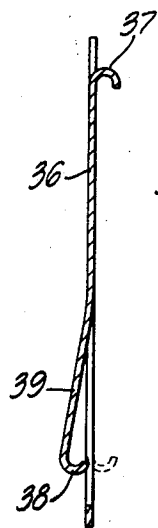

FIG. 6.

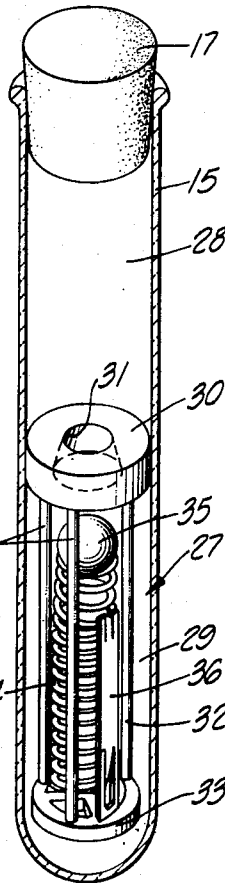

FIG. 5.

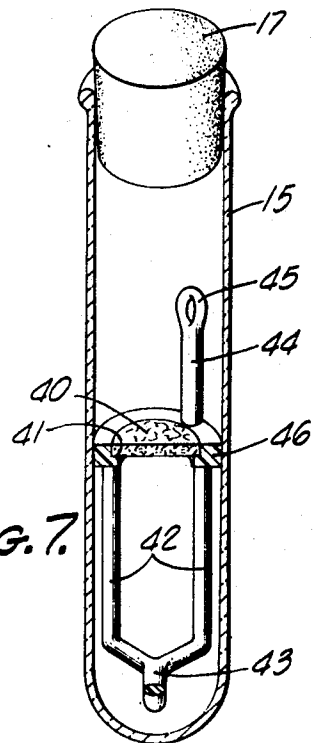

FIG. 7.

INVENTOR
JOHN M. DICK

BY KENDRICK and SUBKOW

George J. Ketter
ATTORNEYS

BLOOD SAMPLE CONTAINER**BACKGROUND OF THE INVENTION**

The present invention pertains generally to contain- 5
ers for blood samples, and, more particularly, to such
containers having separate compartments into which
serum and blood cells are respectively received during
centrifuging.

The frequent practice is for blood samples of a pa- 10
tient to be taken at a doctor's office and then transmit-
ted to a laboratory facility where analytical tests are
conducted. Prior to transmitting the blood samples to
the laboratory, it has been found advantageous to centri-
fuge the sample for separating the cells from the 15
serum and thereby obtaining serum for test substan-
tially free from cells. In the past, centrifuging has been
accomplished by placing a blood sample in a conven-
tional test tube, inserting the tube and sample in the
centrifuge, and, after separating the cells from the 20
blood serum, the serum (which is at the upper part) is
then poured off, leaving the cells. This essentially hand
technique involves a relatively large amount of time on
the part of the doctor and/or nurse in the office, which
could more profitably, and with benefit to the patient, 25
be spent on other matters.

OBJECTS AND SUMMARY OF THE INVENTION

There is provided in accordance with the practice of
the present invention, a blood sample container which 30
on centrifuging automatically separates the blood and
serum into separate compartments.

Another object of the invention is the provision of a
blood sample container which, after centrifuging to 35
separate the cells from the serum, can be transmitted
as is, without further special handling or processing.

In the practice of the present invention there is pro-
vided a generally tubular shaped container for the
blood sample including an expandable head valve 40
member and retaining clip assembly therewithin into
which the whole blood is initially inserted. On centri-
fuging the clip is disengaged from the valving member,
permitting it to expand toward the inner walls of the
container to form two separate compartments, a lower
one primarily for blood cells and an upper one contain- 45
ing only serum. During centrifuging, the valve member
head is temporarily deformed at its edges an amount
sufficient to allow the cells to move therepast, and at
the conclusion of centrifuging the head resumes sealing
engagement with the container wall. The serum may 50
then be simply poured out of the container for testing.

A further form of the invention includes a tubular
container with spring-loaded valving member disposed
at substantially the mid-point thereof which is held 55
initially open by means of a detachable clip. On centri-
fuging, the valving member is held open under the action
of centrifugal force to permit the cells to move to the
container bottom, and at the close of centrifuging the
valving member closes, separating the serum in the 60
upper compartment from the cells in the lower one.
The clip is detached during centrifuging. As in the first
form, the serum may be poured out of the container
while the cells are retained in the lower compartment.

A still further form of the invention includes a typical 65
test tube with a filter means located midway, through
which serum can pass, but blood cells cannot. On centri-
fuging, the serum is filtered and the cells remain

above the filter as residue. At the conclusion of centri-
fuging, the filter means and residue are removed and
discarded, leaving the serum in the tube for testing.

DESCRIPTION OF THE DRAWINGS

FIG. 1 is a sectional, elevational view of a centrifuge
including blood sample containers of the present inven-
tion.

FIG. 2 depicts in perspective view a preferred form
of the invention in disassembled form.

FIG. 3 illustrates a sectional, elevational view of the
invention as shown in FIG. 2 in assembled form prior
to centrifuging.

FIG. 4 is a sectional, elevational view of the blood
sample container of FIG. 3, shown immediately after
initiation of centrifuging.

FIG. 5 is a sectional, elevational view of a further
form of the invention.

FIG. 6 illustrates a retaining clip for use with the in-
vention of FIG. 5.

FIG. 7 depicts a still further form of the invention.

DESCRIPTION OF A PREFERRED EMBODIMENT

It is basic to the subject invention that a container for
carrying a sample of blood in accordance with the prac-
tice of this invention is to be centrifuged and the serum
and blood cells separated thereby with the cells con-
fined to one portion of the container while the serum
is confined in another. Also, it is an important advan-
tage of this invention that the container after centrifug-
ing may be readily shipped or mailed to a testing labo-
ratory as is without further special handling or process-
ing by the doctor.

FIG. 1 illustrates a centrifuge 10 of conventional de-
sign including a vertically extending axle 11 driven by
a rotative power source (not shown), located in a sup-
port base 12. The upper end of the shaft 11 is secured
to two or more radially extending arms 13, the outer
ends of which carry suitable receptacles 14 for the
blood sample containers 15. An open top bowl-like
member 16 conventionally surrounds the entire shaft,
arms 13 and blood sample containers 15 as shown. In
operation, the power source in the base 12 rotates the
shaft and associated apparatus at a high rate of speed
which tends to move the more dense blood cells within
the blood sample toward the bottom of the blood sam-
ple container due to the action of centrifugal force.

Most small-sized centrifuges are designed for use
with sample containers in the general shape of a test
tube and for that reason the general outward character-
istics of the container of this invention will have that
same shape. It is to be understood, however, that other
external container geometries may be adopted and still
be within the spirit of this invention.

Reference is now made to FIG. 2 and to the detailed
construction of a preferred embodiment of the inven-
tion in which the main container body consists of a typ-
ical glass test tube 15 which may be closed by a conven-
tional rubber or cork stopper 17. A centrifuging valve
means identified generally as 18 in exploded form, in-
cludes two main parts, a releasable clamp 19 and a
gravity actuated valving member 20.

More particularly, the valving member 20 includes a
frusto-conical head 21 of circular periphery, which is
received on the end of a rod 22 of such length that
when the valving member assembly is fully received
within the test tube, the head 21 is located at substan-

tially the midpoint of the test tube long dimension. The head 21 is constructed of a resilient plastic or rubber which is more dense than the whole blood, blood cells or serum thereof which enables the head to undergo a temporary deformation during centrifuging to produce a valving action that will be described below. The head diameter is such that in a normal rest condition within the tube 15, as shown in solid line depiction in FIGS. 3 and 4, the head edges sealingly contact the inner wall of the tube in a continuous manner and separate the tube into upper and lower chambers 23 and 24, respectively.

The clamp 19 includes a plurality of arms joined together at their ends to form a triangular base enclosing a space through which the rod 22 is received. A plurality of upstanding hooks 25, attached to the base of the clamp 19 extend in the same direction away from the base and are so dimensioned that they can be received about and engage the peripheral margins of the frustoconical head 21 as shown in FIG. 3 generally at 26.

Prior to insertion of the valve means 18 within the tube 15, the clamp 19 is engaged with the head 21, which moves the head margins inwardly a sufficient amount so that the entire assembly means may be readily inserted into the test tube 15. That is, the clamp lateral dimensions are less than the inner diameter of the test tube, whereas, as was indicated above, the at-rest, unclamped diameter of the head 21 is slightly larger than the test tube cavity in order to permit sealing engagement with the test tube inner wall.

In use, the assembly 18 with the clamp 19 constricting the head 21 is inserted into the tube and the blood sample to be centrifuged is placed in the tube 15 filling chamber 23 and substantially all of chamber 24. The tube is then placed in the centrifuge. During centrifuging the clamp 19 moves from a position of head engagement shown in FIG. 3 to a lower position as shown in FIG. 4, due to the force exerted thereon. Also, at this time the centrifugal force deforms the margins of the resilient head inwardly to the dotted line position in FIG. 4, which permits the more dense blood cells to move to the lower chamber 24 of the tube. The latter process continues until substantially all the cells have been centrifuged to the bottom chamber of the tube, at which time the centrifuge is stopped. In the rest position the marginal edges of the head 21 reassume sealing contact with the inner walls of the tube 15 and the entire blood sample container may be simply removed from the centrifuge as is and sent to a laboratory by messenger or mail, as desired, without further special handling or processing.

FIG. 5 depicts an alternate form of this invention including a spring operated valve means 27 for separating the test tube 15 into an upper compartment 28 for serum and a lower one 29 for blood cells. The valve means comprises an annular valve member 30 with a tapered opening 31, which member closely fits within the test tube bore. A plurality of rodlike supports 32 interconnect the valve member 30 and a dislike pedestal 33. Within the space defined by the supports 32 a coil spring 34 has one end engaging the pedestal upper surface and its end contacting a ball closure member 35 of such diameter that when received within the opening 31 it closes the same. When the spring is uninhibited, it seats the ball 35 within the opening 31.

A generally flat, elongated retaining clip 36 is constructed of a springlike metal or plastic. A first hook-

like ear 37 is formed from the clip body, and a second hooklike ear 38 faces on the same side of the clip as the first ear. The ear 38 is at the end of a lever arm 39 formed from the clip body and bent such that in the relaxed state the ear 38 is retracted below the clip body surface as shown in FIG. 6.

In use the clip 36 is mounted onto the spring 34 by forcing the ear 38 through the opening in the clip body wall and with both ears then extending on the same side of the clip the ears retainingly engage the spring loops holding the spring partially coiled as illustrated in FIG. 5. The entire valve assembly 27 is then inserted into the tube 15, with the valve initially held in the open condition by the clip 36. The whole blood sample fills the lower chamber 29 and substantially all of chamber 28.

On centrifuging of the sample, the ball closure member 35 further compresses the spring 34 disengaging the retaining clip which falls to the side. At the conclusion of centrifuging the spring, which is now free of the retaining clip, seats the ball 35 within the opening sealing the lower chamber 29 containing blood cells from the upper chamber 28 containing only serum.

A still further embodiment is that shown in FIG. 7 which relies on a filter for maintaining separation of the cells and serum. An annular member 46 has an outer diameter closely approximating the inner diameter of the test tube 15. A porous filter element 40 is received within the central opening of 39 and seats against a shoulder 41, thereof. The filter element is so constructed as to permit serum to pass through while restricting the passage of blood cells. A plurality of elongated supports 42 are affixed to the lower surface of the member 39 and extend downwardly therefrom to terminate at a common junction or pedestal 43. A retracting means 44 is secured to the upper annular surface and terminates in an eyelet 45.

Prior to use, the entire filtering assembly is merely inserted into the tube with the pedestal 43 bottoming, or approximately so, in the tube. The blood sample is poured into the tube, the tube is stoppered and centrifuged. During centrifuging the serum passes through the filter element 40 while the cells are trapped in the upper part. When the container is received at the testing facility, it is unstoppered and by the use of a hook-ended device (not shown) inserted into eyelet 45, the entire filtering mechanism is removed. During such removal, due to the close fit of the tube and annular member 39, the cells are also removed and the tube inner walls wiped clean, leaving the serum for testing.

Although not intended to be limitative on the present invention, in the usual case the containers 15 are vacuumized and the blood sample is emptied directly into the container from the hypodermic via its needle. This is especially advantageous in the use of the filter device of FIG. 7, since the low pressure below the filter element 40 will tend to draw the serum through the filter, thereby reducing, if not eliminating the centrifuging.

I claim:

1. Container apparatus actuatable by centrifuging force to segregate materials of differing density composing a liquid sample carried thereby, comprising in combination:

- a test tube;
- a support rod;
- a pliable sealing member received onto one end of the support rod, said sealing member having trans-

verse dimensions greater than the test tube inner diameter; and

a clip received onto the support rod and including clasps for engaging the sealing member margins from the rod side and constricting them inwardly; said rod, sealing member and clip being received within the test tube with the rod engaging the tube bottom whereby during centrifuging the clip is forced off the sealing member and the sealing member edges are bent toward the tube bottom allowing denser materials of the liquid sample to pass.

2. Container apparatus actuable during centrifuging for separating blood cells from serum composing a blood sample carried thereby, comprising in combination:

- a test tube;
- a disc valve seat fittingly received within the test tube and including an opening passing therethrough;
- support members connected to the valve seat and extending downwardly in the tube;
- pedestal means secured to the lower ends of said support members;
- a coil spring having one end engaging the pedestal means and extending upwardly toward the valve seat; and
- a closure member actuated by the free end of the spring to close the opening in the valve seat when the spring is in a relaxed state.

3. Container apparatus as in claim 2, in which there is further provided clip means for engaging selected loops of said spring for maintaining the spring initially

in a compressed state.

4. A fluid sample container adapted for receipt within a centrifuge, comprising in combination: test tube container means having an open end and a closed end; and

force actuated valve means carried within said container means, said valve means including, a resiliently deformable head element of dimensions slightly exceeding those of the container means transverse internal cavity received within said container means, and

support means connected to said head element and resting on the inner closed end of said container means for holding the head element spaced from said container means closed end, the peripheral margins of said head element deforming during centrifuging to allow suspended materials in the fluid sample to pass into the container means cavity between said head element and said container means closed end.

5. A fluid sample container as in claim 5, in which the head element is of frusto-conical shape, the convex part thereof facing toward the container means open end.

6. A fluid sample container as in claim 5, in which a retaining clip is clampingly received onto the head element deforming the element edge margins sufficiently to allow the fluid sample to pass around said margins into the lower reaches of said container means, said clip being disengaged from said head element by the centrifuging force.

* * * * *

35

40

45

50

55

60

65