

June 24, 1930.

R. J. WENSLEY

1,765,554

TALKING TELEVOX

Filed March 26, 1929

2 Sheets-Sheet 1

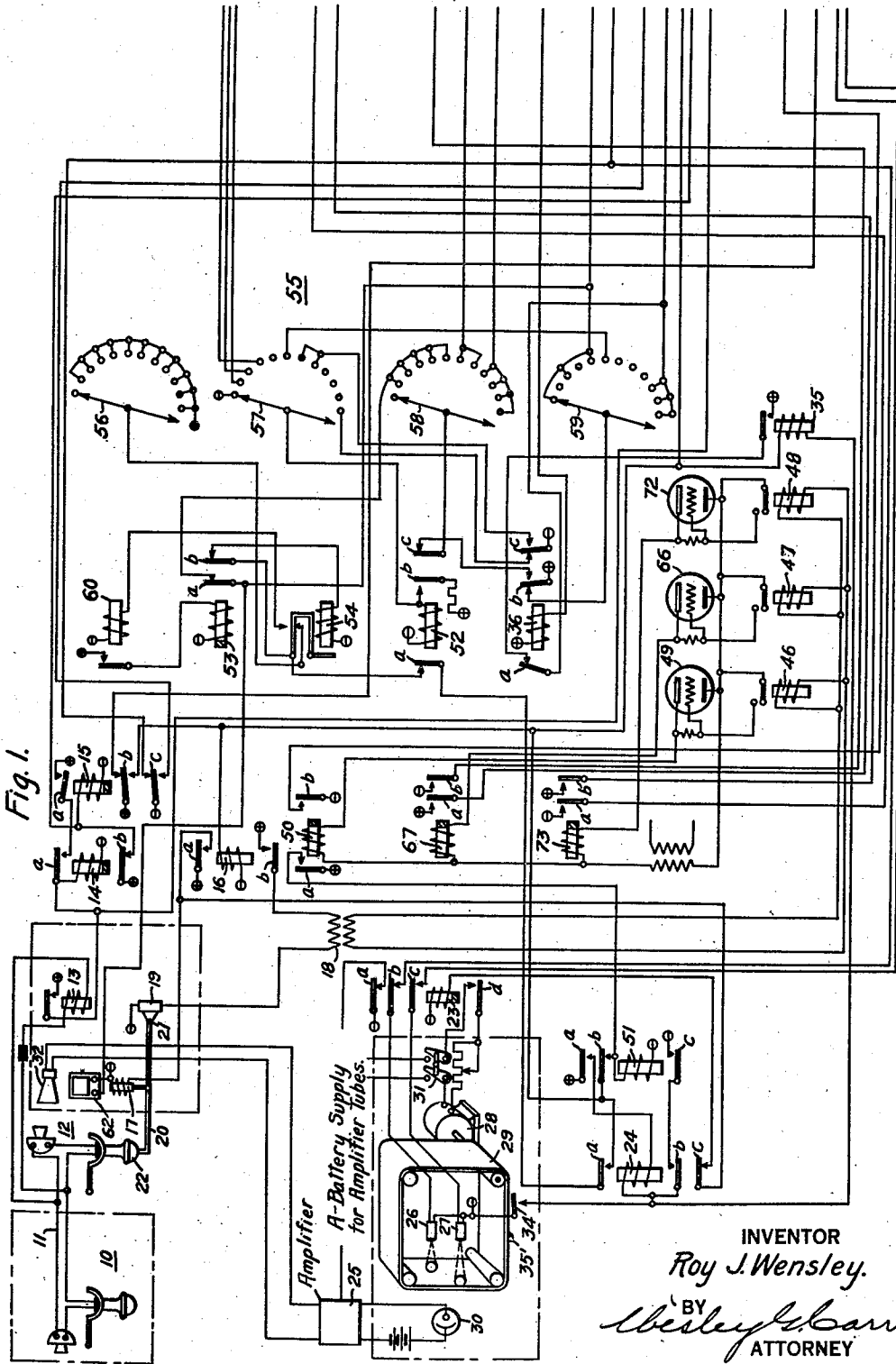

INVENTOR  
Roy J. Wensley.  
BY  
*Wesley & Carr*  
ATTORNEY

June 24, 1930.

R. J. WENSLEY

1,765,554

TALKING TELEVOX

Filed March 26, 1929

2 Sheets-Sheet 2

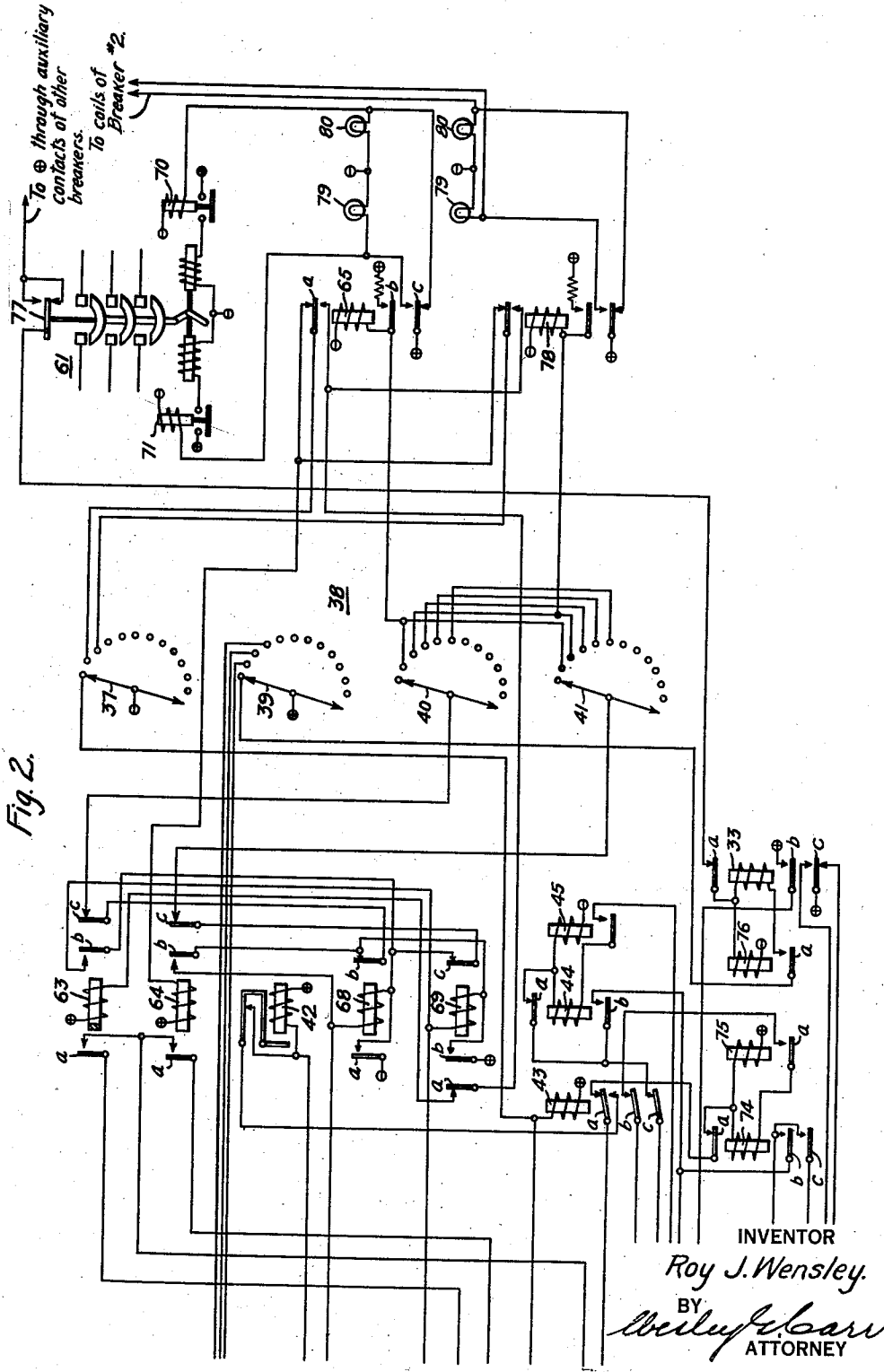

Fig. 2.

INVENTOR  
Roy J. Wensley.  
BY  
*Wells, Barrett & Co.*  
ATTORNEY

# UNITED STATES PATENT OFFICE

ROY J. WENSLEY, OF EDGEWOOD, PENNSYLVANIA, ASSIGNOR TO WESTINGHOUSE  
ELECTRIC & MANUFACTURING COMPANY, A CORPORATION OF PENNSYLVANIA

## TALKING TELEVOX

Application filed March 26, 1929. Serial No. 350,103.

My invention relates to control and signalling systems, and, in particular, to control systems of the type adapted to utilize existing telephone circuits for controlling a plurality of apparatus units, such as circuit breakers or the like, from a distance, and transmitting a signal indication of the condition of such units.

The general object of this invention is to improve upon the system disclosed in my co-pending application, Serial No. 226,116, filed Oct. 14, 1927, for "Televox controller and supervisor." In said application, a system of control and signalling is disclosed which makes possible the control and supervision of distant apparatus units over standard telephone circuits.

It is the particular object of this invention to improve upon the system of said application in the means for identifying the distant station when the telephone at the latter is called by an attendant at the control station. In the previous system, the called station was identified by a characteristic code of buzzer tones. In the present invention, I propose to provide means for giving vocal response from an unattended station to the calling attendant at the central control station. In addition, it is an object of this invention to provide means for automatically calling the attendant at the control station by telephone, in the usual manner, when an automatic operation occurs at the distant substation. This call will be made, according to my invention, by automatic speech-reproducing means which will be caused to function upon the automatic operation of any unit, such as a circuit breaker.

Although the system of my invention was devised chiefly for controlling circuit breakers of an electric-distribution system, in various substations thereof, from the dispatcher's office at the central station, it is obvious that numerous other applications of my invention are possible.

My invention is described herein in connection with an electric distribution system having automatically operable circuit breakers but it is to be understood that it is not to

be limited by the description of the specific embodiment mentioned.

For a full understanding of my invention, it will be necessary to refer to the accompanying drawings, Figs. 1 and 2 of which jointly illustrate diagrammatically an operative embodiment of the invention.

The various elements utilized in the embodiment illustrated will be described in the course of the following description of operation.

Referring to Fig. 1, the dispatcher's telephone is illustrated at 10 and is adapted to be connected, through the usual telephone system indicated schematically at 11, to the substation telephone 12. I wish to emphasize, at this point, that the telephone apparatus utilized in connection with the system of my invention is standard in every respect and that no electrical connections thereto are necessary. The only adjunct to such equipment is the automatic receiver-lifting mechanism which will be described later, but this is not electrically connected to the telephone equipment, and the mechanical relation therebetween is such that it may be easily disconnected.

It must be assumed, in the first place, that the dispatcher, through the usual central office, has obtained a connection from his telephone 10 to the substation telephone 12. The complete circuits and auxiliary apparatus associated with the telephone equipment have been omitted for the sake of simplicity, since they are standard, and well known. When this connection has been effected, the substation telephone bell (not shown) will be energized by the usual alternating ringing current. This current also energizes a so-called ring-down relay 13 which has its winding connected across the telephone circuit 11. While this relay is directly connected to the circuit 11, it is a connection, such as the telephone companies supply as standard equipment upon request of the subscriber.

When the ring-down relay is energized by the ringing current, an obvious energizing circuit for a slow-release relay 14 is completed at the front contact and armature of the relay 13, from positive battery through

said armature and the winding of the relay 14, to negative battery. In the drawing, I have adopted the convention of indicating positive and negative battery terminals by plus and minus signs within small circles. Although these symbols are duplicated in the drawings, it will be understood that a single source of direct current, such as a storage battery or generator, may be employed at the dispatcher's office and the substation, the various voltages required being obtained from said source by any convenient well-known means.

It should be noted at this point that a relay 15, associated with the relay 14, is normally energized in a circuit including the back contact and *b* armature of the relay 14, as long as the system is not operating. The relay 15 is also a slow-release relay, i. e., it does not release its armatures until after the lapse of a short time interval following the opening of its normally closed energizing circuit by the energization of the relay 14. When the relay 15 finally releases its armatures, a locking circuit is completed for the relay 14, through the *a* armature and front contact of said relay and the *a* armature and back contact of the relay 15, to positive battery. Thus, when the ring-down relay is energized by the telephone ringing current, the relay 14 is energized and locked in that position, and the relay 15 is deenergized. The slow-release characteristic of the relay 15 requires that relay 14 be energized for a definite interval before the substation equipment will be placed in operation. This feature avoids false operations resulting from inadvertent or accidental energization of the substation telephone bell-ringer.

The deenergization of the relay 15 connects positive battery, through the *b* armature of said relay and its back contact, to the winding of a relay 16, the other terminal of which is connected to negative battery. The resulting energization of the relay 16 completes a circuit at its *a* armature and front contact, from positive battery, through a receiver-lifting magnet 17, to negative battery. The energization of the receiver-lifting magnet 17 causes the receiver of the substation telephone 12 to be lifted from its hook switch to establish communication between the dispatcher's office 10 and the substation. The relay 16, at its *b* armature and front contact, completes a circuit including a winding of an induction coil 18 and a microphone 19, which is connected to the substation telephone receiver through a tubular arm 20 pivoted at 21 and terminating in a bell 22 for cooperation with the receiver at the substation telephone.

The relay 16 also causes positive battery to be supplied through its *a* armature to the winding of a relay 23 through a circuit including the *c* armature and back contact of a

relay 24. The relay 23 is thereby energized and, at its *a* armature and front contact, completes a circuit from negative battery for the thermionic amplifying tubes of a standard amplifying unit 25, the purpose of which will become apparent later. The relay 23 is adapted to prepare, at its *b* and *c* armatures, circuits for electric lamps 26 and 27 which constitute parts of a speech-reproduction mechanism of a well-known type. This mechanism utilizes a film record of sound waves, and, through the agency of a photo-electric cell, is adapted to reproduce the speech recorded on the film. In the system of my invention, I employ a motor 28 for driving a film 29 through the standard drive and gate mechanism (not shown). A photo-electric cell 30 is adapted to be energized by the light passing through the film 29 from either of the lamps 26 and 27. The circuit of the motor 28 is controlled through the *d* armature and front contact of the relay 23. A manual switch 31 serves to control the connection of the motor circuit to the current source.

According to my invention, the film 29 bears two speech records, one of which is adapted to be illuminated by each of the lamps 26 and 27. One speech record may be that identifying the substation, and, when reproduced, may be caused to emit audibly the name and number of the substation. The speech record is translated into electric current by the photo-electric cell 30, the output of which is amplified by the amplifier 25 and supplied to a loud speaker 32 which is placed adjacent to the transmitter of the substation telephone 12. A relay 33 (Fig. 2), at its *c* armature, controls the lamps 26 and 27, and the position of said armature determines which of said lamps is to be energized.

The relay 33 is adapted to be controlled by means which will be explained later, to cause an appropriate message to be emitted. When the relay 33 is deenergized, the circuit prepared at the *c* armature of relay 33 for the lamp 27 will be complete from positive battery, by the *c* armature and back contact of relay 33, to the *c* armature and front contact of relay 23, to the lamp 27 and negative battery. The lamp 27 will thus be energized to illuminate the left-hand portion of the film 29 and the speech recorded upon that portion of the film will thereby be reproduced in the speaker 32 and transmitted over the telephone circuit to the dispatcher at the central station 10.

The speech recorded on the left-hand half of the film, may appropriately be something of the following nature, "This is the Fourth Avenue Substation of the Electric Light & Power Company, Williams 2573." It is thus possible for the operator at the central station to be informed as to the particular station with which he is actually connected by the telephone operator. This message is re-

corded on the length of the film 29 and, when the message has been conveyed once, an auxiliary switch 34, associated with the film in any convenient manner, is adapted to be closed, for example, by a projection 35' carried by the film. When the message has been transmitted once and the switch 34 is closed, negative battery is connected to the lower terminal of a relay 35. The upper terminal of the winding of this relay obtains positive battery from the back contact and *b* armature of the relay 15. The relay 35 is thereupon energized.

At this point it is necessary to explain that a relay 36 is normally energized in a circuit including the winding of said relay, the first contact and wiper 37 of a step-by-step selector switch 38 to negative battery. This selector switch is well known in the art and its wipers 37, 39, 40 and 41 are adapted to be actuated from contact to contact by a stepping magnet 42 which, when energized, operates a ratchet and pawl against the tension of a spring and, when deenergized, permits the spring, through the ratchet and pawl, to advance the shaft on which the wipers are mounted, so that the wipers move to the next succeeding contact. Another relay 43 is also energized in a circuit including the first contact and wiper 37 of the switch 38.

Thus, when the relay 35 is energized by the closing of the switch 34, a circuit is completed from positive battery, through the front contact and armature of relay 35, the front contact and *a* armature of the relay 36, and *c* armature and front contact of relay 43 and the *a* armature and back contact of a relay 44, to the winding of a relay 45 and negative battery. The relay 45 is energized by the completion of the circuit just traced and, at its armature and front contact, prepares a series energizing circuit for the relays 44 and 45. This circuit is traceable from negative battery, through the winding of relay 45, the winding of the relay 44 and the armature and front contact of the relay 45, to positive battery at the back contact of armature *b* of relay 15. So long as the original energizing circuit of the relay 45 is maintained, however, it will be seen that both terminals of the winding of the relay 44 will be connected to positive battery. The relay, therefore, will not be energized, since the terminals of its windings are at the same potential.

When the switch 34 is permitted, by the passage of the projection 35', to assume its normal open position, the relay 35 is deenergized, and the original energizing circuit for the relay 45 is interrupted at the armature of the relay 35. This permits current to flow from negative battery through the windings of the relays 45 and 44 in series, to positive battery through the *b* armature and back contact of relay 15. The relays 44 and 45 are thus energized in series.

Nothing further happens until the substation identifying message has again been reproduced, and the switch 34 closed the second time. When this occurs, a circuit is completed for the relay 35 as previously described, and the latter again supplies positive battery to the front contact and *a* armature of relay 36 to the *c* armature and front contact of the relay 43. Since the relay 44 is now energized, however, the circuit continues through the *b* armature of the relay 44 instead of the *a* armature, as in the first instance. The circuit then extends to the upper terminal of the winding of relay 15, through the winding of said relay, to negative battery. The relay 15, upon operation, interrupts the locking circuit of the relay 14 at its *a* armature and, at its *b* armature, removes positive battery from the relay 16, the induction coil 18 and the relay 23. The reproduction of the identifying message is thereby stopped, and the substation telephone receiver restored to the normal position on the hook switch. The station is thus restored to the condition which obtained at the beginning of this description.

It will be seen from the foregoing that, if the central station attendant is connected to the wrong substation, it being contemplated that a number of similar stations may be controlled from a single control station, the called station will respond, identify itself and restore to normal if appropriate signals are not transmitted to it. This feature is also of importance in the event that a telephone subscriber, other than the central station attendant, should be erroneously connected to the substation telephone. In such instances, the calling party, not having the means of controlling the called-station equipment, the latter would restore to normal after repeating its identifying message twice.

It is obvious that, if control and signalling operations are to be accomplished, the automatic restoration of the equipment must be precluded when desired. In order to prevent automatic restoration and also to control the apparatus units at the substation and obtain a signal indicating their position, I provide, at the central station, suitable means for producing sounds of predetermined frequency. These means are not illustrated since they may take any one of a number of forms. High-pitched buzzers, whistles or other suitable means may be employed, and the attendant at the central station may even be able to produce sounds of required frequency from his own throat by whistling appropriately. In the following description, it will be assumed that whistles are employed to produce the required sounds. When, after a connection with the substation has been made and it has identified itself, a sound of appropriate frequency which will be designated as tone A, is produced at the transmitter of the central station telephone, this sound will be

transmitted to the substation telephone receiver and thence to the microphone 19 and the induction coil 18.

A plurality of relays 46, 47 and 48 are connected in parallel to the induction coil 18. These relays are of the mechanically tuned, vibrating-reed type which is well known, and are designed to respond by closing their contacts only when energized by currents of predetermined frequencies. Assuming that after a telephonic connection to the substation has been obtained and before the station identifying message has been repeated the second time, a sound of the frequency corresponding to tone A to which the relay 46 responds, is produced by a whistle at the central station telephone transmitter, the relay 46 will be caused to close its contacts and connect the grid and cathode of a so-called "grid-glow" tube 49 which is also well known in the art. This device serves to prevent flow of current in the circuit in which it is connected, as long as the grid retains a predetermined potential with respect to the other electrodes. When this potential is removed, as by connecting the cathode and grid, current flows through the tube. A relay 50 of the slow-release type is connected in series with the grid-glow tube 49, and when the latter is caused to pass current by the energization of the relay 46, the relay 50 is energized.

When the relay 50 is thus energized, it completes an obvious energizing circuit for a relay 51 at its *a* armature. The relay 51 is energized and, at its *b* armature and front contact, completes a locking circuit for itself to positive battery through the back contact and *b* armature of relay 15. The relay 50, at its *b* armature, supplies negative battery to the stepping magnet 42 of the selector switch 38, which attracts its ratchet against the tension of its actuating spring to prepare to move the wipers of the selector switch 38 to their second contacts when the stepping magnet is deenergized. The relay 51, at its *a* armature, prepares a circuit for the winding of the relay 24 and this circuit is completed when the switch 34 is closed by the engagement therewith of the projection 35' after the transmission of the station-identifying message. The relay 24, upon being energized, completes a locking circuit at its *b* armature which also includes the *a* and *c* armatures of the relay 51.

At its *c* armature, the relay 24 interrupts the circuit of the relay 23 and, by deenergizing the latter, stops the film motor 28 and deenergizes the lamp 27 and the amplifier 25. At its *a* armature, the relay 24 supplies positive battery from the *b* armature and back contact of the relay 15 to the *a* armature and back contact of a relay 52, *b* armature and back contact of the relay 53, to the winding of the stepping magnet 54 of a second selector switch 55 having wipers 56, 57 and 58 and

59 and associated banks of contacts. The function of the selector switch 55 is different from that of the selector switch 38, although the mechanical construction of the two is identical. The selector switch 55 serves to transmit signals indicating the positions of the various apparatus units at the substation, while the selector switch 38 serves to select the particular apparatus unit which it is desired to operate and supervise.

The energization of stepping magnet 54 causes the ratchet of the selector switch 55 to prepare to advance the wipers thereof to the second contact and also closes an energizing circuit from the same source of positive battery traced for the stepping magnet 54, through the front contact of the stepping magnet and to the winding of a relay 60, to negative battery. The relay 60 is thereby energized to close an obvious energizing circuit for the relay 53. The relay 53, upon being energized, interrupts the circuit originally traced for the stepping magnet 54 at the *b* armature of the former, so that, the stepping magnet 54 being deenergized, the selector switch 55 advances its wipers to the second contact.

At the end of the whistle blast producing the frequency required to operate the relay 46, the relay 50 is deenergized, and the stepping magnet 42 of the selector switch 38 is also deenergized to permit the wipers of the said switch to advance to its second contacts. The selector switch 38 is now in position to control and supervise an apparatus unit, such as the circuit breaker 61. By repeating the whistle blasts of tone A, the selector switch 38 may be so stepped from contact as to be associated with any circuit breaker in the substation, corresponding to that shown in 61 or to any other apparatus unit located thereat. For the purposes of the present description, however, it will be assumed that tone A will not be repeated, so that the selector switch 38 remains in position to control and supervise the circuit breaker 61. It is unnecessary to state that, when the selector switch 38 moves to its second contact, the energizing circuits for the relays 36 and 43 are interrupted at the first contact engaged by the wiper 37.

When the wiper 56 of the selector switch 55 has engaged its second contact, a circuit is completed from positive battery, through said contact and wiper, to the back contact of the stepping magnet, the *b* armature and back contact of the relay 53 and the winding of the stepping magnet 52, to negative battery. The completion of this circuit causes the energization of the stepping magnet and the consequent energization of the relays 60 and 53, as described before, so that the selector switch 55 is again advanced, this time from its second contact to the third contact, as a result of the deenergization of the mag-

net 54 which is effected by the energization of the relay 53. The continued successive energization of the stepping magnet 54 and the relays 60 and 53 causes the wipers of the selector switch 55 to be advanced continuously.

As the wiper 58 is advanced from contact to contact, a series of buzzer impulses will be produced by a buzzer 62, located adjacent to the substation telephone transmitter. It will be noted that the second to sixth contacts of the bank associated with the wiper 58 are strapped together and connected to one terminal of the buzzer 62 through the back contact and *a* armature of the relay 53. It will be remembered that the relay 53 is deenergized after the lapse of a short time interval following the deenergization of the stepping magnet 54. In other words, the stepping magnet 54 is energized, the relay 60 is energized, the relay 53 is energized, the stepping magnet 54 is deenergized and the relays 60 and 53 are deenergized. The relay 53 is a slow-release relay, however, so that its back contacts are not closed until after the wipers of the switch 55 have advanced to succeeding contact after the magnet 54 is deenergized. The buzzer circuit may be traced in detail as follows:—from positive battery, through the *b* armature and back contact of relay 36, the back contact and *c* armature of relay 52, the wiper 58 and associated bank contacts, the back contact and *a* armature of the relay 53, to the buzzer 62 and negative battery.

The purpose of the impulses generated by the wiper 58 is to indicate the particular apparatus unit selected, that is to say, if No. 1 breaker has been selected by the selector switch 38, only a single buzzer impulse will be transmitted. If No. 2 breaker has been selected by the selector 38, two buzzer impulses will be transmitted. The central station attendant is thus assured that the desired selection has been effected. If, for example, the attendant transmits the A tone three times to select breaker No. 3, he obtains, as an answer-back signal, three buzzer impulses.

The means by which the appropriate number of buzzer signals are returned to the central station attendant will now be described. It will be observed that the contacts of the banks associated with the wipers 39 and 57 of the switches 38 and 55, respectively, are electrically connected. It is thus apparent that, if the wipers of the switch 38 are in engagement with their second bank contacts, which will permit control and supervision of No. 1 breaker, as will be described later, a circuit will be completed from positive battery to wiper 39 of switch 38, its second contact, the second contact of the bank associated with wiper 57 to the winding of relay 52 and negative battery. This circuit will be prepared as soon as the switch 38 reaches its second stepping position but will not be com-

pleted until the switch 55 reaches the corresponding position. Because of the slow-release relay 53, the stepping of the switch 55 is at a slower rate than that of the switch 38, the latter being stepped directly in response only to the sounds produced by the central station attendant.

When the relay 52 is energized by the completion of the above circuit, the original energizing circuit for the stepping magnet 54 is interrupted at the *a* armature of the relay 52. This does not affect the stepping of the switch 55 since the positive battery therefor is now obtained from the bank contacts associated with the wiper 56. The energization of the relay 52, however, at its armature *c* opens the circuit for the buzzer 62 so that, after the transmission of the first buzzer impulse, no further impulses will be transmitted as a result of the successive engagement of the wiper 58 with its third to sixth bank contacts. If a breaker, other than breaker No. 3, (not shown) is selected, of course, the interruption of the buzzer signals will occur at a different point in the cycle of the selector-switch operation, because the circuit for the relay 52 will not be completed until the wipers have advanced to the position corresponding to the selected breaker. It should be noted that the relay 52, at its armature *b*, closes its own locking circuit.

The selector switch 55 has now transmitted a signal to indicate the position of selector switch 38, and it continues its operation, without further signal transmission from the central station, until the wipers engage their seventh bank contacts. At this point, a shunting circuit is completed from negative battery, through the *c* armature and back contact of relay 36, the seventh bank contact and wiper 57, to the winding of relay 52 which is thereby shunted and deenergized. The deenergization of the relay 52, of course, re-establishes the slow stepping of the selector switch 55.

Simultaneously, the *c* armature of the relay 52 re-establishes the buzzer circuit over a path different from that traced before. This path includes the wiper 58 and its associated bank contacts and the *a* armature of one of the relays 63 and 64. The re-establishment of a buzzer circuit causes a signal to be transmitted to indicate the position of the selected circuit breaker. The signal will be two buzzer impulses, caused by the engagement of wiper 58 with its seventh and eighth contacts, if the circuit breaker 61 is closed, and four buzzer impulses resulting from engagement of wiper 58 with its ninth to twelfth contacts, if the breaker is open. The character of the signal transmitted is determined, as stated, by the position of the circuit breaker 61.

When the circuit breaker 61 is open, an associated circuit-breaker relay 65 will be

deenergized. Since the relay 65 is deenergized, a circuit is completed for the relay 64 from positive battery, through the winding of said relay, the back contact and armature *a* of the relay 65, the second bank contact and wiper 37, to negative battery. The relay 64, therefore, is energized and, at its armature *a*, extends the circuit from positive battery, through armature *b* and back contact of 36, the back contact and armature *c* of relay 52, the wiper 58 and its last four bank contacts, to the armature *a* and front contact of relay 64 and thence to the buzzer 62.

If the circuit breaker 61 is closed, the associated relay 65 will be energized and also the relay 63, since negative battery will be connected to the latter through the wiper 37, its 2nd contact, armature *a* and front contact of relay 65, armature *a* and back contact of relay 63. When the relay 63 is energized, instead of the relay 64, as described above, the buzzer circuit will be controlled by 7th and 8th contacts associated with the wiper 58, to produce two buzzer impulses indicating that the circuit breaker 61 is closed.

In this manner, the character of the signal impulse transmitted is made to depend on the position of the circuit breaker so that the attendant at the central station, in addition to checking the selection, by the answer back described above, is also able to determine the position of the selected unit by means of the buzzer code.

The central station attendant has now obtained an indication of the position of the selector switch 38, as well as an indication of the position of the apparatus unit or circuit breaker corresponding to such position of the selector switch. It will be desirable, obviously, to enable him to effect any desired operation of the sub-station circuit breaker, and I provide means for accomplishing this result.

If the attendant desires to close the circuit breaker 61, he operates any convenient means, as mentioned above, for producing a sound at the central station 10 having a frequency to which the relay 47 responds which, for brevity, may be designated tone B. The consequent operation of the relay 47 causes a grid-glow tube 66 to energize a relay 67 in the manner described for grid-glow tube 49 and relay 50.

The operation of relay 67 connects positive battery through the front contact *a* armature thereof to the upper terminal of the winding of relay 68. Positive battery is also supplied from the same source through the front contact and *b* armature of relay 64, which, as explained above, is energized when the circuit breaker 61 is open, to the lower terminal of a winding of the relay 69. Negative battery is supplied through the front contact and the *b* armature of relay 67 to the upper terminal of the winding of relay 69. The

relay 69 is thus energized and locks in momentarily through its *b* armature, until relay 67 is deenergized as a result of the cessation of tone B.

Positive battery is also supplied, through the front contact and *a* armature of the relay 67 to the front contact and *b* armature of the relay 64, to the back contact and *b* armature of relay 68, and *c* armature and back contact of relay 63, to the wiper 40 of the selector switch 38 and the second contact of the bank associated therewith, to the winding of relay 65. The relay 65 is thereby energized to close its own locking circuit at its *b* armature. The operation of the *c* armature of relay 65 transfers positive battery from the circuit-breaker tripping relay 70 to the circuit-breaker closing relay 71. The relay 71, upon operation, completes an obvious energizing circuit for the closing coil of the circuit breaker 61 which is thereby closed.

At its *a* armature, the relay 65 transfers negative battery, to which it is connected by wiper 37 and its second contact, from the relay 64 to the relay 63, the circuit for the latter including the *a* armature and back contact of the relay 69 which is deenergized as soon as the attendant ceases to produce tone B which is necessary to operate the relay 67. The relay 63, upon energization, causes the circuit for the buzzer 62 to be transferred from the group of four contacts of the bank cooperating with wiper 58 to the associated group of two contacts, so that two buzzer impulses are transmitted over the telephone circuit, indicating to the attendant that the circuit breaker 61 has closed. The selector switch 55 operates continuously and thus transmits the signal indication repeatedly.

Now that the circuit breaker has been closed, let it be assumed that the central-station attendant desires to trip the breaker. For this purpose, it will also be assumed that the selector switch 38 is in position to control circuit breaker 61, that is, its wipers engage their second bank contacts. Since the circuit breaker 61 was assumed to be closed, the relay 65 is, of course, energized and locked in. The relay 63 is also energized by the completion of a circuit already traced.

The tripping operation is effected by the same impulse as that required for the closing operation, namely, an impulse of tone B. When this impulse is produced by the central-station attendant, the relay 47 operates to discharge the tube 66 and energize the relay 67. The operation of the relay 67 at its armature *a*, as already described, supplies positive battery to the upper terminal of the winding of relay 68. At its *b* armature, the relay 67 connects negative battery to the upper terminal of the relay 69 and also through the front contact and *b* armature of the relay 63, to the lower terminal of the relay 68. The relay 69 is not energized, how-



ever, since its circuit is open at the armature *b* of the relay 64. The relay 68, having positive and negative battery connected to its terminals, is energized and locks in temporarily through its armature *a* and its front contact, until the tone B ceases.

The negative battery supplied to the lower terminal of the winding of relay 68, is also supplied through the back contact and *c* armature of the relay 69, the back contact and *c* armature of the relay 64 to wiper 41 of the selector switch 38 and its second contact, which is connected to the lower terminal of the winding of the circuit-breaker relay 65. Since negative battery is now connected to both terminals of the winding of relay 65, the relay is deenergized and, at its *c* armature and back contact, completes a circuit for the circuit-breaker-closing relay 70, which, in turn, closes a circuit to the circuit-breaker trip coil.

The operation of the circuit breaker, in the manner heretofore described, causes the signal transmitted to the central station to be changed in accordance with the circuit-breaker position.

Additional circuit breakers may be similarly controlled by relays similar to 65, such as that shown at 78. Signal lamps 79 and 80 may be provided at the sub-station for indicating thereat the position of the various circuit breakers if the latter are located outdoors, to give an indication of their position within the station.

It will be obvious that the lamps 79 are energized when their circuit-breaker closing relays are energized, and that the lamps 80 will be illuminated when their circuit-breaker closing relays are deenergized.

I provide also means whereby the attendant at the central station may restore all of the equipment at the substation to its normal condition. To effect this result, the attendant produces a designated tone C, of a frequency to which the relay 48 responds, thus causing the operation of the grid-glow tube 72 and a relay 73 connected in series therewith. The operation of relay 73, at its *a* armature, connects negative battery to the *a* armature and back contact of relay 43, to the armature and back contact of the stepping magnet 42, to the winding of the stepping magnet, the other end of which is connected to positive battery. The selector switch 38 thereby operates step by step, breaking its own energizing circuit and is thus restored to normal in a very short time. When the selector switch 38 reaches the normal position, the wiper 37 connects the upper terminal of the winding of the relay 43 to negative battery, and the relay is energized, the other terminal thereof being connected to positive battery. The relay 36 is energized in the same manner.

The energization of the relay 43, at its *a*

armature, interrupts the "spinning" or fast-stepping circuit for the selector switch and the latter is thereby stopped. When the relay 36 is energized, it supplies positive battery through its *b* armature and front contact to the wiper 59 of the selector switch 55. Since the selector switch 55 continues stepping, a circuit will be completed for the buzzer 62 through the wiper 59 as it engages its first, third and fifth contacts. In this way, a particular buzzer code is transmitted to the central-station attendant to inform him that the apparatus at the substation is restoring itself to normal. When the wiper 59 reaches its sixth contact, it supplies positive battery to the sixth contact of the bank cooperating with wiper 57. This causes the energization of relay 52 which energizes, and at its *a* armature opens the normal or slow-stepping circuit of the stepping magnet 54 of the selector switch 55. A spinning circuit for the selector switch 55 is thereby established through the wiper 56, of the selector switch, 55 returns to its normal position in a very short space of time.

When the wipers engage the last contact, a circuit is established from negative battery through the *c* armature and front contact of relay 36, the last contact of the bank engaged by wiper 57, through said wiper to the winding of relay 52. Negative battery is now connected to both terminals of the winding of relay 52 and the latter is thereby deenergized. The deenergization of the relay 52 reestablishes the slow-stepping circuit for the selector switch 55 and the buzzer code indicating that normal condition is again transmitted to the central station attendant by the engagement of wiper 59 with its first, third and fifth contacts.

In order to cause the substation telephone to hang up and other equipment return to the idle position, after a repetition of the "restored-to-normal" signal, the attendant again energizes the relay 48 by repeating tone C. The relay 43, which was energized when the selector switch 38 was restored to normal, closed a circuit at its *a* armature. A circuit is now completed from negative battery to the front contact and *a* armature of the relay 73 which responds to tone C and is a slow-release relay, to the *a* armature and front contact of relay 43 which was energized as wiper 37 engaged its 1st contact, to the *a* armature and back contact of a relay 74, to the winding of a relay 75 and positive battery. The relay 75, at its *a*-armature, prepares a series energizing circuit for the relays 74 and 75 which, however, does not become effective until the relay 73 releases its armature as tone C ceases. When this has occurred, a series circuit is completed from positive battery through the windings of relays 75 and 74, the *a* armature and front contact of relay 75, the front contact and *b* armature of relay

43 to the back contact and *c* armature of the relay 15, to negative battery. Upon the second impulse of tone C, the relay 73 is again energized and supplies positive battery through its front contact and *b* armature, the front contact and *b* armature of relay 74, to the relay 15. As the relay 15 operates, the locking circuit of the relay 14 is opened and it is deenergized to restore all equipment to normal.

It is also desirable, in systems of this kind, to provide means for automatically indicating to the central-station attendant when a circuit breaker at the substation operates automatically. All the substation circuit breakers will be provided with the usual automatic tripping devices and may also be provided with automatic closing equipment, and the sequence of operations resulting from an automatic tripping or closing of a circuit breaker will now be described.

If it is assumed that the circuit breaker 61 is automatically tripped after having been closed, the normally closed energizing circuit of a relay 76 will be interrupted at the auxiliary switch 77 of the circuit breaker 61. The circuit of the relay 76 is restored immediately but the momentary interruption therein permits the relays 76 and 33 to energize in series, the circuit including windings of said relays, the front contact and *a* armature of relay 76 to the first contact of the bank associated with the wiper 39, through said wiper to positive battery. The energization of relay 33 transfers positive battery from the circuit for the lamp 27 to the circuit for the lamp 26. At the same time, the relay 33, at its *b* armature, energizes relay 14 to place the speech reproducer in operation and to lift the receiver of the substation telephone.

The speech record produced by the energization of the lamp 26 sends out a call for the telephone at the central station. This call is received by the telephone operator and completed in the usual manner. When the central-station attendant has obtained a connection with the substation, he may make appropriate selections to determine which circuit breaker has been actuated and take such action as may appear advisable under the circumstances. The restoration of the system is accomplished in the same manner as described heretofore. The relays 76 and 33 will, obviously, be deenergized as soon as the selector switch 38 steps from its initial position and the energizing circuit of the relay 76 will be reestablished to prepare for the repetition of the sequence described above.

From the foregoing description, it is apparent that, in the system of my invention, I have provided a means for permitting an attendant at the central station of a power-distribution system, to control circuit breakers at distant substations and observe the operation thereof, making use of telephone circuits

for transmitting the control and signalling impulses. It is a particular feature of my invention that the control and signalling impulses are such as are normally transmitted over telephone circuits and hence are not objectionable, in any way, from the standpoint of interference with normal use of said circuits.

In addition, I have provided means for obtaining a vocal response from an unattended substation when called by a central-station attendant. I have also provided means for causing the central station telephone to be automatically called by the performance of the usual steps in putting through an ordinary telephone call, substituting an electro-mechanical speech reproducer for the calling party in an ordinary operation. The advantages and desirable features of the system of my invention, it is believed, will be obvious from the description thereof without further discussion.

Since numerous alterations and modifications of the embodiment of my invention herein illustrated and described will doubtless occur to those skilled in the art, it is not my intention to be limited to the embodiment herein shown, except as necessitated by the scope of the appended claims.

I claim as my invention:

1. A remote-control system adapted to be operated by sounds of different frequencies over standard telephone circuits including a control office, a remote station, telephone connections therebetween, speech-reproduction means at said station, a receiver-lifting device for the remote station telephone, means responsive to the ringing current for the station telephone bell for energizing the receiver lifting device and initiating the operation of said speech reproduction means to transmit a predetermined vocal message to said office to identify the station, automatically operable apparatus units at said station and means responsive to the operation of one of said units for energizing the receiver lifting device and initiating the operation of said speech-reproduction means to transmit to a telephone operator a call for the central-station telephone.

2. A remote-control system adapted to be operated by sounds of different frequencies transmitted over telephone circuits, including a control office, a remote station and telephone connections therebetween, speech-reproducing means at said station, said means comprising a motor-actuated film record, means responsive to the ringing current for the station telephone bell for lifting the telephone receiver and initiating the operation of said speech-reproducing means to transmit speech to said office to identify said station, and means actuated by a predetermined movement of the film record to effect the release of the receiver and stop the speech-reproducer

by deenergizing the actuating motor for the film record.

3. In a remote-control system responsive to sounds of differing frequencies, a control office, a remote station having automatically operable apparatus units therein, telephone connections between said stations, speech-reproducing means at said station selectively operable to identify the station when called and for calling the number of the office telephone, means responsive to the ringing of the station telephone bell for lifting the receiver and for effecting the operation of said speech reproducing means to identify the station and means responsive to an automatic operation of one of said units for lifting the receiver and effecting the operation of the speech reproducing means to call the number of the office telephone.

4. In a remote-control system, a control office, a remote station having automatically-operable apparatus units therein, telephones in said office and station connected to a common system, an electro-magnetic receiver-lifting device for the telephone at the remote station, a speech-reproducing device operable to produce different vocal messages near the transmitter of the telephone at the remote station, said device comprising a movable film record, a motor for actuating the film record and a plurality of control lamps effective when separately energized to select the vocal message produced by the speech-reproducing device, and a relay responsive to the automatic operation of an apparatus unit for effecting the energization of the receiver-lifting device and the actuating motor for the film record and for selecting a predetermined control lamp.

5. A remote-control system comprising a dispatcher's office and a substation, telephones at said office and station disposed to be connected through a public telephone system, speech-reproducing means at the substation selectively operable to produce vocal sounds of predetermined nature, means responsive to a calling operation for the substation telephone for rendering said telephone operative and for initiating the operation of the speech-reproducing means to cause said means to identify the substation, a plurality of apparatus units at the substation, and means responsive to the automatic operation of any one of said apparatus units for rendering the substation telephone effective to transmit a message to the telephone operator and for initiating the operation of the speech-reproducing means to cause said speech-reproducing means to produce vocal sounds calling for a connection to the telephone at the dispatcher's office.

6. In a remote-control system comprising a dispatcher's office and a remote station, telephones at each of said stations disposed to be connected through a public telephone system,

a plurality of apparatus units at the substation each being disposed to be operated to a plurality of positions, a speech reproducer associated with the substation telephone operable to transmit vocal messages of different predetermined meanings, and means operable in response to the automatic operation of an apparatus unit for rendering the substation telephone operable to transmit a call and to cause the speech reproducer to transmit a predetermined message to the telephone operator calling for the dispatcher's office.

7. In a remote-control system comprising a dispatcher's office and a substation, telephones in said office and substation disposed to be connected through a public telephone system, apparatus units at the substation, electro-magnetically operated means for lifting the receiver of the substation telephone, a speech-reproducing device operable to produce different predetermined vocal messages near the transmitter of the substation telephone, means responsive to the ringing of the substation telephone for effecting the operation of the receiver-lifting means and for initiating the operation of the speech-reproducing device to transmit a vocal message to identify the station, means responsive to sounds of predetermined frequency for selecting any one of the apparatus units, and means responsive to predetermined operations of the speech-reproducing device for effecting a disconnection of the substation telephone in the event a selecting operation has not been made before the said predetermined operations of the speech-reproducing device are completed.

8. In a remote-control system comprising a dispatcher's office and a substation, telephones in said office and substation disposed to be connected through a public telephone system, apparatus units at the substation, electro-magnetically operated means for lifting the receiver of the substation telephone, a speech-reproducing device operable to produce different predetermined vocal messages near the transmitter of the substation telephone, means responsive to the ringing of the substation telephone for effecting the operation of the receiver-lifting means and for initiating the operation of the speech-reproducing device to transmit a vocal message to identify the station, means responsive to sounds of predetermined frequency for selecting any one of the apparatus units, a control switch disposed to be actuated by the speech-reproducing device upon the completion of each vocal message, means responsive to a predetermined number of operations of said control switch for causing the receiver-lifting means to restore the receiver to normal position and to discontinue the operation of the speech-reproducing device, and means actuated in response to a selecting operation for rendering the control switch ineffective to

restore the receiver of the substation telephone to its normal position.

9. A remote-control system comprising a dispatcher's office and a substation, telephones at said dispatcher's office and substation, a plurality of apparatus units at the substation, an electro-magnetic receiver lifting device for the substation telephone, a speech-reproducing device for producing vocal sounds of predetermined character near the transmitter of the substation telephone, means responsive to the ringing current for the substation telephone for effecting the energization of the receiver lifting device and for causing the speech-reproducing device to transmit a predetermined vocal message to identify the substation, a selector for selecting any one of the apparatus units, means responsive to sounds of a predetermined frequency for effecting the operation of the selector to effect the selection of any desired apparatus units, control means operable to discontinue the operation of the speech-reproducing device, and means responsive to the operation of the sound-responsive device for actuating the selector and a predetermined operation of the sound-reproducing device for effecting the operation of the control means, thereby to render the sound-reproducing device inoperative in response to the initiation of a selecting operation.

In testimony whereof, I have hereunto subscribed my name this 16th day of March, 1929.

ROY J. WENSLEY.

35

40

45

50

55

60

65