

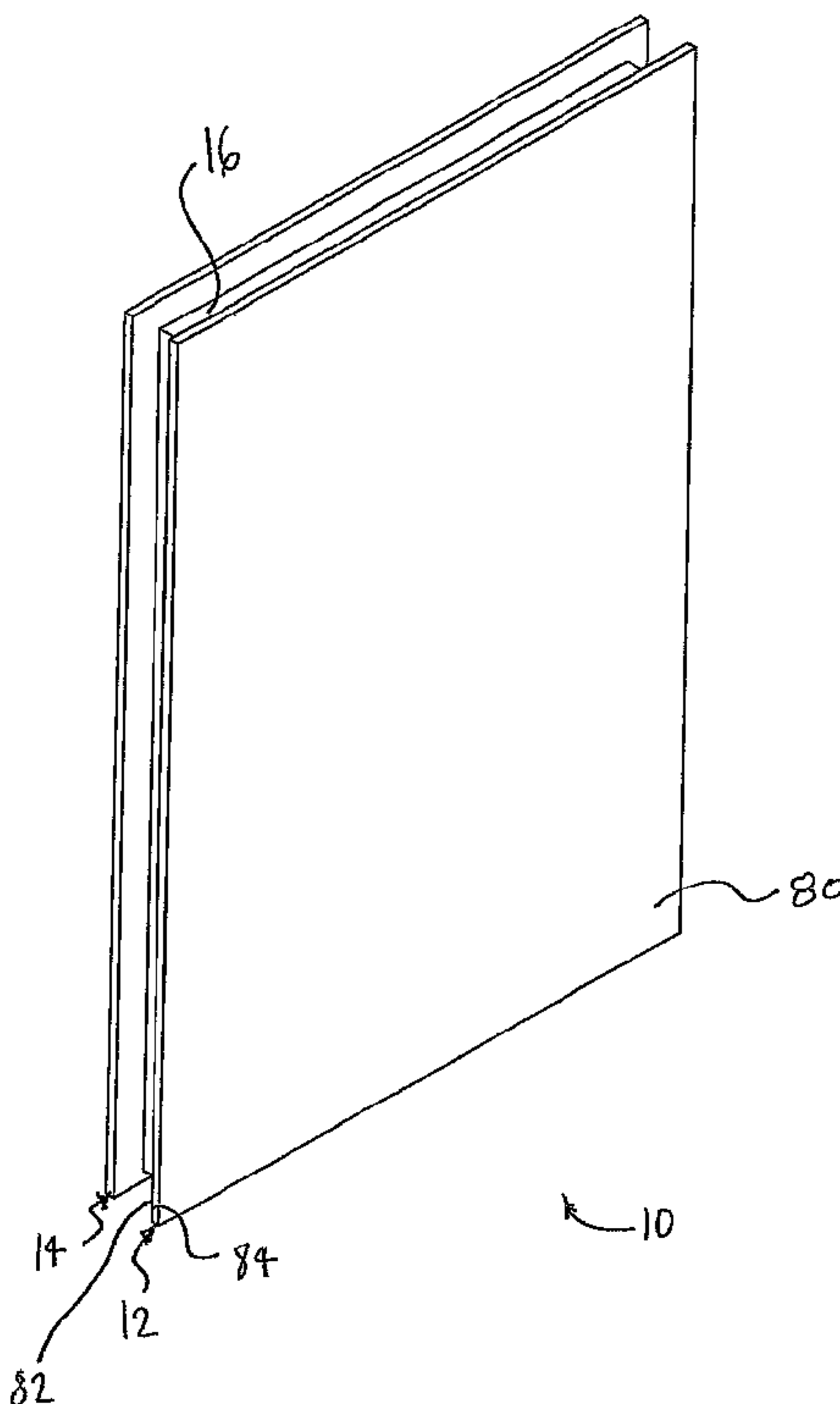

(86) Date de dépôt PCT/PCT Filing Date: 2005/10/04
 (87) Date publication PCT/PCT Publication Date: 2006/04/20
 (85) Entrée phase nationale/National Entry: 2007/03/30
 (86) N° demande PCT/PCT Application No.: US 2005/035836
 (87) N° publication PCT/PCT Publication No.: 2006/041924
 (30) Priorité/Priority: 2004/10/04 (US60/615,711)

(51) Cl.Int./Int.Cl. *C03C 17/38* (2006.01),
B32B 17/10 (2006.01), *B65D 85/48* (2006.01),
B65G 49/06 (2006.01), *C03C 17/42* (2006.01)
 (71) Demandeur/Applicant:
 CARDINAL CG COMPANY, US
 (72) Inventeurs/Inventors:
 KRISKO, ANNETTE, US;
 GROMMESH, ROBERT, US
 (74) Agent: BORDEN LADNER GERVAIS LLP

(54) Titre : REVETEMENT EN COUCHE MINCE ET TECHNOLOGIE DE PROTECTION TEMPORAIRE, UNITES DE VITRAGE ISOLANT ET PROCEDES ASSOCIES
 (54) Title: THIN FILM COATING AND TEMPORARY PROTECTION TECHNOLOGY, INSULATING GLAZING UNITS, AND ASSOCIATED METHODS



(57) **Abrégé/Abstract:**

The present invention in some embodiments provides sputter deposition techniques for applying thin film and thereafter applying over the sputtered film a temporary protective film. The thin film can optionally be applied by sputtering a target in a gaseous sputtering atmosphere containing an oxidizing gas and/or an inert gas. The invention in some embodiments relates to an insulating glazing unit or a monolithic pane having a thin film coating, deposited for example by sputtering, on at least one major surface, the thin film coating carrying a temporary protective film. The invention also provides embodiments involving high efficiency methods for producing such products.

(12) INTERNATIONAL APPLICATION PUBLISHED UNDER THE PATENT COOPERATION TREATY (PCT)

(19) World Intellectual Property Organization
International Bureau(43) International Publication Date
20 April 2006 (20.04.2006)

PCT

(10) International Publication Number
WO 2006/041924 A3

(51) International Patent Classification:

C03C 17/38 (2006.01) **B65D 85/48** (2006.01)
C03C 17/42 (2006.01) **B65G 49/06** (2006.01)
B32B 17/10 (2006.01)

(21) International Application Number:

PCT/US2005/035836

(22) International Filing Date: 4 October 2005 (04.10.2005)

(25) Filing Language: English

(26) Publication Language: English

(30) Priority Data:

60/615,711 4 October 2004 (04.10.2004) US

(71) Applicant (for all designated States except US): **CARDINAL CG COMPANY** [US/US]; 775 Prairie Center Drive, Suite 200, Eden Prairie, MN 55344-4235 (US).

(72) Inventors; and

(75) Inventors/Applicants (for US only): **KRISKO, Annette** [US/US]; E-10248 State Road 60, Sauk City, WI 53583 (US). **GROMMESH, Robert** [US/US]; 6912 Minnetonka Boulevard, St. Louis Park, MN 55426 (US).(74) Agents: **SNUSTAD, Eric, J.** et al.; Fredrikson & Byron, P.A., Suite 4000, 200 South Sixth Street, Minneapolis, MN 55402-1425 (US).

(81) Designated States (unless otherwise indicated, for every kind of national protection available): AE, AG, AL, AM, AT, AU, AZ, BA, BB, BG, BR, BW, BY, BZ, CA, CH, CN, CO, CR, CU, CZ, DE, DK, DM, DZ, EC, EE, EG, ES, FI, GB, GD, GE, GH, GM, HR, HU, ID, IL, IN, IS, JP, KE, KG, KM, KP, KR, KZ, LC, LK, LR, LS, LT, LU, LV, LY, MA, MD, MG, MK, MN, MW, MX, MZ, NA, NG, NI, NO, NZ, OM, PG, PH, PL, PT, RO, RU, SC, SD, SE, SG, SK, SL, SM, SY, TJ, TM, TN, TR, TT, TZ, UA, UG, US, UZ, VC, VN, YU, ZA, ZM, ZW.

(84) Designated States (unless otherwise indicated, for every kind of regional protection available): ARIPO (BW, GH, GM, KE, LS, MW, MZ, NA, SD, SL, SZ, TZ, UG, ZM, ZW), Eurasian (AM, AZ, BY, KG, KZ, MD, RU, TJ, TM), European (AT, BE, BG, CH, CY, CZ, DE, DK, EE, ES, FI, FR, GB, GR, HU, IE, IS, IT, LT, LU, LV, MC, NL, PL, PT, RO, SE, SI, SK, TR), OAPI (BF, BJ, CF, CG, CI, CM, GA, GN, GQ, GW, ML, MR, NE, SN, TD, TG).

[Continued on next page]

(54) Title: THIN FILM COATING AND TEMPORARY PROTECTION TECHNOLOGY, INSULATING GLAZING UNITS, AND ASSOCIATED METHODS

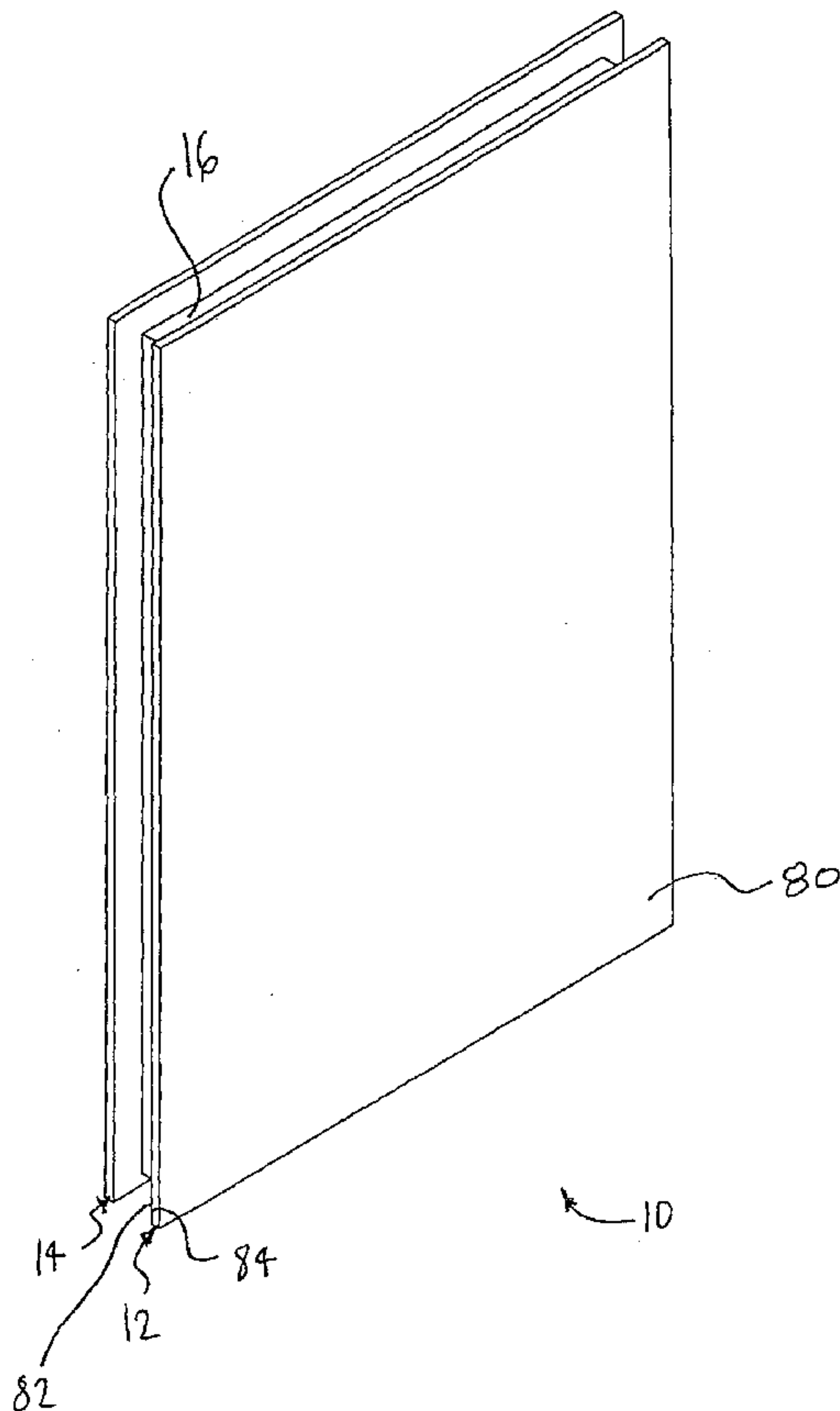

(57) Abstract: The present invention in some embodiments provides sputter deposition techniques for applying thin film and thereafter applying over the sputtered film a temporary protective film. The thin film can optionally be applied by sputtering a target in a gaseous sputtering atmosphere containing an oxidizing gas and/or an inert gas. The invention in some embodiments relates to an insulating glazing unit or a monolithic pane having a thin film coating, deposited for example by sputtering, on at least one major surface, the thin film coating carrying a temporary protective film. The invention also provides embodiments involving high efficiency methods for producing such products.

WO 2006/041924 A3

WO 2006/041924 A3



Published:

— *with international search report*

(88) Date of publication of the international search report:

19 October 2006

For two-letter codes and other abbreviations, refer to the "Guidance Notes on Codes and Abbreviations" appearing at the beginning of each regular issue of the PCT Gazette.

**THIN FILM COATING AND TEMPORARY PROTECTION
TECHNOLOGY, INSULATING GLAZING UNITS,
AND ASSOCIATED METHODS**

Field of the Invention

5 The present invention relates in some embodiments to sputter deposition techniques for applying thin film and thereafter applying over the sputtered film a temporary protective film. The thin film can be applied by sputtering a target in a gaseous sputtering atmosphere containing an oxidizing gas and/or an inert gas. The invention in some embodiments relates to an insulating glazing unit or a monolithic pane having a thin
10 film coating, deposited for example by sputtering, on at least one major surface, the thin film coating carrying a temporary protective film. The invention also provides embodiments involving high efficiency methods for producing such products.

Background of the Invention

15 In the coated glass industry, it is common to apply one or more thin films onto glass to impart desired properties in the coated glass. For example, in manufacturing glass for window and door applications, it is advantageous to apply infrared-reflective coatings as well as one or more other coatings that provide photoactivity.

 Insofar as infrared-reflective coatings are concerned, these coatings help provide
20 comfortable interior climates within homes and other buildings. Human beings have a relatively narrow temperature range in which they are comfortable. Unfortunately, infrared (IR) energy from the sun entering a room through a window can quickly raise the temperature in the room to an uncomfortable level. Infrared-reflective coatings have been developed, inter alia, to prevent heat spikes in a room by reflecting some of the incident
25 infrared energy. These coatings also help keep a room warm in the winter by reflecting back into the room some of the infrared energy that would otherwise escape through windows. Thus, infrared-reflective coatings help establish a comfortable living environment while reducing heating and air conditioning costs.

 Insofar as photocatalytic coatings are concerned, these coatings have been
30 developed to provide low-maintenance properties for windows and other glazings. Some photocatalytic coatings can reduce the need for, or the effort involved in, cleaning the glass of windows, doors, skylights, and the like. Given the time and effort spent by the average homeowner on window cleaning, the advantages of a low-maintenance window are apparent. Moreover, when one considers the extensive measures and expense involved

in cleaning the glass exteriors of modern skyscrapers, the upside of low-maintenance glass can be acutely appreciated.

Photocatalytic coatings can be designed to have a self-cleaning effect. For example, thick photocatalytic coatings tend to have a significant ability to chemically
5 degrade organic contaminants. Such coatings commonly comprise a relatively thick layer of titanium dioxide. Thick titanium dioxide, unfortunately, produces relatively high levels of visible reflectance. It has been discovered that this high visible reflection actually exaggerates the appearance of dirt on a window, resulting in a window that looks particularly dirty. This, of course, is not desirable, as the very purpose of a photocatalytic
10 coating is to provide a cleaner window. Furthermore, thick titanium dioxide films tend to produce more reflected color than is commonly desired. Moreover, when a substrate is provided with both a photocatalytic coating and a low-emissivity coating, the reflected color tends to be less than ideal.

Photocatalytic coatings are commonly intended to be exposed to outdoor
15 environments. For example, on multiple-pane IG units provided with photocatalytic coating, the photocatalytic coating will commonly be provided on the #1 surface of the IG unit. Thus, when such IG units are installed in the wall of a building, the photocatalytic coating will tend to be exposed to a variety of contamination sources (painters finishing nearby areas of the building, etc.). While photocatalytic coatings may have some ability to
20 remove such contaminants by virtue of photoactivity, excessive contamination and/or inorganic contamination may not be removed completely or quickly enough by the self-cleaning action of the coating. Therefore, it would be desirable to provide such photocatalytic coatings with temporary masking protection.

Given the activity of photocatalytic coatings, it would be desirable to provide
25 masked photocatalytic products in which the masking and the coating complement each other. The properties and characteristics of the photocatalytic coating should not adversely impact the intended performance of the overlying masking. For example, direct contact between the photocatalytic coating and the masking should not unacceptably degrade any adhesive securing the masking to the coated surface. In most cases, it will be
30 unacceptable for the activity of the photocatalytic coating to degrade such adhesive to the point where the masking actually falls, or sags, off the coated surface. Moreover, the activity of the coating should not alter the character of the masking adhesive in such a way

that the adhesive and/or the masking film is rendered unacceptably difficult to remove from the coated surface. Similarly, the properties and characteristics of the masking should not adversely impact the intended performance of the photocatalytic coating. For instance, unacceptable adhesive transfer should not remain on the photocatalytic coating after the masking is removed. Moreover, the manner of applying and removing the masking should not score or otherwise permanently damage the photocatalytic coating.

The present invention provides masked photocatalytic glazing assemblies, and related methods (e.g., of manufacture and use), in which a photoactive coating and an overlying masking pay complements to each other.

10

Summary of the Invention

In certain embodiments, the invention provides monolithic panes or insulating glazing units. Preferably, the monolithic pane or insulating glazing unit includes a photocatalytic coating that provides a self-cleaning and/or hydrophilic action. Here, the pane or IG unit has an exterior surface (e.g., an outboard surface, such as the #1 surface of an IG unit) bearing a photocatalytic coating. The photocatalytic coating preferably comprises a photocatalytic material, such as titanium oxide (e.g., TiO₂). The photocatalytic coating carries a masking comprising a removable (e.g., peelable) masking film, which in preferred embodiments is a flexible, self-supporting film (e.g., comprising plastic or the like). In some embodiments, the glazing is an IG unit having both sides (e.g., the #1 and #4 surfaces) covered with masking. In certain embodiments, the photocatalytic coating has a photoactivity and/or thickness within certain ranges and/or the masking over the photocatalytic coating comprises a masking adhesive that is UV stabilized.

In certain embodiments, the invention provides a method of processing substrates. The method comprises providing a first sheet of glass, the first glass sheet having opposed first and second major surfaces. In the present embodiments, the first glass sheet is conveyed through a single sputter coater (or through multiple coaters sharing one continuous path of substrate travel), and coatings are deposited onto both the first and second major surfaces in a single pass of the first glass sheet through the sputter coater (and/or along the single path of substrate travel). Here, the sputter depositing involves applying a photocatalytic coating to the first major surface of the first glass sheet by sputtering upwardly from a first sequence of targets. This sequence of targets includes one

or more targets comprising a sputterable target material selected from the group consisting of a pure or substantially pure titanium material, a titanium alloy material, a titanium oxide material, and a compound including titanium and silicon. The sputter depositing also involves applying a low-emissivity coating to the second major surface of the first glass sheet by sputtering downwardly from a second sequence of targets. This sequence of targets includes one or more targets comprising a sputterable target material selected from the group consisting of a pure or substantially pure silver material and a silver alloy material. In the present embodiments, the thus coated first glass sheet is delivered to (and/or is positioned on) a multiple-pane insulating glass unit assembly line, the thus coated first glass sheet is conveyed along the assembly line, and the first glass sheet is assembled together with a second glass sheet, such that the resulting insulating glass assembly bounds a gap between the first and second glass sheets and the coated first major surface of the first glass sheet is an exterior surface oriented away from the gap. The present method comprises applying a peelable first masking over the photocatalytic coating. Here, the first masking comprises a masking substrate and a masking adhesive, and the application of the first masking over the photocatalytic coating involves adhering the masking adhesive directly to the photocatalytic coating. Preferably, the masking is applied by operating a first masking station, which desirably is part of the assembly line. In some cases, the method includes applying a peelable second masking over a #4 surface of the resulting insulating glass assembly, such application optionally being performed by operating a second masking station that is also part of the assembly line.

In certain embodiments, the invention provides an apparatus comprising an insulating glazing unit comprising two spaced-apart panes having a gap between them. In the present embodiments, there is a photocatalytic thin film coating on a desired major surface of one of the panes. This desired major surface is an exterior surface facing away from the gap. Further, a removable protective masking overlays the photocatalytic thin film coating. This masking comprises a masking substrate and a masking adhesive, and the masking adhesive is in direct adhesive contact with the photocatalytic thin film coating.

In certain embodiments, the invention provides an apparatus comprising an insulating glazing unit comprising two spaced-apart panes having a gap between them. In the present embodiments, there is a photocatalytic thin film coating on a desired major

surface of one of the panes. This desired major surface is an exterior surface facing away from the gap. A removable protective masking overlays the photocatalytic thin film coating. This masking comprises a masking substrate and a masking adhesive, and the masking adhesive is in direct adhesive contact with the photocatalytic thin film coating. In the present embodiments, the removable protective masking is a peelable masking, and the masking adhesive has a higher level of adhesion to the masking substrate than to the coated major surface (and thus is adapted to adhere preferentially to the masking substrate when the masking is peeled off the coated major surface), such that when the masking is peeled off the coated major surface the adhesive adheres preferentially to the masking substrate.

Description of the Drawings

Figure 1 is a perspective view of an insulating glass unit in accordance with an exemplary embodiment of the present invention.

Figure 2 is a cross-sectional view of an insulating glass unit in accordance with an exemplary embodiment of the present invention.

Figure 3 is a cross-sectional view of an insulating glass unit in accordance with an additional exemplary embodiment of the present invention.

Figure 4 is a perspective view of an assembly in accordance with an additional exemplary embodiment of the present invention.

Figure 5 is an isometric view of a workstation that can be used to apply masking to a monolithic pane or an insulating glass unit.

Figure 6 is an isometric view showing a production process (e.g., performed on a production line) for applying protective coverings to both sides of a monolithic pane or an insulating glass unit.

Figure 7 is a diagrammatic top view of an assembly comprising an insulating glass unit and a first sash piece.

Figure 8 is a diagrammatic top view of an assembly comprising an insulating glass unit and a first sash piece.

Figure 9 is a perspective view of an assembly in accordance with an exemplary embodiment of the present invention.

Figure 10 is a cross sectional view illustrating an assembly in accordance with an additional exemplary embodiment of the present invention.

Figure 11 is a flow chart exemplifying a production process in accordance with an exemplary embodiment of the invention.

5 Figure 12 is a schematic side view of a coater used in a production process of certain embodiments of the invention.

Detailed Description

The following detailed description should be read with reference to the drawings, in which like elements in different drawings are numbered identically. The drawings, 10 which are not necessarily to scale, depict selected embodiments and are not intended to limit the scope of the invention. Examples of constructions, materials, dimensions, and manufacturing processes are provided for selected elements. All other elements employ that which is known to those of skill in the field of the invention. Those skilled in the art will recognize that many of the examples provided have suitable alternatives that can be 15 utilized.

Figure 1 is a perspective view of an insulating glazing unit 10 in accordance with an exemplary embodiment of the present invention. Insulating glazing unit 10 comprises a first pane 12 having a first face 80, a second face 82, and a periphery 84 extending between first face 80 and second face 82. In the embodiment of figure 1, insulating glazing 20 unit 10 also comprises a second pane 14 having a first face and a second face. In figure 1, it can be appreciated that a spacer 16 is interposed between the second face 82 of first pane 12 and the first face of second pane 14. The spacer can be part of a sash/frame, or it can be a conventional discrete spacer.

Figure 2 is a cross-sectional view of an insulating glazing unit 10 in accordance 25 with an exemplary embodiment of the present invention. Insulating glazing unit 10 comprises a first pane 12, a second pane 14, and a spacer 16 interposed between first pane 12 and second pane 14. The spacer 16 in some embodiments can be an integral part of a sash, frame, etc. Insulating glazing unit has a #1 surface 20, a #2 surface 22, a #3 surface 24 and a #4 surface 26. With reference to figure 2, it will be appreciated that first pane 12 30 comprises #1 surface 20 and #2 surface 22. In the embodiment of figure 2, a first coating 18 is disposed on #1 surface 20 of first pane 12. Also in the embodiment of figure 2, a second coating 28 is disposed on #2 surface of first pane 12. Second pane 14 of insulating

glazing unit 10 comprises #3 surface 24 and #4 surface 26. In the embodiment of figure 2, a third coating 34 is disposed on the #4 surface 26.

In other embodiments, which are particularly preferred, the #1 and #2 surfaces of a double-pane IG unit each bear coatings 18, 28, while the #3 and #4 surfaces are uncoated. Preferably, in these particular embodiments, the coating 18 on the #1 surface carries (e.g., is covered by) a first masking 30. Additionally or alternatively, the uncoated #4 surface 26 can carry a masking 32. When provided, one or both maskings 30, 32 preferably can be removed by peeling. Further, one or both maskings 30, 32 can optionally comprise a plurality of overlapped masking strips, the overlapped strips optionally being adhesively connected to the pane (and to each other by virtue of adhesive connecting their overlapping portions).

In still other embodiments, the #1 surface of a double-pane IG unit bears a coating 18, while the #2, #3, and #4 surfaces are uncoated. Preferably, in these embodiments, the coating 18 on the #1 surface carries a first masking 30. Additionally or alternatively, the uncoated #4 surface 26 can carry a masking 32. The #2 surface in the present embodiments can optionally bear a coating. When provided, one or both maskings 30, 32 preferably can be removed by peeling. Further, one or each masking 30, 32 can comprise a plurality of overlapped masking strips, optionally arranged as depicted in figures 4 and 6.

Preferably, the coating 18 is a photocatalytic coating, such as any one of those described below. Alternatively, the first coating 18 can be another type of coating, whether currently known or subsequently developed, that has a self-cleaning function (i.e., any coating having a mechanism and/or properties that cause the coated pane surface to be at least somewhat cleaned even before any manual wiping). In an alternate embodiment, the coating 18 is a non-photoactive coating that is hydrophilic (optionally a coating comprising silica).

In embodiments wherein the #4 surface of the IG unit is coated, this coating can be a photocatalytic coating or a non-photocatalytic hydrophilic coating, such as a water-sheeting silica coating. Exemplary water-sheeting silica coatings (as well as useful deposition equipment and methods) are described in U.S. patent application 09/868,542, the entire teachings of which are incorporated herein by reference.

In the embodiment of figure 2, the #2 surface can alternatively be uncoated and the #3 surface can be coated. Alternatively, the embodiment of figure 2 can be modified so that both the #2 and #3 surfaces are uncoated. As a further alternative, both the #2 and #3 surfaces can be coated.

5 In embodiments wherein the #2 and/or #3 surfaces are coated, these coatings can advantageously be low-emissivity coatings and/or solar control coatings. Exemplary low-emissivity coatings are described in U.S. patent application 10/759,971, the entire contents of which are incorporated herein by reference. These coatings commonly comprise a silver or silver-containing film located between two transparent dielectric films.

10 Exemplary solar control coatings are described in U.S. Patent 5,698,262, the entire contents of which are incorporated herein by reference.

One embodiment provides a removable protective masking selected so as to be sufficiently opaque to ultraviolet radiation to substantially preclude (e.g., to have an ultraviolet transmission of less than 30%) ultraviolet radiation from reaching the photocatalytic film underlying the protective masking. In some such cases, an opaque masking film is provided.

In figure 2, a first masking 30 is overlaying first coating 18 and an optional second masking 32 is overlaying fourth coating 36. Each masking preferably comprises a substrate 38 and an adhesive layer 40. In some useful embodiments, adhesive layer 40 comprises an acrylic adhesive. In some useful embodiments, adhesive layer 40 comprises at least one UV stabilizer. One particular group of embodiments provides an adhesive layer 40 comprising an acrylic adhesive that includes at least one UV stabilizer.

In some useful embodiments, adhesive layer 40 comprises at least one hindered amine. Examples of hindered amines that may be suitable in some applications include:

25 bis-(2,2,6,6-tetramethyl-4-piperidyl)sebacate, bis-(1,2,2,6,6-pentamethyl-4-piperidyl)sebacate, polycondensate of succinic acid with N-(2-hydroxyethyl)-4-hydroxy-2,2,6,6-tetramethyl piperidine, poly-([6-[(1,1,3,3-tetramethylbutyl)-imino]-1,3,5-triazine-2,4-diyl] [2-(2,2,6,6-tetramethyl-4-piperidyl)imino]-hexamethylene-[4-(2,2,6,6-tetramethyl-4-piperidyl)imino]), 1-[2-[3-(3,5-di-t-butyl-4-hydroxyphenyl)-propionyloxy]ethyl]-4-[3-(3,5-di-t-butyl-4-hydroxyphenyl)-propionyloxy]-2,2,6,6-tetramethyl piperidine, tetrakis(2,2,6,6-tetramethyl-4-piperidyl)-1,2,3,4-butane tetracarboxylic esters, tetrakis(1,2,2,6,6-pentamethyl-4-piperidyl)-1,2,3,4-butane

30

tetracarboxylic esters, polycondensate of N,N'-bis(2,2,6,6-tetramethyl-4-piperidyl)hexamethylene diamine with 1,2-dibromoethane, and polycondensate of 1,6-bis-(2,2,6,6-tetramethyl-4-piperidylamino)hexane with 2,4-dihalo-6-morpholino-1,3,5-triazine. Adhesive layer 40 may be an acrylic adhesive that includes at least one hindered amine, such as one selected from the group consisting of the list above in this paragraph. The adhesive 40 can optionally include one or more of the hindered amines that comprise tetramethyl piperidine derivatives.

In a preferred embodiment of the present invention, first coating 18 comprises at least one region or thickness comprising photocatalytic film. The photocatalytic film can comprise (e.g., can be) any photoactive material, such as titanium oxide (e.g., TiO₂). The photoactive material preferably is one that characteristically has the ability, at least above certain minimum thicknesses, to absorb ultraviolet radiation and photocatalytically degrade organic materials that contact the photocatalytic film. In certain embodiments, the masking adhesive and the photocatalytic film are jointly selected so as to complement each other. In some cases, the photoactivity of the photocatalytic film is just powerful enough to provide hydrophilicity, without creating a great self-cleaning effect. It has been discovered that providing a particularly powerful photocatalytic film is less than ideal in that such a film tends to leave the coated surface more dirty looking than is ideal. The photocatalytic film can optionally be selected so as to have a level of photoactivity that is just high enough to enable the photocatalytic film to degrade adhesive residue left on the first coating after the masking is removed.

Certain embodiments provide a masked photocatalytic glazing assembly comprising a pane (of a monolithic glazing assembly or a multiple-pane insulating glazing unit) directly on a major surface of which is an exceptionally thin photocatalytic coating (e.g., a coating having at least one region or thickness comprising photocatalytic film), directly on which is a layer of masking adhesive, directly on which is a masking substrate (e.g., a flexible, self-supporting film that can be peeled off the coated major surface, preferably such that when this film is peeled off the coated major surface, the adhesive adheres preferentially to the masking film and does not transfer, at least not substantially, to the coated major surface). Thus, the masking adhesive 40 preferably has a stronger level (or force) of adhesion to the masking substrate than to the coated surface of the pane. For example, in some embodiments, the removable protective masking is a peelable

masking, and the masking adhesive has a higher level of adhesion to the masking substrate than to the photocatalytic coating, such that when the masking is peeled off the coated major surface the adhesive adheres preferentially to the masking substrate. In these embodiments, the masking substrate 38 and/or the masking adhesive 40 optionally
5 comprise at least one UV stabilizer and/or at least one UV blocker. Preferably, UV stabilizer is incorporated into the adhesive.

The photocatalytic film desirably has a level of photoactivity that is low enough that it will not destroy the bond between the adhesive and the masking film or the bond between the adhesive and the pane. Thus, the masking film preferably will not fall or sag
10 off the pane due to the adhesive being unacceptably degraded by photoactivity of the coating 18. Optionally, the photocatalytic film can be selected so as to have a level of photoactivity that is just high enough to enable it to degrade adhesive residue left on the coating 18 when the masking 30 is removed. Preferably, the masking adhesive is selected so that it does not exhibit adhesive transfer when the masking is removed.

15 For purposes of this disclosure, the activity of the photocatalytic film can be measured in terms of a desired photocatalytic reaction rate, such as the removal of a stearic acid test film under exposure to ultraviolet radiation from a light source having an intensity of about 20 watts per square meter at the film surface (e.g., sold commercially by the Q-panel Company of Cleveland, Ohio, U.S.A. under the trademark UVA-340). The
20 ultraviolet radiation intensity can be at least about 20 watts per square meter at the coated surface of the photocatalytic film being tested. The intensity can optionally be set using an ultraviolet meter such as that sold by Ultraviolet Products, Inc. of San Gabriel, California, U.S.A. (e.g., under the trademark BLACK-RAY). The light source can be positioned normal to the coated surface of the photocatalytic film being tested. Exemplary
25 methods are discussed in U.S. Patent No. 6,027,766, the entire contents of which are incorporated herein by reference.

Briefly, the photocatalytic film and the ultraviolet radiation source can be positioned relative to each other so that the ultraviolet radiation passes first through the photocatalytic film and then through the substrate. Here, the light source faces the front of
30 the coated pane. In cases where the pane is formed of material (e.g., glass) through which ultraviolet radiation can pass, the photocatalytic film and the ultraviolet radiation source can be positioned relative to each other so that the ultraviolet radiation passes first through

the pane and then through the photocatalytic film. Here, the light source faces the back of the coated pane. Alternatively, a light source can be positioned on both sides of the pane.

In more detail, an organic contaminant can be applied over the photocatalytic film and upon irradiating the film the ability of the film to remove the contaminant can be observed and measured. Stearic acid ($\text{CH}_3(\text{CH}_2)_{16}\text{COOH}$) is one useful contaminant. Stearic acid can be applied over the photocatalytic film as a thin test film by any desired technique, such as by spray coating, dip coating, or spin coating. Stearic acid test film thicknesses can optionally range between about 100 angstroms and about 200 angstroms. The test film, for instance, can be applied as stearic acid in a methanol solution, such as a solution having a concentration of 6×10^{-3} moles of stearic acid per liter of solution.

The reported method for measuring the activity of the photocatalytic film is to measure the integrated intensity of the carbon-hydrogen stretching vibrational absorption bands of the stearic acid on the photocatalytic film. The integrated intensity reflects the thickness of stearic acid test film on the photocatalytic film. As the stearic acid test film is removed, this is believed to result in a drop of the carbon-hydrogen stretching vibrational band intensity. The carbon-hydrogen bonds in the stearic acid absorb infrared radiation which unlike ultraviolet radiation does not activate the photocatalytic film. Generally, such absorption occurs between 2800 and 3000 cm^{-1} wave numbers, and can be measured with a Fourier Transform Infrared Spectrophotometer. This spectrophotometer can be equipped with a detector like a deuterated triglycine sulfide detector or a mercury-cadmium-telluride detector. The mercury-cadmium-telluride detector is reported to be preferred, particularly where the pane, the photocatalytic film, or another film on the pane absorb the infrared radiation that is used by the spectrophotometer to generate the absorption spectrum. When infrared radiation is so absorbed, the infrared radiation that passes through the stearic acid test film is reduced. This is combined with a low concentration of stearic acid on the photocatalytic film. Given this, the mercury-cadmium-telluride detector is reported to provide a spectrum with a signal-to-noise ratio that is about an order of magnitude better than a deuterated triglycine sulfide detector. When the activity of a stearic acid test film deposited over the photocatalytic film is tested, the infrared radiation can optionally be directed through the pane and the photocatalytic film onto a detector on an opposite side of the pane being tested. Where infrared radiation is not able to pass through the substrate, the infrared radiation can optionally be directed

over the surface at an angle, passing through the test film and reflecting off of the pane. Such method is known as reflection IR spectroscopy.

Thus, it is possible to consider the reaction rate of a photocatalytic film by measuring the rate at which the photocatalytic film reacts to remove the stearic acid test film when the photocatalytic film is exposed to actinic radiation. The rate of decrease in the integrated intensity of the carbon-hydrogen stretching vibrational feature is reported to be directly proportional to the surface coverage. Increasing the time of exposure to actinic (ultraviolet) radiation then gives the reaction rate. An initial activity can be measured with the spectrophotometer for a stearic acid test film on the photocatalytic film 18. The photocatalytic film can optionally have been exposed to ultraviolet radiation for the initial activity measurement. The stearic acid coated photocatalytic film can then be exposed to ultraviolet radiation for a certain time period, at the end of which a second activity measurement can be made with the spectrophotometer. The integrated intensities of the carbon-hydrogen stretching vibrations in the second measurement should be lower than in the first measurement, as a portion of the stearic acid test film will have been removed due to exposure to ultraviolet radiation. From such two measurements, one can generate a curve of integrated intensity of carbon-hydrogen stretching vibrations versus time. The slope of such a curve gives the reaction rate. While two points can be plotted to give a curve, several measurements are preferably taken to give the curve. While the period of exposure to radiation between measurements can be kept constant or varied when taking more than two measurements (e.g., the cumulated time of exposure to ultraviolet radiation is used to plot the curve), the intensity and orientation of the ultraviolet radiation should be kept constant for all measurements taken when determining the reaction rate.

Certain embodiments of the invention provide a photocatalytic coating 18 that has a low level of photoactivity and is used when a masking film is carried directly against (e.g., via a masking adhesive sandwiched between the coating 18 and the masking substrate) the photocatalytic coating 18. The reaction rate reported herein is given in units of $\text{cm}^{-1}\text{min}^{-1}$. Higher values of reaction rate signify greater photoactivity. In certain embodiments, the coating 18 has a photocatalytic activity of less than $1 \times 10^{-2} \text{ cm}^{-1}\text{min}^{-1}$, less than $9 \times 10^{-3} \text{ cm}^{-1}\text{min}^{-1}$, less than $8 \times 10^{-3} \text{ cm}^{-1}\text{min}^{-1}$, less than $4 \times 10^{-3} \text{ cm}^{-1}\text{min}^{-1}$, less than $3 \times 10^{-3} \text{ cm}^{-1}\text{min}^{-1}$, less than about $2 \times 10^{-3} \text{ cm}^{-1}\text{min}^{-1}$, or even less than about $1.5 \times 10^{-3} \text{ cm}^{-1}\text{min}^{-1}$.

One embodiment provides: a pane (optionally a glass pane) having a first major surface directly over which is applied a photocatalytic coating 18 (comprising an active film comprising, consisting essentially of, or consisting of titania, the active film preferably having a thickness of less than about 150 angstroms, such as between 20
5 angstroms and 100 angstroms, or less than 100 angstroms, perhaps between 20 angstroms and 75 angstroms, and in some cases less than 75 angstroms, such as between 20 angstroms and 60 angstroms), the photocatalytic coating 18 preferably having a particularly low photocatalytic activity (optionally, though not necessarily, being within one or more of the ranges noted above, such as less than $9 \times 10^{-3} \text{ cm}^{-1} \text{ min}^{-1}$, less than $5 \times 10^{-3} \text{ cm}^{-1} \text{ min}^{-1}$, or even less than about $1.5 \times 10^{-3} \text{ cm}^{-1} \text{ min}^{-1}$), wherein a masking is carried by the photocatalytic coating 18 (e.g., such that the masking comprises a masking adhesive sandwiched directly between the photocatalytic coating 18 and a masking substrate). In these embodiments, the photocatalytic coating 18 (or at least a titania-comprising film thereof) can optionally be a sputtered film. In other embodiments, though, the
15 photocatalytic coating is applied by another thin film deposition technique, such as chemical vapor deposition, vacuum evaporation, and/or ion-assisted deposition. Wet chemistry methods (e.g., sol-gel techniques) can also be used.

Thus, in certain embodiments, the photocatalytic thin film coating comprises an active film comprising titania, and the active film has a thickness of less than 100
20 angstroms, or even less than 75 angstroms.

In embodiments wherein the photocatalytic coating comprises (e.g., is) a sputtered film, various sputter deposition techniques can be used. In certain particularly preferred embodiments, the photocatalytic coating 18 (or at least one film region thereof) is deposited by sputtering at a low temperature (e.g., while maintaining the substrate at
25 below about 250 degrees Celsius, and more preferably below 200 degrees Celsius).

Sputtering is well known in the present art. Magnetron sputtering chambers and related equipment are commercially available from a variety of sources (e.g., Leybold). Useful magnetron sputtering techniques and equipment are described in U.S. Patent 4,166,018, issued to Chapin, the entire teachings of which are incorporated herein by
30 reference.

In certain favored methods of the invention, the photocatalytic coating 18 is applied to a substrate in a multiple-chamber sputtering line. Sputtering lines are well

known in the present art. A typical sputtering line includes a series of sputtering chambers aligned and connected such that a sheet-like substrate can be passed from one chamber to the next by conveying the substrate horizontally over (e.g., while in direct contact with) spaced-apart transport rollers in each of the chambers (the rollers form a continuous path
5 of substrate travel through the sputtering line). The substrate is typically conveyed at speeds of between about 100-500 inches per minute.

In one particular method, the substrate is positioned at the inlet of the sputtering line and conveyed to a desired coat zone. This coat zone is provided with three cathodes that are adapted to deposit the first film. In more detail, each of these cathodes comprises
10 a silicon sputtering target, though, other methods involve other materials for the first film (alternatively, this first film can be omitted entirely). The silicon targets in this coat zone can be sputtered in an oxidizing atmosphere to deposit a silicon dioxide film directly upon the first major surface of the substrate. This atmosphere may consist essentially of oxygen (e.g., about 100% O₂). Alternatively, this atmosphere may comprise Ar/O₂ (e.g., oxygen
15 and up to about 40% argon). A power of about 38 kW can be applied to the first cathode, while a power of about 38 kW can be applied to the second cathode, and a power of about 38 kW can be applied to the third cathode. The substrate can be conveyed beneath all three of these targets at a rate of about 200 inches per minute, while sputtering each of these targets at the noted power level, such that a silicon dioxide film is applied at a
20 thickness of about 100Å. The silica film here can optionally be less than 100 angstroms, such as between 60 angstroms and 90 angstroms, e.g., about 75 angstroms. The thickness and composition of this optional first film can be varied as desired. In embodiments wherein one or more silicon targets are used, each silicon target can include some aluminum or another material to enhance the conductivity of the target.

25 The thus coated substrate can then be conveyed into a subsequent coat zone. In this zone, three cathodes are used to deposit a second film. Preferably, each of these three cathodes comprises a titanium sputtering target. The titanium targets in this coat zone can be sputtered in an oxidizing atmosphere to deposit a titanium dioxide film directly upon the optional first film, when provided. Alternatively, such a titanium dioxide film can be
30 deposited directly upon the substrate. Still further, two or more films can be deposited between the substrate and the titanium dioxide film. The atmosphere in which the titanium dioxide film is deposited may consist essentially of oxygen. Alternatively, this

atmosphere may comprise Ar/O₂. A power of about 43 kW can be applied to the first cathode, a power of about 43 kW can be applied to the second cathode, and a power of about 43 kW can be applied to the third cathode. The substrate can be conveyed beneath all three of these targets at a rate of about 200 inches per minute, while sputtering each of these targets at the noted power level, such that a titanium dioxide film is applied at a thickness of about 100Å. The titania film here can optionally be less than 100 angstroms, such as between 20 angstroms and 60 angstroms, e.g., about 25-40 angstroms. The thickness and composition of this film can be varied. In the present method, this titanium dioxide forms the outermost portion of the coating 18, although other embodiments involve an overlying thin film that does not eliminate the hydrophilicity imparted by the titanium dioxide. To achieve certain hydrophilicity properties (e.g., night-time properties), the titania can optionally be mixed with silica (or another non-photoactive, but hydrophilic, dielectric material). This can be done to achieve a desired balance of hydrophilic and photoactive properties, and may provide a suitably low level of activity to promote good masking durability. Preferably, directly over the outermost face of the coating 18 there is adhesively applied a first masking 30. This masking 30 can be applied as one single sheet of masking material or as a plurality of elongated masking strips applied in a sequentially-overlapping fashion wherein adjacent strips are overlapped in a side-over-side overlapping arrangement (e.g., as illustrated in figure 4). Optionally, the masked pane surface has a central region (e.g., which comprises the very center of the area of the masked pane surface), and one or more adhered masking strips are located over (e.g., so as to cover and extend beyond) this central region.

In the method just described, it is to be appreciated that the second major surface of the substrate may previously have been, or may subsequently be, coated with an optional low-emissivity coating. For instance, the coat zones just described for use in depositing the first and second films can be sputter-up coat zones (e.g., optionally located at the end of a sputtering line that includes a relatively large number of preceding sputter-down coat zones in which the optional low-emissivity coating may have been applied). Particularly useful sputter-up/sputter-down methods and equipment are described in U.S. patent application 09/868,542, the entire contents of which are incorporated herein by reference.

In certain embodiments, the invention provides a high efficiency production process for masked photocatalytic insulating glass technology. Here, the method involves a first stage sputter deposition process, followed by a second stage masking application process. The masking application is optionally carried out by operating a masking station
5 that is part of an insulating glass unit assembly line. Reference is made to the process of figure 11 and the coater of figure 12. Preferably, the process includes: conveying a first glass sheet through a coater (e.g., a coater comprising a plurality of deposition bays/chambers connected in series along a continuous path of substrate travel), coating a first major surface of the glass sheet by upward sputtering, and coating a second major
10 surface of the glass sheet by downward sputtering: then, the thus coated first glass sheet is conveyed along an insulating glass unit assembly line on which the first glass sheet is assembled together with a second glass sheet to form an insulating glass assembly; then, a peelable first masking is applied over the coated first surface of the first glass sheet by adhering masking adhesive directly to the coated first surface of the first glass sheet. In
15 some embodiments, this masking application is carried out by operating a masking station that is part of the insulating glass unit assembly line. In one embodiment, this masking station is located at the end of the assembly line.

Figure 12 depicts an exemplary coater 2000 useful in the present production process. Here, the coater 2000 is seen to include at least six sputter deposition bays,
20 although this is not required. The coater may advantageously include at least nine such bays, at least twelve such bays, or even at least fifteen such bays. The illustrated coater has as its last bay 200 (i.e., the last active bay along the path of substrate travel) a sputter-up bay/chamber. In another embodiment, the coater has a sputter-up bay/chamber as the first active bay on the path of substrate travel P. The illustrated chamber 2000 is shown as
25 having a combination of transport rollers 210 and conveyor belts 144C-144G, although it may be preferable to simply use spaced-apart transport rollers (which are unconnected by a conveyor belt). In the illustrated coater, the first five bays are sputter-down bays, while the last bay is a sputter-up bay. As noted above, however, the arrangement and location of sputter-up bays and sputter-down bays can be adjusted to maximize efficiency or product
30 integrity. Each illustrated bay is provided with two targets 166A-166J, 660A, 660B, although this is by no means required (e.g., a given chamber may have one target, three or more targets, or no targets, depending on the desired process).

One group of embodiments provides a method of processing substrates, where the method involves providing a first glass sheet, conveying this sheet through a single sputter coater, and sputter depositing coatings onto both first and second major surfaces of the glass sheet in a single pass of the sheet through the sputter coater. In the present group of
5 embodiments, this sputter depositing involves applying a photocatalytic coating to the first major surface 20 of the glass sheet 12 by sputtering upwardly from a first sequence of targets 660A, 660B. Here, the first sequence of targets optionally includes one or more targets comprising a sputterable target material selected from the group consisting of a pure or substantially pure titanium material, a titanium alloy material, a titanium oxide
10 material, and a compound including titanium and silicon. This upward sputtering can optionally be carried out in a gaseous sputtering atmosphere containing an oxidizing gas and/or an inert gas. Suitable targets are available commercially from a number of suppliers, such as TICO Titanium Inc., New Hudson, Michigan, U.S.A. Substoichiometric TiO_x targets, where x is less than 2, are described in U.S. Patent Nos. 6,461,686 and
15 6,468,402 and 6,511,587, the entire contents of each of which are incorporated herein by reference. Substoichiometric TiO_x targets are commercially available from Bekaert VDS nv (Deinze, Belgium). Conjointly, the sputter depositing involves applying a low-emissivity coating to the second major surface of the first glass sheet by sputtering downwardly from a second sequence of targets. Here, the second sequence of targets
20 optionally includes one or more targets comprising a sputterable target material selected from the group consisting of a pure or substantially pure silver material and a silver alloy material. Suitable targets of this nature are readily available from a number of commercial suppliers. The thus coated first glass sheet is then delivered to (e.g., positioned on) a multiple-pane insulating glazing unit assembly line and conveyed along the assembly line,
25 on which this first glass sheet is assembled with a second glass sheet such that the resulting insulating glass assembly bounds a gap between the first and second glass sheets (the coated first major surface of the first glass sheet being an exterior surface oriented away from the gap). A peelable first masking is applied over the photocatalytic coating. The masking preferably comprises a masking substrate and a masking adhesive. The
30 application of the first masking over the photocatalytic coating involves adhering the masking adhesive directly to the photocatalytic coating. The applied masking adhesive desirably is selected so as to have a higher level of adhesion to the masking substrate than

to the photocatalytic coating. In some cases, the application of the first masking over the photocatalytic coating involves operating a first masking station that is part of (i.e., is located on) the assembly line. Optionally, the present method includes applying a peelable second masking over a #4 surface of the resulting insulating glass assembly by operating a
5 second masking station, which can advantageously be part of the assembly line as well.

In some of the embodiments described in the immediately preceding paragraph, the photocatalytic coating comprises an active film comprising titania, and this active film is sputter deposited at a thickness of less than 100 angstroms, as described below. Additionally or alternatively, the photocatalytic coating can optionally comprise an active
10 film comprising titania, and this active film can be sputter deposited directly over an amorphous film.

In the present group of embodiments, the method can further comprise peeling the first masking off the major surface bearing the photocatalytic coating. During this peeling, the adhesive in some embodiments adheres preferentially to the masking substrate such
15 that substantially all of the adhesive remains on the masking substrate once the first masking has been peeled off the major surface bearing the photocatalytic coating. As noted above, the masking adhesive can optionally be an acrylic adhesive, and/or the masking substrate can optionally comprises polyethylene, and/or the masking adhesive can optionally comprise at least one UV stabilizer.

It has been discovered that particularly thin photocatalytic coatings (optionally
20 comprising sputtered titania) can provide exceptional results insofar as the above characteristics and advantages are concerned. In some embodiments, the photocatalytic coating has a total thickness of less than about 500 angstroms, preferably less than about 400 angstroms, perhaps less than about 300 angstroms, or even less than 200 angstroms
25 (e.g., between 20 angstroms and 175 angstroms).

Certain embodiments involve a photocatalytic thin film coating comprising an active film comprising titania, the active film being deposited directly over an underlying film having a thickness of less than 200 angstroms, less than 100 angstroms, or even less than 75 angstroms. Moreover, in some cases, the titania-comprising film has no more than
30 200 angstroms, or no more than 100 angstroms, of total underlying film between it and the substrate.

In some embodiments, the photocatalytic thin film coating comprises an active film comprising titania, and the active film is deposited (i.e., positioned) directly over an amorphous film. The amorphous film, for example, can be a silica film, optionally comprising one or more metals (e.g., aluminum). In some cases, the amorphous film has a composition adapted to maintain a morphology that is at least substantially amorphous when subjected to glass tempering. A film comprising silica and a small amount of one or more metals is useful. Thus, in figure 2, for example, the innermost thickness (i.e., the thickness nearest the first pane 12) of the coating 18 can be a film underlying an active titania-comprising film (the active film optionally forming the outermost thickness of the coating 18).

It is often necessary to heat coated glass sheets to temperatures at or near the melting point of glass to temper the glass or to enable it to be bent into desired shapes. Tempering is desirable for glass used in automobile windows, for example, and particularly for glass used in automobile windshields. Further, tempered glass is commonly required in particular areas of buildings. Upon breaking, tempered glass desirably exhibits a break pattern in which the glass shatters into many small pieces, rather than into large dangerous shards. During glass tempering, coated glass is commonly subjected to elevated temperature on the order of about 700 degrees C.

In some embodiments, the invention provides a method that includes tempering a coated pane after the photocatalytic thin film coating has been applied to the substrate but before applying the removable protective masking over the photocatalytic thin film coating. Here, the photocatalytic coating will commonly be exposed (i.e., not covered) during the tempering. Preferably, the pane is glass and the heat treatment comprises: providing a coated glass of the described nature; and subjecting the thus-coated glass to an elevated temperature of between about 400 degrees C and about 750 degrees C, preferably between about 500 degrees C and about 750 degrees C, and perhaps more preferably between about 600 degrees C and about 750 degrees C. The tempering is preferably performed in an oxidizing atmosphere. For example, a single load of glass sheets can be positioned in a convection-type furnace and exposed to elevated temperatures reaching about 734 degrees C. The time taken to reach this temperature can be about 109 seconds. The coated glass can then be air quenched.

Following such an optional tempering procedure, the coated glass can be incorporated into a multiple pane IG unit, and the removable masking can be applied after the panes have been assembled into the IG unit, the method thus involving providing tempered glass panes, assembling two such panes into an IG unit, and thereafter applying the masking to the exterior major surface (e.g., the #1 surface) of one of the panes, optionally applying masking to both of the IG unit's exterior major surfaces (e.g., #1 and #4 surfaces). Here, the masking application can optionally be carried out on the same assembly line where the panes are assembled together into IG unit assemblies (e.g., on the same conveyor path).

The photocatalytic coating can be deposited by a variety of thin film deposition techniques. In certain preferred embodiments, this coating is applied by sputtering. Sputtering has been considered not to provide high levels of photoactivity. Thus, in embodiments of the invention providing one or more thin sputtered photocatalytic coatings that are masked, the inventors have turned this to their advantage by providing a masked, low-photoactivity coating that has masking stability and good hydrophilic coating properties upon removing the masking film, preferably without the high levels of photoactivity that have been found to result in less than ideal results in terms of the coated surface keeping a clean appearance.

Figure 3 is a cross-sectional view of an insulating glazing unit 200 in accordance with an additional exemplary embodiment of the present invention. Insulating glazing unit 200 comprises a first pane 12, a second pane 14, and a spacer 16 interposed between first pane 12 and second pane 14. The spacer 16 in some embodiments can be integral to a sash, frame, etc. Insulating glazing unit has a #1 surface 20, a #2 surface 22, a #3 surface 24 and a #4 surface 26. With reference to figure 3, it will be appreciated that first pane 12 comprises #1 surface 20 and #2 surface 22. In the embodiment of figure 3, a first coating 18 is disposed on the #1 surface 20. Also in the embodiment of figure 3, a second coating 28 is disposed on the #2 surface. Second pane 14 of insulating glazing unit 200 comprises #3 surface 24 and #4 surface 26. With reference to figure 3, it will be appreciated that the #3 and #4 surfaces are uncoated. Here, the coated #1 surface carries a first masking 30 and the uncoated #4 surface carries a second masking 32. The first coating 18 desirably comprises (e.g., is) a photoactive coating, such as any of those described in the present disclosure.

Figure 4 is a perspective view of an assembly 300 in accordance with an exemplary embodiment of the present invention. Assembly 300 includes an insulating glazing unit 302. Insulating glazing unit 302 includes a first pane 304, a second pane 306 and a spacer 308 interposed between first pane 304 and second pane 306. First pane 304, second pane 306, and spacer 308 preferably define a between-pane space. In some embodiments, an insulative gas (e.g., argon, krypton, and/or others) is disposed within the between-pane space. Embodiments are also possible in which the between-pane space contains air or vacuum. Insulating glazing unit 302 may be generally referred to as a double glazed unit. Other embodiments of insulating glazing unit 302 are possible without deviating from the spirit and scope of the present invention. For example, insulating glazing unit 302 may be a single glazed unit or a triple glazed unit. The insulating glazing unit in any embodiment hereof can optionally be an insulating glass unit and/or can have a major dimension of less than 4 meters, less than 3 meters, less than 2.5 meters, less than 2 meters, or even less than 1.7 meters.

First pane 304 of insulating glazing unit 302 has a first face 320. In the embodiment of Figure 4, a temporary removable protective covering (or “masking”) 324 is disposed over first face 320 of first pane 304. In the embodiment of Figure 4, protective covering 324 comprises a plurality of masking strips, each comprising a masking substrate (which preferably is flexible/non-rigid, such as a plastic or plastic-like material, optionally comprising polyethylene) with a masking adhesive disposed over a surface of the masking substrate.

Figure 5 is an isometric view of a workstation 100 that can be used to apply a masking 102 to a monolithic pane or an insulating glazing unit 10. Workstation 100 includes a frame 104 supporting a work platen 106. The conveyor 108 can optionally take from (i.e., be adapted to receive glass pieces from) a preceding conveyor that is part of the assembly line on which monolithic panes are assembled together to form multiple-pane IG unit assemblies. Workstation 100 also includes a conveyor 108 extending across the front surface of work platen 106. Conveyor 108 may be utilized to transport a monolithic pane or an insulating glazing unit 10 through workstation 100. Conveyor 108 includes a belt 120 and a plurality of rollers 122. In the embodiment of figure 5, insulating glazing unit 10 is shown resting on belt 120 of conveyor 108. Workstation 100 may be incorporated into (e.g., may be part of) a longer assembly line having multiple work stations, each

having a different function or effecting a step in processing a monolithic pane or an insulating glazing unit 10.

As noted above, some embodiments of the present invention include an insulating glazing unit that is masked on both sides. Figure 6 is an isometric view showing a process involving a production line 124 that is capable of applying masking to both sides of a monolithic pane or an insulating glazing unit. Production line 124 comprises a first workstation 130, a second workstation 132 and a third workstation 134. In this exemplary embodiment, first workstation 130 and third workstation 134 each comprise a workstation (optionally like workstation 100 shown in the previous figure) that is capable of applying protective covering (e.g., masking) 324 to a monolithic pane or an insulating glazing unit. Second workstation 132 is adapted for flipping an insulating glazing unit after the insulating glazing unit leaves first workstation 130 so that a masking can be applied to a second side 138 of the monolithic pane or insulating glazing unit by third workstation 134.

Insulating glazing units may be advanced through first workstation 130, second workstation 132 and third workstation 134 as part of a process for applying masking to both sides of the insulating glazing unit. In the embodiment of figure 6, a first insulating glazing unit 302 is disposed in a first workstation 130, a second insulating glazing unit 302' is disposed in second workstation 132 and a third insulating glazing unit 302'' is disposed in third workstation 134.

First workstation 130 includes a first tool 328, a second tool 330, and a roll 332 of masking material 336. In the embodiment of figure 6, a plurality of sections 334 of masking material 336 have been applied to a first side 136 of first insulating glazing unit 302. First insulating glazing unit 136 also includes a second side 138. With reference to figure 6, it will be appreciated that the sections 334 of masking material 336 are positioned and dimension such to form a protective covering 324. In figure 6, an unmasked apron 344 is shown extending between protective covering (or "masking") 324 and an outer periphery of first insulating glazing unit 302. Preferably, when masking strips are secured to (e.g., when they are pressed adhesively onto) a major surface of a monolithic pane or a desired pane of an insulating glazing unit, they are spaced by an apron from the edge 84 of the pane so that no subsequent trimming of the masking is performed. Thus, in certain embodiments, there is provided a monolithic pane or IG unit having a major surface bearing a photocatalytic coating, and the method involves applying a masking (optionally

comprising multiple strips, as described herein) adhesively over the photocatalytic coating (optionally so as to cover all but a peripheral area, or “apron”, of the coated surface) without performing any subsequent cutting of the applied masking once it has been adhered to (e.g., so as to lie in its entirety parallel to) the coated surface. This can be done
5 to avoid scoring the coating.

In figure 6, a second insulating glazing unit 302' is disposed in second workstation 132. With reference to figure 6, it will be appreciated that second insulating glazing unit 302' is oriented so that that the relative positions of first side 136 and second side 138 are reversed relative to first insulating glazing unit 302. A protective covering 324 that is
10 disposed on first side 136 of second insulating glazing unit 302' is illustrated using dashed lines in figure 6. Third workstation 130 includes a first tool 328, a second tool 330, and a roll 332 of masking material 336. In the embodiment of figure 6, a plurality of sections 334 of masking material 336 have been applied to the second surface of third insulating glazing unit 302''.

15 A method of masking both sides of a monolithic pane or an insulating glazing unit in accordance with the present invention includes the following steps. Transporting a monolithic pane or an insulating glazing unit 10 into first workstation 130. Applying protective covering (or “masking”) 324 to a first side 136 of insulating glazing unit 10 (preferably over a photocatalytic coating 18). Transporting the monolithic pane or
20 insulating glazing unit into second workstation 132. Flipping the monolithic pane or insulating glazing unit. Transporting the monolithic pane or insulating glazing unit into the third workstation 134. Applying protective covering 324 to the second side 138 of the monolithic pane or insulating glazing unit (e.g., by operating the third workstation 134).

25 With respect to the monolithic pane or multi-pane insulating glazing unit, a variety of pane substrates are suitable. Preferably, the substrate is a sheet-like substrate having generally or substantially opposed first and second major surfaces. In many embodiments, the substrate is a sheet of transparent material (i.e., a transparent sheet). The substrate, however, is not required to be transparent. For most applications, though, the substrate will comprise a transparent (or at least translucent) material, such as glass or clear plastic.
30 For example, the substrate is a glass sheet (e.g., a glass window pane) in preferred embodiments. A variety of known glass types can be used, and soda-lime glass is commonly preferred. In some embodiments, each pane of a masked photocatalytic IG unit

is a sheet of glass and the masking material is a transparent (e.g., optically clear) polymeric material, wherein optionally the IG unit has only two glass panes, the #1 and #4 surfaces of the IG unit are masked, the #1 surface bears the photocatalytic coating, and the #4 surface does not have any thin film coating underneath the masking.

5 Substrates (e.g., panes) of various sizes can be used in the present invention. Commonly, large-area substrates are used. Certain embodiments involve a substrate having a width of at least about .5 meter, preferably at least about 1 meter, perhaps more preferably at least about 1.5 meters (e.g., between about 2 meters and about 4 meters), and in some cases at least about 3 meters.

10 Substrates of various thicknesses can be used in the present invention. Commonly, substrates (e.g., glass sheets) having a thickness of about 1-5 mm are used. Certain embodiments involve a substrate with a thickness of between about 2.3 mm and about 4.8 mm, and perhaps more preferably between about 2.5 mm and about 4.8 mm. In some cases, a sheet of glass (e.g., soda-lime glass) with a thickness of about 3 mm will be used.

15 The masking can comprise a variety of materials. For example, the masking substrate will commonly be a film (which may be flexible, yet self supporting). Polymeric films are useful. For example, the masking substrate can be polyethylene (PE), polypropylene (PP), polyvinyl chloride (PVC), polyurethane, polytetrafluoroethylene (PTFE), polyester (e.g., PET), polyamide, or polyimide. The masking substrate may also
20 be a mixture of films, such as a co-extruded polyethylene-polypropylene film. Useful masking films are commercially available from a number of suppliers, including Permacel (New Brunswick, New Jersey, USA), Poli-Film America (Hampshire, Illinois, USA), and American Biltrite Inc. (Morristown, New Jersey, USA), and Tekra Corporation (New Berlin, Wisconsin, USA).

25 In some particular embodiments, the masking adhesive is an acrylic adhesive and the masking substrate comprises (e.g., is) polyethylene. These embodiments are advantageous when it is desired to provide a peelable masking where the masking adhesive has a higher level of adhesion to the masking substrate than to the coated major surface, such that when the masking is peeled off the coated major surface the adhesive
30 adheres preferentially to the masking film.

Figure 7 is a diagrammatic top view of an assembly in accordance with an exemplary embodiment of the present invention. The assembly of figure 7 includes an

insulating glazing unit 302 (which in other embodiments can be replaced with a monolithic pane) and a first sash piece 338. In figure 7, it can be appreciated that a first protective covering 324 comprising a first masking strip 342 is disposed on a first (e.g., outboard) surface 346 of insulating glazing unit 302 and a second protective covering (or “masking”) 324' is disposed on a second surface 348 of insulating glazing unit 302. In the embodiment of figure 7, a first unmasked apron 344 of first surface 346 extends between an outer periphery of first protective covering 324 and an outer periphery of insulating glazing unit 302. Similarly, a second unmasked apron 344' of second surface 348 extends between an outer periphery of second protective covering 324' and an outer periphery of insulating glazing unit 302. In the embodiment of figure 7, first unmasked apron 344 and second unmasked apron 344' each have a width W1. In the embodiment of figure 7, an optional adhesive bead 350 has been deposited on second unmasked apron 344' of second surface 348.

A first mating portion 352 and a second mating portion 352' of first sash piece 338 (which preferably comprises a rigid support member) are shown in figure 7. In the embodiment of figure 7, first mating portion 352 and second mating portion 352' both have a width W2. In the exemplary embodiment of figure 7, width W2 of first mating portion 352 is generally similar to (optionally substantially equal to) width W1 of second unmasked apron 344'. In some alternate embodiments of the present invention, the width of the second unmasked apron 344' is generally greater than the width of the mating portion of a sash piece. As another alternative, W1 can advantageously be smaller than W2.

Figure 8 is a diagrammatic top view of an assembly 202 comprising insulating glazing unit 302 and first sash piece 338 shown in the previous figure. In figure 8 it may be appreciated that second unmasked apron 344' has been mated with first mating portion 352 and second mating portion 352' of first sash piece 338. Insulating glazing unit 302 may be fixed to first sash piece 338, for example, using an adhesive material. A second sash piece 340 is also shown in figure 8. Assembly 202 has a viewing area (or “vision area”) 356 that is not covered by first sash piece 338 or second sash piece 340. Here, the masking can optionally cover substantially the entire vision area.

Figure 9 is a perspective view of an assembly in accordance with an additional exemplary embodiment of the present invention. A first wall 590 of a building 580 is visible in figure 9. First wall 590 defines an opening 582. An insulating glazing unit 588 is disposed in opening 582 defined by first wall 590. Insulating glazing unit 588 comprises a first pane 584 defining a #1 surface 576 of insulating glazing unit 588. In the embodiment of figure 9, a first coating 572 is disposed on #1 surface 576. First coating 572 on the #1 surface carries (e.g., is covered by) a first masking 574. In some useful embodiments, first coating 572 comprises a photocatalytic coating, such as any one of those described above. Preferably, the masking 574 covers more of the vision area than is illustrated in figure 9, such as all or substantially all of the vision area.

Figure 10 is a cross sectional view illustrating an assembly in accordance with an additional exemplary embodiment of the present invention. A first wall 690, a second wall 692 and a third wall 694 of a building 680 are visible in figure 10. First wall 690, second wall 692 and third wall 694 define an interior 668 of a room 670. First wall 690 defines an opening 682. An insulating glazing unit 688 is disposed in opening 682 defined by first wall 690.

Insulating glazing unit 688 comprises a first pane 684 defining a #1 surface 676 of insulating glazing unit 688 and a second pane 686 defining a #4 surface of insulating glazing unit 688. In the embodiment of figure 10, a first coating 672 is disposed on #1 surface 676. First coating 672 on the #1 surface carries (e.g., is covered by) a first masking 674. In some useful embodiments, first coating 672 comprises a photocatalytic coating, such as any one of those described above.

In the embodiment of figure 10, masking 674 comprises a substrate and an adhesive layer. In figure 10, rays of sunlight 664 are shown passing through masking 674 and insulating glazing unit 688. In some useful embodiments of the present invention, masking 674 is sufficiently optically translucent (e.g., having a visible transmission of at least at least 30%, at least 40%, at least 50%, or at least 60%) to allow sunlight to illuminate room 670. In some useful embodiments of the invention, masking 674 is transparent (or at least substantially transparent) to visible radiation (e.g., has a visible transmission above 65%, 75%, or even 85%).

In some useful methods in accordance with the present invention, masking 674 remains fixed to insulating glazing unit 688 while a number of people (e.g., carpenters,

painters, etc.) complete the erection and/or finishing of a building (e.g., house, office building, etc.) to which the insulating glazing unit 688 is attached (e.g., mounted). When this is the case, masking 674 may serve to protect insulating glazing unit 688 from damage while, at the same time, allowing room 670 to be illuminated by sunlight 664. Sunlight
5 664 may allow carpenters, painters, and other workers to perform work on building 680 without the use of artificial light.

Some further embodiments provide an apparatus comprising: at least one wall defining a room; the wall defining an opening; an insulating glazing unit disposed in the opening defined by the wall, the insulating glazing unit comprising two spaced-apart panes
10 having a gap between them; a photocatalytic thin film coating on a desired major surface of one of the panes, the desired major surface being an exterior surface facing away from the gap; and a removable protective masking overlaying the photocatalytic thin film coating, the masking comprising a masking substrate and a masking adhesive, wherein the masking adhesive is in direct adhesive contact with the photocatalytic thin film coating.
15 . Optionally, the protective cover is sufficiently translucent, or transparent, to allow sunlight to illuminate the room. In some cases, the photocatalytic film has a thickness and composition selected such that the photocatalytic film is capable of degrading adhesive residue left on the coating after the selected masking is removed.

Numerous characteristics and advantages of the invention covered by this
20 document have been set forth in the foregoing description. It will be understood, however, that this disclosure is, in many respects, only illustrative. Changes may be made in details, particularly in matters of shape, size and ordering of steps without exceeding the scope of the invention. The invention's scope is, of course, defined by the language in which the appended claims are expressed.

WHAT IS CLAIMED IS:

1. A method of processing substrates, the method comprising:
 - a) providing a first sheet of glass, said first glass sheet having opposed first and second major surfaces;
 - 5 b) conveying the first glass sheet through a single sputter coater, and sputter depositing coatings onto both the first and second major surfaces in a single pass of the first glass sheet through the sputter coater, said sputter depositing involving:
 - 10 i) applying a photocatalytic coating to the first major surface of the first glass sheet by sputtering upwardly from a first sequence of targets, said first sequence of targets including one or more targets comprising a sputterable target material selected from the group consisting of a pure or substantially pure titanium material, a titanium alloy material, a titanium oxide material, and a compound including titanium and silicon;
 - 15 ii) applying a low-emissivity coating to the second major surface of the first glass sheet by sputtering downwardly from a second sequence of targets, said second sequence of targets including one or more targets comprising a sputterable target material selected from the group consisting of a pure or substantially pure silver material and a silver alloy material;
 - 20 c) delivering the thus coated first glass sheet to a multiple-pane insulating glazing unit assembly line;
 - d) conveying the thus coated first glass sheet along the assembly line and assembling such first glass sheet with a second glass sheet, such that the resulting insulating glass assembly bounds a gap between said first and second glass sheets and the coated first major surface of said first glass sheet is an exterior surface oriented away from
25 said gap; and
 - e) applying a peelable first masking over the photocatalytic coating, said first masking comprising a masking substrate and a masking adhesive, wherein said application of the first masking over the photocatalytic coating involves adhering the masking adhesive directly to the photocatalytic coating.
- 30 2. The method of claim 1, wherein the photocatalytic coating comprises an active film comprising titania, said active film being sputter deposited at a thickness of less than 100 angstroms.

3. The method of claim 1, wherein the photocatalytic coating comprises an active film comprising titania, the active film being sputter deposited directly over an amorphous film.

4. The method of claim 1, wherein said application of the first masking over the photocatalytic coating involves operating a first masking station, said first masking station being part of said assembly line.

5. The method of claim 1, comprising applying a peelable second masking over a #4 surface of said resulting insulating glass assembly by operating a second masking station, said second masking station also being part of said assembly line.

6. The method of claim 1, wherein said applied masking adhesive has a higher level of adhesion to the masking substrate than to the photocatalytic coating.

7. The method of claim 6, further comprising peeling the first masking off the major surface bearing the photocatalytic coating, during which peeling the adhesive adheres preferentially to the masking substrate such that substantially all of the adhesive remains on the masking substrate of the first masking once the first masking has been peeled off the major surface bearing the photocatalytic coating.

8. The method of claim 1, wherein the masking adhesive is an acrylic adhesive and the masking substrate comprises polyethylene.

9. The method of claim 8, wherein the masking adhesive comprises at least one UV stabilizer.

10. An apparatus comprising:

an insulating glazing unit comprising two spaced-apart panes having a gap between them;

a photocatalytic thin film coating on a desired major surface of one of the panes, said desired major surface being an exterior surface facing away from said gap; and

a removable protective masking overlaying the photocatalytic thin film coating, said masking comprising a masking substrate and a masking adhesive, wherein the masking adhesive is in direct adhesive contact with the photocatalytic thin film coating.

11. The apparatus of claim 10, wherein the removable protective masking is a peelable masking, the masking adhesive having a higher level of adhesion to the masking substrate than to said coated major surface, such that the adhesive is adapted to adhere

preferentially to the masking substrate when the masking is peeled off said coated major surface.

12. The apparatus of claim 11, wherein the masking adhesive is an acrylic adhesive and the masking substrate comprises polyethylene.

5 13. The apparatus of claim 10, wherein the masking adhesive comprises at least one UV stabilizer.

14. The apparatus of claim 10, wherein the masking adhesive comprises at least one hindered amine.

10 15. The apparatus of claim 14, wherein the hindered amine comprises tetramethyl piperidine derivative.

16. The apparatus of claim 15, wherein the hindered amine is selected from the group consisting of:

the polycondensation product of 1-(2-hydroxyethyl)-2,2,6,6-tetramethyl-4-hydroxypiperidine and succinic acid;

15 the polycondensation product of 4,4'-hexamethylene-bis(amino-2,2,6,6-tetramethylpiperidine) and 2,4-dichloro-6-tert-octylamino-s-triazine;

the polycondensation product of 4,4'-hexamethylene-bis(amino-2,2,6,6-tetramethylpiperidine) and 2,4-dichloro-6-cyclohexylamino-s-triazine;

20 the polycondensation product of 4,4'-hexamethylene-bis(amino-2,2,6,6-tetramethylpiperidine) and 2,4-dichloro-6-morpholino-s-triazine;

poly[methyl 3-(2,2,6,6-tetramethylpiperidin-4-yloxy)propyl]siloxane;

bis(2,2,6,6-tetramethylpiperidin-4-yl) cyclohexylenedioxydimethylmalonate;

1,3,5-tris{N-cyclohexyl-N-[2-(2,2,6,6-tetramethylpiperazin-3-on-4-yl)ethyl] amino-s-triazine;

25 N,N',N'',N'''-tetrakis[4,6-bis(butyl-(2,2,6,6-tetramethylpiperidin-4-yl)amino)-s-triazin-2-yl]-1,10-diamino-4,7-diazadecane; and

the polycondensation product of 2,4-dichloro-6-(2,2,6,6-tetramethylpiperidin-4-yl)butylamino-s-triazine and 2,2'-ethylene-bis{[2,4-(2,2,6,6-tetramethylpiperidin-4-yl)butylamino-s-triazin-6-yl]aminotrimethyleneamino}.

30 17. The apparatus of claim 10, wherein the photocatalytic thin film coating comprises an active film comprising titania, said active film having a thickness of less than 100 angstroms.

18. The apparatus of claim 17, wherein the thickness of the active film is less than 75 angstroms.

19. The apparatus of claim 10, wherein the photocatalytic thin film coating comprises an active film comprising titania, the active film being deposited directly over
5 an amorphous film.

20. The apparatus of claim 19, wherein the amorphous film has a composition adapted to maintain a morphology that is at least substantially amorphous when subjected to glass tempering.

21. The apparatus of claim 10, wherein the photocatalytic thin film coating
10 comprises an active film comprising titania, the active film being deposited directly over an underlying film having a thickness of less than 200 angstroms.

22. The apparatus of claim 21, wherein the thickness of the underlying film is less than 100 angstroms.

23. An apparatus comprising:
15 an insulating glazing unit comprising two spaced-apart panes having a gap between them;

a photocatalytic thin film coating on a desired major surface of one of the panes, said desired major surface being an exterior surface facing away from said gap; and

a removable protective masking overlaying the photocatalytic thin film coating,
20 said masking comprising a masking substrate and a masking adhesive, wherein the masking adhesive is in direct adhesive contact with the photocatalytic thin film coating, and wherein the removable protective masking is a peelable masking, the masking adhesive having a higher level of adhesion to the masking substrate than to said coated major surface, such that the adhesive is adapted to adhere preferentially to the masking
25 substrate when the masking is peeled off said coated major surface.

24. The apparatus of claim 23, wherein the masking adhesive is provided with at least one UV stabilizer.

25. The apparatus of claim 23, wherein the masking adhesive comprises at least one hindered amine.

30 26. The apparatus of claim 23, wherein the insulating glazing unit is further provided with a masked #4 major surface, the masked #4 surface carrying a second peelable masking.

27. The apparatus of claim 23, wherein the masking adhesive is an acrylic adhesive and the masking substrate comprises polyethylene.

1/12

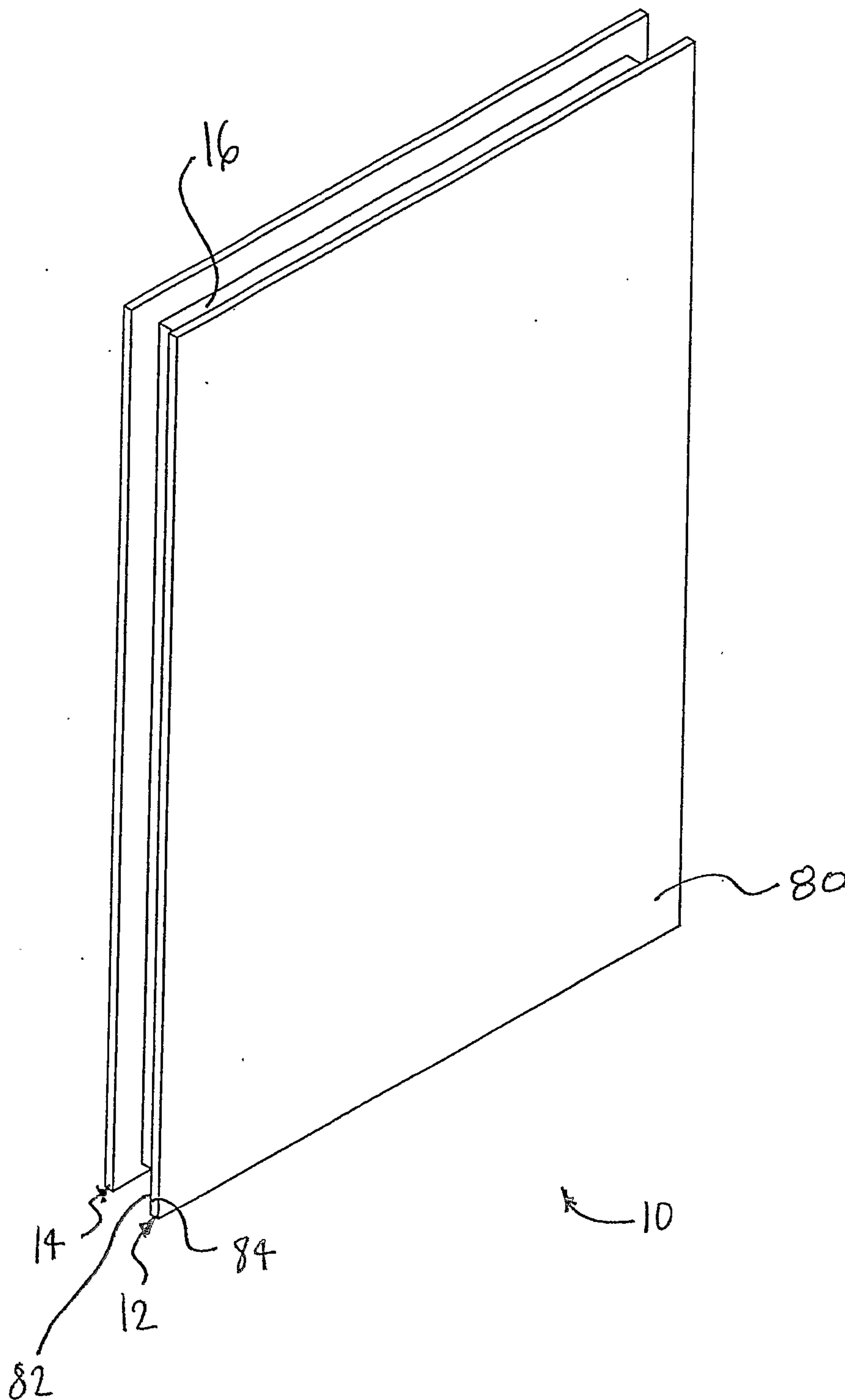

FIG. 1

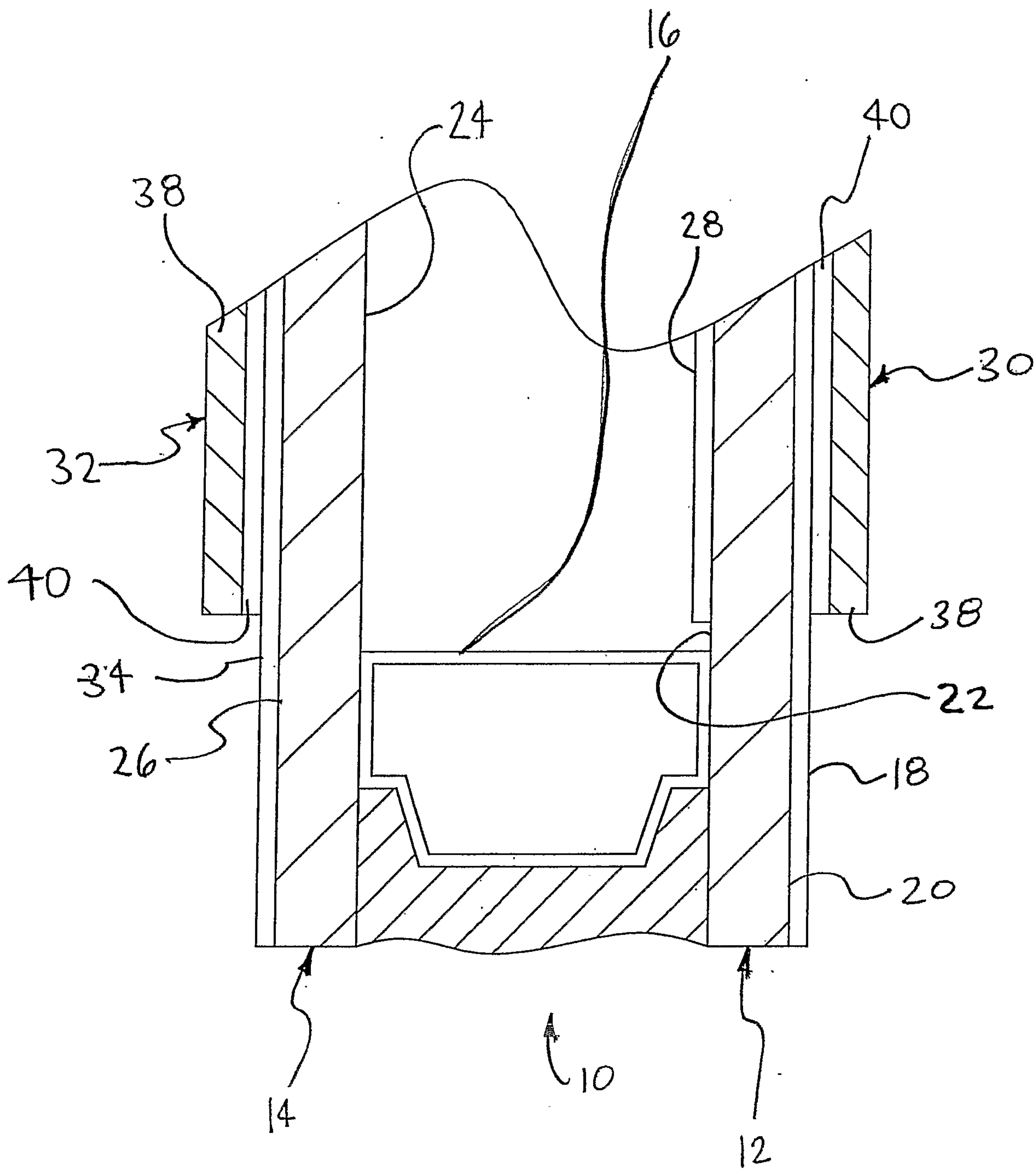

FIG. 2

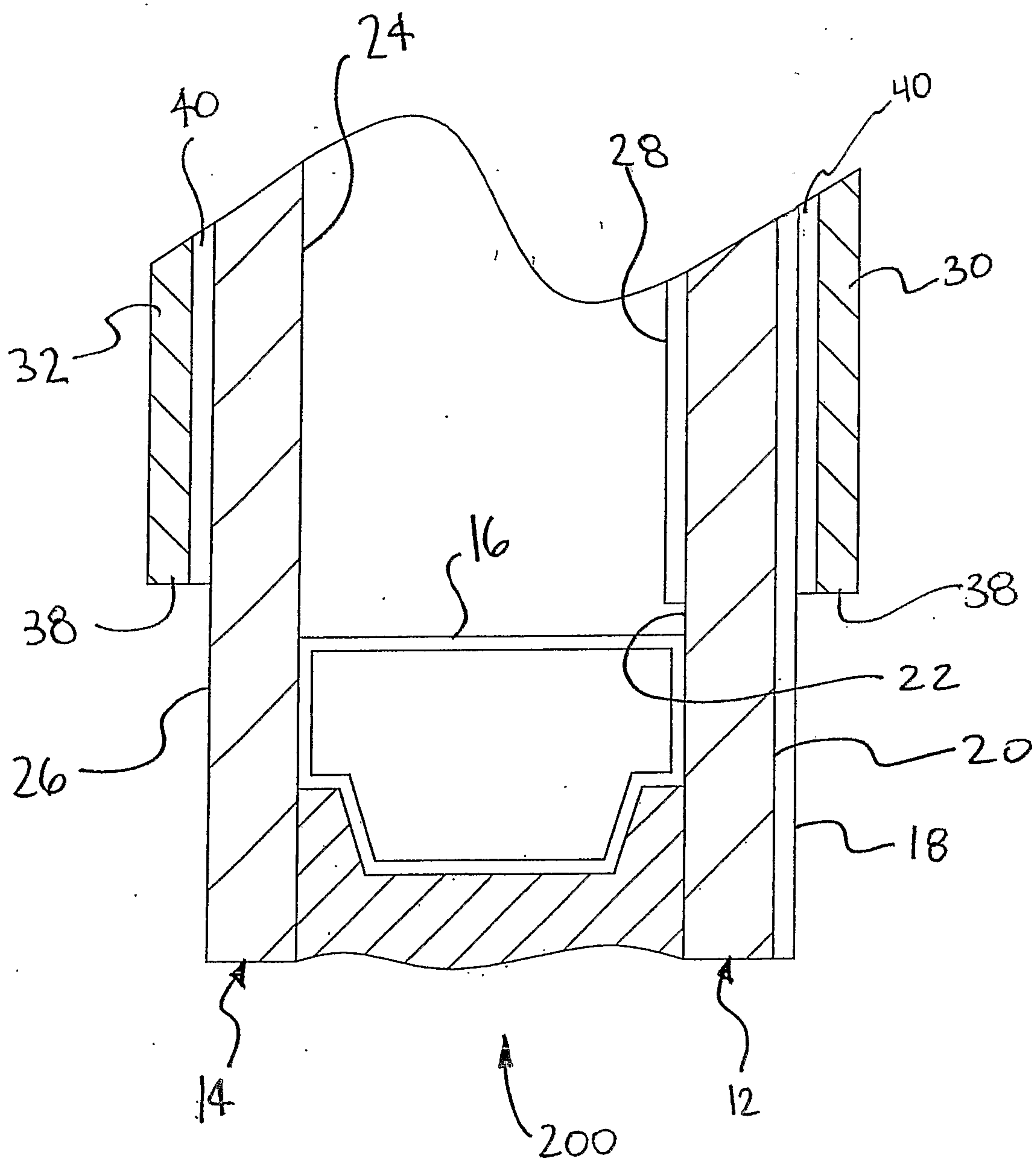

FIG. 3

4/12

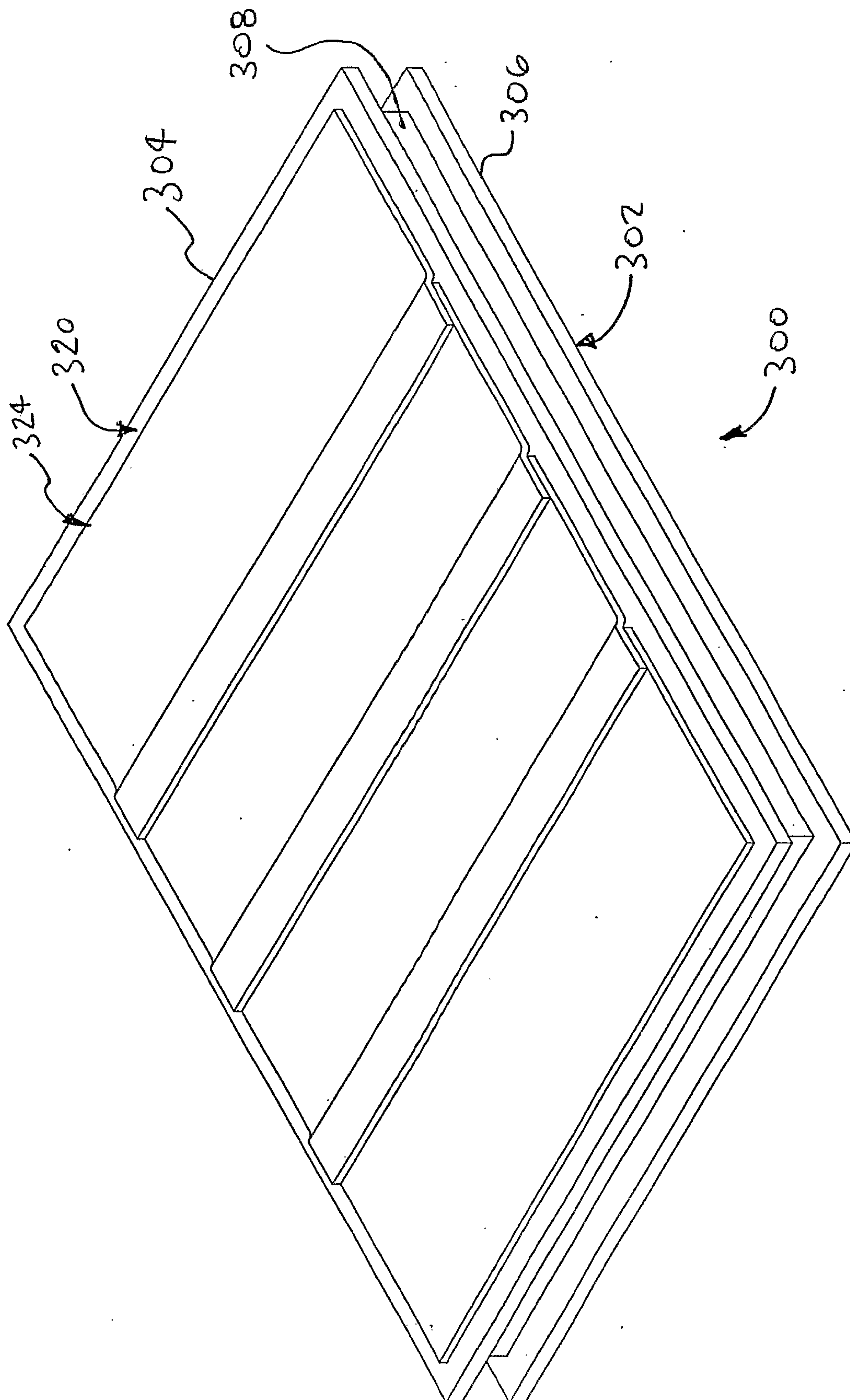

FIG. 4

5/12

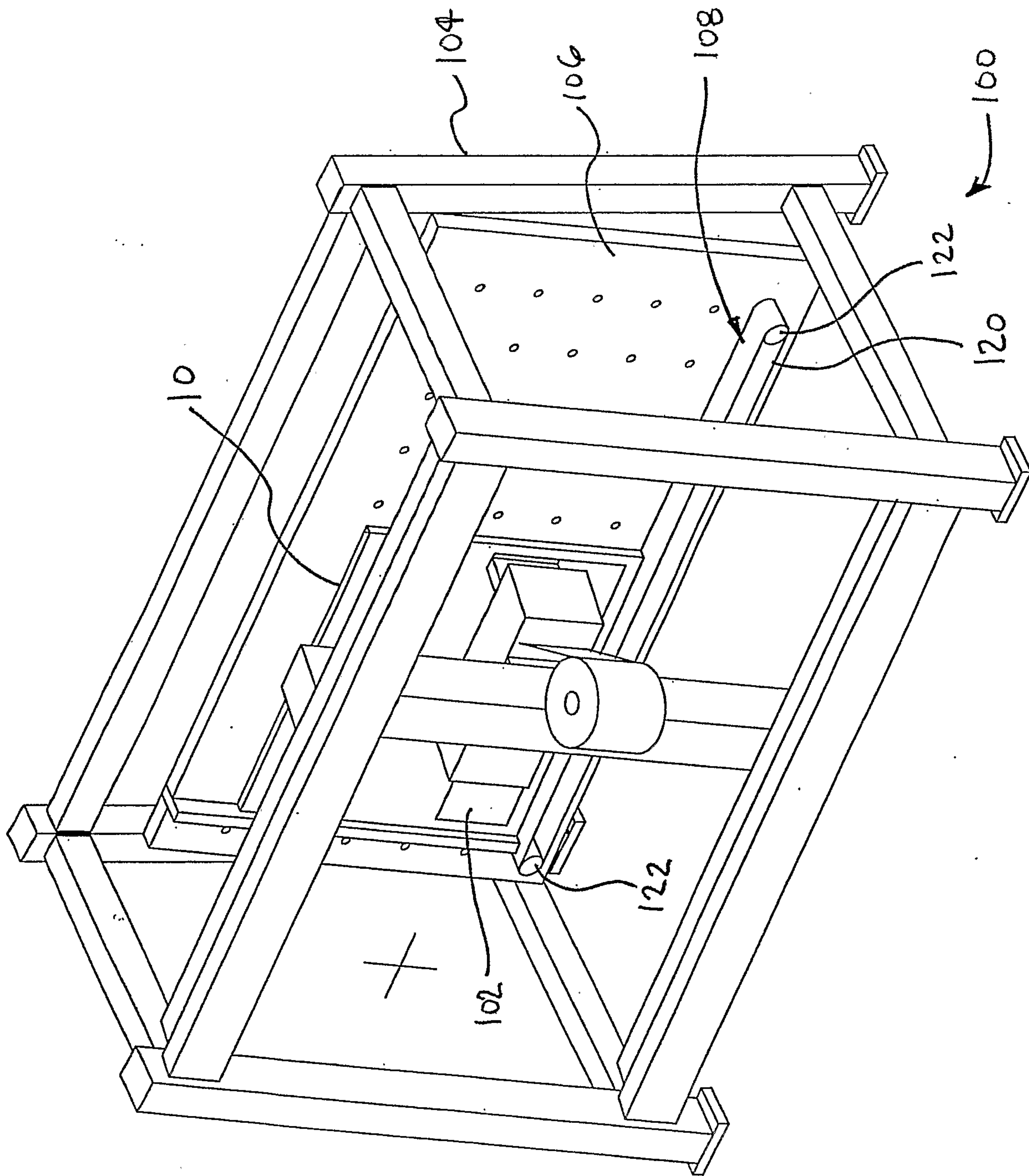

FIG. 5

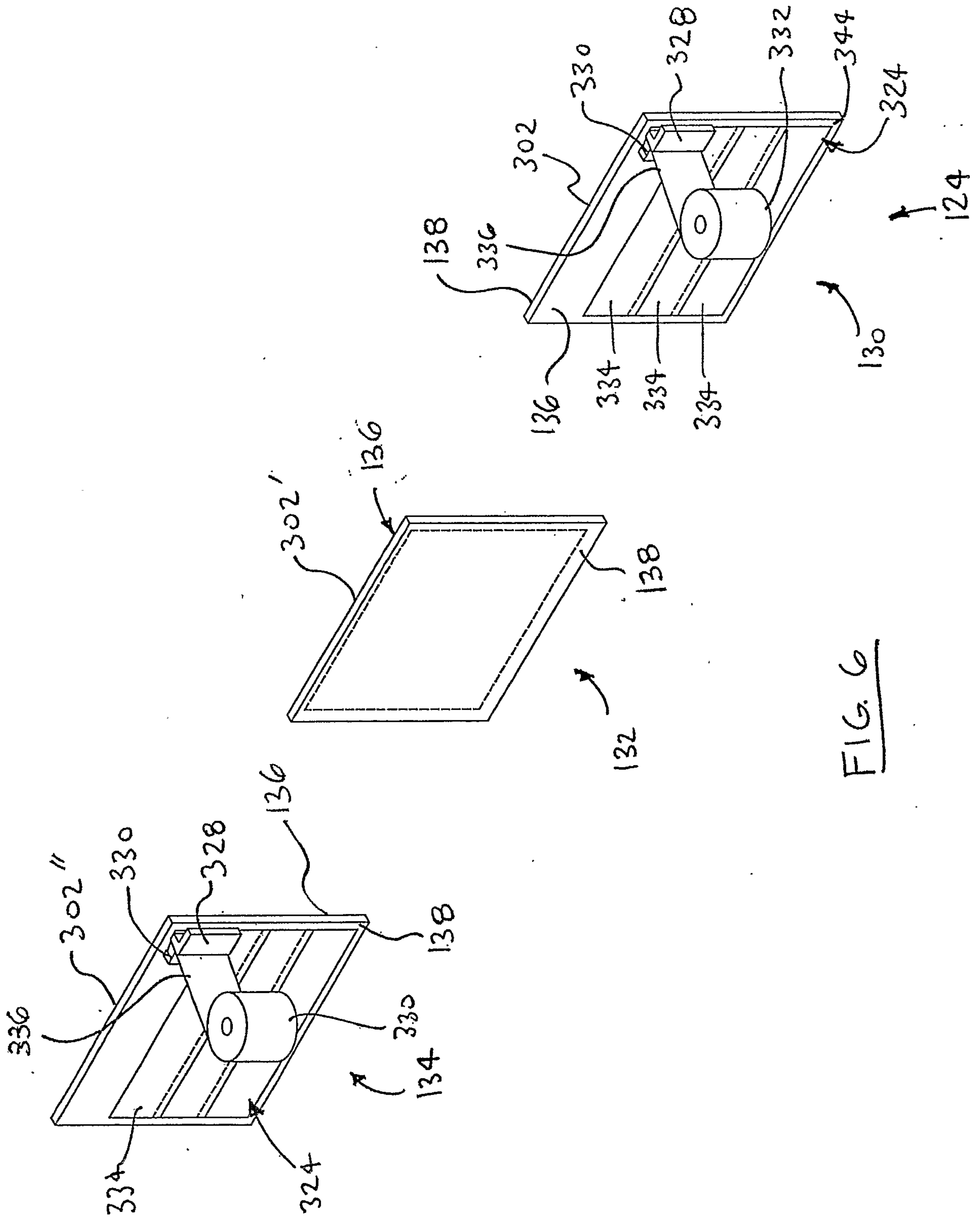

FIG. 6

7/12

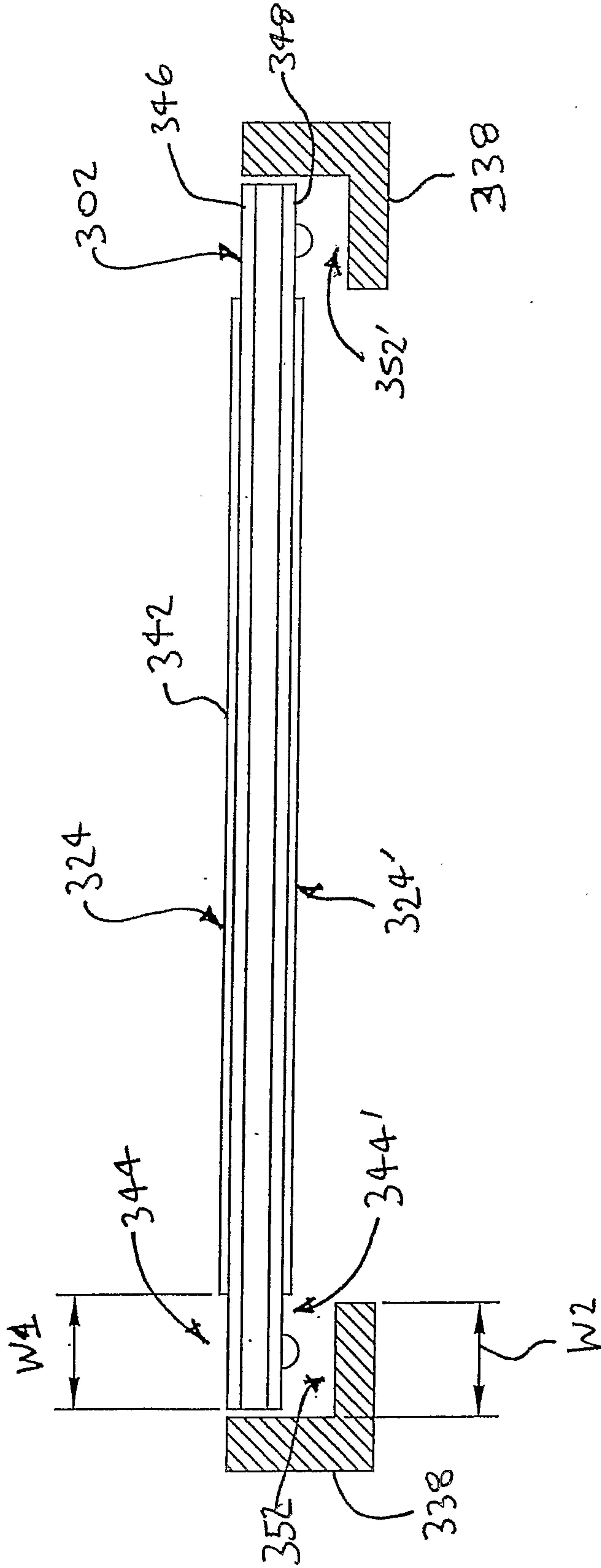

FIG. 7

8/12

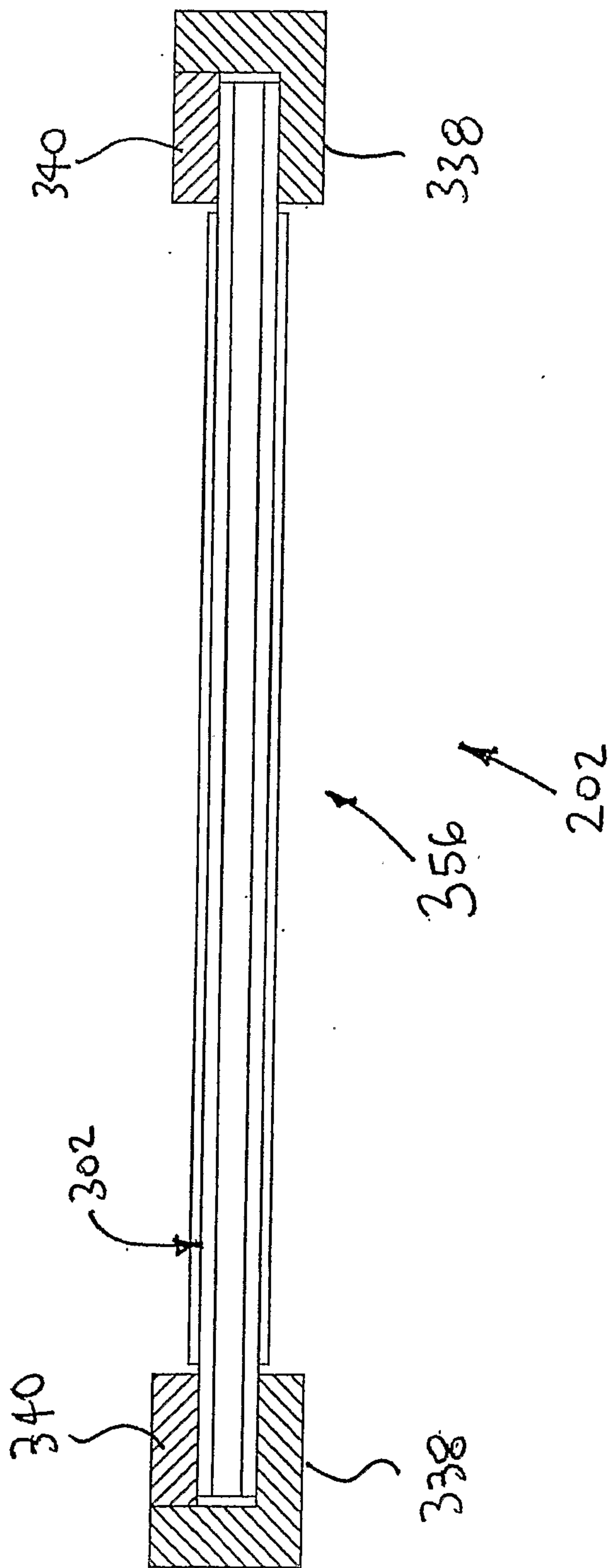

FIG. 8

9/12

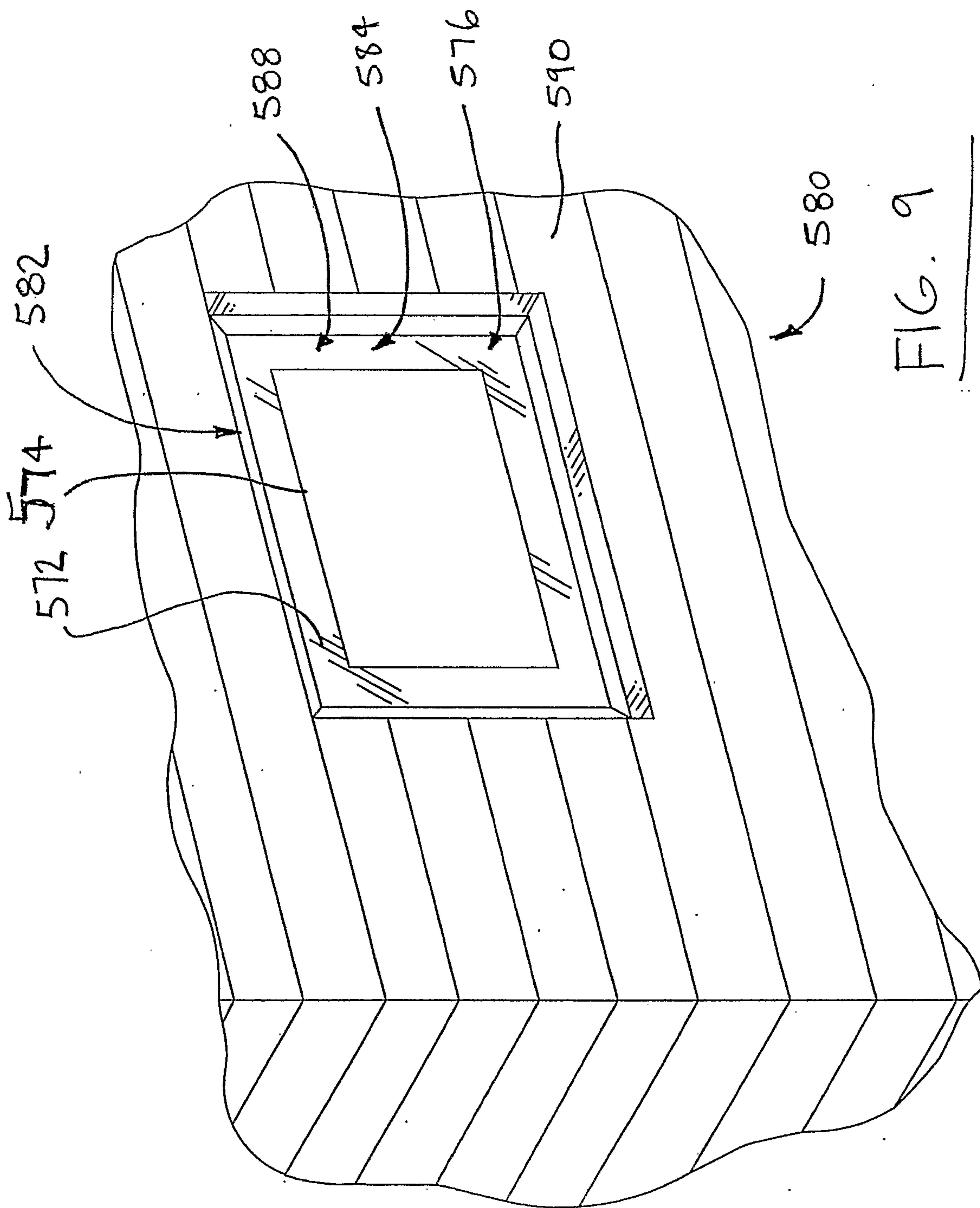

FIG. 9

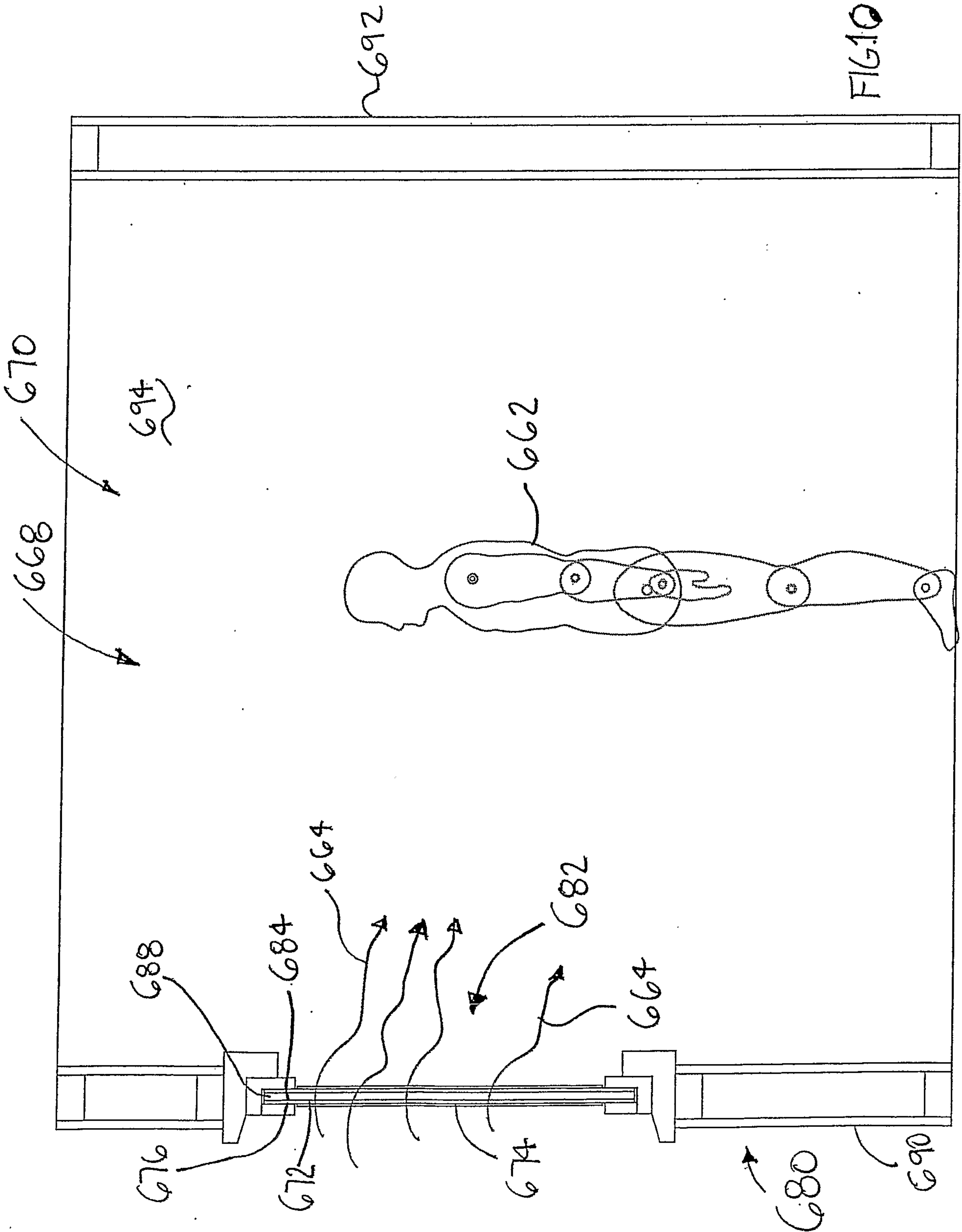
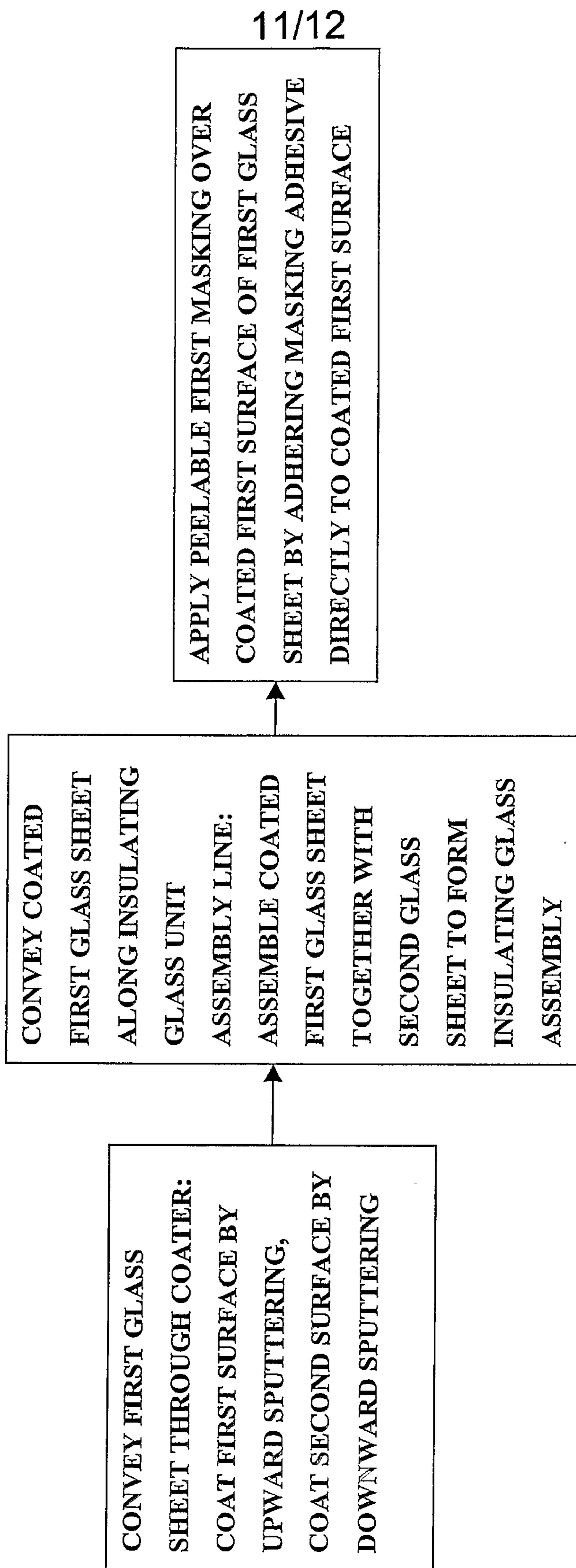

FIG. 11



12/12

Figure 12

