



US 20110015721A1

(19) **United States**  
(12) **Patent Application Publication**  
**Tseng et al.**

(10) **Pub. No.: US 2011/0015721 A1**  
(43) **Pub. Date: Jan. 20, 2011**

(54) **INTRALUMINAL STENT**

No. 09/623,347, filed on Nov. 15, 2000, now Pat. No. 6,730,117, filed as application No. PCT/US99/04694 on Mar. 4, 1999.

(75) Inventors: **David Tseng**, Santa Rosa, CA (US);  
**Ellen Golds**, Hastings-on-Hudson,  
NY (US); **Bruce Parsons**, Pompano  
Beach, FL (US)

(60) Provisional application No. 60/076,946, filed on Mar. 5, 1998.

**Publication Classification**

Correspondence Address:  
**VIDAS, ARRETT & STEINKRAUS, P.A.**  
**SUITE 400, 6640 SHADY OAK ROAD**  
**EDEN PRAIRIE, MN 55344 (US)**

(51) **Int. Cl.**  
**A61F 2/82** (2006.01)  
(52) **U.S. Cl.** ..... **623/1.16; 623/1.15**  
(57) **ABSTRACT**

(73) Assignee: **BOSTON SCIENTIFIC**  
**SCIMED, INC.**, Maple Grove, MN  
(US)

An intraluminal stent made of a zig-zag or sinusoidal member defining a successive series of struts connected by apex sections and formed into a series of axially displaced hoop members wherein at least one of the hoop members has at least 5 one strut connected to a strut of an adjacent hoop. The connected struts may be connected by spot welding, continuous welding, or suturing, for example, or by a bridging member connected to each strut, and may be spaced along the length of the stent in a pattern to form a connective spine. The number of zigs of the zig-zag member in each hoop member may be varied, as can the zig length. A plurality of 10 connective spines may also be included.

(21) Appl. No.: **12/888,810**

(22) Filed: **Sep. 23, 2010**

**Related U.S. Application Data**

(63) Continuation of application No. 10/747,848, filed on Dec. 29, 2003, which is a continuation of application

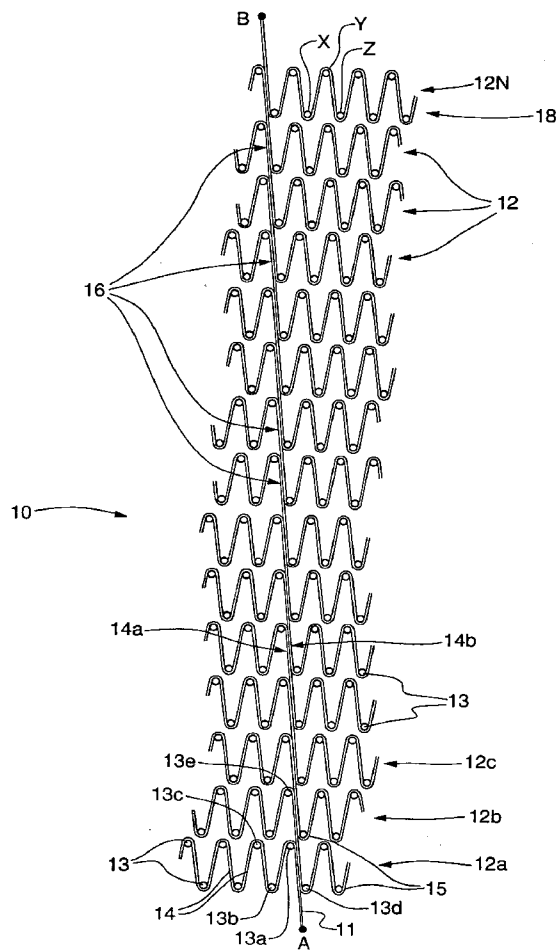

Fig. 1

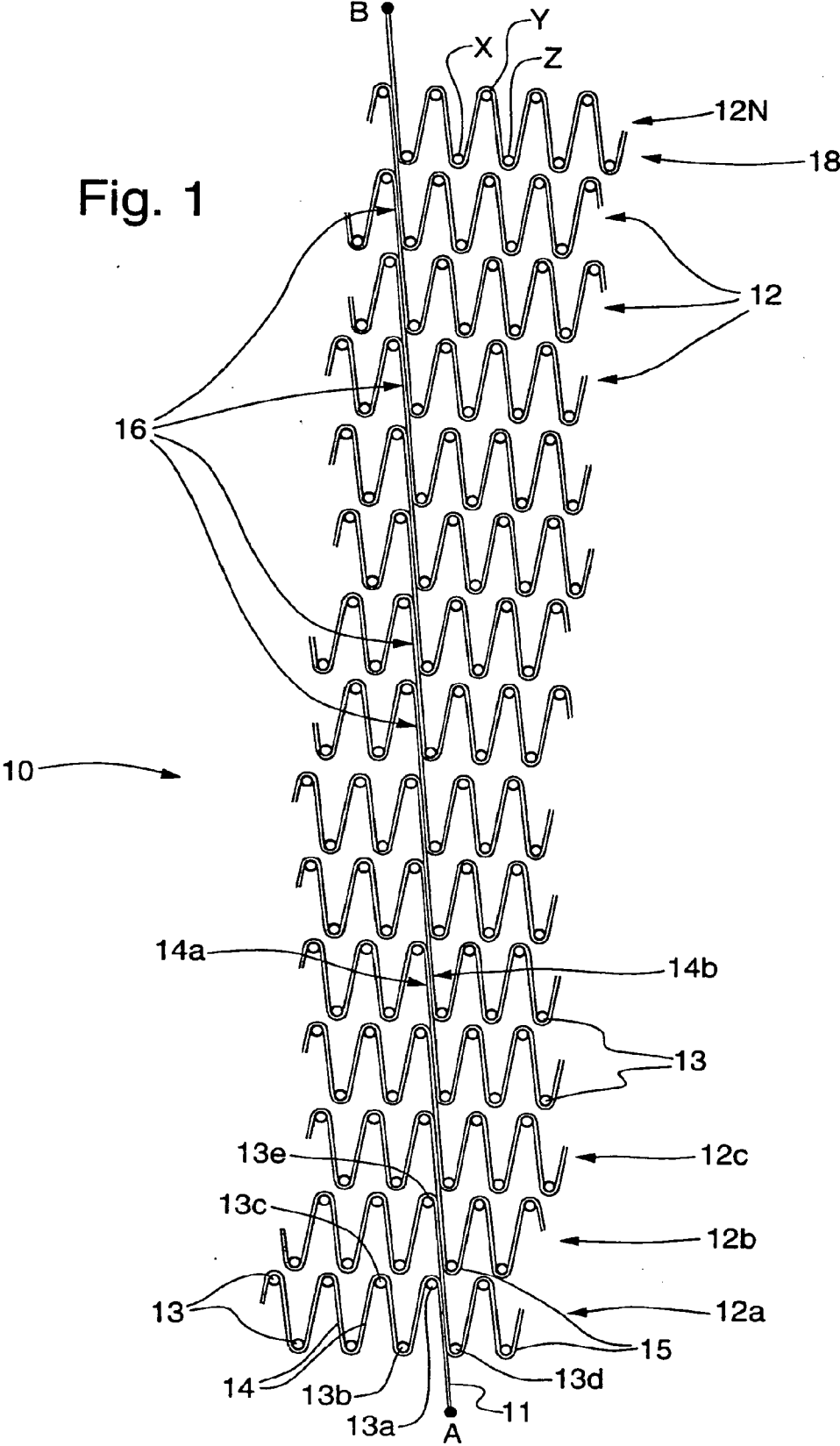
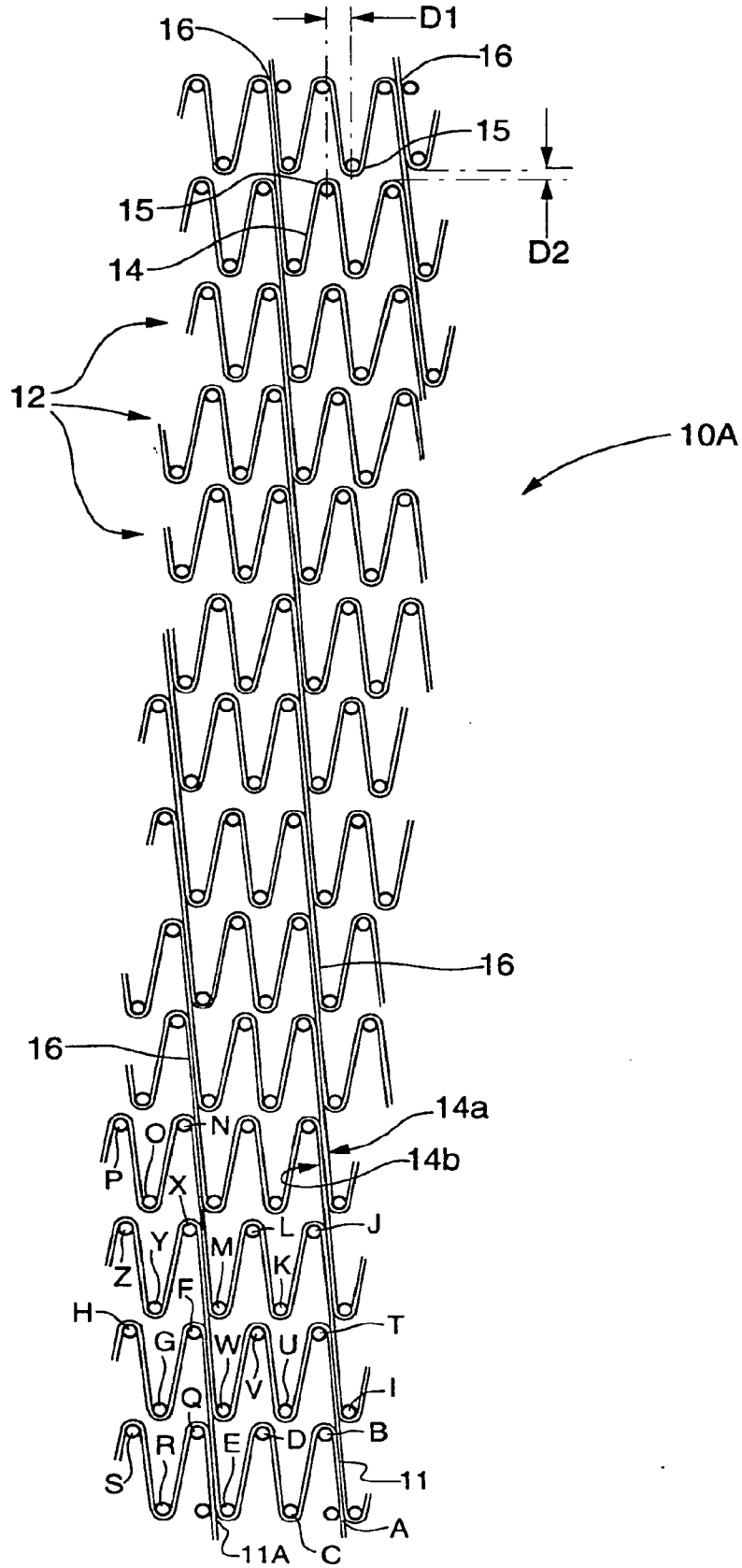

Fig. 2



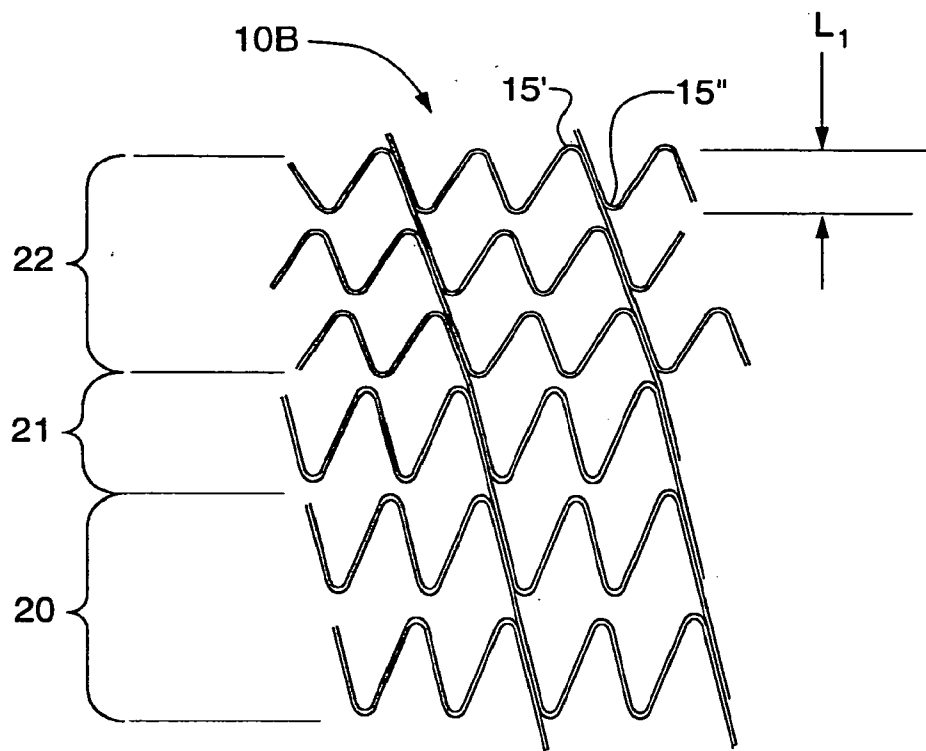

Fig. 3

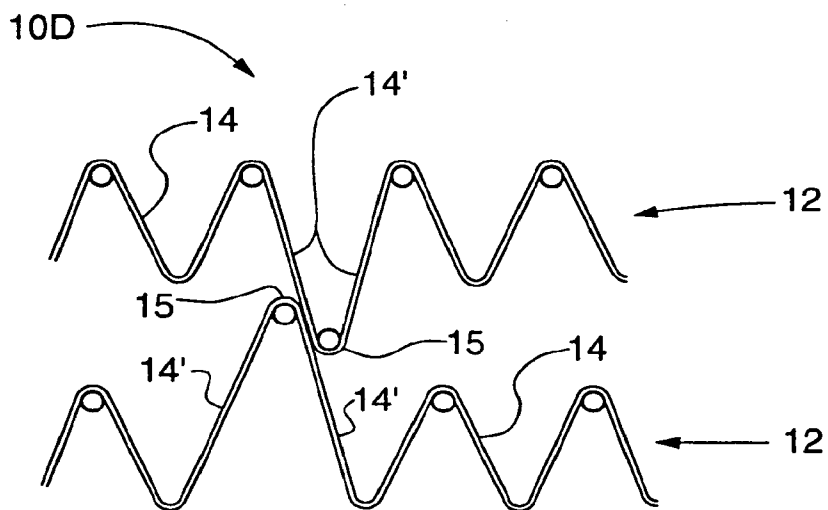

Fig. 9

Fig. 4

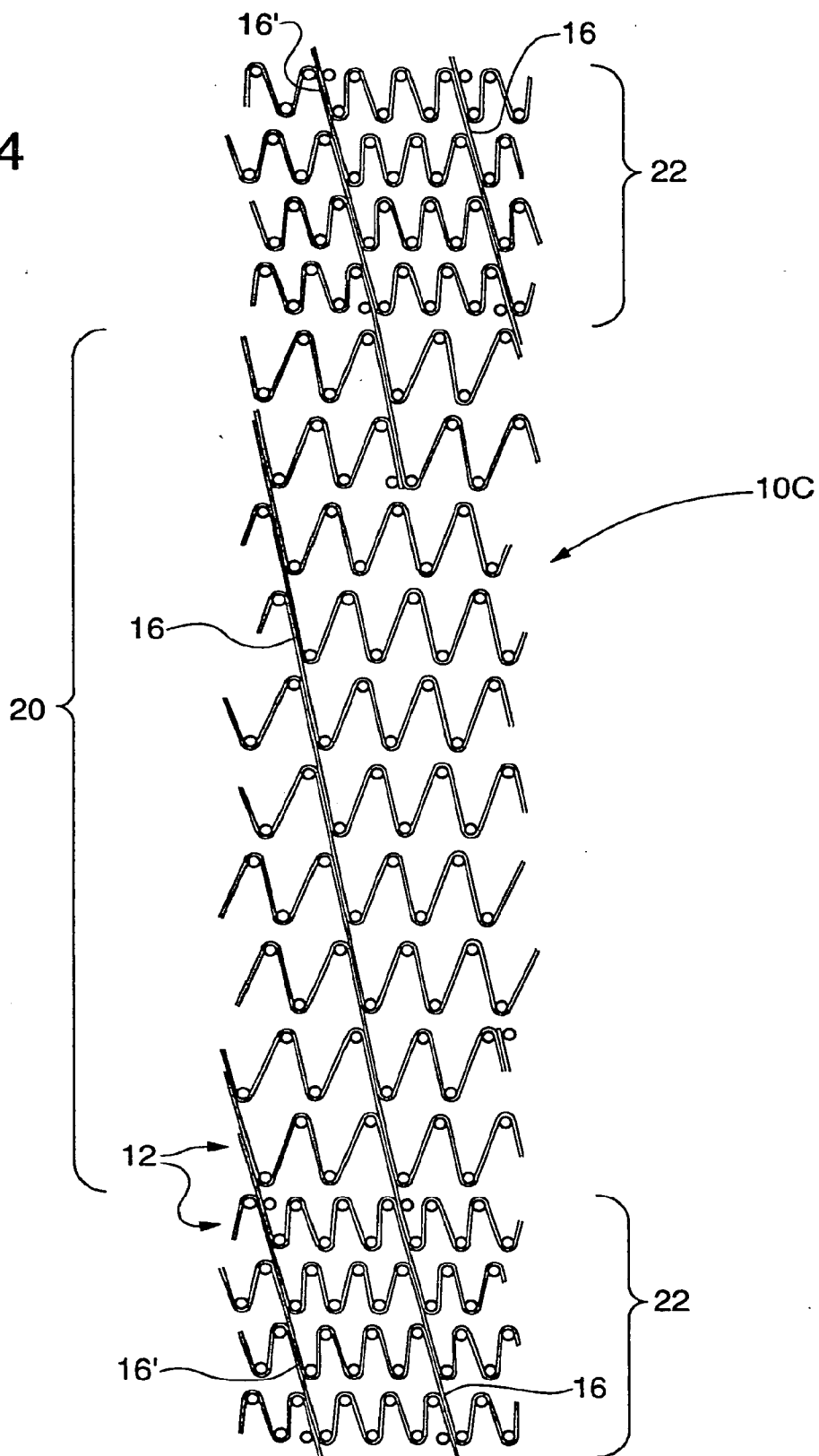
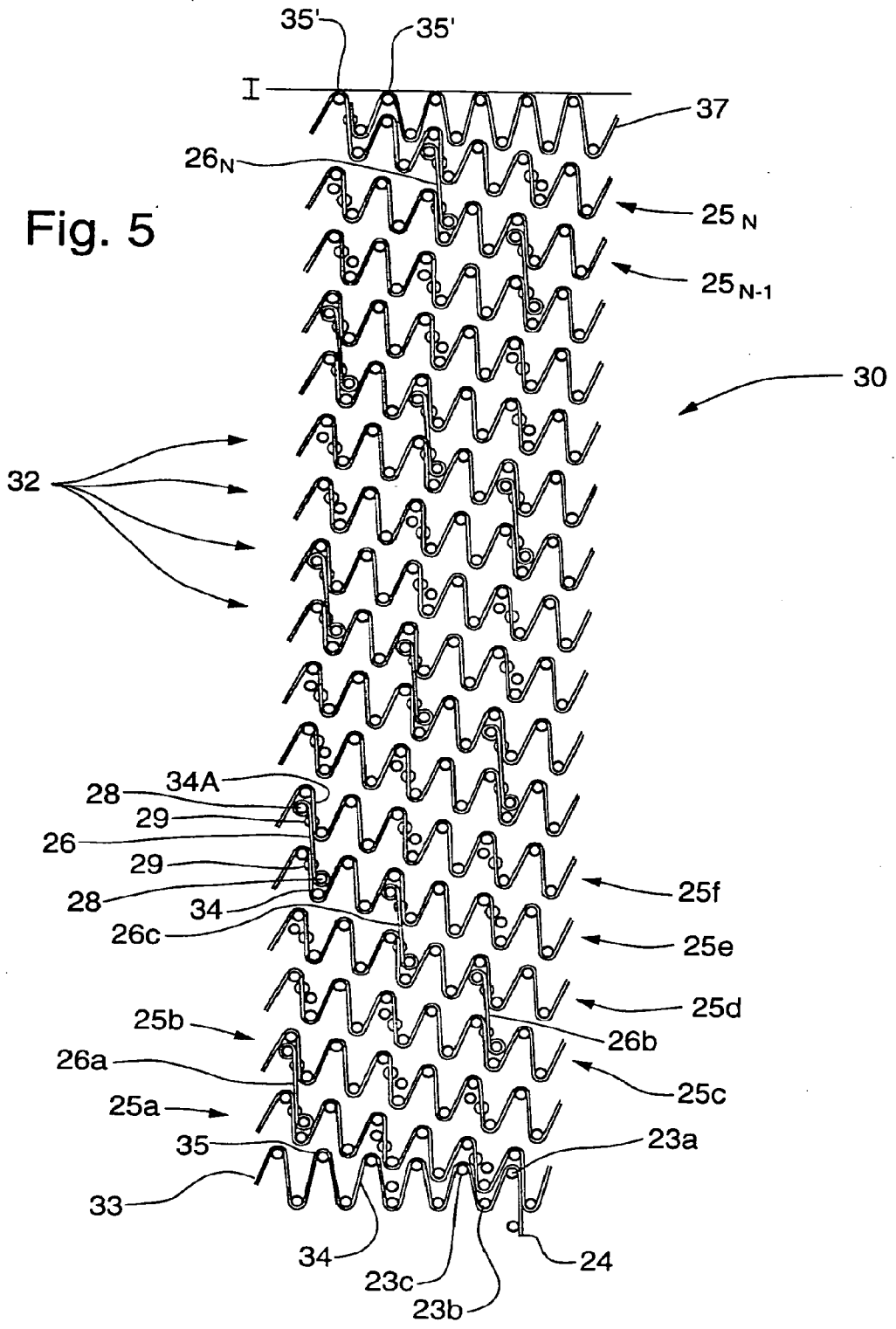
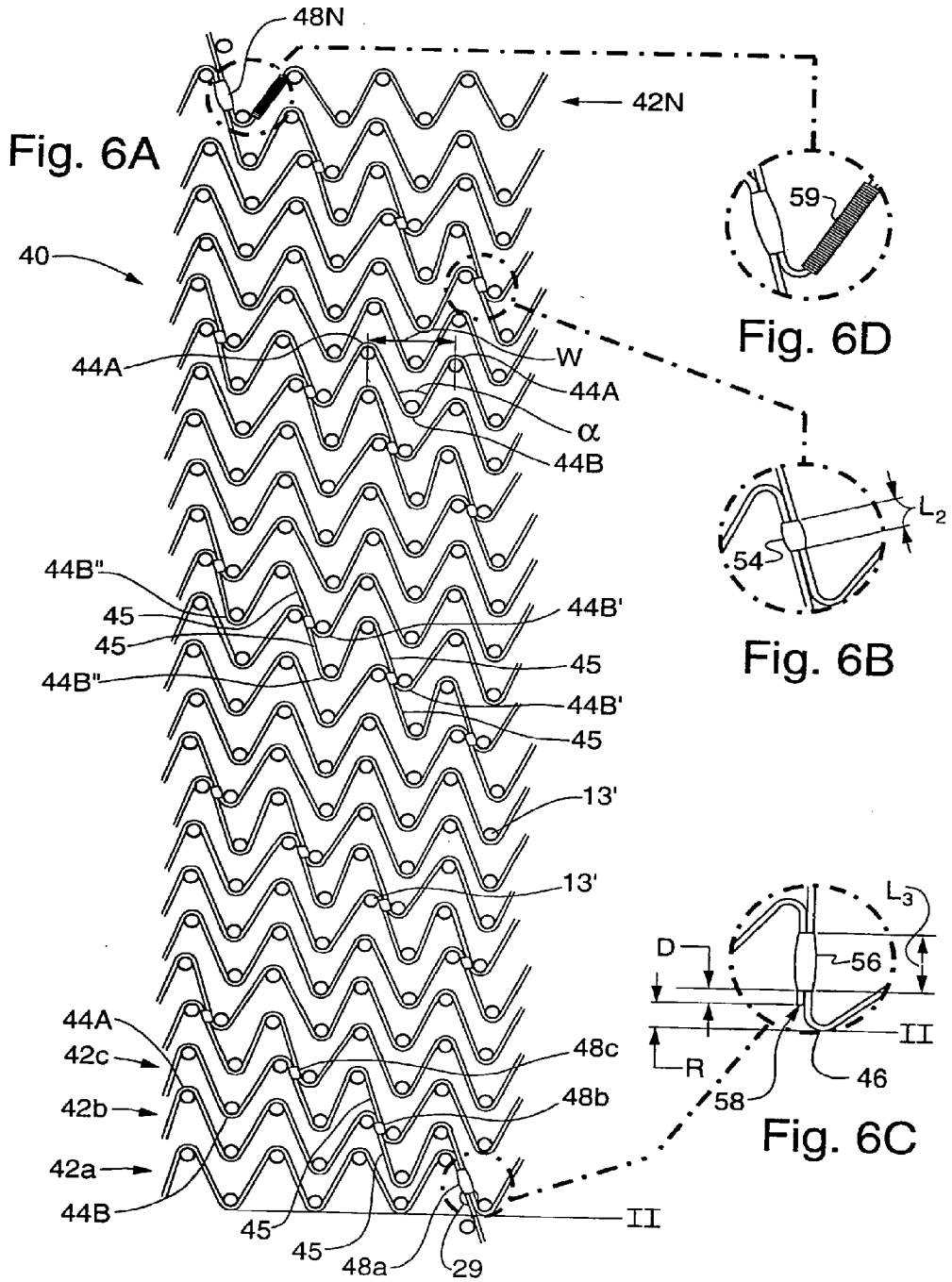

Fig. 5





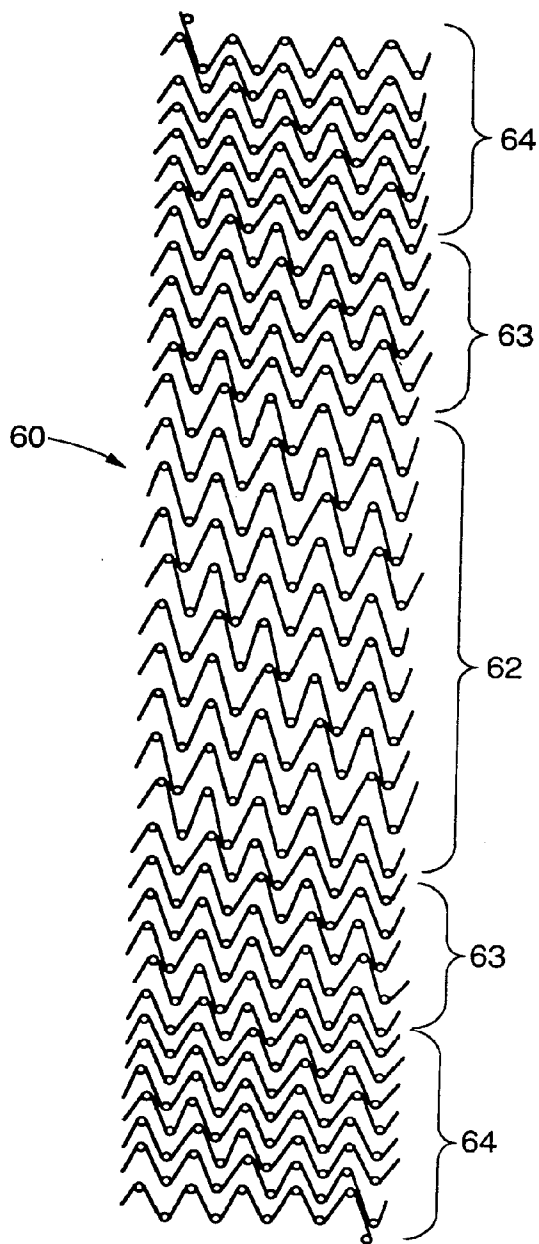

Fig. 6F

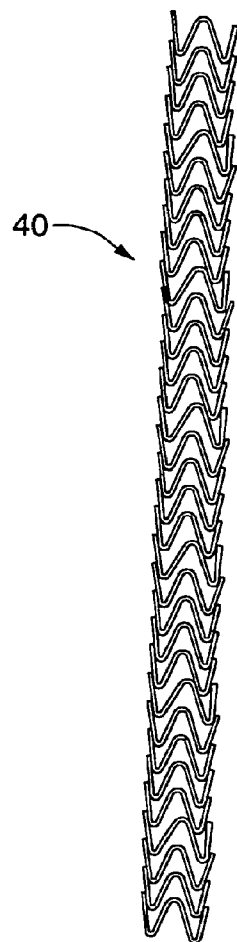

Fig. 6E



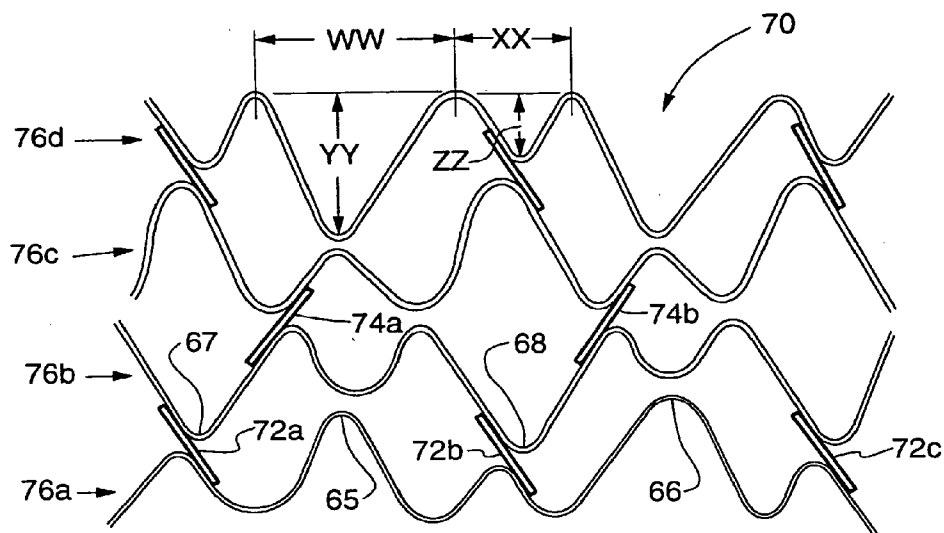

Fig. 7

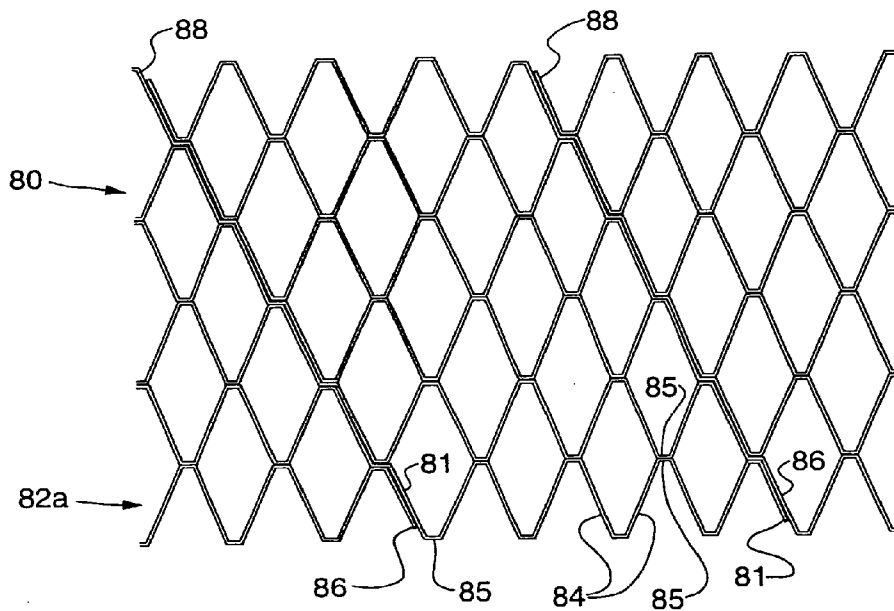

Fig. 8

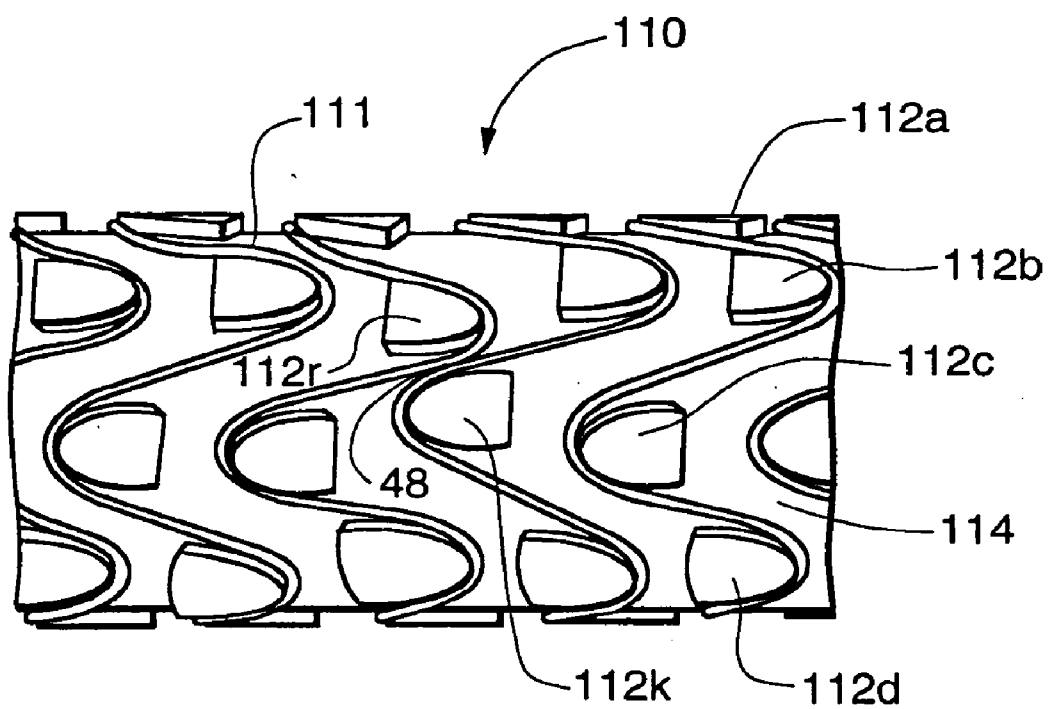

Fig. 10

**INTRALUMINAL STENT**

**CROSS-REFERENCE TO RELATED APPLICATIONS**

[0001] This application is a continuation of U.S. patent application Ser. No. 10/747,848, filed Dec. 29, 2003, which is a continuation of U.S. patent application Ser. No. 09/623,347, filed Nov. 15, 2000, which is a U.S. national phase application from International Patent Application PCT/US99/04694, international filing date Mar. 4, 1999, which claims priority based on U.S. Provisional Application Ser. No. 60/076,946, filed Mar. 5, 1998, which is hereby incorporated by reference.

**FIELD OF INVENTION**

[0002] This invention relates generally to intraluminal prostheses, and more particularly to intraluminal stents comprised of zig-zag or sinusoidal wire hoops.

**BACKGROUND OF THE INVENTION**

[0003] A common method of treating vessel diseases such as stenoses, strictures, thrombosis, or aneurysms involves placing a stent into the affected vessel. Among other advantages, stents prevent vessels from collapsing, reinforce vessel walls, increase cross sectional area (and thereby volumetric flow), and restore or maintain healthy blood flow. Many stents have been developed, and the prior art includes a wide variety of types and methods for their manufacture.

**SUMMARY OF THE INVENTION**

[0004] The present invention is a generally cylindrical intraluminal stent including a plurality of circumferential wire hoops disposed in succession along the axis of the stent. Each of the hoops has zig-zag or sinusoidal members defined by a successive series of struts connected by apex sections alternately pointing in opposite axial directions. The struts may be substantially straight sections connected to essentially sharp apex sections in a jagged zig-zag configuration, or the apex sections may be more rounded so that together with the struts there is formed a sinusoidal configuration. The lengths of these struts may be uniform throughout the stent or may vary alternately or continuously. Likewise, the angles or radii of curvature and configurations of the apices may be uniform or may vary. To provide mechanical integrity, selected portions of the hoops may be secured against relative axial movement, such as by spot welding overlying straight sections either in an individual hoop or in adjacent hoops. Such connections may also be made with bridging members aligned with straight sections in adjacent hoops.

[0005] These connections (with or without intervening bridging members) may be disposed in one or more linear or helical paths along the length of the stent, thus acting as stabilizing spines. Alternatively, these connections may be disposed in other preselected patterns, such as alternating around the circumference of the stent, to impart stability at these preselected locations.

**BRIEF DESCRIPTION OF THE DRAWINGS**

[0006] The figures provided are for illustrative purposes, and are not drawn to scale. The expanded relative dimensions allow a better understanding of the present invention. One skilled in the art will readily determine actual dimensions based on information supplied in this specification.

[0007] FIG. 1 is a diagrammatic view of an exemplary embodiment of a stent according to this invention, where the tubular stent is shown opened along a line parallel to the stent axis, and flattened; also shown are mandrel pins used in forming the stent.

[0008] FIG. 2 is a diagrammatic view of another exemplary embodiment of a stent according to this invention having multiple spines and axial and circumferential offsets between facing apex sections, where the tubular stent is shown opened along a line parallel to the stent axis, and flattened; also shown are mandrel pins used in forming the stent.

[0009] FIG. 3 is a partial diagrammatic view of another exemplary embodiment of a stent according to this invention having a plurality of longitudinal sections, the middle section having a different number of spines, a different number of zigs, and a different zig length than the end sections, where the tubular stent is shown opened along a line parallel to the stent axis, and flattened.

[0010] FIG. 4 is a diagrammatic view of another exemplary embodiment of a stent according to this invention having end portions with different zig characteristics relative to a center portion, where the tubular stent is shown opened along a line parallel to the stent axis, and flattened; also shown are mandrel pins used in forming the stent.

[0011] FIG. 5 is a diagrammatic view of another exemplary embodiment of a stent according to this invention having connecting members that include separate bridging members, where the tubular stent is shown opened along a line parallel to the stent axis, and flattened; also shown are mandrel pins and weld holes used in forming the stent.

[0012] FIG. 6A is a diagrammatic view of an exemplary embodiment of a stent according to this invention having interdigitated zigs, where the tubular stent is shown opened along a line parallel to the stent axis, and flattened.

[0013] FIGS. 6B-6D are diagrammatic views of enlarged portions of the stent of FIG. 6A, showing an exemplary end weld, and exemplary middle weld, and an exemplary radio-opaque marker, respectively.

[0014] FIG. 6E is a diagrammatic view of an exemplary embodiment of stent 6A, where the stent is shown in its normal tubular configuration.

[0015] FIG. 6F is a diagrammatic view of an exemplary embodiment of a stent according to this invention having interdigitated zigs and a plurality of longitudinal sections of different zig configurations, where the tubular stent is shown opened along a line parallel to the stent axis, and flattened.

[0016] FIG. 7 is a partial side view of an exemplary embodiment of a stent according to this invention having alternating zig lengths, where the tubular stent is shown opened along a line parallel to the stent axis, and flattened.

[0017] FIG. 8 is a partial diagrammatic view of another exemplary embodiment of a stent according to this invention having straight-edged apex sections, where the tubular stent is shown opened along a line parallel to the stent axis, and flattened.

[0018] FIG. 9 is a partial diagrammatic view of another exemplary embodiment of a stent according to this invention having connecting members formed by elongated struts, where the tubular stent is shown opened along a line parallel to the stent axis, and flattened; also shown are mandrel pins used in forming the stent.

[0019] FIG. 10 is a partial diagrammatic view of the stent shown in FIG. 6A mounted on a mandrel during fabrication of the stent.

#### DETAILED DESCRIPTION OF THE INVENTION

[0020] FIG. 1 illustrates an exemplary stent 10 according to the present invention. Stent 10 is generally cylindrical and adapted to be inserted into a lumen. Stent 10 has been cut longitudinally and laid flat for purposes of illustration. Stent 10 is formed by winding a continuous filament such as a wire 11 into a zig-zag or sinusoidal configuration and into a plurality of circumferential hoop members 12a, 12b, 12c disposed in succession along the axis of stent 10. Wire 11 is preferably nitinol wire, which provides a stent that auto-expands by shape memory, but it may be made of any suitable material, including stainless steel and thermoplastic polymers. Thus, the stent may be capable of deployment by shape memory auto-expansion, thermal auto-expansion or balloon expansion, as are well-known in the art. The width of the wire affects the radial force exerted by stent 10. Increasing the diameter of wire 11 increases the radial force.

[0021] For convenience, the configuration of the wire is referred to throughout having a “zig-zag” shape with zigs or zig lengths. As so used herein, however, the term “zig-zag” encompasses not only a jagged zig-zag shape where the apex sections are relatively sharp and the struts are substantially straight, but also a sinusoidal shape where the apex sections are rounded and, together with the struts, form a shape resembling a sine wave having an amplitude (zig length) and a period or wavelength (zig width). Similarly, although the apex sections may be referred to as defining a zig angle, the angle may be more rounded such that lesser and greater angles may be more envisioned as smaller and larger radii of curvature, respectively. Of course, the actual wire configuration may have a shape intermediate the jagged zig-zag and rounded sine wave shapes, or may be even more rounded than a sine wave, and the apex sections may in fact have a truncated, straight edge rather than a rounded shape or sharp angle, as described herein later.

[0022] To form stent 10, wire 11 is wound around pins 13 on a mandrel (not shown). The mandrel is typically cylindrical (although other shapes may be used as necessary to form stents of varying shapes) and of a diameter determined by the diameter of the vessel into which stent 10 is to be inserted. Typically, the mandrel diameter, and hence the intended diameter of stent 10, is slightly larger (for example, by one millimeter) than the diameter of the vessel. The length of stent 10 is also determined by the particular application.

[0023] Stent 10 is formed by winding wire 11 around pins 13 beginning at point A in FIG. 1. Wire 11 is extended to and around pins 13a, 13b, 13c and so forth. In this manner, zig-zag members are formed and defined by a successive series of substantially straight sections (struts) 14 connected by apex sections 15 alternately pointing in opposite axial directions. The winding continues in this manner around the mandrel until a first hoop member 12a is completed by winding wire 11 once around the circumference of the mandrel. Hoop member 12a as shown in FIG. 1 has a circumference lying in a plane substantially perpendicular to the axis of the mandrel (and hence of stent 10). Once a first hoop member 12a is formed, wire 11 is extended from pin 13d to and around pin 13e. Winding then continues as before to form a second hoop member 12b adjacent to first hoop member 12a. By forming hoop members in this manner, adjacent hoops 12a and 12b are

connected by the portion of wire 11 extending between first hoop member 12a and second hoop member 12b. At the completion of the second hoop member 12b, wire 11 is again extended to the third hoop member 12c, which is wound as before, and so forth until the desired number N of hoop members 12 are formed along the length of stent 10. Thus, as shown in FIG. 1, the winding extends in a series of hoops between hoops 12a and hoop 12N, with the wire beginning at point A and ending at point B. After completion of winding, wire 11 is typically cut so that the wire terminates short of points A and B, generally terminating within the first hoop 12a and last hoop 12N, respectively, as described with reference to FIG. 6C herein later.

[0024] Stent 10 is removed from the mandrel and pins 13a, 13b, 13c, etc., prior to use. In the illustrated embodiment, each hoop member 12 has one pair of aligned, adjacent struts 14a and 14b. According to one embodiment of the present invention, aligned, adjacent struts 14a and 14b of the same hoop are welded together. Such welding may be spot welding along the length of aligned, adjacent struts 14a and 14b, or it may be a continuous weld. In either case, a welded, connective spine 16 is formed along the perimeter of stent 10. Connective spine 16 typically winds around the circumference of stent 10 in an offset helical fashion (the embodiment shown flat in FIG. 1 being cylindrical or tubular in actual use). Connective spine 16 provides strength and stability to stent 10 while preserving the flexibility of stent 10. During insertion of stent 10 into a vessel (described below), connective spine 16 renders stent 10 easier to push through a catheter. As an alternative to welding, connective spine 16 may be formed by connecting aligned, adjacent struts 14a and 14b according to any other suitable attachment means, including without limitation, tying, suturing, gluing, and stapling, with the glue or sutures being absorbable or non-absorbable, and including the use of polymer-containing connections.

[0025] When stent 10 comprises thermally expandable nitinol, stent 10 is annealed before removal from the mandrel and pins 13a, 13b, 13c, etc., at an annealing temperature for about one hour and then allowed to cool. This annealing temperature is desirably on the order of about 500° C., although any temperature sufficient to effect annealing of stent 10 will suffice. During annealing, it may be necessary to secure the nitinol wire to the mandrel by wrapping bailing wire, a thicker gauge and different material than the nitinol, around the stent on the mandrel. Such annealing of nitinol wire imparts a memory to the nitinol, such that stent 10 will “remember” its annealed shape and return to it after subsequent reconfiguration. This is a known property of nitinol, which has two distinct temperature-dependent phases, martensite and austenite. Below a certain temperature (the martensite transition temperature), nitinol is martensitic; above a certain temperature (the austenite transition temperature), it is austenitic. It is in the austenitic phase that nitinol remembers its annealed configuration.

[0026] After annealing, stent 10 is removed from the mandrel on which it is wound to compress stent 10 into a configuration for introduction to a body passageway. Then, it is cooled to below its martensitic transition temperature. In this phase, nitinol is malleable and has virtually no resiliency. Thus, it can be easily compressed. Stent 10 can be easily returned to its annealed shape by heating it to a temperature above its austenite transition temperature. Above this temperature, the stent resumes its annealed configuration.

[0027] In its annealed configuration, stent **10** has a first diameter. This is a relatively large diameter that is the intended final diameter of stent **10**. In order to be inserted into a body vessel, stent **10** must be compressed such that it may be inserted into a catheter. As indicated above, with a nitinol stent, this is accomplished by cooling stent **10** to below its martensite transition temperature at which temperature stent **10** is malleable and less resilient. Stent **10** can then be easily compressed into a second, relatively small diameter for insertion into the catheter. Once inside the catheter, stent **10** may be advanced to the desired location within a body vessel according to methods known in the art and discharged from the catheter at that location. U.S. Pat. Nos. 5,405,377 and 5,609,627, the disclosures of which are incorporated herein by reference, contain additional details regarding the formation, use, and insertion of nitinol stents. Those patents are incorporated herein by reference for their teaching on those subjects. When stainless steel, thermoplastic polymers, or other materials are used for wire **11**, formation, use and insertion of stent **10** may be accomplished according to methods known to those skilled in the art.

[0028] Connective spine **16** lends strength, including hoop strength, to stent **10** during and after implantation to better resist compressive forces within the vessel in which stent **10** is implanted. Connective spine **16** also allows flexibility, however, such that stent **10** may be easily compressed and expanded during the insertion process.

[0029] Particular features of the stent according to this embodiment of the invention are illustrated in FIG. 2. As shown in FIG. 2, facing apex sections **15** of respective adjacent hoops of stent **10A** are offset circumferentially from one another by a distance **D1**, as opposed to abutting one another. The offset allows stent **10A** to be compressed to a smaller diameter (profile) for insertion into the catheter because the apex sections do not contact one another and hinder such compression. Increasing the axial distance **D2** between apex sections **15** (the “zig gap”) also prevents interference between these sections during compression. The particular amount of offset and zig gap can be optimized according to particular stent sizes and the desired flexibility and compressed diameter as will be understood by those skilled in the art.

[0030] FIG. 2 also illustrates an embodiment of this invention having multiple, in this case two, connective spines **16**. To form two connective spines **16**, two separate wires **11** and **11A** are used to form stent **10A**. As shown in FIG. 3, first wire **11** is formed in a zig-zag shape extending from point A to points B, C, D, E, F, G, H, I, J, K, L, M, N, O, P (etc.) sequentially. A second wire **11A** is used to form the remainder of the stent by extending, in sequence from point E to points Q, R, S, A, T, U, V, W, X, V, Z (etc.). In this manner, each hoop contains two pairs of aligned, adjacent struts **14a** and **14b**. Aligned, adjacent struts **14a** and **14b** are then welded (or otherwise connected) to form connective spines **16**. In general, the number of wires **11**, **11A**, etc. used to form stent **10A** directly corresponds to the number of connective spines **16** that are desired. The strength and rigidity of stent **10A** increase with the addition of connective spines **16**.

[0031] In the above configuration, the mandrel peg at each lettered point may be considered to be one of a set of pegs corresponding to the wire to wound about the set. Thus, pegs at points A, B, C, etc. above are a part of one set, and pegs E, Q, R, etc. above are part of a second set. Each set, however, contains at least one common peg (for example, F in the first set and W in the second set) where both wires follow a

common path between the common pegs of the circumferentially adjoining sets. The wires that form the common path (adjacent struts **14a** and **14b**) are connected as described above.

[0032] FIG. 3 illustrates another alternative embodiment of this invention wherein the zig length  $L_1$  is varied within stent **10B**. Zig length  $L_1$  is the distance between apex sections **15'** and **15''** measured in a direction parallel to the stent axis (vertical, in FIG. 3). As previously indicated, the zig length may similarly be described as the amplitude of a sinusoidally shaped zig-zag. In this embodiment, the zig length at end sections **22** of stent **10B** may be relatively short (relatively small amplitude), while the zigs in middle section **20** of stent **10B** are relatively long (having greater amplitude). This may provide greater radial force at the ends of stent **10B** to assist in anchoring the stent in place in the vessel into which it is inserted by asserting a greater force against the walls of the vessel. This may also prevent blood from leaking between stent **10B** (when the stent is used in combination with a graft, as will be understood by those skilled in the art) and the vessel wall.

[0033] As illustrated in FIG. 3, there may also be a transition section **21** in which there is a transition zig length, between the short zig length at the stent ends **22** and the long zig length in the stent middle **20**, to provide a gradual transition from the short to the long zigs. Typical short zig lengths are between two and three millimeters. Typical long zig lengths are between three-and-a-half and five millimeters. The actual zig lengths may be optimized for particular applications as will be understood to those skilled in the art based on the disclosure herein.

[0034] Another aspect of this invention involves the variation of the number of zigs in each hoop member. Referring back to FIG. 1, a “zig” is considered to be the part of wire **11** extending from, for example, point X to point Y to point Z. X-Y-Z in FIG. 1 is considered to represent one zig. Thus, each similarly-oriented apex section (i.e. each apex section pointing in the same direction) defines a zig. As previously indicated, the number of zigs in a hoop may be similarly described as the number of periods of a sinusoidally shaped zig-zag. In FIG. 1, each hoop member has five zigs. Using fewer zigs allows stent **10** to be compressed to a smaller insertion diameter (that is, fewer zigs decreases the profile of stent **10**). Increasing the number of zigs provides more support for any graft covering used in conjunction with the stent, however, preventing the possibility of in-folding of such graft layer.

[0035] FIG. 4 illustrates an alternative embodiment, not drawn to scale, wherein the center portion **20** of stent **10** has four zigs per hoop member **12**, a first zig length, and one connective spine **16**; and the end portions **22** have six zigs per hoop member **12**, a second zig length, and two connective spines **16**. The second spines on both ends overlap two hoop members **12** of the center portion as a transition. The number of connective spines **16** can thus be varied within a stent to provide a more rigid portion at the ends and a more flexible portion in the middle. The stent illustrated in FIG. 8 may have, for example, a wire diameter of 0.007 inches, a 6.4 mm OD, a 6 mm ID, and a length of 100 mm. Other wire diameters slightly larger than 0.007 inches such as 0.008 or 0.009 inches, for example, will suffice.

[0036] As shown in FIG. 9, another method of making connecting members may comprise axially opposed apex sections **15** of adjacent hoops **12** being axially spaced from one another with one or both of the first and second struts **14'**

of the connecting member elongated relative to the remainder of the struts **14** in the adjacent hoops. Such elongated struts **14'** may thus lie adjacent one another for at least some axial distance to permit connection therebetween.

[0037] FIG. 5 illustrates a stent constructed according to another exemplary embodiment of the present invention. Stent **30** is generally cylindrical and adapted to be inserted into a lumen. Stent **30** has been cut longitudinally and laid flat for purposes of illustration. Stent **30** is formed by winding a continuous filament such as a wire **24** into a zig-zag configuration and into a plurality of circumferential hoop members **33**, **25a** . . . **25N**, and **37** disposed in succession along the axis of stent **30**. Wire **24** is extended to and around pins **23a**, **23b**, **23c** and so forth. In this manner, zig-zag members are formed and defined by a successive series of substantially straight sections **34** connected by apex sections **35** alternately pointing in opposite axial directions. The winding continues in this manner around the mandrel until a first hoop member **33** is completed by winding wire **24** once around the circumference of the mandrel. Winding then continues as before to form a second hoop member **25a** adjacent to first hoop member **33** and a third hoop member **25b** adjacent to second hoop member **25a**. Unlike hoop members **12** of stent **10** as shown in FIG. 1, hoops **25a** . . . **25N** are disposed at an angle to a plane perpendicular to the stent longitudinal axis; wire **24** then gradually spirals about the axis of stent **30** to form a coil. End hoops **33** and **37**, however, are disposed perpendicular to the stent axis. The helical configuration may be effected by each apex section in the helix having one connected strut longer than the other.

[0038] As further illustrated in FIG. 5, adjacent hoops are connected by a separate bridging member **26** adjacent portions of respective straight sections **34** and **34A** of axially opposed apex sections of adjacent hoops. As illustrated in FIG. 5, bridging member **26** is preferably linear and aligned with aligned struts **34** and **34A** of proximate sections of adjacent hoops **25<sub>i</sub>** and **25<sub>i+1</sub>** although non-linear and non-aligned bridging members are also contemplated in accordance with the present invention, as may be appreciated by those skilled in the art. Separate bridging "member **26** may be the same material as or a different material than wire **24** used to form hoops **33**, **25a-N**, and **37** of stent **30**, depending on the desired flexibility and compressed stent diameter. In one embodiment, separate bridging member **26** and wire **24** are made of the same material, for example, nitinol. Separate bridging member **26** and wire **24** may have approximately the same or different cross sectional dimensions (i.e. the same or a different wire gauge), depending on the desired implementation.

[0039] An exemplary separate bridging member **26** is preferably formed by extending a wire segment between a pair of pins **28** extending from the mandrel proximate straight sections **34** and **34A** of adjacent hoops **25<sub>i</sub>** and **25<sub>i+1</sub>**. These pins **28** and **29** are in addition to pins **23a**, **23b**, etc. used to form zig-zag members of the respective hoops of stent **30**. Wire-segment bridging member **26** is extended between pins **28** and both ends are at least partially wrapped around the pins, preferably with enough tension to remove unwanted slack from the wire, although various amounts of slack may be maintained, depending on the desired rigidity, flexibility, and compressed diameter of stent **30**.

[0040] To effect welds during manufacture of a stent of the present invention, and as shown in FIG. 5, ball weld cutting holes **29** may be formed in the mandrel providing access to

the mandrel interior, the holes desirably positioned such that sections to be welded, such as aligned, adjacent struts **34** and **34A**, lie approximately above the ball weld cutting holes. In this way, a laser may be focused into ball weld cutting holes **29** to: (i) remove excess wire extending past ball weld cutting holes **29** and around the pins, and (ii) weld the remaining wire segment between the aligned, adjacent struts of adjacent hoops as, for example, bridging member **26** between struts **34** and **34A**. The connection between bridging member **26** and struts **34** and **34A** may, instead of a weld, may be accomplished according to any other suitable attachment means, including without limitation, tying, suturing, gluing, and stapling, with the glue or sutures being absorbable or non-absorbable, and including the use of polymer-containing connections.

[0041] As further illustrated in FIG. 5, a stent **30** constructed in accordance with the present invention may further include the plurality of separate bridging members **26a-26N** disposed in succession along the length of the stent. Each successive separate bridging member **26**, connects a successive pair of adjacent hoops along the axis of stent **30** to form a spine along the length of stent **30**. The spine may be a continuous spine of helically-aligned bridging members, similar to the spine illustrated in FIG. 1, or may be constructed of a single bridging member connecting a plurality of hoops along the length of the stent. Alternatively, as shown in FIG. 5, each successive connecting member **26**, may be circumferentially offset from a preceding connecting member with respect to the axis of stent **30** to define a helical spine of disjointed connecting members, or a "floating" spine. Hoop members **33**, **37** disposed at each end of stent **30** may have the apex sections that point outwardly from the stent disposed in common planes perpendicular to the axis of stent **30**, such as apex sections **35'** of hoop **34** along plane I, as shown in FIG. 5.

[0042] To make this transition from hoops other than perpendicular end hoops **33** and **37** to the end hoops, the successive lengths of struts in the end hoops may be reduced along the circumference of the hoops. Additionally, or in the alternative, the successive amount of interdigitation (overlap) between apex sections of adjacent hoops may increase along the circumference of end hoops **33** and **37** approaching the end of wire **24**.

[0043] FIGS. 6A-6E illustrated stent **40**, another exemplary embodiment of the present invention. In stent **40**, adjacent hoops **42a** . . . **42N** are interdigitated with respect to one another. That is, oppositely directed apex sections **44A** and **44B** in respective adjacent hoops **42b** and **42c**, for example, overlap one another axially, or expressed another way, they intersect a common plane angularly disposed with respect to the axis of stent **40**. Hoop members **42a** . . . **42N** also preferably have zigs substantially in phase circumferentially about stent **40**. Stent **40** comprises a continuous series of similarly-oriented apex sections **44A** arranged in a helix in which each hoop **42**; comprises one 360-degree wrap of the helix. Each apex section in the helix comprises two struts attached thereto, in this embodiment with one strut being longer than the other to effect the helical progression. Such a hoop configuration is also seen in U.S. Pat. No. 5,575,816 to Rudnick et al., which is incorporated herein by reference and which illustrates a variety of other interdigitated stent configurations.

[0044] In a pair of adjacent hoops, such as hoops **42b** and **42c**, one strut **45** of hoop member **42b** is aligned with and

overlaps strut 45 of hoop member 42c, and is connected to form a connecting member 48a-N, preferably by spot welding, although other connection mechanisms are contemplated as will be understood by those skilled in the art. Interdigitated stent 40 in its normal tubular form is illustrated in FIG. 6E.

[0045] Referring now to FIG. 10, there is shown a helical stent 110, corresponding to the layout shown in FIG. 6A, on a tubular mandrel 114. Helical stent 110 or a helical segment thereof, as shown in FIG. 10, may be constructed by winding N filaments 111, where N is a whole number of at least 1, around N respective sets of pegs 112a-N on a tubular mandrel 114. As shown in FIG. 11, N=1. Each of the N sets includes at least three axially offset pegs, such as pegs 112a, 112b, and 112c, defining a zig-zag configuration at a preselected axial location on mandrel 114, with circumferentially successive pairs of pegs (pegs 112c and 112d, for example) being axially offset in a preselected direction from the pair which precedes it (pegs 112a and 112b) so as to form a helical zig-zag pattern repeatedly traversing the mandrel along the length of stent 110. Each traversal of a preselected angular portion of mandrel 114 by pegs 112a-N includes at least one common peg (112r, for example) approximately 360° helically offset from an adjacent peg (112k). The peg adjacent the common peg may be part of the same set of pegs (for instance, where N is equal to 1) or a part of a circumferentially adjoining set of pegs (where N is greater than 1). Common peg 112r provides at least one circumferential location in each traversal of a preselected angular portion, where a portion of the filament in each traversal of a preselected angular portion contacts a portion of a filament in an adjacent traversal. This contact may be with the same filament (for instance, where N is equal to 1 as shown in FIG. 11) or with a different filament (where N is greater than 1). A connection 48 is formed along the contacting adjacent filaments or portions thereof, forming a circumferential stent or segment thereof comprised of a helical succession of zig-zags. Thus, the wire configuration may form a helix as shown in FIGS. 6A, 6E, and 11, or a double- or other multiple-helix (not shown). As shown in FIG. 6A, a single filament (N=1) repeatedly traverses the mandrel (not shown) along a single set of pegs, wherein in each angular traversal of 450° there is a common peg 13' approximately (in this case slightly greater than) 360° offset from an adjacent peg 13' (the pegs immediately adjacent each connecting member 48a-N).

[0046] Stent 40 as shown in FIG. 6A comprises a plurality of connecting members 48a-N disposed in succession along the stent axis between pairs of adjacent hoops. Each set of connecting members 48a-N connects a successive pair of adjacent hoops along the axis of stent 40 to form a spine along the length of the stent. As with the successive connecting members 26 of FIG. 5, each pair of successive connecting members 48; is circumferentially offset from a preceding connecting member 48<sub>n-1</sub> with respect to the axis of stent 40.

[0047] As shown in FIG. 6A, each apex section 44B includes an apex angle  $\alpha$  and a zig width W measured between adjacent, apex sections 44A opposite apex section 44B. As shown in FIG. 6A, the included angle (zig angle) and zig width of apex sections 44B are essentially uniform throughout stent 40, except for the apex sections 44W and 44W' that include the struts 45 that form connecting members 48a-N. Apex sections 44B' and 44B'' have a non-uniform zig angle and resulting zig width as compared to apex sections 44B. As shown in FIG. 6A, the zig including apex section 44B' has a greater included angle and has a greater zig width

than the uniform angle and width included by apex sections 44B; apex section 44B'' has a lesser included angle and smaller zig width than the uniform angle and width. As shown in FIG. 6A, stent 40 comprises a helical configuration having 4 zigs per 360-degree wrap, each such wrap comprising a hoop. Apex section 44W is spaced 5 zigs from each preceding 44B'; apex section 44B'' is similarly spaced 5 zigs from each preceding 44B'. Thus, for a stent with N zigs, the non-uniform zigs are spaced every N+1 zigs to achieve the helical pattern of connections 48a-N as shown in FIG. 6A. In other words, for the 4-zig stent of 6A, connecting members 48a-N are uniformly distributed in a helical spacing approximately every 450° along the length of the stent to form a helical spine. Other helical or non-helical spine configurations may be achieved by spacing the non-uniform zigs differently.

[0048] FIGS. 6B and 6C illustrate exemplary spot weld configurations within stent 40. For adjacent, aligned struts 48b-48<sub>n-1</sub>, the portion of each strut adjacent one another may be of a first length having a weld 54 of length L<sub>1</sub>, as shown in FIG. 6B. For adjacent, aligned struts 48a and 48N on the end hoops, however, the portions of each strut adjacent one another may be longer, and thus may include a weld 56 of length L<sub>2</sub>, as shown in FIG. 6B. To avoid sharp edges protruding from the stent, end strut 58 may be cut, as shown in FIG. 6C, so that it terminates a distance D from weld 56 in a position that lies short of plane II on which apex section 46 lies. For instance, the end of end strut 58 may be cut so that it terminates a distance above plane II equivalent to the radius R of apex section 46. As shown in FIG. 6A, end strut 58 has not yet been cut, but may be cut using ball weld cutting hole 29, similar to those described with reference to FIG. 5.

[0049] FIG. 6D illustrates an exemplary radiopaque marker 59 that may be used with the present invention. Marker 59 may comprise a radiopaque substance, such as a platinum wire, wrapped about a strut on an end hoops. This substance thus defines a surface having a different radiopacity than the area surrounding it. This same effect may be achieved by marking a particular location of the stent with an area of lower radiopacity. One or more markers 59 may be disposed on one or both of the end hoops. Marker 59 generally may be tightly wound with no underlying strut visible to the unaided eye, and may extend 1-2 wraps past the start of the radius where the strut bends to form the apex section. Marker 59 is typically configured without sharp edges at the ends.

[0050] FIG. 6F is a diagrammatic view of an exemplary embodiment of stent 60, opened along a line parallel to the stent axis and flattened, having interdigitated zigs, similar to stent 40 of FIG. 6A-E, but additionally having a plurality of longitudinal sections, similar to stent 10C as shown in FIG. 4. Middle section 62 has a longer zig length than end sections 64, and transition sections 63 intermediate the middle section and each end section have a zig length that is between the length of the middle and the end section zigs.

[0051] FIG. 7 illustrates still another stent 70 constructed in accordance with the present invention. Stent 70 has been cut longitudinally and laid flat for purposes of illustration. Stent 70 is formed by winding a wire around pins extending from a mandrel somewhat similar to the manner described with reference to FIG. 1, although the pins are configured such that zig-zag sections of respective hoops 76a, 76b, 76c, 76d are of varying height and varying width. In the embodiment illustrated in FIG. 7, the width of the zig length alternates between distance XX and WW along each hoop circumferentially about stent 70. The zig length similarly alternates between

length YY and ZZ moving along each hoop circumferentially about stent 70. Length ZZ is approximately half of length YY in FIG. 7, although other length variations are contemplated. Adjacent hoops, such as hoops 76a and 76b, are phase-shifted by approximately 180 degrees and inverted with respect to one another. Accordingly, apex sections 65 and 66 of hoop member 76a pass through a plane perpendicular to the axis of stent 60 determined by the positions of oppositely directed alternate apex sections 67 and 68 in adjacent hoop 76b. The configuration of FIG. 7 may be incorporated into transition segments of other stents constructed according to the present invention.

[0052] A series of separate bridging members 72a, 72b, and 72c connects adjacent hoops 76a and 76b, as shown in FIG. 7. Another series of separate connecting members 74a and 74b connects adjacent hoops 62b and 62c. Bridging members 72a, 72b, and 72c are angled relative to the tubular axis of stent 70 in opposite orientations than bridging members 74a and 74b, to counter rotating effects in stents in which bridging members between successive pairs of adjacent hoops are oriented in the same direction. The number of bridging members may vary, depending on the desired implementation, as may the orientations of bridging members 72a, 72b, 72c, 74a and 74b.

[0053] Stent 80 of FIG. 8 is formed by winding a first wire 81 around pins (not shown) on a mandrel. The geometry of the pins may be substantially circular to produce rounded apex sections, as in FIG. 1, or have straight edges such as to produce apex sections having straight edges as in FIG. 8. In this manner, zig-zag members are formed and defined by a successive series of struts 84 connected by apex sections 85 alternately pointing in opposite axial directions. The winding continues in this manner around about half the circumference of stent 80. A second wire 86 is introduced and wound around the remaining circumference of stent 80 to complete a first hoop member 82a. Where wires 81 and 86 overlies one another, they may be spot or linearly welded, thus to produce a pair of helical spines lending integrity to stent 80.

[0054] Any of the variations described herein may be combined with any other variation described herein or known in the art, where practical, to develop a stent architecture according to the present invention. Such variations may be uniformly utilized throughout the length of the stent, or as shown in FIG. 6F, the stent may comprise a plurality of longitudinal sections, each of which may differ from another segment with respect to, for example without limitation: the size of one or more of the apex section angles, the apex section axial length, the number of apex sections per hoop, the number of connective spines, the spacing or offset between facing apex sections, the type of connecting member, and the uniformity of adjacent zigs. Moreover, the "struts" of each apex section and

the connections therebetween may be straight, as in a jagged zig-zag configuration, or curved somewhat, such as when the overall stent section is more sinusoidal.

[0055] Although this invention has been described with reference to particular embodiments, it is not intended that this invention be limited thereto. Rather, the scope of the appended claims should be construed to cover all forms and variants of the invention as may be made by those skilled in the art without departing from the spirit and scope thereof.

What is claimed:

1. A stent having a circumference and a longitudinal axis, the stent comprising a first end, a first end section, a middle section, a second end section, and a second end, the middle section engaged to and extending between the first and second end sections;

the first end section comprising a plurality of substantially straight portions connected one to another by turns, the plurality of substantially straight portions and turns forming a circumferential ring that extends about the circumference of the stent,

the middle section comprising a plurality of substantially straight portions connected one to another by turns, the plurality of substantially straight portions and turns forming a plurality of helical hoops, the plurality of substantially straight portions comprising first substantially straight portions having a first length and second substantially straight portions having a second length less than the first length; and

the second end section comprising a plurality of substantially straight portions connected one to another by turns, the plurality of substantially straight portions and turns forming a circumferential ring that extends about the circumference of the stent.

2. The stent of claim 1 wherein some of the turns form the first end of the stent, the turns forming the first end being intersected by a plane which is perpendicular to the longitudinal axis of the stent and some of the turns form the second end of the stent, the turns forming the second end being intersected by a plane which is perpendicular to the longitudinal axis of the stent

3. The stent of claim 1, the substantially straight portions of the first end section and the substantially straight portions of the second end portions having variable lengths.

4. The stent of claim 1, the substantially straight portions of the first end section being substantially the same length and the substantially straight portions of the second end section being substantially the same length.

5. The stent of claim 1, helical hoops which are longitudinally adjacent one another are engaged by a connector, the connector engaging two substantially straight portions.

\* \* \* \* \*