

993,741.

Patented May 30, 1911.

4 SHEETS-SHEET 1.

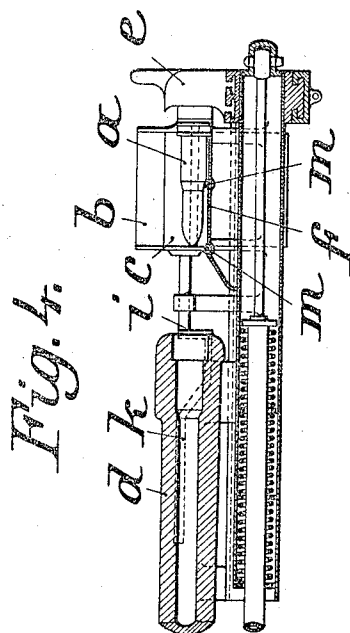
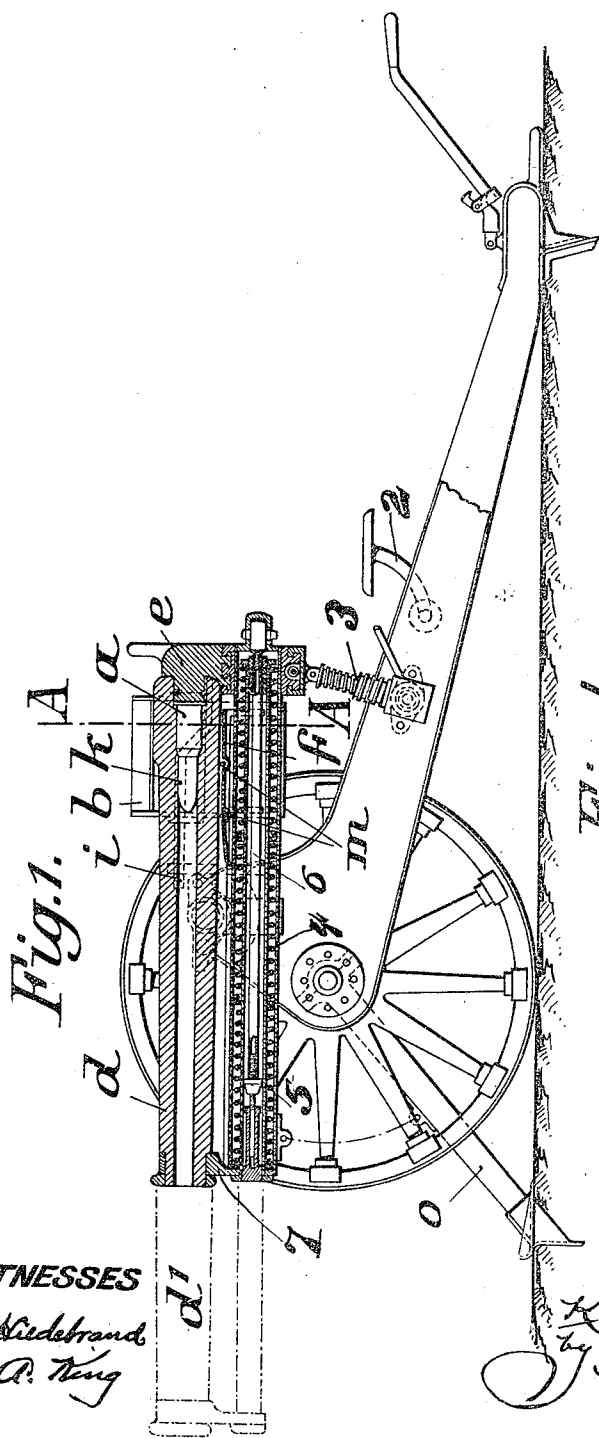

WITNESSES

E. E. Liebrand
J. P. King

INVENTOR

Karl Völler
 by *Georgi & Massie*
 ATTORNEYS

K. VÖLLER.
AUTOMATIC RAPID FIRE CANNON.
APPLICATION FILED AUG. 22, 1907.

993,741.

Patented May 30, 1911.

4 SHEETS—SHEET 2.

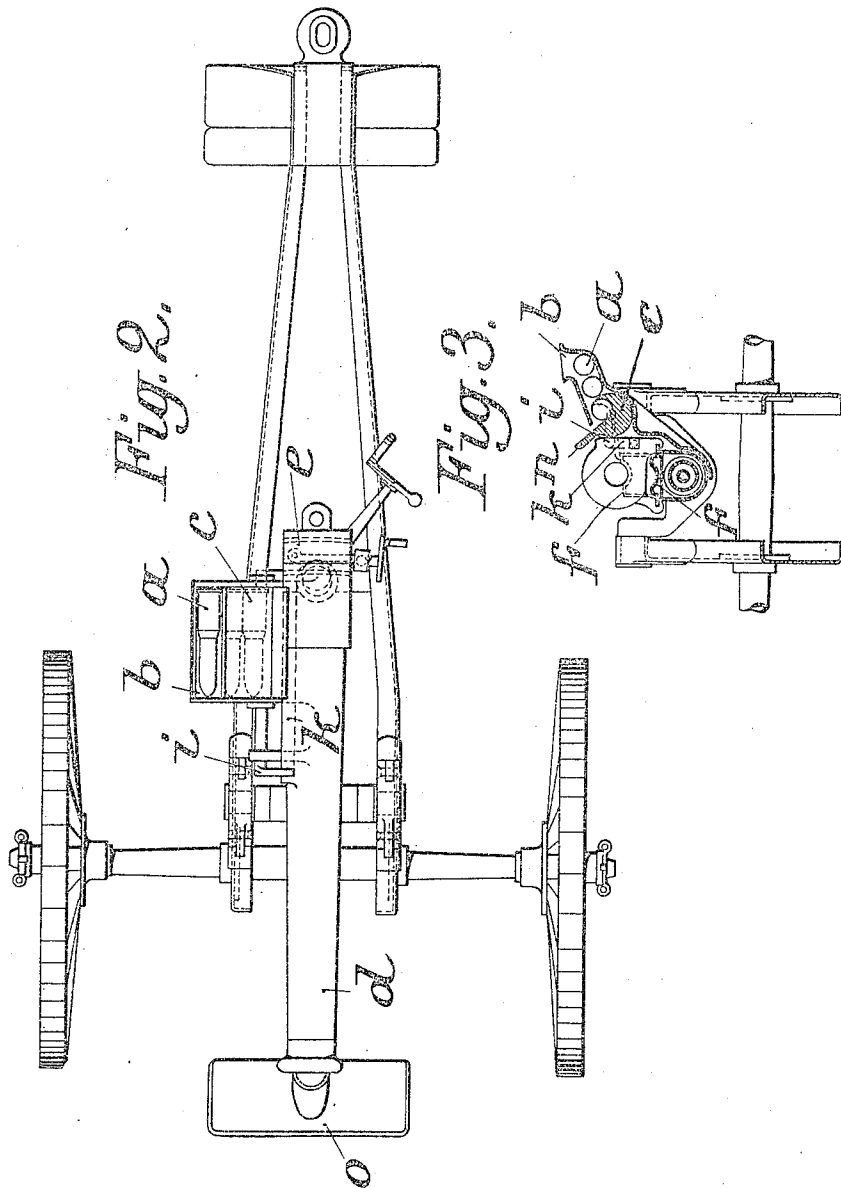

WITNESSES

E. Hildebrand
J. A. King

INVENTOR

Karl Völler
by *Georgi Masas*
ATTORNEYS

Fig. 5.

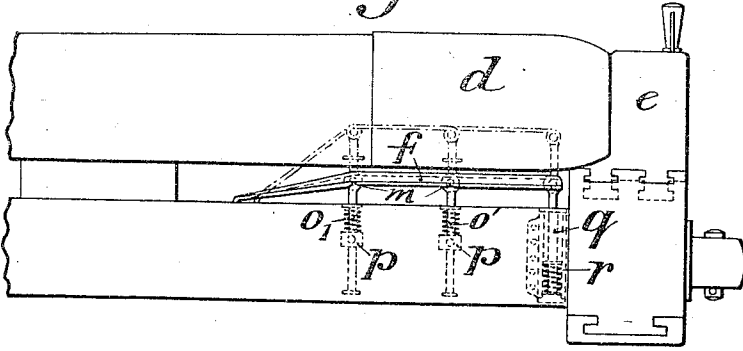

Fig. 7.

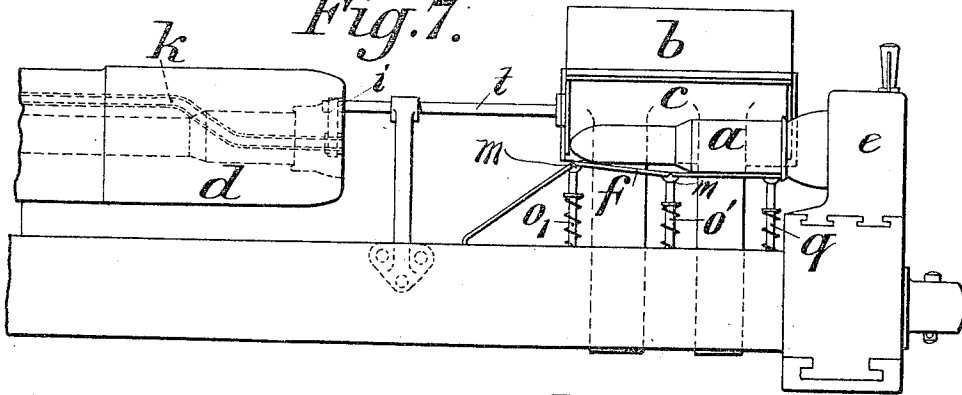

Fig. 6.

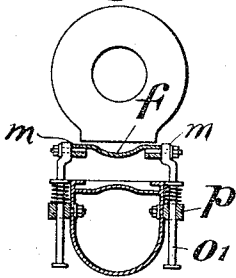
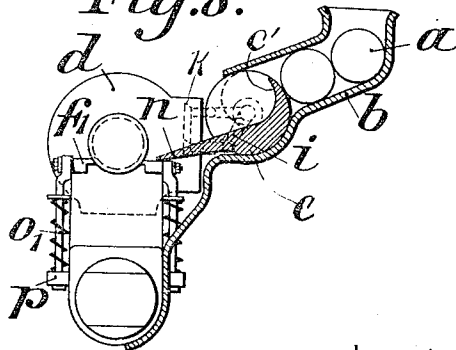

Fig. 8.



WITNESSES

E. Hildebrand
M. B. Taylor

INVENTOR

Karl Völler
 by *Georgii Masch*
 ATTORNEYS

Fig. 9.

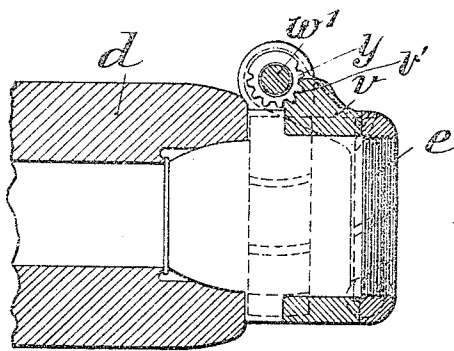
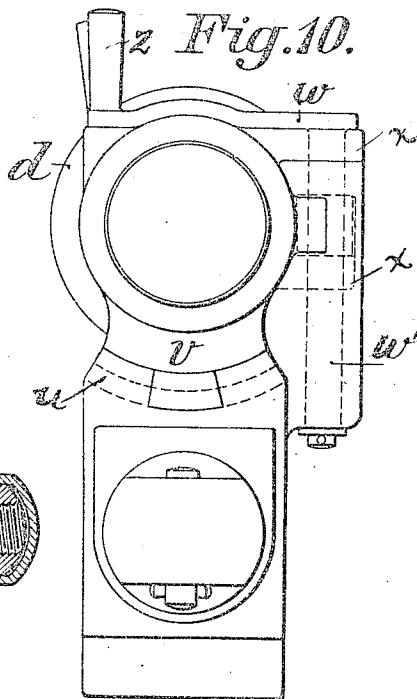
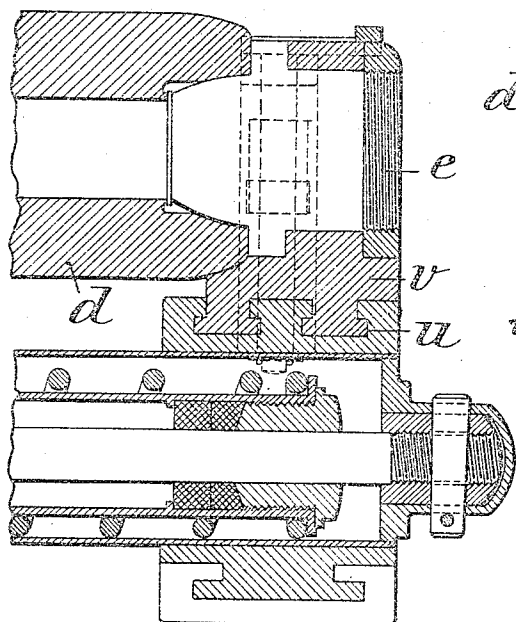

Fig. 11.

WITNESSES

E. Schickel
 M. B. Taylor

INVENTOR

Karl Voller
J. G. G. & Massey
 ATTORNEYS

UNITED STATES PATENT OFFICE.

KARL VÖLLER, OF DUSSELDORF, GERMANY.

AUTOMATIC RAPID-FIRE CANNON.

993,741.

Specification of Letters Patent.

Patented May 30, 1911.

Application filed August 22, 1907. Serial No. 389,713.

To all whom it may concern:

Be it known that I, KARL VÖLLER, engineer, a subject of the German Emperor, residing at 17 Fülcherstrasse, Dusseldorf, Germany, have invented certain new and useful Improvements in Automatic Rapid-Fire Cannons; and I do hereby declare the following to be a full, clear, and exact description of the invention, such as will enable others skilled in the art to which it appertains to make and use the same.

This invention relates to improvements in automatic rapid fire cannons and has for its object the provision of means whereby the operations of opening the breech, loading the gun and closing the breech will be performed automatically by the movement of the barrel under the influence of the expanding gases, whereby the loss of time usually due to these operations will be prevented and the rapidity of firing of the cannon will be increased.

Other incidental objects of the invention will hereinafter appear.

In the accompanying drawings which fully illustrate the invention, Figure 1 is a longitudinal vertical section of a cannon embodying the improvements; Fig. 2 is a plan view of the same; Fig. 3 is a detail transverse section on the line A—A of Fig. 1; Fig. 4 is a detail longitudinal section of the rear end of the barrel showing a cartridge in position to be inserted within the barrel; Fig. 5 is an enlarged view of the device as shown in Fig. 4 with the barrel thrown backward against the breech; Fig. 6 is a detail view showing the loading bridge in its lowered position; Fig. 7 is a side elevation of the mechanism shown in Fig. 4, and on a larger scale; Fig. 8 is a transverse section similar to Fig. 3, but on a larger scale and showing the parts in a different position; Figs. 9 and 11 are respectively vertical and horizontal sections of the breech mechanism; and Fig. 10 is an end elevation of the same.

The cannon is supported on the usual carriage which is provided with a forwardly extending spur or brace *o*, which may be telescopic in construction so as to be raised and supported by the carriage when the cannon is being moved from place to place, and upon the carriage I provide a seat 2 for the gunner, while adjacent to the said seat is arranged the usual jack or hoisting screw 3 to permit the gun to be given proper elevation. This screw 3, as clearly shown, is con-

nected to what I term the upper carriage, which consists essentially of a cylinder 4 in which is mounted a returning spring 5 and a fluid pressure brake mechanism 6, the said spring serving to hold the gun barrel *d* against the breech block *e* and the brake mechanism serving to gradually absorb the energy of the forwardly moving barrel *d* in the act of firing. The barrel *d* is provided at its front end with a depending plate or lip 7 which is connected to the piston of the fluid pressure brake so as to operate the same and to compress the return spring 5 during the forward movement of the barrel, as will be readily understood. The rear end of the barrel engages over the breech block *e* and is provided on one side with a cam groove *k*, the purpose of which will presently appear.

The cartridges *a* are placed in a magazine *b* which projects laterally from the rear end of the upper carriage and is so arranged that the cartridges placed therein will roll downward through the magazine to a position in front of the breech block and in alignment with the gun barrel. The movement of the cartridges downward through the magazine is intercepted by a feeding tray *c* having an inwardly extending arm *n* and a curved tooth or lip *c'*, the said tooth or lip being arranged to engage between two adjacent cartridges when the tray is in the loading position, and thereby arrest the movement of all the cartridges except the one on the tray, as will be readily understood on reference to Fig. 8. In the position of the tray shown in the said Fig. 8, the arm *n* will rest upon a loading bridge *f* and will form an inclined plane down which the cartridge may roll on to the said bridge when it will be supported by the said bridge directly in front of the breech block and in alignment with the gun barrel as clearly shown in Fig. 7, the fired cartridge being shoved laterally from the bridge by the loaded cartridge rolling thereon, as will be understood. The said loading bridge *f* is supported by rods *o'* passing through lugs *p* which are pivoted on the sides of the upper carriage, the bridge being pressed upward by springs coiled around the said rods between the said lugs and annular shoulders on the rods, as clearly shown and as will be understood.

The bridge is constructed in sections or links which are connected by hinges *m* at the

upper ends of the rods o' , whereby the bridge will move flexibly under the barrel so as to secure the desired ease of operation. The front section of the bridge, as clearly shown in Figs. 5 and 7, rests directly upon the upper carriage or brake cylinder 4, whereby it presents an inclined surface to the end of the moving gun barrel so that the bridge will operate without any jerk or shock. The rear end of the bridge is supported by a rod g which is normally pressed upward by a suitable spring and is secured in a cylindrical casing r upon the upper carriage, whereby the rear end of the bridge will be permitted to move in a vertical plane only. The sectional construction of the bridge not only provides for smooth movement of the several parts, but also permits the bridge to accommodate itself to the outline of the cartridge so as to support the cartridge in a true horizontal position, as shown in Fig. 7.

The loading tray c is pivotally mounted in the walls of the lower end of the magazine b and its front pivot is extended forward in the form of a shaft t mounted in suitable bearings on the side of the carriage, and provided at its front end with a jointed crank arm i , the end of which engages the cam groove h in the side of the barrel, whereby, as the barrel moves forward and backward, the loading tray will be rotated to permit the feeding of the cartridges as before stated.

In Figs. 9, 10, and 11 I have illustrated a construction whereby the breech block may be manually moved away from the barrel, it being understood that the first cartridge must be placed in its loading position manually and that the subsequent operations are accomplished through the firing of the gun. In the construction shown in these Figs. 9, 10 and 11, the rear end of the upper carriage is provided in its upper side with grooves u arranged concentrically with the gun barrel, and in the said grooves is mounted a guide v which carries the breech block e and is so constructed as to lock the block in place in its normal position the block being capable of rotation but incapable of sliding and the guide v being constructed with a bayonet-joint lock. At one side this guide is provided with an off-set having teeth v' which mesh with a pinion y formed on the crank pin w' of a crank w , which is journaled in a projection on the side of the upper carriage and is provided with a handle z by means of which it may be operated. The breech block e is constructed with a pair of outstanding ears x which encircle the crank pin w' and thereby permit the breech block to be swung around the axis of said pin. When the crank arm is moved rearward the gearing y and v' will turn the guide v upon the breech block so as to re-

lease the lock formed by the guide v and the grooves u in the upper carriage. A further movement of the crank will swing the breech block and the guide to the rear so as to free the breech opening. A cartridge being then inserted between the breech block and the barrel, the breech is brought back to its normal position and the operations above described will follow upon the firing of the cannon.

When the gun is fired the force of the explosion will move the barrel forward from the breech block. This forward movement of the barrel will cause the cam groove h to act on the crank arm i so as to rotate the shaft t and thereby turn the loading tray from the position shown in Fig. 3 to that shown in Fig. 8, whereupon the cartridge which had been previously received by the loading tray will roll down the same on to the bridge and eject therefrom the shell of the cartridge just fired. As the barrel returns to its initial position it will pass over and depress the loading bridge f so as to encircle the cartridge thereon, and the action of the cam groove and the crank arm i will cause a reverse movement of the shaft t and return the loading tray to the position shown in Fig. 3.

Having thus fully described my invention, what I claim is:—

1. The combination of a forwardly moving gun barrel, a breech block, means to normally hold the barrel against the breech block, and a fluid pressure brake to gradually arrest the forward movement of the barrel.

2. The combination of a forwardly moving gun barrel, a rotatable loading tray arranged at one side of the barrel and slightly above the center of the same, and intermediate connections whereby upon forward movement of the barrel the tray will be rotated to deposit a cartridge behind the barrel.

3. The combination of a forwardly moving gun barrel, a loading bridge arranged to support a cartridge in the rear of the barrel when the same is in its forward position, a loading tray arranged at one side of the bridge in position to deposit a cartridge thereon, and means actuated by the barrel to operate the tray to place a cartridge upon the bridge during the time of the forward movement of the barrel.

4. The combination with a forwardly moving gun barrel, of a magazine arranged at one side and above the center of the barrel, a rotatable loading tray interposed between the magazine and the side of the gun barrel and arranged parallel to the axis of the barrel, and means operated by the gun barrel to rotate the said tray and feed a single cartridge from the magazine to a position in rear of the barrel during the forward movement of the same.

5. The combination with a forwardly moving gun barrel, of a cartridge supporting bridge arranged in position to be depressed by the rear end of the barrel when the same is in its initial position, means for elevating said bridge into position to receive and support a cartridge, and other means operated by the movement of the barrel to place a cartridge on the bridge when the same is in its elevated position.

6. The combination with a forwardly moving gun barrel, of a cartridge supporting bridge arranged in position to be depressed by the rear end of the barrel when in its initial position, the said bridge consisting of links or sections flexibly connected, spring supports for the said bridge, and means operated by the movement of the barrel to place a cartridge on the bridge when the barrel is in its forward position.

7. The combination, with a forwardly moving gun barrel provided with a cam groove in its side, of a loading tray having a forwardly extending shaft, and a crank arm on said shaft engaging the groove in the gun barrel whereby the movement of the barrel will rotate the loading tray so as to effect a feeding of a cartridge on the tray into position to enter the barrel.

8. The combination with a magazine and a forwardly moving gun barrel, of a loading tray arranged in the lower end of the magazine at one side of the gun barrel and having a lip adapted to project upward between two adjacent cartridges in the magazine, and an extended inwardly projecting arm arranged to guide a cartridge received by the tray into position to enter the gun barrel, and means operated by the gun barrel to oscillate the said tray.

9. The combination of a forwardly moving gun barrel, a vertically movable bridge adapted to support a cartridge in rear of the barrel, a magazine arranged at one side of the barrel, a rotatable loading tray arranged at one side of the barrel in the lower end of the magazine, and means operated by the gun barrel to rotate the loading tray whereby a cartridge will be fed from the magazine on to the elevated bridge.

10. The combination of a forwardly moving gun barrel, a vertically movable cartridge-supporting bridge arranged in rear of the barrel, a magazine at one side of the barrel, a rotatable loading tray in the lower end of the magazine having an extended arm adapted to project upward and restrain a cartridge on the tray or to rest on the bridge and permit the cartridge to pass onto the same when it is in its elevated position, and means operated by the gun barrel for rotating the tray.

11. The combination of a forwardly moving gun barrel, a breech block, a loading tray arranged at one side of and slightly

above the barrel, means to automatically supply cartridges to the tray, and means actuated by the movement of the barrel to cause the tray to deposit a cartridge between the breech block and the barrel.

12. The combination of a forwardly moving gun barrel, a breech block, means to normally hold the barrel against the breech block, a fluid pressure brake to gradually arrest the forward movement of the barrel, a cartridge magazine arranged adjacent the breech block, a loading tray arranged to receive the cartridges from the magazine and deposit them in position to enter the breech upon the return of the barrel, and means actuated by the movement of the barrel to operate the tray.

13. In a gas operated gun, the combination, with a forwardly moving gun barrel, a breech block, means to normally hold the barrel against the breech block, and a fluid pressure brake to gradually arrest the forward movement of the barrel, of a loading device, and means actuated by the movement of the barrel to operate the loading device.

14. In a gas operated gun, the combination, with a forwardly moving gun barrel, a breech block, means to normally hold the barrel against the breech block, and a fluid pressure brake to gradually arrest the forward movement of the barrel, of a magazine adjacent the breech, a loading tray between the magazine and breech, and means actuated by the movement of the barrel to operate the loading tray to transfer the cartridges from the magazine to the breech.

15. In a gas operated gun, the combination, with a forwardly moving gun barrel, a breech block, means to normally hold the barrel against the breech block, and a fluid pressure brake to gradually arrest the forward movement of the barrel, of a bridge arranged to be brought into position to support a cartridge between the breech and barrel when the barrel is in its forward position and to be moved from such position by the return of the barrel.

16. In a gas operated gun, the combination, with a forwardly moving gun barrel, a breech block, means to normally hold the barrel against the breech block, and a fluid pressure brake to gradually arrest the forward movement of the barrel, of a bridge arranged to be brought into position to support a cartridge between the breech and barrel when the barrel is in its forward position and to be moved from such position by the return of the barrel, a magazine adjacent the bridge, and a loading tray operated by the moving barrel to transfer the cartridge from the magazine to the bridge when in its loading position.

17. In a gun, the combination, with a barrel and breech separated for loading by the action of the gases, of a bridge arranged to

receive and support a cartridge between the separated barrel and breech and to be depressed from such position by the return of the parts, the said bridge consisting of sections flexibly connected and spring supports for the sections.

5

In testimony whereof I have hereunto

affixed my signature in the presence of two witnesses.

KARL VÖLLER.

Witnesses:

M. ENGELS,

ALFRED POHLMÉYER.