

(12) UK Patent Application (19) GB (11) 2 163 818 A

(43) Application published 5 Mar 1986

(21) Application No 8521204

(22) Date of filing 23 Aug 1985

(30) Priority data

(31) 645399 (32) 29 Aug 1984 (33) US

(71) Applicant
Ferrofluidics Corporation (USA-New Hampshire),
40 Simon Street, Nashua, New Hampshire 03061, United
States of America

(72) Inventor
Kuldip Raj

(74) Agent and/or Address for Service
Graham Watt & Co.,
Riverhead, Sevenoaks, Kent

(51) INT CL⁴
F16J 15/40

(52) Domestic classification
F2B 13C10 13CX8
U1S 2119 F2B

(56) Documents cited
GB A 2087989 US 4357024
Note: GB A 2087989 and US 4357024 are equivalent;

(58) Field of search
F2B

(54) Self-activating ferrofluid seal apparatus and method of forming same

(57) A self-activating ferrofluid seal apparatus for use with a computer-disc-drive spindle (42) comprising an annular, axially-polarized permanent magnet (38) and first and second pole pieces (34, 36) in a magnetic-flux relationship with each side of the magnet and the one end of the pole pieces extending into a close, noncontacting relationship with the surface of the spindle (42) to be sealed to form a radial gap (44) with the surface of the shaft and ferrofluid (46) in the radial gap to effect a single-stage ferrofluid seal and wherein the annular permanent magnet has a thickness of not more than about 25 mils and an energy product of about 1.8×10^6 gauss-oersteds or greater and the ferrofluid (46) comprising a low-vapor-pressure ferrofluid having a magnetic saturation of at least 200 gauss or more.

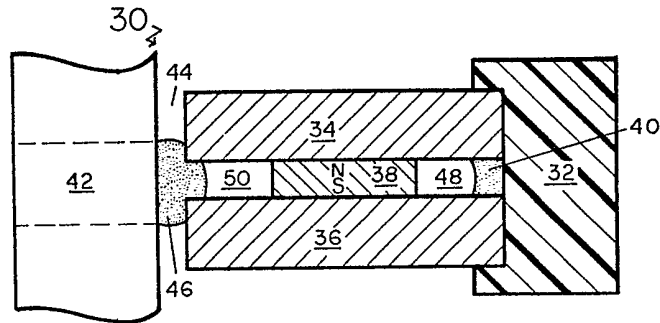
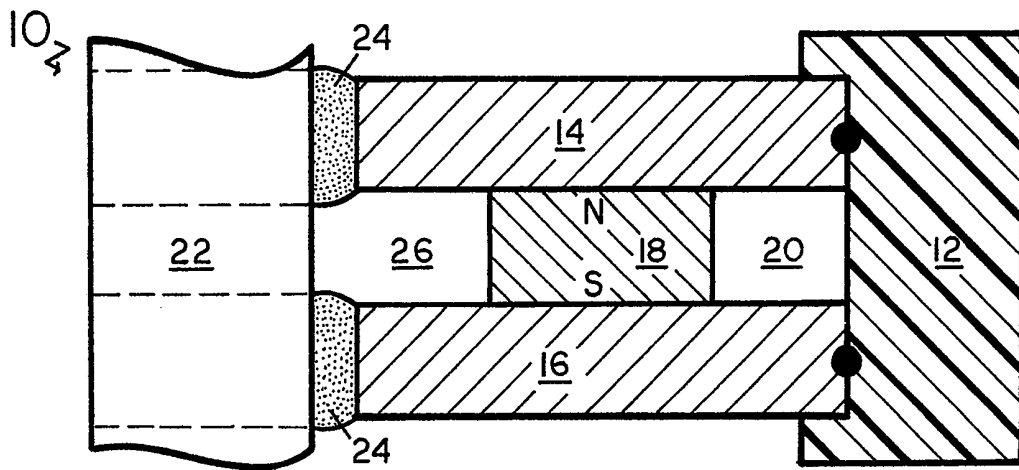

FIG. 3

GB 2 163 818 A



PRIOR ART

FIG. 1

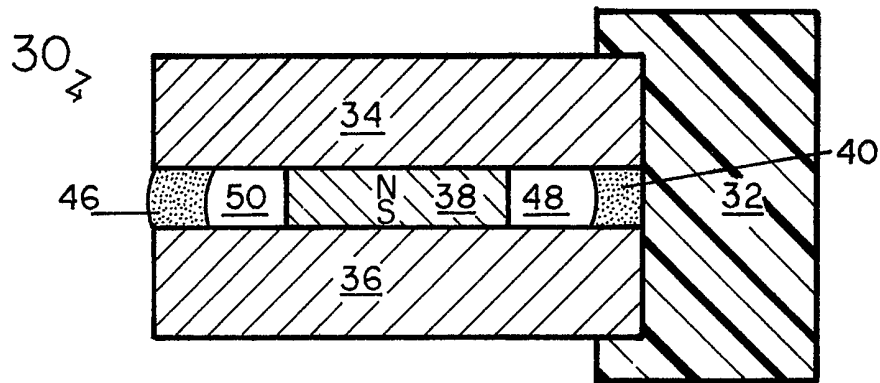

FIG. 2

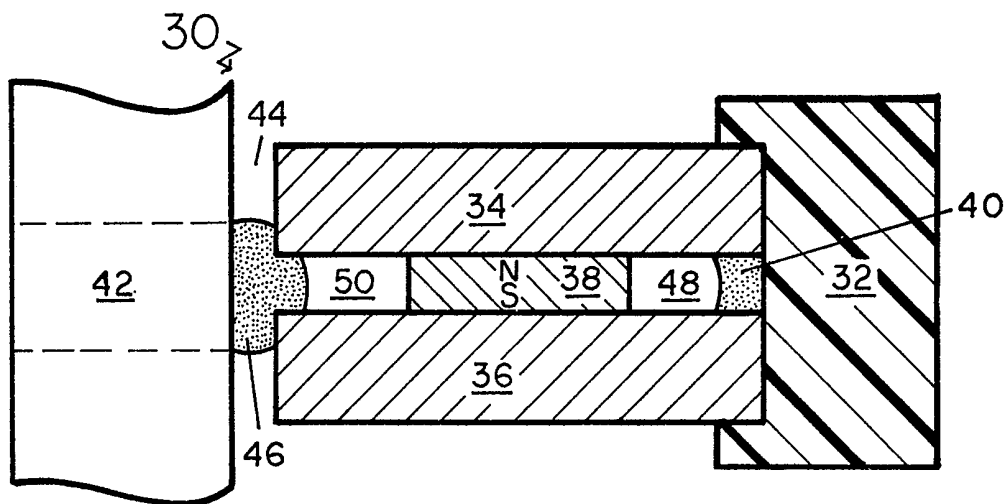

FIG. 3

SPECIFICATION

Self-activating ferrofluid seal apparatus and method of forming same

5 The present invention relates to a self-activating ferrofluid seal apparatus and method of forming same.

10 Ferrofluid-type seal apparatuses for use in sealing rotary shafts with single or multiple stage ferrofluid liquid O-ring seals about the shaft are well known. Ferrofluid seal apparatuses have been used as exclusion seals to protect one environment on one side of a shaft from contaminants in an environment on the other side of the shaft. Ferrofluid-type exclusion seals are particularly useful with computer-disc-drive spindles to prevent contamination in an environment from reaching a memory-disc area and where the exclusion seal does not require large pressure capacity. A standard ferrofluid exclusion seal presently employed comprises an annular, axially polarized ring-like permanent magnet adapted to surround a shaft and sandwiched between two identical pole-piece elements which are placed in a contacting magnetic-flux relationship with the one and the other polar ends of the permanent magnet. The pole-piece elements at the one end extend into a close, noncontacting relationship with the surface of the shaft to form radial gaps therebetween. The ferrofluid is disposed and magnetically retained in the radial gaps on the insertion of a magnetically permeable shaft to form one or more liquid O-ring stages about the shaft which serve to form an exclusion seal.

35 Typically, for example, with a ferrofluid seal apparatus for use with a computer-drive shaft, the ferrofluid is shipped separately with the seal apparatus. The customer then installs the ferrofluid seal apparatus and inserts the shaft and then injects the ferrofluid inside the installed seal in order to activate the seal and to form a liquid O-ring seal about the shaft element inserted within the seal apparatus. This method of forming an exclusion seal is both time consuming and particularly subject to operator error in applying the proper quantity of the ferrofluid into the ferrofluid seal apparatus. The quantity of ferrofluid employed in the seal apparatus determines both the life and pressure capacity of the ferrofluid seal. It is therefore very desirable to supply a ferrofluid seal apparatus to a customer which already contains the proper quantity of ferrofluid, and which on the insertion of a magnetically permeable shaft into the seal apparatus, has the ferrofluid automatically filling the radial gap to provide the proper O-ring seal, thus in effect to be a self-activating seal.

60 The self-activating ferrofluid seal apparatuses have been disclosed in U.S. Patent No. 4,252,328 and U.S. Patent No. 4,252,353, both issued February 24, 1981. The self-activating ferrofluid seal apparatuses described provide for self-activating, that is movement of the ferrofluid from a nonactivating to an activating sealing position within the radial gap upon the insertion of a magnetically permea-

ble shaft. Such self-activating ferrofluid seal apparatuses are not wholly satisfactory, since the manufacturing cost of such self-activating seal apparatuses tend to be higher than for standard exclusion seals.

70 In addition, U.S. Patent No. 4,357,024, issued November 2, 1982, describes a ferrofluid seal apparatus designed for an extended ferrofluid seal life, and particularly for use as an exclusion seal with a computer-disc-drive shaft. The ferrofluid seal apparatus provides for generally L-shaped pole pieces of the same or different width to form an interstage gap and a radial gap. In operation, the ferrofluid seal apparatus operates sequentially as a single-stage seal, and later, with the evaporation of the ferrofluid, a two-stage O-ring seal under each radial gap, thereafter a single-stage seal under one radial gap until seal failure, thereby providing a ferrofluid seal apparatus with an extended seal life.

80 The object of the present invention is to provide a new, low cost, self-activating seal of compact design which is easy to manufacture and assemble and to activate, and which has the characteristics of extended seal life.

90 The invention relates to a ferrofluid seal apparatus, and a method of manufacturing and use of such seal apparatus. In particular, the invention concerns a low cost, self-activating, extended life, compact ferrofluid exclusion seal apparatus particularly useful in sealing computer-disc-drive shaft spindles for extended time periods.

95 The self-activating ferrofluid seal apparatus of the invention comprises a ferrofluid seal which employs a very thin axially polarized magnet, typically not greater than about 25 mils in thickness and generally from about 15 to 25 mils in uniform thickness to define a 15 to 25 mil thick interstage gap between the inner surfaces of the pole pieces at the one end. The permanent magnet employed is a high energy product magnet such that the flux density of about 1,000 gauss or higher is produced in the air interstage gap between the inner surfaces of the pole pieces at the one end, so that the ferrofluid is retained within the air gap during shipment, and for example, may have an energy product of about 1.8×10^6 gauss-oersteds or greater. In addition, the self-activating ferrofluid seal apparatus employs a high magnetization ferrofluid of low volatility generally having a magnetization of about 200 gauss or more, for example, 200 to 400 gauss, and a viscosity ranging from about 50 to 400 cps at 27°C.

110 The ferrofluid seal apparatus thus defined and installed with radial gaps beneath the one, noncontacting end of the pole pieces ranging from about 2 to 10 mils, for example, 4 to 8 mils may have an interstage air gap between the pole pieces at the one end ranging from 15 to 25 mils.

125 Typically, the magnetically permeable pole pieces employed with the ferrofluid seal apparatus may be uniformly equal or be unequal in thickness and generally are pole pieces ranging from about 25 to 60 mils in thickness. In use, the ferrofluid seal apparatus generally includes an annular, nonmagnetic housing of aluminum or plastics material at

130

the other end of the pole pieces.

The ferrofluid seal apparatus of the present invention has a permanent magnet thickness far less than the standard ferrofluid seal, with the thickness 5 reduced to where the magnetically permeable pole-piece elements are separated by a gap in the range of about 10 to 25 mils, while the energy product of the permanent magnet is such that a high-flux density is produced in this gap to retain 10 the ferrofluid therein in a nonactivating condition. In operation when a magnetically permeable shaft element, such as a spindle shaft, is inserted within the ferrofluid seal apparatus, so that the radial gap between the shaft and the one end of the pole 15 piece is less than the interstage gap, for example, in the range of say 4 to 8 mils, the flux lines of the magnet change their flux path now to complete the magnetic circuit through the shaft so that the ferrofluid is drawn out of the interstage air gap between 20 the two pole-piece elements into the radial gap between the pole-piece elements at the one end to provide a single-stage seal with the ferrofluid seal having a general sectional inverted T-shape form, such as in the manner described in U.S. Patent No. 25 4,357,024. The ferrofluid seal of the present invention thus provides for a significant reduction in axial length of the seal which is most desirable with computer-disc-drive uses, is easy to manufacture and assemble, while the seal is less expensive than 30 the prior art self-activating seals because of the reduced thickness of the permanent magnet employed, while a longer seal life is obtained.

The magnetically permeable pole-piece elements employed may be typically straight-sided elements 35 of uniform thickness which define therebetween an air cavity in which the ferrofluid is retained at the one end of and between the pole pieces prior to insertion of the magnetically permeable shaft, for example, a nonactivated seal position. The ferrofluid is retained so that there is a slight bulge outwardly from the air cavity where the ferrofluid 40 follows the lines of magnetic flux. However, the ferrofluid so retained in the inner diameter is not generally in contact with the packaging or shipping material of the seal. Another advantage of the ferrofluid seal is that the ferrofluid so retained in the air space prior to activation also effectively seals 45 the air gap between the pole pieces and prevents loose microparticles in the air space from entering into the memory-disc area or the environment 50 which is to be protected by the exclusion seal prior to activation. Some customers, particularly in the computer-disc field, are concerned about microparticles in the air cavity between the pole pieces, so that the present invention provides for the ferrofluid in the nonactivating condition to seal in those 55 particles on the air cavity to provide a simple, effective, low cost ferrofluid seal.

In addition and optionally, ferrofluid may also be 60 retained within an air cavity at the other end of the pole-piece elements so as to provide a static ferrofluid seal rather than a seal occasioned by the outer housing and elastomeric O-ring seals surrounding the other end of the pole-piece elements. 65 The ferrofluid will also be retained in the annular

outer surface to form an effective ferrofluid static exclusion seal.

The invention will be described for the purposes of illustration only in connection with particular 70 embodiments, however, it is recognized that those persons skilled in the art may make various changes, additions, and improvements to the described embodiments without departing from the spirit and scope of the invention.

75 Specific embodiments of the present invention will now be described by way of example, and not by way of limitation, and to include both the apparatus and method aspects of the present invention, the description being given with reference to Figures 2 and 3 of the accompanying drawings in which:

Figure 1 is a schematic, illustrative, partial sectional view of a prior art two-stage ferrofluid exclusion seal;

85 *Figure 2* is a schematic, illustrative, partial sectional view of a self-acting ferrofluid seal of the present invention in a nonactivating condition; and

Figure 3 is a schematic, illustrative, partial sectional view of the self-activating seal of *Figure 2* 90 which has been activated by the insertion of a magnetically permeable shaft and placed in an activated sealing condition.

With reference now to the accompanying drawings, and first to *Figure 1*, this illustrates a standard, prior art ferrofluid exclusion seal apparatus 10 composed of a nonmagnetic housing 12, such as aluminum, and magnetically permeable pole pieces 14 and 16 on either side of an annular axially polarized permanent magnet 18. The housing is statically sealed about the outer or other ends of the pole pieces 14 and 16 by the use of O-ring seals, while there is a ring-like air cavity 20 between the housing 12 and the magnet 18. The seal apparatus 10 is shown in its activated form with a pair of ferrofluid O-ring seals 24 about the surface of a shaft 22 with an intervening air space 26. 105

In the seal apparatus 10 shown, the magnetically permeable pole pieces normally are uniformly equal and range from about 25 to 60 mils in thickness, while the permanent magnet generally ranges from about 50 mils to 150 mils in thickness. The permanent magnet 18 may be formed of a wide variety of materials such as Plastiform, ceramic or metal material, but generally with an energy product of less than 1.8×10^6 gauss-oersteds. 115 The ferrofluid 24 is typically a low-vapor-pressure synthetic hydrocarbon or ester-type ferrofluid having a magnetic saturation of about 100 to 400 gauss, and having a viscosity ranging from about 50 to 400 cps at 27°C. The shaft 22 employed is typically a rotary magnetically permeable spindle shaft, such as a computer shaft, with a radial gap of from about 2 to 10 mils, with the ferrofluid inserted by the customer into the radial gap after 125 insertion of the magnetically permeable shaft. The ferrofluid forms two separate O-ring seals about the surface of the shaft 22 illustrated by the dotted lines, while an air cavity 26 is formed between the pole pieces.

130 *Figure 2* shows a low cost, self-activating ferro-

fluid seal apparatus 30 of the present invention in a nonactivated state and contained in a nonmagnetic housing 32, such as of aluminum or plastics material, annular, magnetically permeable pole pieces 34 and 36 normally ranging from about 5 to 60 mils in thickness and a thin axially-polarized annular permanent magnet 38 having a thickness of 10 to 25 mils and an energy product of greater than about 1.8×10^6 gauss-oersteds. Typically, the magnet should be formed of a "Plastiform" material (of 3M Company) or of a molded material, such as an elastomeric material, which may be machined or otherwise formed to the thinness required. While other permanent magnet materials may be employed, such as ceramic or metal or even polymeric magnets such as nylon, these and other magnet materials are often difficult to prepare, machine, or to manufacture in the thin thickness form required by the present invention.

Further, where any permanent magnet material used tends to be porous so as to take up ferrofluid, optionally the magnet material should be coated with a thin exterior coating of a nonmagnetic material, such as a plastics material like a polyurethane or polyvinyl chloride, in order to seal the outer surface of the magnet to reduce the porosity of the magnet material for the ferrofluid.

At the one end of the pole pieces 34 and 36 and in the interstage air gap provided therebetween the ferrofluid 46 is retained in a nonsealing position through the magnetic-flux lines of the magnet. The ferrofluid curves slightly outward from the end of each of the pole pieces 34 and 36, while the other inner end of the ferrofluid is in a slight meniscus form as illustrated so that the ferrofluid conforms generally to the magnetic-flux lines of the permanent magnet 38. At the other end at the ferrofluid seal 30 there is a ring-like air cavity 48 which has been sealed by the use of a ferrofluid 40 shown at the one end of the outer cavity and against the nonmagnetic housing 32 so as to provide for an effective static seal. This ferrofluid, in the static seal in position, does not move significantly with the insertion of the shaft at the other end, since there is little or only a slight change in the lines of flux. As illustrated, any microparticles within the air cavity 50 between the nonactivated ferrofluid 46 and the inner surface of the annular permanent magnet 38 are not released into the atmosphere on activation of the seal, since the ferrofluid seals the air cavity in the nonactivating and activating condition.

Figure 3 shows the low cost, self-activating seal of the present invention in the activated state wherein a magnetically permeable shaft 42 has been inserted, and wherein the ferrofluid 46 in the activated state has now moved into the radial gap 44 of 4 to 8 mils to form a generally sectional T-shaped single-stage ferrofluid seal. This exclusion seal of Figure 3 has been found to possess adequate pressure capacities of greater than 5 inches of water, not to permit the release of microparticles in the air cavity 50, and the axial length of the seal is reduced making for a more compact design.

The employment of uniform smooth-sided pole-

piece elements and the use of a reduced thickness of a magnet provides for a low cost of manufacturing, easy assembly, as well as easy activation of the seal. The configuration of the T-shape ferrofluid exclusion seal provides for longer seal life through the progressive movement of the seal from the single-stage to double seal to single-stage form. The ferrofluid employed is a low-vapor-pressure synthetic hydrocarbon or ester ferrofluid having a magnetic saturation of about 200 to 400 gauss and a viscosity of 50 to 400 cps at 27°C. The radial gap on the magnetically permeable shaft on the one end of the pole pieces 34 and 36 is about 4 to 8 mils, while the air gap between the pole pieces range from about 15 to 25 mils so that the radial gap is less than the interstage gap which is typically two to three times or more than the radial gap. The employment of the ferrofluid 40 at the outer end of the magnet in the outer cavity 48 eliminates the use of static O-ring seal and helps to prevent flux leakage out of the outer diameter of the ferrofluid seal and through the housing.

CLAIMS

1. Ferrofluid seal apparatus comprising:
 - an annular, permanent magnet to surround a magnetically permeable shaft element whose surface is to be sealed;
 - first and second annular, magnetically permeable spaced apart pole-piece elements each having a one and other end, the one end of each of the first and second pole-piece elements to extend into a close noncontacting relationship with the surface of the shaft element to form a first and second radial gaps therewith, the other end of the first and second pole pieces to be placed in a magnetic-flux relationship with the permanent magnet to form an air cavity between the first and second pole pieces, and ferrofluid to be retained in the first and second radial gaps by the magnetic flux of the permanent magnet on the insertion of the shaft element into the seal apparatus to form a ferrofluid liquid O-ring seal about the surface of the shaft element;
 - the permanent magnet having a thickness of up to about 25 mils, forming an interstage air gap between the one ends of the first and second pole pieces and an energy product of at least about 1.8×10^6 gauss-oersteds or more;
 - the ferrofluid having a magnetic saturation of at least 200 gauss and being retained in the interstage air gap between the first and second pole pieces in the nonactivated condition of the apparatus and, on the insertion of a magnetically permeable shaft element into the ferrofluid seal apparatus, the ferrofluid moving to form a single-stage ferrofluid seal about the surface of the shaft element.
2. The seal apparatus of claim 1 wherein the permanent magnet has a thickness ranging from about 15 to 25 mils.
3. The seal apparatus of claim 1 or 2 wherein the flux density in the interstage air gap is about 1,000 gauss or higher.
4. The seal apparatus of any preceding claim wherein the first and second pole pieces have a

thickness of from about 25 to 60 mils.

5. The seal apparatus of any preceding claim wherein the permanent magnet is composed of a polymeric machinable permanent magnet material.

6. The seal apparatus of any preceding claim wherein the permanent magnet has a thin, non-magnetic coating thereon to reduce the porosity of the permanent magnet material.

7. The seal apparatus of any preceding claim wherein the ferrofluid has a magnetic saturation of about 200 to 400 gauss and a viscosity ranging from about 50 to 400 cps at 27°C.

8. The seal apparatus of any preceding claim wherein the first and second pole pieces are of substantially equal and uniform thickness.

9. The seal apparatus of any preceding claim which includes a nonmagnetically permeable housing about the other end of the pole pieces.

10. The seal apparatus of claim 9 wherein there is a second annular air gap formed between the housing and the other end of the first and second pole pieces and which includes ferrofluid within the second air gap and retained in position to form a ferrofluid static seal with the housing.

11. A ferrofluid exclusion seal system which comprises the ferrofluid seal apparatus of any preceding claim and which includes a magnetically permeable shaft element within the seal apparatus, the ferrofluid forming a single-stage ferrofluid liquid O-ring seal about the surface of the shaft element.

12. The system of claim 11 wherein the single-stage ferrofluid liquid O-ring seal is of T-shape in cross-section.

13. The system of claim 11 or 12 wherein the first and second radial gap ranges from about 4 to 8 mils and wherein the interstage air gap ranges from about 15 to 25 mils.

14. The system of claim 11, 12 or 13 wherein the magnetically permeable shaft comprises a computer-disc-drive shaft and the exclusion seal separates a memory-disc area from a contaminating area environment.

15. A method for providing a self-activating ferrofluid exclusion seal system about a magnetically permeable shaft comprising retaining a defined quantity of ferrofluid in an interstage air gap between and at the one ends of a pair of spaced apart annular pole pieces having generally uniform sides with the other ends of the pole pieces in a magnetic-flux relationship with an annular, permanent magnet, the ferrofluid being retained in the interstage gap by the magnetic flux of the permanent magnet and the ferrofluid extending only slightly outward of the one ends of the pole pieces to form a nonactivated ferrofluid seal capable of shipment with the ferrofluid retained in position in the interstage gap and then forming a ferrofluid O-ring seal about the surface of a magnetically permeable shaft by inserting the shaft within the annular pair of pole pieces, the shaft then defining a sealed gap at the one end of the pole pieces less than the interstage air gap, the ferrofluid, on insertion of the shaft being transformed from a nonactivated to an activated seal, the ferrofluid forming a

generally T-shaped sectional ferrofluid O-ring seal about the surface of the shaft in the interstage and sealed gaps.

16. The method of claim 15 which includes forming an interstage gap of about 15 to 25 mils and a radial gap of 4 to 8 mils.

17. The method of claim 15 or 16 wherein the ferrofluid moves from a nonactivated seal wherein the ferrofluid has a generally cylindrical sectional shape form with slightly arcuate ends, to an activated seal wherein the ferrofluid has a generally T-shaped sectional form.

18. Ferrofluid seal apparatus as claimed in claim 1, substantially as any one of the embodiments hereinbefore described with reference to Figure 2 of the accompanying drawings.

19. A method for providing a self activating ferrofluid exclusion seal system substantially as hereinbefore described with reference to the accompanying drawings.

20. A ferrofluid exclusion seal system substantially as hereinbefore described with reference to, and as shown in, Figure 3 of the accompanying drawings.

Printed in the UK for HMSO, D8818935, 1/86, 7102.
Published by The Patent Office, 25 Southampton Buildings, London, WC2A 1AY, from which copies may be obtained.