

[54] ICE HOCKEY STICK BLADE STRUCTURE

[75] Inventor: David A. Diederich, Chaska, Minn.

[73] Assignee: The Northland Group, Inc., Chaska, Minn.

[21] Appl. No.: 914,425

[22] Filed: Jun. 12, 1978

Related U.S. Application Data

[62] Division of Ser. No. 742,017, Nov. 15, 1976, Pat. No. 4,134,587.

[51] Int. Cl.² A63B 59/12

[52] U.S. Cl. 273/67 A

[58] Field of Search 273/67 R, 67 A, 67 D,
273/73 F, DIG. 7, DIG. 23

[56] References Cited

U.S. PATENT DOCUMENTS

3,313,541	4/1967	Benkoczy et al.	273/DIG. 7
3,691,000	9/1972	Kalnin	273/DIG. 7
3,813,098	5/1974	Fischer et al.	273/67 A X
3,982,760	9/1976	Tiltola	273/67 A
3,993,308	11/1976	Jenks	273/73 F
4,052,499	10/1977	Goupil et al.	273/67 A X

FOREIGN PATENT DOCUMENTS

591454	1/1960	Canada	273/67 A
925530	5/1973	Canada	273/67 A
933965	9/1973	Canada	273/67 A
2353843	10/1974	Fed. Rep. of Germany	273/67 A
42515	4/1970	Finland	273/67 A
60203	11/1947	Netherlands	273/67 A
90729	1/1958	Norway	273/67 A
618310	2/1949	United Kingdom	273/67 A
744778	2/1956	United Kingdom	273/67 D

OTHER PUBLICATIONS

"The Sporting Goods Dealer"; Dec. 1973; p. 162.
"The Sporting Goods Dealer"; Mar. 1976; p. 60.

Primary Examiner—Richard J. Apley
Attorney, Agent, or Firm—Burd, Braddock & Bartz

[57] ABSTRACT

An ice hockey stick having an elongated handle attached to a blade. The handle has a solid lightweight and flexible wood body reinforced with plastic sheet members provided with longitudinally oriented glass fibers. The blade has a rocker shaped bottom with a heel carrying an epoxy wear strip. The blade is reinforced with glass fiber fabric impregnated with a resin plastic.

19 Claims, 9 Drawing Figures

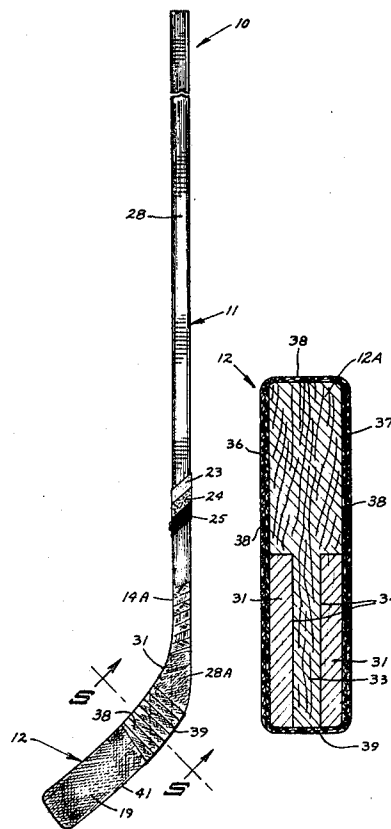

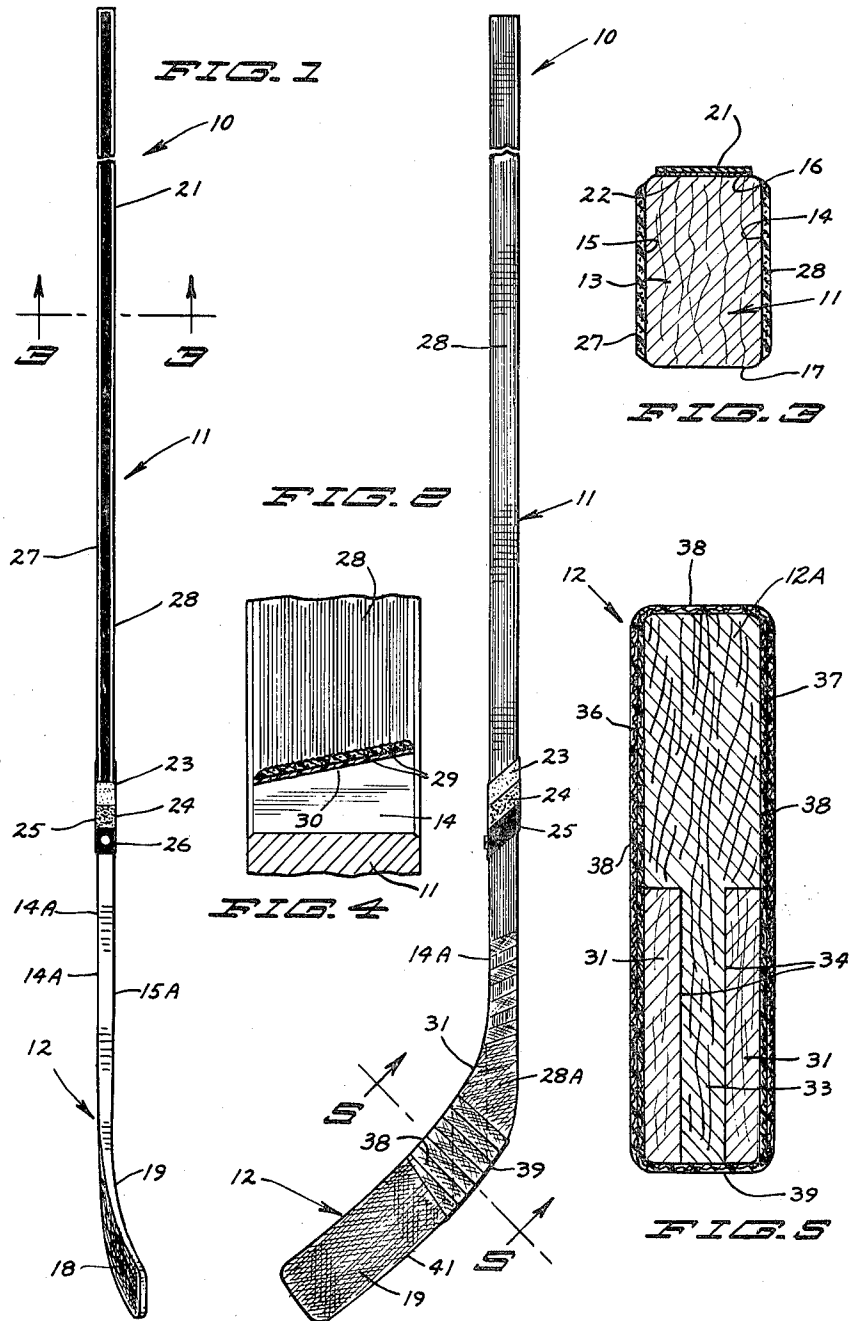

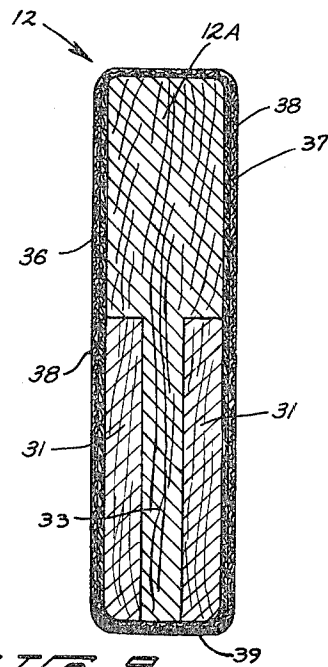
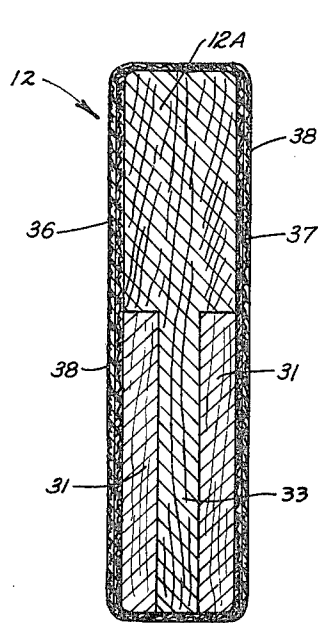
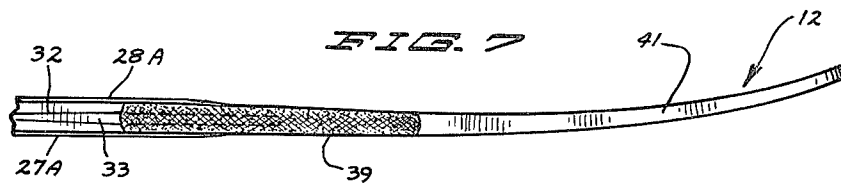
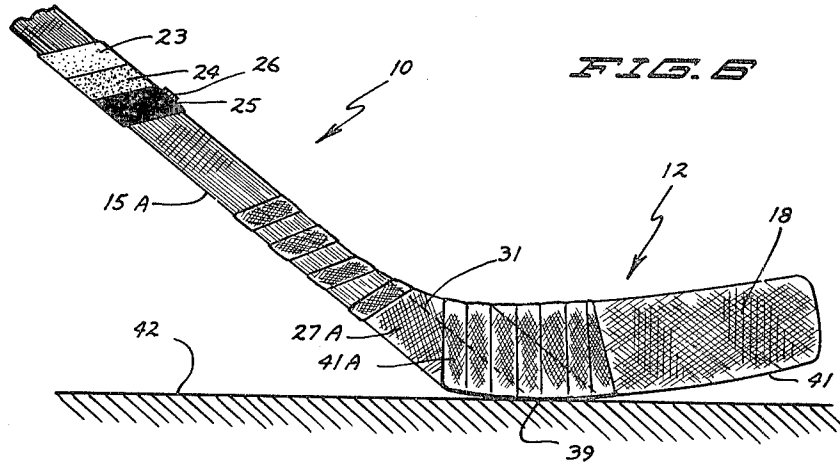

ICE HOCKEY STICK BLADE STRUCTURE

This is a division, of application Ser. No. 742,017 filed Nov. 15, 1976, now U.S. Pat. No. 4,134,587.

BACKGROUND OF THE INVENTION

White northern ash is used to make lightweight ice hockey sticks. This wood is resistant to impact breakage and is sufficiently flexible and light. The weight of raw white northern ash used to make the stick varies. The supply of white northern ash is limited, resulting in an inadequate supply of ash stick handles having a finished weight of under 20 oz. It has also been found that the heel portion of the rocker shaped bottom edge of the blade of the hockey stick is the first part of the stick to deteriorate and show signs of wear in use.

Hockey sticks are disclosed in the following patents:

- U.S. Pat. No. 1,821,889 Glahe Sept. 1, 1931
- U.S. Pat. No. 2,023,728 Evernden Dec. 10, 1935
- U.S. Pat. No. 2,040,132 Hall May 12, 1936
- U.S. Pat. No. 2,260,218 Evernden Oct. 21, 1941
- U.S. Pat. No. 2,334,860 Berger Nov. 23, 1943
- U.S. Pat. No. 2,504,242 Yerger Apr. 18, 1950
- U.S. Pat. No. 2,569,395 Zupanick Sept. 25, 1951
- U.S. Pat. No. 2,730,367 Bublik Jan. 10, 1956
- U.S. Pat. No. 3,353,826 Traverse Nov. 21, 1967
- U.S. Pat. No. 3,458,194 Coles July 29, 1969
- U.S. Pat. No. 3,489,412 Franck et al Jan. 13, 1970
- U.S. Pat. No. 3,533,623 Dumont Oct. 13, 1970
- U.S. Pat. No. 3,677,542 Michaud July 18, 1972
- U.S. Pat. No. 3,961,790 Milligan June 8, 1976
- Canadian Pat. No. 459,578 Boulanger Sept. 13, 1949
- Canadian Pat. No. 463,938 Berger Mar. 28, 1950
- Canadian Pat. No. 591,454 Veillet Jan. 26, 1960
- Canadian Pat. No. 896,690 Peillex Mar. 28, 1972
- Canadian Pat. No. 906,020 Michaud July 25, 1972
- Canadian Pat. No. 925,530 Schumph May 1, 1973
- Norwegian Pat. No. 90,729 Skifabrikk Nov. 9, 1957

SUMMARY OF THE INVENTION

The invention is directed to a stick known as an ice hockey stick having an elongated linear handle attached to a laterally projected blade. The handle comprises an elongated linear body having a generally rectangular cross section and opposite linear outside surfaces. Reinforcing sheet members are secured with an adhesive to the opposite outside surfaces of the body. Each sheet member has a plurality of reinforcing fibers, as glass fibers, oriented along the longitudinal length of the sheet members. The glass fibers are impregnated in a rigid plastic resin. The sheet members are pultruded glass fiber members. The body can be made of numerous lightweight and flexible woods including but not limited to ash, aspen, basswood, sitka spruce and poplar. The reinforcing sheet members resist the breakage of the wood body and provide for a stick handle that is consistent in weight and has memory flexibility. Lightweight woods, as basswood, sitka spruce and poplar, heretofore not usable for hockey sticks because of their low strength and flexibility, can now be used with the reinforcing side sheet members.

The lower end of the handle has a longitudinal mid-groove accommodating a flat tongue portion of the blade. Bonding means secure the tongue portion of the blade and handle together. A first reinforcing fabric is located along adjacent sides of the blade and attached thereto with a plastic resin. A second reinforcing fabric

is wrapped around the blade and lower end of the handle. An elongated plastic wear strip, as epoxy, extends along the heel of the lower rocker edge of the blade. The reinforcing sheet members on opposite sides of the handle extend downwardly to the plastic wear strip.

An object of the invention is to provide a hockey stick handle with reinforcing side sheet members bonded to opposite sides of a lightweight and flexible wood body secured to a blade having a wear strip located along the heel of the blade. A further object of the invention is to provide a hockey stick with a lightweight handle that can be made from numerous types of wood reinforced with sheet members having longitudinally oriented glass fibers impregnated in a plastic resin bonded to opposite sides of the handle in conjunction with a blade reinforced with reinforcing fabric impregnated in a plastic resin. A further object of the invention is to provide a lightweight hockey stick that has an attained weight of less than 20 oz., and is flexible, durable and sturdy in use. Yet another object of the invention is to provide an improved method of making a lightweight and flexible hockey stick.

IN THE DRAWINGS

FIG. 1 is a front elevational view of an ice hockey stick embodying the features of the invention;

FIG. 2 is a side elevational view of FIG. 1;

FIG. 3 is an enlarged sectional view taken along the line 3—3 of FIG. 1;

FIG. 4 is an enlarged fragmentary perspective view of a side of the handle of the hockey stick of FIG. 2;

FIG. 5 is an enlarged sectional view taken along the line 5—5 of FIG. 2;

FIG. 6 is an enlarged side elevational view of the lower or blade end of the ice hockey stick of FIG. 1;

FIG. 7 is an enlarged bottom plan view of FIG. 6;

FIG. 8 is a sectional view similar to FIG. 5 showing the blade wrapped with two layers of glass fiber material impregnated with a plastic resin; and

FIG. 9 is a sectional view similar to FIG. 8 showing an epoxy wear strip impregnated in the glass fiber material along the heel of the blade.

DESCRIPTION OF PREFERRED EMBODIMENT OF INVENTION

Referring to FIGS. 1 and 2, there is shown an ice hockey stick, indicated generally at 10, having an elongated longitudinal linear handle 11 attached at its lower end to a curved blade 12. The curvature of blade 12 can be left or right, and the amount of curvature or hook can vary. Blade 12 can be straight or neutral by being located in the longitudinal plane of handle 11. The regulation limits of the curvature of the blades are disclosed in U.S. Pat. No. 3,902,250.

Handle 11 has a wood body 13. The grain of the wood of body 13 extends along the longitudinal length of the body. The body 13 shown in FIG. 3 is a solid wood. The wood can be hickory, ash, pine, basswood, sitka spruce, aspen or poplar. Other types of woods can be used for the body of the handle. The wood is flexible and light in weight. The specified species will result in a finished stick with a weight of 20 or less ounces.

Body 13 has a rectangular cross section with flat linear opposite outside surfaces 14 and 15, a flat linear front outside surface 16, and a flat back outside surface 17. Surfaces 14, 15, 16 and 17 extend the full length of handle 11. The lower end of handle 11 has downwardly and inwardly converging sides 14A and 15A joined

with and coextensive with opposite sides 18 and 19 of blade 12.

An ornamental elongated strip or ribbon 21 is attached with adhesive 22 to the front surface 16. Strip 21 has a width slightly less than the width of surface 16. As shown in FIG. 1, opposite linear line portions of surface 16 project laterally from opposite sides of strip 21. Strip 21 is shown in FIG. 1 as a solid black surface. An example of this surface is a plastic solid black tape secured with adhesive to the body surface 16. Tapes of other colors, as red, blue, yellow and green and the like, can be used in association with handle 11. Strip 21 can be paint, a plastic skin, a burned surface or like colored indicia on the front surface 16 of handle 11.

Three side-by-side bands, bars or chevrons 23, 24 and 25 of contrasting colors surround the lower end of handle 11 at the end portion of strip 21. The bands 23, 24 and 25 are angularly inclined upwardly from the front surface 16 to back surface 17 and are generally parallel to the longitudinal or length dimension of the top of blade 12. Each band 23, 24 and 25 has a width that is wider than the width of strip 21. Returning to FIG. 1, a small circle or colored dot 26 is located on the front of band 25. Dot 26 has a color, as red, that contrasts with the colors of band 25.

An example of the contrasting colors of bands 23, 24 and 25 is as follows: band 23 is a grey tape; band 24 is a silver tape; and band 25 is a black tape. Each band surrounds the handle and is secured to the surfaces 14, 15, 16 and 17 with an adhesive. Other colored bands, including black, white and black; red, white and red; and red, white and blue, can be used for bands 23, 24 and 25. Bands 23, 24 and 25 can be paint, plastic skin, burned surfaces and like colored indicia. Hockey sticks having a front strip or angled or inclined bars are disclosed in co-pending U.S. Design application Ser. No. 623,465 filed Oct. 17, 1975, now U.S. Pat. No. Des. 244,220 and Canadian Industrial Design No. 41148.

Referring to FIGS. 3 and 4, wood body 13 of handle 11 is reinforced with side sheet members 27 and 28. Sheet members 27 and 28 have longitudinally oriented linear fibers 29 embedded within a plastic resin. Fibers 29 are longitudinal linear glass fibers embedded within a rigid elastic plastic resin material. Layers of adhesive 30 secure the entire inside surface of the sheet member 27 to side 13 and the entire inside surface of sheet member 28 to side 14. Sheet members 27 and 28 are pultruded plastic having glass fibers. The glass fibers are all longitudinally oriented along the length of the sheet members. The glass fibers can be glass material or materials compounded with graphite. The fibers are embedded in a yieldable plastic base or matrix. The side sheet members 27 and 28 increase the memory of handle 11 without breaking the handle. In other words, handle 11 will return to its original shape or straight plane after being subjected to a bending force, as a hard slap shot. This increases the accuracy of the shot and the speed of the puck. Other types of linear fibers, as polyester and nylon fibers, can be used to reinforce the sheet members 27 and 28. Also, high modulus fibers, as carbon, graphite, boron, and polyamide can be incorporated in the resin base of sheet members 27 and 28.

A rigid joint structure connects the lower end of handle 11 to the inner end of blade 12. The joint structure includes a glue block 31 secured with a bonding material or glue or the like to the front side of the lower end of the handle 11. Glue block 31 and the lower end of handle 11 has a V-shaped groove 32 along a longitu-

dinal axis of the block and handle. The groove 32 is shown in FIG. 7. Blade 12 has a complementary V-shaped tongue or rib 33 located within groove 32. Bonding material 34 secures the adjacent surfaces of tongue, glue block and lower end of handle 11 together to form a rigid joint structure.

Blade 12 has a wood core or body 12A that is reinforced with a first sheet of glass fabric 36 located on side 18 and a second sheet of glass fabric 37 located adjacent the side 19 of blade 12. A ribbon or wrapping of glass fabric 38 is located around the inner portion of blade 12 and extends upwardly around the lower end of handle 11. The fabric 36, 37 and 38 is a woven glass fiber fabric. A plastic thermosetting resin such as polyester is impregnated in the fabric and bonds the fabric to the opposite sides of the blade 12 and the lower end of handle 11 and the sheet members 27 and 28. The fabric and plastic resin is pressed in firm contact with the sides of the blade 12.

As shown in FIGS. 6 and 7, an elongated wear strip 39 is located along the lower edge of rear or heel portion 41A of the bottom of blade 12. Blade 12 has a rocker or convex shaped bottom edge 41 that engages the ice 42 along the heel portion 41A. Wear strip 39 is a bead of plastic material such as a tough epoxy plastic impregnated into the lower edge of the ribbon of fabric 38 and bonded to the lower edge of heel portion 41A of blade 12. Wear strip 39 functions as a shock and wear absorbing bead as it rides on the surface of ice 42 and it takes the abuse of the movement and pounding of the stick on the ice. Strip 39 also absorbs impact forces subjected to the heel portion of the stick when the player takes a slap shot. Wear strip 39 minimizes the shattering and breaking of the stick in the area of the heel, thereby adding to the durability and longevity of the stick. An example of the epoxy resin material is bisphenol-A epichlorohydrin resin. Other types of epoxy resins can be used. The epoxy resin has a high degree of solvent resistance, adhesion to wood and fiber substrates, and good impact resistance and flexibility.

Hockey stick 10 is manufactured from the raw wood product comprising an elongated handle body, a glue block and a flat wood blade. The body and block are glued together. Groove 32 is placed in the lower end of the body and block with a rotating circular cutting tool. One end of blade 12 is cut to form the tongue portion 33. The blade 12 is secured to the handle and block by placing tongue portion 33 in groove 32 and securing or bonding these parts together with glue or suitable bonding material. A circular cutting tool is used to shape the blade and the lower end of the handle to outline shape. The handle and blade is then sanded to the finished shape.

The elongated sheet members 27 and 28 are secured with the adhesive 30 to the opposite sides of the handle. The sheet members 27 and 28 have lower sections 27A and 28A that extend all the way down to the lower edge of the heel of blade 12.

Fabric sheets 36 and 37 are placed adjacent opposite sides of the blade over the lower ends of the sheet members 27 and 28 and extend a short distance up the handle 11. A plastic resin is then applied to fabric sheets 36 and 37. Ribbon 38 is a tape of glass fiber fabric that is wrapped around the rear portion of the blade and over the heel section 41A. The plastic resin being uncured and in a semi-liquid state is absorbed by the fabric sheets 36 and 37 and the ribbon of fabric 38. The plastic resin is not placed on the heel section of the blade. The ribbon

38 of fabric extended along the rocker edge 41 is embedded in the epoxy strip 39. Epoxy material is applied onto the rocket edge to make the strip 39. Strip 39 extends approximately one-half the distance of the bottom rocker edge 41 of blade 12.

The ornamental black strip 21 is applied to the front surface 16 of handle 11. The angled triad of bars 23, 24 and 25 are then secured to the handle adjacent the lower end of strip 21. Additional designs and trademarks are applied to the handle before the stick is packaged for shipment to the consumer.

While there has been shown and described a preferred embodiment of an ice hockey stick and method of making the ice hockey stick, it is understood that changes in the structure and materials of the ice hockey stick and the method of making the ice hockey stick can be made by those skilled in the art without departing from the invention. The invention is defined in the following claims.

The embodiments of the invention in which an exclusive property or privilege is claimed are defined as follows:

1. An ice hockey stick comprising: an elongated linear handle having a body with opposite outside side surfaces, a blue block secured to the lower end of the body, said handle and glue block having a lower end with a longitudinal V groove, a blade having opposite sides, an inner end, an outer end, and a convex curved lower edge extended from the inner end to the outer end thereof, said inner end having a generally V-shaped tongue located in said longitudinal V groove, bonding means securing the tongue to the lower end of the handle and the glue block, a first reinforcing fabric located adjacent opposite sides of the blade, a second reinforcing fabric wound around the blade, the convex lower edge of the blade, and first reinforcing fabric located adjacent opposite sides of the blade; a plastic resin covering the opposite sides of the blade and the first and second reinforcing fabric located adjacent the opposite sides of the blade, at least a portion of the lower edge of the blade covered by the second fabric and the second fabric adjacent said portion of the lower edge being substantially devoid of said plastic resin, and a plastic wear strip embedded in the second reinforcing fabric adjacent said portion of the lower edge of the blade and bonded to said portion of the lower edge of the blade, said wear strip comprising an elongated wear resistant bead adapted to engage the surface of the ice.

2. The stick of claim 1 wherein: the first reinforcing fabric comprises sheets of glass fabric located adjacent the opposite sides of the blade.

3. The stick of claim 2 wherein: the second reinforcing fabric is a glass fabric wound around the first fabric, blade, and lower edge of the blade.

4. The stick of claim 1 wherein: said portion of the lower edge of the blade extends from the inner end toward the outer end of the lower edge of the blade.

5. The stick of claim 4 wherein: the wear strip includes an epoxy material.

6. The stick of claim 1 wherein: said portion of the lower edge of the blade extends from the lower end of the handle and glue block to about the mid-section of the blade, said plastic wear strip comprising a continuous bead extended along said portion of the lower edge of the handle, glue block and blade and bonded thereto.

7. The stick of claim 6 wherein: the first reinforcing fabric comprises sheets of glass fabric located adjacent the opposite sides of the blade, and the second fabric is

a glass fabric wound around the first fabric, blade, and lower edge of the blade.

8. An ice hockey stick comprising: an elongated linear handle having a body, a blade having sides, an inner end, and an outer end, and a convex curved lower edge extended from the inner end to the outer end thereof, said blade and body having cooperating portions secured together to attach the blade to the body, reinforcing fabric means located adjacent opposite sides of the blade, said reinforcing fabric means having a portion covering an inner portion of the lower edge of the blade, a plastic resin covering the sides of the blade and the fabric means located adjacent opposite sides of the blade to secure the fabric means to the sides of the blade, said portion of the fabric means covering an inner portion of the lower edge of the blade being substantially devoid of resin, and wear strip means of wear resistant material embedded in the portion of the fabric means covering an inner portion of the lower edge of the blade and secured to the inner portion of the lower edge of the blade.

9. The stick of claim 8 wherein: the reinforcing fabric means comprise sheets of glass fabric located adjacent opposite sides of the blade and glass fabric wound around the sheets of glass fabric, blade, and lower edge of the blade.

10. The stick of claim 9 wherein: the wear strip means includes an epoxy material.

11. The stick of claim 8 wherein: the plastic wear strip means extends from the inner end toward the outer end of the lower edge of the blade.

12. The stick of claim 8 wherein: the wear strip means includes an epoxy material.

13. The stick of claim 8 wherein: the reinforcing fabric means comprises a first reinforcing fabric located adjacent opposite sides of the blade, and a second reinforcing fabric wound around the blade, first reinforcing fabric and a portion of the lower edge of the blade, said wear strip means including a continuous bead containing epoxy material adapted to engage the surface of the ice.

14. The blade structure of a hockey stick having an elongated linear handle having a lower end comprising: a blade having sides, an inner end, an outer end, and a lower edge, said blade and lower end of the handle having cooperating portions secured together to attach the inner end of the blade to the lower end of the handle, reinforcing fabric means located adjacent opposite sides of the blade and lower end of the handle, said reinforcing fabric means having a portion covering an inner portion of the lower edge of the blade, a plastic resin covering the sides of the blade, and fabric means located adjacent said sides of the blade to secure the fabric means thereto, said portion of the fabric means covering an inner portion of the lower edge of the blade being substantially devoid of resin, and a wear strip of wear resistant material embedded in the portion of the fabric means covering an inner portion of the lower edge of the blade and secured to the lower edge of the blade.

15. The stick of claim 14 wherein: said blade has a convex curved lower edge extended from the inner end to the outer end thereof, said wear strip being located along the inner end of said convex curved lower edge.

16. The stick of claim 15 wherein: the wear strip includes an epoxy material bonded to the lower edge of the blade.

7

17. The stick of claim 16 wherein: the reinforcing fabric means comprises a first reinforcing fabric located adjacent opposite sides of the blade, and a second reinforcing fabric located around the first fabric, blade, and inner portion of the lower edge of the blade.

18. The stick of claim 16 wherein: the first reinforcing fabric comprises sheets of glass fabric located adjacent opposite sides of the blade, and the second reinforcing

8

fabric is a glass fabric wound around the first reinforcing fabric, blade, and lower edge of the blade.

19. The stick of claim 14 wherein: the wear strip includes an epoxy material bonded to the lower edge of the blade, said wear strip forming a continuous bead adapted to engage the surface of the ice.

* * * * *

10

15

20

25

30

35

40

45

50

55

60

65

UNITED STATES PATENT AND TRADEMARK OFFICE
CERTIFICATE OF CORRECTION

PATENT NO. : 4,172,594
DATED : October 30, 1979
INVENTOR(S) : David A. Diederich

It is certified that error appears in the above-identified patent and that said Letters Patent are hereby corrected as shown below:

Column 5, line 3, "rocket" should be --rocker--.

Column 6, line 33, "expoxy" should be --epoxy--.

Signed and Sealed this

Fifth **Day of** *February* 1980

[SEAL]

Attest:

SIDNEY A. DIAMOND

Attesting Officer

Commissioner of Patents and Trademarks