

T. J. NASH.
GRIDDLE.

APPLICATION FILED JULY 28, 1914. RENEWED SEPT. 27, 1916.

1,204,682.

Patented Nov. 14, 1916.

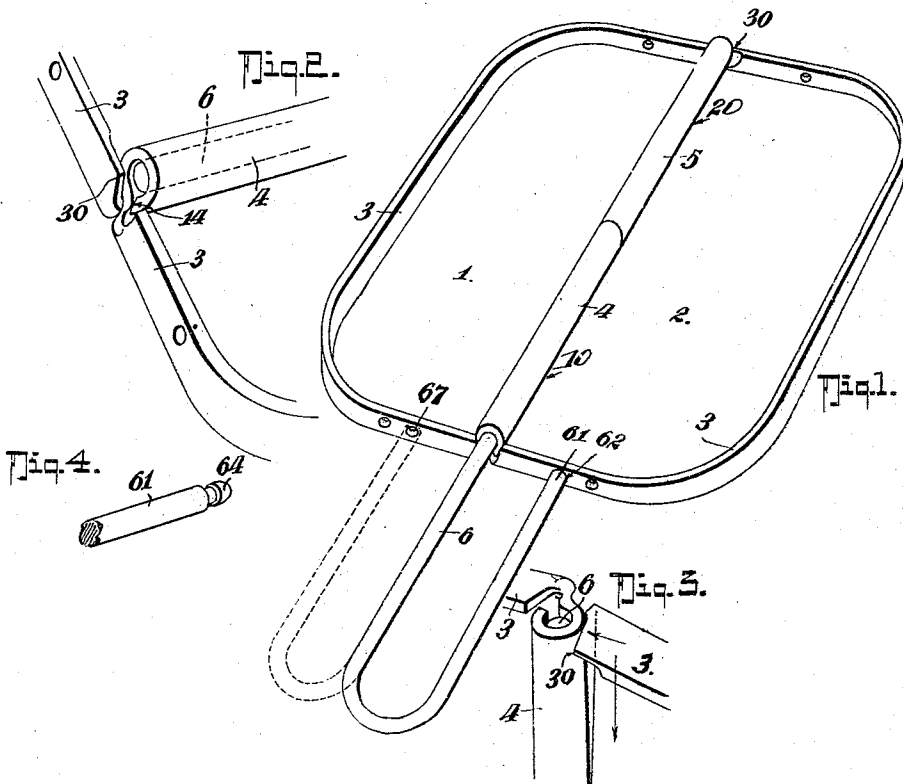

WITNESSES:

John E. Schrott
May E. Immich

INVENTOR

Thomas J. Nash
BY
Fred G. DeLerick
ATTORNEYS.

UNITED STATES PATENT OFFICE.

THOMAS J. NASH, OF LINCOLN, NEBRASKA, ASSIGNOR TO AMERICAN ALUMINUM WARE COMPANY, OF LINCOLN, NEBRASKA.

GRIDDLE.

1,204,682.

Specification of Letters Patent.

Patented Nov. 14, 1916.

Application filed July 28, 1914, Serial No. 853,620.

Renewed September 27, 1916. Serial No. 122,557.

To all whom it may concern:

Be it known that I, THOMAS J. NASH, residing at Lincoln, in the county of Lancaster and State of Nebraska, have invented
5 a new and Improved Griddle, of which the following is a specification.

This invention relates to improvements in griddles and it primarily has for its object to provide a folding griddle of a simple and economical construction and adapted for being conveniently handled for turning pan-cakes and the like from one side to the other.
10

Another object of my invention is to provide a device of the character stated that embodies two sections hingedly joined and closable upon each other, and the two sections, together, with a handle member that coöperates therewith, are operatively joined
15 without the necessity of using rivets, screws and the like.
20

With other objects that will appear, my invention embodies the peculiar construction and arrangement of the parts that constitute my improved griddle hereinafter described, specifically pointed out in the appended claims and illustrated in the accompanying drawing, in which:
25

Figure 1 is a perspective view illustrative of the invention. Fig. 2 is a detail perspective view showing means for holding the hinge sections from endwise separation. Fig. 3 is a detail perspective view of a portion of the two sections and the same illustrates the "spring" of the hinge connection when fitting the two sections together. Fig. 4 is a detail perspective view of the notch engaging end of the handle shown in Fig. 1.
30

In carrying out my present invention, I provide a pair of similar griddle sections 1 and 2, stamped or otherwise formed of sheet metal, preferably aluminum. The upper surface of each griddle section is formed with a rim flange 3 that is bent upwardly, approximately at right angles to the face of the griddle and the said rims serve to retain the grease within the griddle and also keep the article being cooked in proper position. The griddle sections have outer rounded edges to conform to the shape of the pan-cake. Each of the sections 1—2 has its inner or straight edge formed with an extension 10—20, indicated by dotted lines in Fig. 1, and the said extensions in the manufacture of my improved griddle are
40
45
50
55

turned up to form tubular hinge members 4—5, which members, when the two sections are assembled, form a central tubular axial connection that extends the full length of the griddle and forms, as it were, a socket for receiving a handle member 6, in the nature of a stout rod that extends through the said socket.
60

In the manufacture of my improved griddle, the tubular hinge portion integral with the section 1 is preferably formed over a mandrel, whereas the tubular portion of the section 2 is formed over the handle stem or rod. The handle may consist of a spring rod 6 whose outer or handle portion is bent back upon itself to form a loop shaped hand-hold, the free end 61 of which, when slipping the handle into operative position within the tubular hinged members, is sprung into and through an aperture 62 in the rim flange 3.
65
70
75

The free end 61 of the handle member has a notched or button end 64 which springs into a locked engagement with the edge of the aperture 62 in which it is inserted. The end 61 forms the means for locking the section 2 to turn with the handle and section shown in Fig. 1, the rim 3 of the section 1 is also provided with an aperture 67 to provide a means for receiving the handle end 64 to connect the handle with the section 1 when it is desired to swing that section over.
80
85

At the handle end of the rod 6, the inner end of the rim or flange 3 on the section 1 is curved and is so shaped that it can freely slide over the tubular hinge member on the opposing section 2. At the other or outer end of the handle rod, the rim flange 3 of the two sections is provided with a portion 30 that overlaps the outer edge of the adjacent tubular hinge member, the purpose of which is to provide a simple and inexpensive means for holding the two sections interlocked and against accidental endwise separation when the parts are assembled for use.
90
95
100

In baking pan-cakes, the batter is put in that section of the griddle in which the handle is attached and when the cake is to be turned over, the other section is allowed to rest upon the stove, and by turning the handle to the left, the section 2 turns with it and the cake is turned over into the other section.
105
110

From the foregoing description taken in connection with the accompanying drawing, the complete operation and advantages of the invention will be clear.

5 What I claim is:

1. In a griddle, a pair of like griddle sections, each of which includes a tubular hinge section at the inner edge thereof, the said tubular sections being in longitudinal alinement, a handle which includes a rod that extends through the tubular hinge sections, means for fixedly connecting the handle with one of the said sections to turn the section as the handle turns in the tubular hinge member of the other section, and means for holding the two sections from endwise separation, said means comprising a member on the handle turned section that snaps over the outer end of the other tubular section as the two sections are moved into operative connection.

2. In a griddle, a pair of similar griddle sections, each of which includes a tubular hinge member, the hinge members of the two sections alining when the parts are assembled, each of the said sections including a rim flange, a handle which includes a rod member adapted to extend through the two tubular hinge members and which is held to turn freely within the outer end of one of the hinge members, means cooperating with the other of the said tubular members and the handle for locking the handle and

the said other tubular member to turn together as the rod turns in the first mentioned tubular hinge member, and means for holding the two tubular hinge members from endwise separation, the said means including an extension of the rim flange of that section which turns with the handle for snapping over the outer end of the outermost tubular hinge member.

3. In a griddle, a pair of like sections each having a rim flange and a tubular hinge member, the said hinge members being in longitudinal alinement when the sections are operatively assembled, a handle that includes a rod slidable through the tubular hinge members, means cooperating with the handle and one of the said sections for locking the said one of the sections and the handle to turn together, and further means on the section that moves with the handle for interlocking with the outer end of the tubular hinge member of the other section to hold the said other section from endwise movement on the rod, the said further means including a resilient portion on the flange of the section that turns with the rod and which is adapted to snap over the end of the tubular hinge section when the sections are closed upon each other.

THOMAS J. NASH.

Witnesses:

LEO J. SCHMITTEL,
W. E. RODGERS.

Copies of this patent may be obtained for five cents each, by addressing the "Commissioner of Patents, Washington, D. C."