

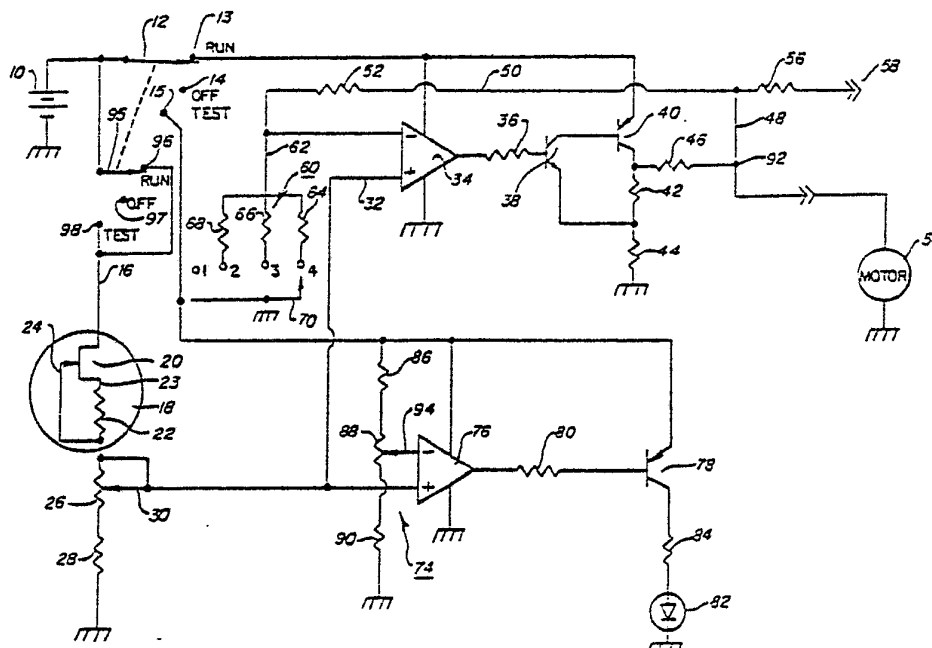

INTERNATIONAL APPLICATION PUBLISHED UNDER THE PATENT COOPERATION TREATY (PCT)

<p>(51) International Patent Classification³ : H02J 7/00; H02P 5/00, 7/06 H02P 7/14; G05F 1/10, 1/46 G05F 1/50</p>	<p>A1</p>	<p>(11) International Publication Number: WO 82/ 03298 (43) International Publication Date: 30 September 1982 (30.09.82)</p>
<p>(21) International Application Number: PCT/US82/00193 (22) International Filing Date: 16 February 1982 (16.02.82) (31) Priority Application Number: 243,539 (32) Priority Date: 13 March 1981 (13.03.81) (33) Priority Country: US (71) Applicant: BAXTER TRAVENOL LABORATORIES, INC. [US/US]; One Baxter Parkway, Deerfield, IL 60015 (US). (72) Inventor: FELDMAN, Gary : 331 Vista Drive, Wilmette, IL 60091 (US). (74) Agents: PRICE, Bradford, R., L. et al.; Baxter Travenol Laboratories, Inc., One Baxter Parkway, Deerfield, IL 60015 (US).</p>	<p>(81) Designated States: DE (European patent), FR (European patent), GB (European patent). Published <i>With international search report.</i></p>	

(54) Title: VOLTAGE REGULATOR IN MOTOR CONTROL



(57) Abstract

Battery-operated motor control circuit. An adjustable voltage reference (18, 26, 28) is coupled to the battery (10), with the output of the adjustable voltage reference being coupled to the positive input of an operational amplifier (34). The negative input of the operational amplifier (34) is coupled to ratio control means (60) for setting the gain of the operational amplifier (34) and thus setting the motor (54) to a selected speed. A transistor-pair amplifier (38, 40) is coupled to the output of the operational amplifier (34), with a negative feedback line (50) being coupled from the output of the transistor amplifier to the negative input of the operational amplifier. The motor is also coupled to the output of the transistor amplifier.

FOR THE PURPOSES OF INFORMATION ONLY

Codes used to identify States party to the PCT on the front pages of pamphlets publishing international applications under the PCT.

AT	Austria	KP	Democratic People's Republic of Korea
AU	Australia	LI	Liechtenstein
BE	Belgium	LK	Sri Lanka
BR	Brazil	LU	Luxembourg
CF	Central African Republic	MC	Monaco
CG	Congo	MG	Madagascar
CH	Switzerland	MW	Malawi
CM	Cameroon	NL	Netherlands
DE	Germany, Federal Republic of	NO	Norway
DK	Denmark	RO	Romania
FI	Finland	SE	Sweden
FR	France	SN	Senegal
GA	Gabon	SU	Soviet Union
GB	United Kingdom	TD	Chad
HU	Hungary	TG	Togo
JP	Japan	US	United States of America

VOLTAGE REGULATOR IN MOTOR CONTROL

FIELD OF THE INVENTION

The present invention concerns a novel voltage regulator circuit, and more particularly, a voltage regulator circuit that has significant utility to the control of a
5 battery-operated motor.

BACKGROUND ART

Ambulatory low volume infusion pumps are known for use in connection with infusion of various fluids to a patient. In one prior art ambulatory battery-operated infusion device, a physician calibrates for a flow rate by adjusting a trimming potentiometer and viewing the adjustment on a meter. Various inaccuracies have been found using this prior art system.

In order to have a successful ambulatory infusion pump, it is essential that the pump have predictable variable speeds in order to give predictable flow rates. The selected flow rates must remain constant over various states of charge of the battery. Further, a reasonable torque control is required in order to be able to control the flow rates over the different speed settings.

It is, therefore, an object of the invention to provide a voltage regulator circuit that is operative with a battery-operated motor to provide predictable accurate flow rates (motor speeds) notwithstanding variable loads and notwithstanding the variable input voltages resulting from variations in the condition of the battery voltage.

It is another object of the present invention to provide a voltage regulator circuit which is constructed to have a terminal which can be connected to a computer or the like to measure the functioning of the circuitry, including the actual flow rates at all the speeds, the battery voltage and the current used.

A further object of the present invention is to provide a voltage regulator circuit that can be enclosed in a small module and be completely testable with a single output.

Other objects and advantages of the present invention will become apparent as the description proceeds.



DISCLOSURE OF THE INVENTION

In accordance with the present invention, a voltage regulator circuit is provided which comprises a DC voltage input and means coupled to the input for providing a voltage reference. First amplifier means having its positive input coupled to the voltage reference means is provided and the negative input of the first amplifier means is coupled to ratio control means for setting the gain of the first amplifier means. Negative feedback means are coupled from an output of the first amplifier means to the negative input of the first amplifier means.

In the illustrative embodiment, the voltage reference means comprises a current regulating circuit in series with a potentiometer. The arm of the potentiometer is coupled to the positive input of the first amplifier means, thereby providing an adjustable voltage reference. The first amplifier means includes a pair of transistors connected to provide a double inversion and the ratio control means comprises a plurality of resistors and means for coupling to ground a selected resistor of the plurality of resistors.

In the illustrative embodiment, the feedback means includes a series resistor. The ratio control means is operative to provide a voltage ratio factor at the output of the first amplifier means that is equal to about $1 + R_{fb}/R_g$ where R_{fb} is the resistance of the series resistor and R_g is the resistance of the selected resistor of the plurality of resistors.

In the illustrative embodiment, the positive input of a second amplifier means is coupled to the voltage reference means. A voltage divider is coupled to the positive input of the second amplifier means for simulating the load at the output of the first amplifying means. Indicating means, such as a light emitting diode, are coupled to the output of the second amplifier means for indicating the battery condition.



In the illustrative embodiment, the system takes the form of a battery-operated motor control circuit, operating to drive an ambulatory infusion pump for infusing fluids into a patient.

5 A more detailed explanation of the invention is provided in the accompanying drawings.

BRIEF DESCRIPTION OF THE DRAWINGS

10 The Figure is a schematic circuit diagram of a voltage regulator circuit constructed in accordance with the principles of the present invention.

DETAILED DESCRIPTION OF THE
ILLUSTRATIVE EMBODIMENT

Referring to the drawing, a battery 10 having its negative terminal connected to ground is connected to a double pole, triple throw switch 12, 95 having "run" terminals 13, 96, "off" terminals 14, 97 and "test" terminals 15, 98. Run terminal 96 and test terminal 98 are connected to a drain terminal 16 of a current regulator circuit 18. Current regulator circuit 18 comprises an FET 20 and a resistor 22. The source terminal 23 is connected to the gate 24 through resistor 22 and gate 24 is connected to a potentiometer 26 which is connected to ground through resistor 28.

The arm of potentiometer 26 is connected via line 32 to the positive terminal of an operational amplifier 34. The output of operational amplifier 34 is connected through resistor 36 to the base of an NPN transistor 38, the collector of which is connected to the base of a PNP transistor 40 and the emitter of which is connected to the collector of transistor 40 through resistor 42. The emitter of transistor 38 is connected to ground through resistor 44.

Transistors 38 and 40 comprise a power booster circuit for operational amplifier 34. The operational amplifier 34 cannot alone drive a motor as required, because it does not have suitable power. Further, the saturation output voltage of operational amplifier 34 would be a problem even if it could drive the motor. By connecting transistors 38 and 40 so that the collector of transistor 38 drives the base of transistor 40, a double inversion is obtained, thereby resulting in the same phase as the output of operational amplifier 34. This enables a feedback circuit to the negative terminal of operational amplifier 34 from the collector of transistor 40, through current limiting resistor 46, line 48, line 50 and resistor 52. The resulting circuit has an extremely low voltage drop between the output and power source. For example, a power

source of 2.2 volts can be used to regulate a final output voltage to the motor requirement of 2.1 volts or to within about 0.1 volt of the battery voltage.

5 Output line 48 is coupled to motor 54 and also through resistor 56 to a terminal 58 which may be connected to measuring means, such as a meter or a computer.

Ratio control means 60 is coupled via line 62 to the negative input terminal of operational amplifier 34. Ratio control means 60 comprises parallel connected resistors 10 64, 66 and 68, with a grounded single pole switch arm 70 that is adapted for connecting to either resistor 64 by contacting terminal 4, resistor 66 by contacting terminal 3, resistor 68 by contacting terminal 2 or no resistor by contacting terminal 1. Resistor 64 has the lowest resistance, resistor 66 has the next lowest resistance, resistor 15 68 has a higher resistance and, of course, an infinite resistance is provided when the switch arm 70 contacts terminal 1.

Resistors 64, 66 and 68 can be selected to provide 20 a predetermined speed ratio for the motor, once the initial speed of the motor is calibrated. In order to calibrate the initial speed of the motor, switch arm 70 is connected to terminal 4 of ratio control means 60. This will be the highest speed of the motor at which there is most ripple 25 thereby providing the greatest spikes for the operator to observe. Assuming that motor 54 is a five-pole motor, there will be ten spikes per revolution of the motor. By coupling measuring means to terminal 58 and knowing that there are ten spikes per revolution of the motor, it is 30 simple to determine the precise speed over the motor for a particular time period. This is most easily accomplished when the switch arm 70 is connected to terminal 4 because of the large ripple that is achieved. While the operator notes the speed at output 58, the precise speed desired 35 is calibrated by moving arm 30 of potentiometer 26. Once this maximum speed is calibrated, the other selected speeds are obtained by merely moving switch arm 70 of gain control

means 60 to terminal 3, or 2 or 1, depending upon the speed desired.

With switch arm 70 at terminal 1, motor 54 has the same voltage as the voltage on line 32. With switch arm
5 70 at terminal 2, motor 54 has the voltage on line 32 times $(1 + R_{fb}/R_g)$ where R_{fb} is the resistance of resistor 52 and R_g is the resistance of 68. Likewise, when switch arm 70 is connected to terminal 3, motor 54 will have the voltage on line 32 times $(1 + R_{fb}/R_g)$ where R_{fb} is the resistance
10 of resistor 52 and R_g is the resistance of resistor 64.

A test circuit 74 is provided as follows. Arm 30 of potentiometer 26 is connected to the positive input terminal of a second operational amplifier 76. The output of operational amplifier 76 is connected to the base of a PNP transistor 78 through resistor 80. The collector of PNP transistor 78 is connected to an indicating means 82, in the form of an LED, through resistor 84. The negative input of operational amplifier 76 is connected to a voltage divider circuit comprising a first resistor 86 connected to
15 the positive test terminal 15, a potentiometer 88 and a resistor 90 connected to ground.

Resistors 86 and 90 and potentiometer 88, which form a voltage divider circuit, are of such value to load the battery 10 slightly in excess of the motor load. Thus the
25 energization of an LED in a test made will serve to indicate that the power supply has sufficient reserve to operate the system.

By utilizing the aforementioned circuit, the selected motor speeds will remain constant over various states of
30 charge of battery 10. If the load on motor 54 increases, the voltage at point 92 tends to drop. This is sensed at the negative input of operational amplifier 34 which drives the output at point 92 back to its initial level increasing motor torque. At stall the circuit is protected and
35 the motor torque is limited by resistor 46. After the voltage on line 32 has been set, arm 94 of potentiometer 88 can be moved to adjust operational amplifier 76 so that

LED 82 will be a low voltage indicator.

The system is particularly useful in an ambulatory low volume infusion pump. Typically, four desired flow rates may be appropriate. Thus resistors 64, 66 and 68
5 are elected so as to provide the proper flow speed ratios.

When the system is not in use, switch 12 will be in its "off" position. Testing may be accomplished by placing the switch in the "test" position and operation of the motor 54 is accomplished with the switch in the "run" position.
10

It is seen that a voltage regulator circuit has been provided that is operative with a battery-operated motor to provide predictable accurate motor speeds, notwithstanding variable loads and notwithstanding the variable input
15 voltages resulting from variations in the condition of the battery voltage.

Although an illustrative embodiment of the invention has been shown and described, it is to be understood that various modifications and substitutions may be made
20 without departing from the novel spirit and scope of the present invention.

THAT WHICH IS CLAIMED IS:

1. A voltage regulator circuit which comprises:
a DC voltage input;
means coupled to said input for providing a voltage
5 reference;
first amplifier means having a positive input, a negative input and an output, said first amplifier means having one of its inputs coupled to said voltage reference means;
10 ratio control means coupled to the other input of said amplifier means for setting the gain of said first amplifier means;
feedback means coupled from an output of said first amplifier means to said other input of said first amplifier means;
15 a second amplifier means having a positive input, a negative input and an output;
means coupling said voltage reference to one of the inputs of said second amplifier means;
20 a voltage divider coupled to the other input of said second amplifier means for simulating the load at the output of said first amplifier means; and
indicating means coupled to the output of said second amplifier means.
- 25 2. A voltage regulator circuit as described in Claim 1, said voltage reference means comprising a current regulating circuit in series with a potentiometer, with the arm of the potentiometer coupled to said one input, thereby providing an adjustable voltage reference.
- 30 3. A voltage regulator circuit as described in Claim 1, said first amplifying means including a pair of transistors connected to provide a double inversion,
4. A voltage regulator circuit as described in Claim

3, said first amplifying means including an NPN transistor the base of which is coupled to the output of said first amplifier means, a PNP transistor the base of which is coupled to the collector of said NPN transistor, a resistor coupling the emitter of said NPN transistor to the collector of the PNP transistor; said feedback means coupling the collector of said PNP transistor to the negative input of the first amplifier means.

5. A voltage regulator circuit as described in Claim 1, said ratio control means comprising a plurality of resistors and means for coupling to ground a selected resistor of said plurality.

6. A voltage regulator circuit as described in Claim 5, said feedback means including a series resistor and said ratio means being operative to provide a voltage ratio factor at the input of the first amplifier means that is equal to about $1 + R_{fb}/R_g$ where R_{fb} is the resistance of said series resistor and R_g is the resistance of the selected resistor of said plurality.

7. A voltage regulator circuit as described in Claim 1, said second amplifying means including an amplifier coupled to the output of an operational amplifier; and said indicating means being coupled to the output of said amplifier.

8. A voltage regulator circuit as described in Claim 7, said amplifier comprising a transistor and said indicating means comprising a light emitting diode.

9. A voltage regulator circuit as described in Claim 1, including means for adjusting said voltage reference means;

a motor coupled to an output of said first amplifier means;



a measurement terminal coupled to said first amplifier means output; and

said adjusting means being operative to calibrate the motor speed.

5 10. A voltage regulator circuit as described in Claim 9, said ratio control means being operable to selectively control the motor speed, said ratio control means comprising a plurality of resistors and means for coupling to ground a selected resistor of said plurality.

10 11. A voltage regulator circuit which comprises:
a DC voltage input;
means coupled to said input for providing an adjustable voltage reference, said adjustable voltage reference means comprising a current regulating circuit in series
15 with a potentiometer;
first amplifier means having a positive input, a negative input and an output;
the arm of the potentiometer being coupled to said positive input, thereby providing an adjustable voltage
20 reference;

ratio control means coupled to the negative input of said first amplifier means for setting the gain of said first amplifier means, said ratio control means comprising a plurality of resistors and means for coupling to ground
25 a selected resistor of said plurality;

feedback means coupled from an output of said first amplifier means to said other input of said first amplifier means;

30 said feedback means including a series resistor and said ratio means being operative to provide a voltage ratio factor at the input of the amplifier means that is equal to about $1 + R_{fb}/R_g$ where R_{fb} is the resistance of said series resistor and R_g is the resistance of the selected resistor of said plurality;

35 a motor coupled to an output of said first amplifier

means;

a measurement terminal coupled to said first amplifier means output; and

5 said potentiometer arm being operative to calibrate the motor speed.

12. A voltage regulator circuit as described in Claim 11, including second amplifier means having a positive input, a negative input and an output;

10 means coupling said voltage reference to the input of said second amplifier means;

the voltage divider coupled to the positive input of said second amplifier means for simulating the load at the output of said first amplifier means; and

15 indicating means coupled to the output of said second operational amplifier.

13. A voltage regulator circuit as described in Claim 12, said second amplifier means including an amplifier coupled to the output of an operational amplifier; and said indicating means coupled to the output of said
20 amplifier.

14. A voltage regulator circuit as described in Claim 13, said first amplifying means including a pair of transistors connected to provide a double inversion, said pair comprising an NPN transistor the base of which is coupled to the output of said first amplifier means, a PNP
25 transistor the base of which is coupled to the collector of said NPN transistor, a resistor coupling the emitter of said NPN transistor to the collector of the PNP transistor; said negative feedback means coupling the collector of said PNP transistor to the negative input of the
30 first amplifier means.

15. A battery-operated motor control circuit, which comprises:

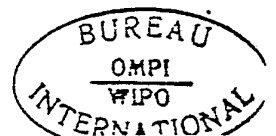

a battery;

means coupled to said battery for providing an adjustable voltage input;

5 first amplifier means having a positive input; a negative and an output, the positive input being coupled to said adjustable voltage input;

10 ratio control means coupled to the negative input of said first amplifier means for setting the gain of said first amplifier means and thus setting the speed of the motor, said ratio control means being operable to selectively control the motor speed in discrete increments;

negative feedback means coupled from an output of said first amplifying means to the negative input of said first amplifier means; and

15 means coupling an output of said first amplifying means to the motor.

20 16. A device as described in Claim 15, said ratio control means comprising a plurality of resistors and means for coupling to ground a selected resistor of said plurality.

25 17. A device as described in Claim 16, said feedback means including a series resistor and said ratio control means being operative to provide a voltage ratio factor at the input of the first amplifier means that is equal to about $1 + R_{fb}/R_g$ where R_{fb} is the resistance of said series resistor and R_g is the resistance of the selected resistor of said plurality.

30 18. A device as described in Claim 15, including second amplifier means having a positive input, a negative input and an output;

means coupling said adjustable voltage input to the positive input of said second amplifier means;

a voltage divider coupled to the positive input of said second amplifier means for simulating the load at

the output of said first amplifying means; and
indicating means coupled to the output of said second
amplifier means.

19. A device as described in Claim 15, said first
5 amplifier means including an NPN transistor the base of
which is coupled to the output of said first amplifier
means, a PNP transistor the base of which is coupled to
the collector of said NPN transistor, a resistor coupling
the emitter of said NPN transistor to the collector of
10 the PNP transistor; said negative feedback means coupling
the collector of said PNP transistor to the negative input
of the first amplifier means.

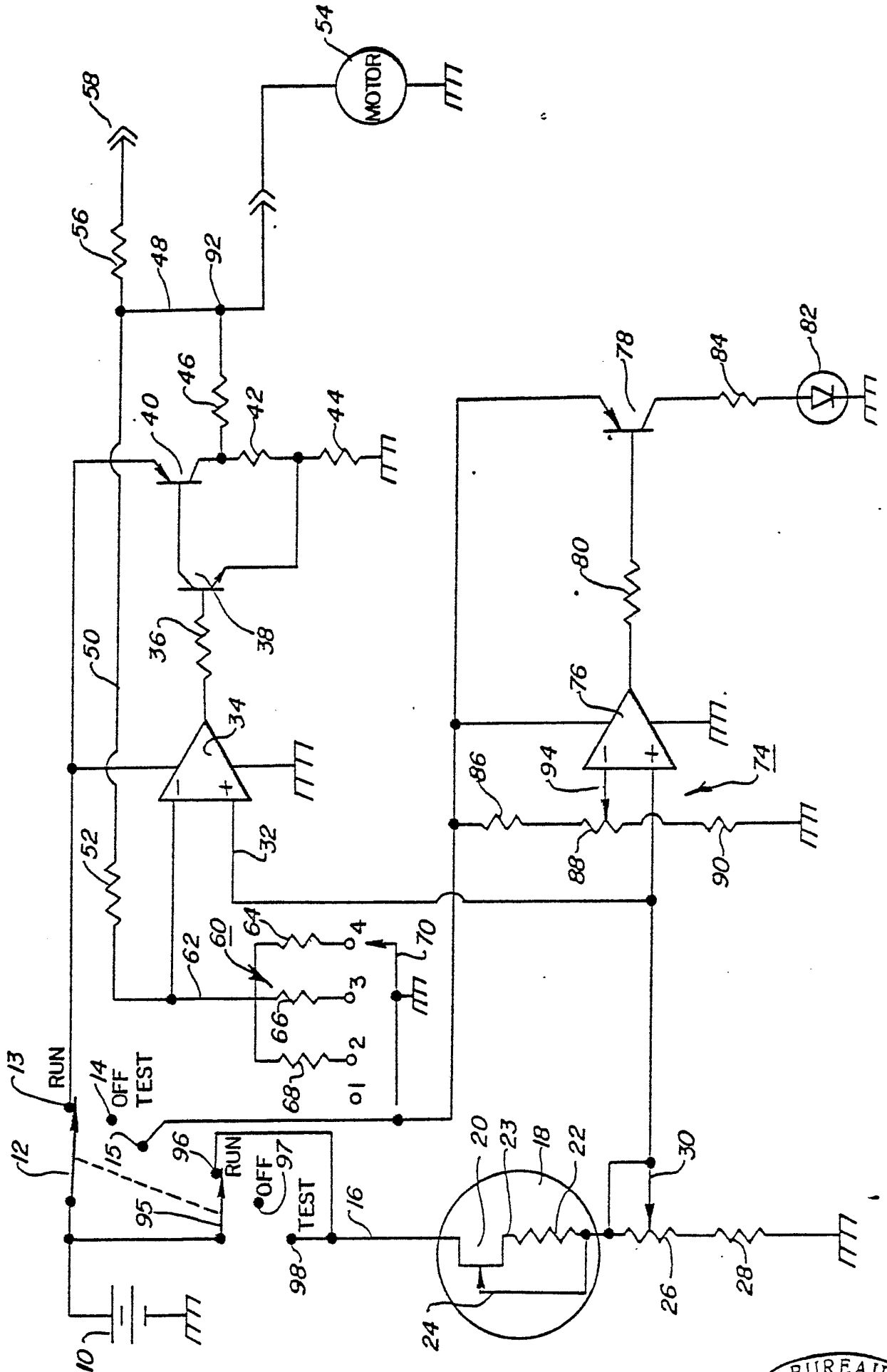

INTERNATIONAL SEARCH REPORT

International Application No PCT/US82/00193

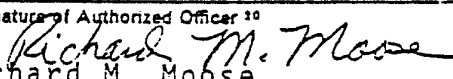
I. CLASSIFICATION OF SUBJECT MATTER (If several classification symbols apply, indicate all) ³				
According to International Patent Classification (IPC) or to both National Classification and IPC				
Int. Cl. ³ H02J 7/00; H01p 5/00; 7/06; 7/14; G05F, 1/10, 1/46, 1/50 U.S. CL. 318/139, 305, 315, 317, 332, 342, 323/273, 280, 281				
II. FIELDS SEARCHED				
Minimum Documentation Searched ⁴				
Classification System	Classification Symbols			
Documentation Searched other than Minimum Documentation to the extent that such Documents are included in the Fields Searched ⁵				
III. DOCUMENTS CONSIDERED TO BE RELEVANT ¹⁴				
Category ⁶	Citation of Document, ¹⁶ with indication, where appropriate, of the relevant passages ¹⁷	Relevant to Claim No. ¹⁸		
X,P	US, A, 4,274,036, Published 16 Jun, 1981 Fukasaku et al.	11,15		
X,P	US, A, 4,291,259, Published 22 Sept. 1981 Marumoto et al.	11 15,-17		
X	US, A, 4,211,961, Published 08 July 1980 Marumoto et al.	11, 15-17		
X	US, A 4,075,970, Published 28 February 1978, See Fig. 2, Blake et al.	5, 10, 16		
X	US, A, 3,855,511, published 17 Dec, 1974 Smith	6,9,11		
X	US, A, 3,947,753, published 30 March 1976 Gushima et al.	7,8,12,18		
X	US, A, 3,401,335, Published 10 Sept. 1968 Perkinson	7,12,18		
A	US, A, 4,151,456, Published 24 April 1979 Black	1,2,11,15		
<p>⁹ Special categories of cited documents: ¹⁵</p> <table style="width: 100%; border: none;"> <tr> <td style="width: 50%; border: none;"> <p>"A" document defining the general state of the art</p> <p>"E" earlier document but published on or after the international filing date</p> <p>"L" document cited for special reason other than those referred to in the other categories</p> <p>"O" document referring to an oral disclosure, use, exhibition or other means</p> </td> <td style="width: 50%; border: none;"> <p>"P" document published prior to the international filing date but on or after the priority date claimed</p> <p>"T" later document published on or after the international filing date or priority date and not in conflict with the application, but cited to understand the principle or theory underlying the invention</p> <p>"X" document of particular relevance</p> </td> </tr> </table>			<p>"A" document defining the general state of the art</p> <p>"E" earlier document but published on or after the international filing date</p> <p>"L" document cited for special reason other than those referred to in the other categories</p> <p>"O" document referring to an oral disclosure, use, exhibition or other means</p>	<p>"P" document published prior to the international filing date but on or after the priority date claimed</p> <p>"T" later document published on or after the international filing date or priority date and not in conflict with the application, but cited to understand the principle or theory underlying the invention</p> <p>"X" document of particular relevance</p>
<p>"A" document defining the general state of the art</p> <p>"E" earlier document but published on or after the international filing date</p> <p>"L" document cited for special reason other than those referred to in the other categories</p> <p>"O" document referring to an oral disclosure, use, exhibition or other means</p>	<p>"P" document published prior to the international filing date but on or after the priority date claimed</p> <p>"T" later document published on or after the international filing date or priority date and not in conflict with the application, but cited to understand the principle or theory underlying the invention</p> <p>"X" document of particular relevance</p>			
IV. CERTIFICATION				
Date of the Actual Completion of the International Search ²	Date of Mailing of this International Search Report ³			
22 April 1982	27 APR 1982			
International Searching Authority ¹	Signature of Authorized Officer ¹⁰			
ISA/US	 Richard M. Moose			

FURTHER INFORMATION CONTINUED FROM THE SECOND SHEET

A	US,A. 4,251,743, Published 17 Feb. 1981 Hareyama	1,2,11,15
A	US,A, 4,007,415, Published 08 Feb. 1977 Toyoda	1,2,11,15
A	US, A 4,215,383 Published 29 July 1980, Boyd et al.	1-19
A	US, A. 3, 815,001 published 04 June 1974, Jamieson	1-19
A,P	US, A, 4,264,785, published 28 April 1981 Jacobson	1-19

V. OBSERVATIONS WHERE CERTAIN CLAIMS WERE FOUND UNSEARCHABLE ¹⁰

This international search report has not been established in respect of certain claims under Article 17(2) (a) for the following reasons:

1. Claim numbers _____, because they relate to subject matter ¹² not required to be searched by this Authority, namely:

2. Claim numbers _____, because they relate to parts of the international application that do not comply with the prescribed requirements to such an extent that no meaningful international search can be carried out ¹³, specifically:

VI. OBSERVATIONS WHERE UNITY OF INVENTION IS LACKING ¹¹

This International Searching Authority found multiple inventions in this international application as follows:

1. As all required additional search fees were timely paid by the applicant, this international search report covers all searchable claims of the international application.

2. As only some of the required additional search fees were timely paid by the applicant, this international search report covers only those claims of the international application for which fees were paid, specifically claims:

3. No required additional search fees were timely paid by the applicant. Consequently, this international search report is restricted to the invention first mentioned in the claims; it is covered by claim numbers:

Remark on Protest

- The additional search fees were accompanied by applicant's protest.
- No protest accompanied the payment of additional search fees.

III. DOCUMENTS CONSIDERED TO BE RELEVANT (CONTINUED FROM THE SECOND SHEET)

Category *	Citation of Document, ¹⁶ with indication, where appropriate, of the relevant passages ¹⁷	Relevant to Claim No ¹⁸
------------	--	------------------------------------

A

US, A, 3,566,252, Published 23 Feb. 1971
Nercessian

1-19