

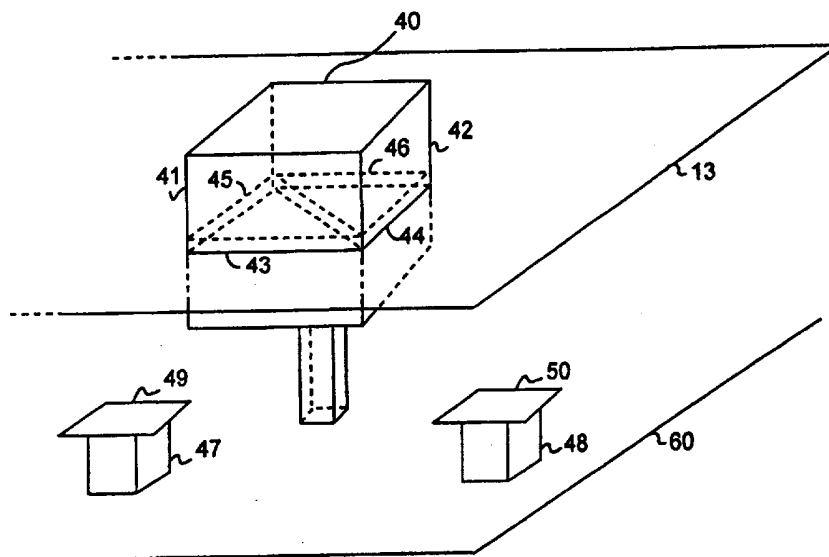

INTERNATIONAL APPLICATION PUBLISHED UNDER THE PATENT COOPERATION TREATY (PCT)

(51) International Patent Classification ⁶ : H01H 13/70	A1	(11) International Publication Number: WO 98/01876 (43) International Publication Date: 15 January 1998 (15.01.98)
<p>(21) International Application Number: PCT/IB97/00765</p> <p>(22) International Filing Date: 23 June 1997 (23.06.97)</p> <p>(30) Priority Data: 96/08285 3 July 1996 (03.07.96) FR</p> <p>(71) Applicant (for all designated States except US): PHILIPS ELECTRONICS N.V. [NL/NL]; Groenewoudseweg 1, NL-5621 BA Eindhoven (NL).</p> <p>(72) Inventor; and (75) Inventor/Applicant (for US only): ANDRE, Jean-Marie [FR/FR]; Prof. Holstlaan 6, NL-5656 AA Eindhoven (NL).</p> <p>(74) Agent: CHAFFRAIX, Jean; Internationaal Octrooibureau B.V., P.O. Box 220, NL-5600 AE Eindhoven (NL).</p>	<p>(81) Designated States: CN, JP, KR, US, European patent (AT, BE, CH, DE, DK, ES, FI, FR, GB, GR, IE, IT, LU, MC, NL, PT, SE).</p> <p>Published With international search report.</p>	

(54) Title: KEYBOARD WITH MULTIFUNCTION KEYS AND APPARATUS INCLUDING SUCH A KEYBOARD



(57) Abstract

The invention permits modifying the label indicated on a key of a keyboard by influencing the lighting of the keyboard. Therefore, the invention utilizes keys that allow light to pass through and whose surface is subdivided into two parts to which two different labels are associated. And the invention provides means for selectively lighting either part of the key. Therefore, two polarizing filters whose planes of polarization are perpendicular are associated to said key opposite said parts, and two light sources each emitting polarized light in one of these planes respectively, are selectively used to light said key. Thus, depending on the light source that is activated, the label which appears on the key is modified. Applications: any type of apparatus which includes a keyboard.

FOR THE PURPOSES OF INFORMATION ONLY

Codes used to identify States party to the PCT on the front pages of pamphlets publishing international applications under the PCT.

AL	Albania	ES	Spain	LS	Lesotho	SI	Slovenia
AM	Armenia	FI	Finland	LT	Lithuania	SK	Slovakia
AT	Austria	FR	France	LU	Luxembourg	SN	Senegal
AU	Australia	GA	Gabon	LV	Latvia	SZ	Swaziland
AZ	Azerbaijan	GB	United Kingdom	MC	Monaco	TD	Chad
BA	Bosnia and Herzegovina	GE	Georgia	MD	Republic of Moldova	TG	Togo
BB	Barbados	GH	Ghana	MG	Madagascar	TJ	Tajikistan
BE	Belgium	GN	Guinea	MK	The former Yugoslav Republic of Macedonia	TM	Turkmenistan
BF	Burkina Faso	GR	Greece	ML	Mali	TR	Turkey
BG	Bulgaria	HU	Hungary	MN	Mongolia	TT	Trinidad and Tobago
BJ	Benin	IE	Ireland	MR	Mauritania	UA	Ukraine
BR	Brazil	IL	Israel	MW	Malawi	UG	Uganda
BY	Belarus	IS	Iceland	MX	Mexico	US	United States of America
CA	Canada	IT	Italy	NE	Niger	UZ	Uzbekistan
CF	Central African Republic	JP	Japan	NL	Netherlands	VN	Viet Nam
CG	Congo	KE	Kenya	NO	Norway	YU	Yugoslavia
CH	Switzerland	KG	Kyrgyzstan	NZ	New Zealand	ZW	Zimbabwe
CI	Côte d'Ivoire	KP	Democratic People's Republic of Korea	PL	Poland		
CM	Cameroon	KR	Republic of Korea	PT	Portugal		
CN	China	KZ	Kazakstan	RO	Romania		
CU	Cuba	LC	Saint Lucia	RU	Russian Federation		
CZ	Czech Republic	LI	Liechtenstein	SD	Sudan		
DE	Germany	LK	Sri Lanka	SE	Sweden		
DK	Denmark	LR	Liberia	SG	Singapore		
EE	Estonia						

Keyboard with multifunction keys and apparatus including such a keyboard

The invention relates to an apparatus including a keyboard with at least one key that allows light to pass through which indicates a label that admits of being modified.

The invention also relates to a keyboard having at least one key that
5 allows light to pass through which indicates a label that admits of being modified.

The invention finally relates to a method of modifying the label indicated on a key of a keyboard, which key allows light to pass through.

Background of the invention

Such a keyboard is notably described in the journal "IBM Technical
10 Disclosure Bulletin" vol. 27, No. 11, pp. 6604 and 6605, April 1985. The keyboard described in that document comprises keys formed on the basis of a liquid crystal display unit which is controlled via a specific circuit for displaying the desired character.

Such a keyboard makes it possible to modify the label of each key as desired when one wishes to change font or function. However, the device used, which is
15 based on liquid crystals, is costly and relatively complex.

Summary of the invention

It is an object of the invention to propose a simpler, inexpensive keyboard particularly well adapted for electronic apparatus intended for the consumer market, notably for portable apparatus which have small-size keyboards and on which various functions are
20 currently assigned to the same key.

Therefore, an apparatus according to the invention and as defined in the opening paragraph is characterized in that the surface of said key is divided into two parts to which two different labels are associated, and in that it comprises selective lighting means for lighting either part.

25 In a particularly inexpensive embodiment which is also easy to use, said selective lighting means comprise:

- two polarizing filters whose polarization planes are normal and which are associated to said key opposite said parts,
- and two light sources each light source respectively emitting a polarized light in

one of said planes, and being selectively lit for lighting said key.

The invention is advantageously used in a telephone terminal, notably a portable telephone terminal. To reduce the size of this type of apparatus, one is in effect led to limit the number of keys of the keyboard and thus regroup various functions under the same key, which complicates the handling of the apparatus. The invention permits of
5 avoiding any combined handling of keys for selecting the sought function and thus considerably facilitates the handling of this type of apparatus for the consumers.

For another embodiment, said keyboard includes a selection key for selecting a mode of operation, said key permitting of controlling the selective lighting of said
10 keyboard.

Thus, all the labels carried by the multifunction keys are modified when a mode of operation is changed.

Brief description of the drawings

These and other aspects of the invention will be apparent from and
15 elucidated with reference to the embodiments described hereinafter.

In the drawings:

Fig. 1 represents an example of a telephone apparatus according to the
20 invention,

Figs. 2 and 3 represent two different states of an example of a keyboard according to the invention, and

Fig. 4 represents an embodiment of a keyboard according to the invention.

25 Description of preferred embodiments

In Fig. 1 is represented a mobile telephone 11 which comprises a screen 12, a keyboard 13 with keys, a loudspeaker/receiver 15, a microphone 16, and an antenna 17.

In the embodiment described here by way of example, the keyboard
30 comprises fifteen keys and the terminal has two modes of operation. The key 20 makes it possible to select a mode of operation of the terminal and to transform the keyboard conforming to the selected mode of operation.

The first mode of operation of the terminal is the telephone mode; it provides the conventional telephone functions. The keyboard of the terminal in this mode of

operation is represented in Fig. 2. According to Fig. 2, the selection key 20 is labeled "TEL" to indicate that the terminal is in the telephone mode. Two keys 21 and 22 carry the respective labels "LINE" and "END" to indicate the functions of seizing and returning the line. The keys 23 to 34 carry the conventional symbols of a telephone keyboard, that is to say, the digits 0 to 9 and the symbols # and *.

The second mode of operation of the terminal is the menu mode; it permits of configuring the various parameters of the terminal (choice of the type and volume of the ringing sound, for example), of consulting various indicators (state of charge of the batteries, for example), reading messages in the message box ... The keyboard of the terminal in this mode of operation is represented in Fig. 3. According to Fig. 3, the selection key 20 is then labeled "MENU" to indicate that the terminal is in the menu mode, the keys 21 and 22 carry the respective symbols "+" and "-" to indicate the moving function for moving upwards or downwards in a list, or the function of augmenting or diminishing a value. The keys 23 to 34 carry symbols indicating the various functions available on the telephone. By way of example, the key 23 is labeled "VOL" to indicate the function of volume regulation. The key 24 is labeled "RING" to indicate the function of a ringing option. The key 25 is labeled "BATTERY" to indicate the function of consulting the charging state of the battery ...

In Fig. 4 is represented in detail a key of the keyboard, whose label admits of being modified, and the selective lighting means of the keyboard.

In accordance with the invention, this key 40 is realized to allow the light to pass and it is divided into two parts 41 and 42 marked off by the diagonal of the square surface of the key. On either one of these parts is stuck a film that carries one of the two labels associated to the key. For example, for key 20 of the telephone of Fig. 1, one of the films is labeled "MENU" and the other film carries the "TEL" label. These films are referenced 43 and 44 in Fig. 4. On top of or underneath these films one has also stuck to polarizing filters 45 and 46 whose polarization planes are normal. The filter 45 is provided for filtering the polarized light in a first direction and emitting the polarized light in a second direction perpendicular to the first direction. In contrast, the filter 46 is provided for filtering the polarized light in said second direction and emitting the polarized light in said first direction.

In accordance with the invention, two polarized light sources are used in perpendicular planes to light the keyboard. In practice, these light sources are formed on the basis of light-emitting diodes on which polarizing films are stuck. In the Figure are

represented two light-emitting diodes 47 and 48. On diode 47 is stuck a film 49 to polarize the light in said second direction and on diode 48 is stuck a film 50 to polarize the light in said first direction. Thus, the light emitted by the diode 47 is filtered by the filter 46 and transmitted by the filter 45. In contrast, the light emitted by the diode 48 is filtered by the filter 45 and transmitted by the filter 46.

If one recaptures the example of the key 20 of the telephone of Fig. 1, when the lighting of the diode 47 is controlled by selecting the telephone mode, the "TEL" label shows up on the key. And when the diode 48 is controlled by selecting the menu mode, the "MENU" label shows up on the key.

These diodes are soldered directly onto the printed circuit 60 of the telephone which is located underneath the keyboard. They are spread over the surface of the circuit so as to be able to light the whole keyboard.

A keyboard according to the invention includes one or various keys of the type which has just been described. When the fifteen keys of the telephone represented in Fig. 1 are of this type, four light-emitting diodes will suffice to light the whole keyboard (two diodes for permitting the polarized light in said first direction, and two other diodes for emitting a polarized light in said second direction).

It will be obvious that modifications may be made in the embodiment which has just been described, notably by substituting equivalent technical means, without one leaving the scope of the present invention. More particularly, the invention in essence consists of varying the lighting of the keyboard before one or the other of the two labels associated to a key is displayed. The embodiment of this concept is admitting of variation.

Moreover, although the invention has been described for a telephone, it is applicable to any other type of apparatus including a keyboard. For example, it is applicable to calculators, electronic diaries, measuring apparatus (oscilloscopes, multimeters ...).

The keyboard according to the invention may comprise any number of keys, all of them or part of them admitting of indicating various labels, as has been described above. It is also possible that certain keys are only lit from the back, and the form of these keys may certainly be any form.

Claims

1. An apparatus including a keyboard with at least one key that allows light to pass through which indicates a label that admits of being modified, characterized in that the surface of said key is divided into two parts to which two different labels are associated, and in that it comprises selective lighting means for lighting either part.
- 5 2. An apparatus as claimed in claim 1, characterized in that said selective lighting means comprise:
 - two polarizing filters whose polarization planes are normal and which are associated to said key opposite said parts,
 - and two light sources, each light source respectively emitting a polarized light
- 10 in one of said planes, and being selectively lit for lighting said key.
3. An apparatus as claimed in one of the claims 1 or 2, characterized in that said keyboard includes a selection key for selecting a mode of operation, said key permitting of controlling the selective lighting of said keyboard.
4. An apparatus as claimed in one of the claims 1 to 3, characterized in that
- 15 said apparatus is a telephone terminal.
5. A keyboard with at least one key that allows light to pass through which indicates a label that admits of being modified, characterized in that the surface of said key is divided into two parts to which two different labels are associated, and in that it comprises selective lighting means for lighting either part.
- 20 6. A keyboard as claimed in claim 5, characterized in that said selective lighting means comprise:
 - two polarizing filters whose polarization planes are normal and which are associated to said key opposite said parts,
 - and two light sources, each light sources respectively emitting a polarized light
- 25 in one of said planes, and being selectively lit for lighting said key.
7. A keyboard as claimed in one of the claims 5 or 6, characterized in that said keyboard includes a selection key for selecting a mode of operation, said key permitting of controlling the selective lighting of said keyboard.
8. A method of modifying the label indicated on a key of a keyboard, said

key leaving light to pass through, characterized in that it comprises dividing the surface of said key into two parts to which are associated two different labels, and selectively lighting either part.

9. A modification method as claimed in claim 8, characterized in that, for
5 selectively lighting either part it comprises:

- the association of two polarizing filters whose polarization planes are perpendicular to each other to said key opposite said parts,
- the use of two light sources, each light source respectively emitting a polarized light in one of said planes,
- 10 - and the selective lighting of either said source to light said key.

10. A modification method as claimed in one of the claims 8 or 9, characterized in that it is implemented by activating a selection key on said keyboard, which key permits of controlling the selective lighting of said keyboard.

1/2

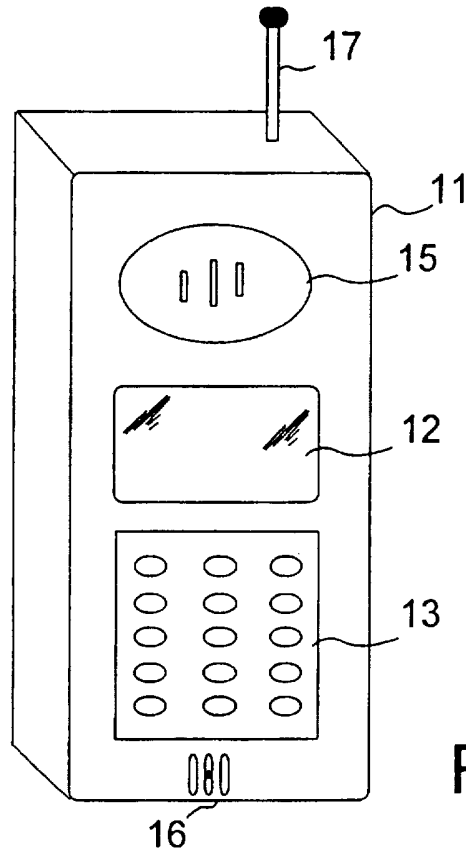

FIG. 1

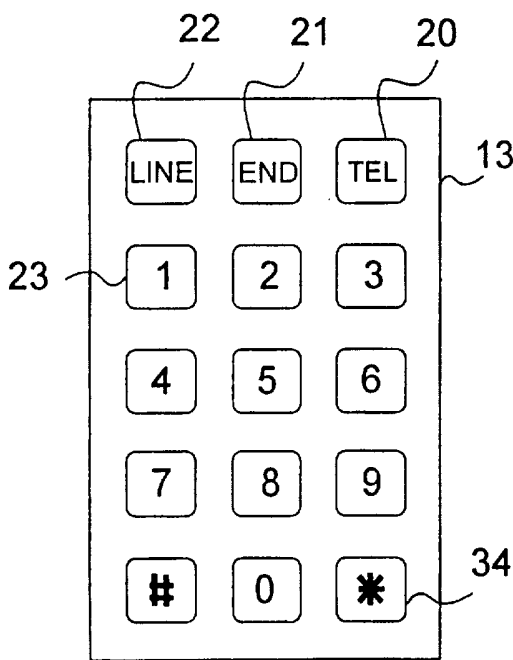

FIG. 2

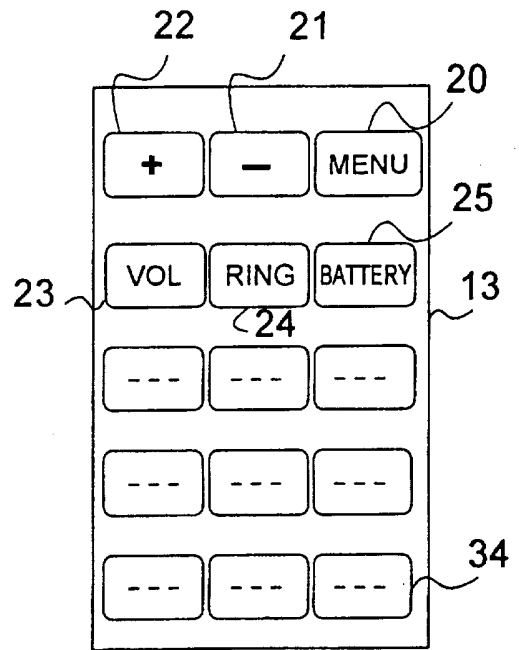

FIG. 3

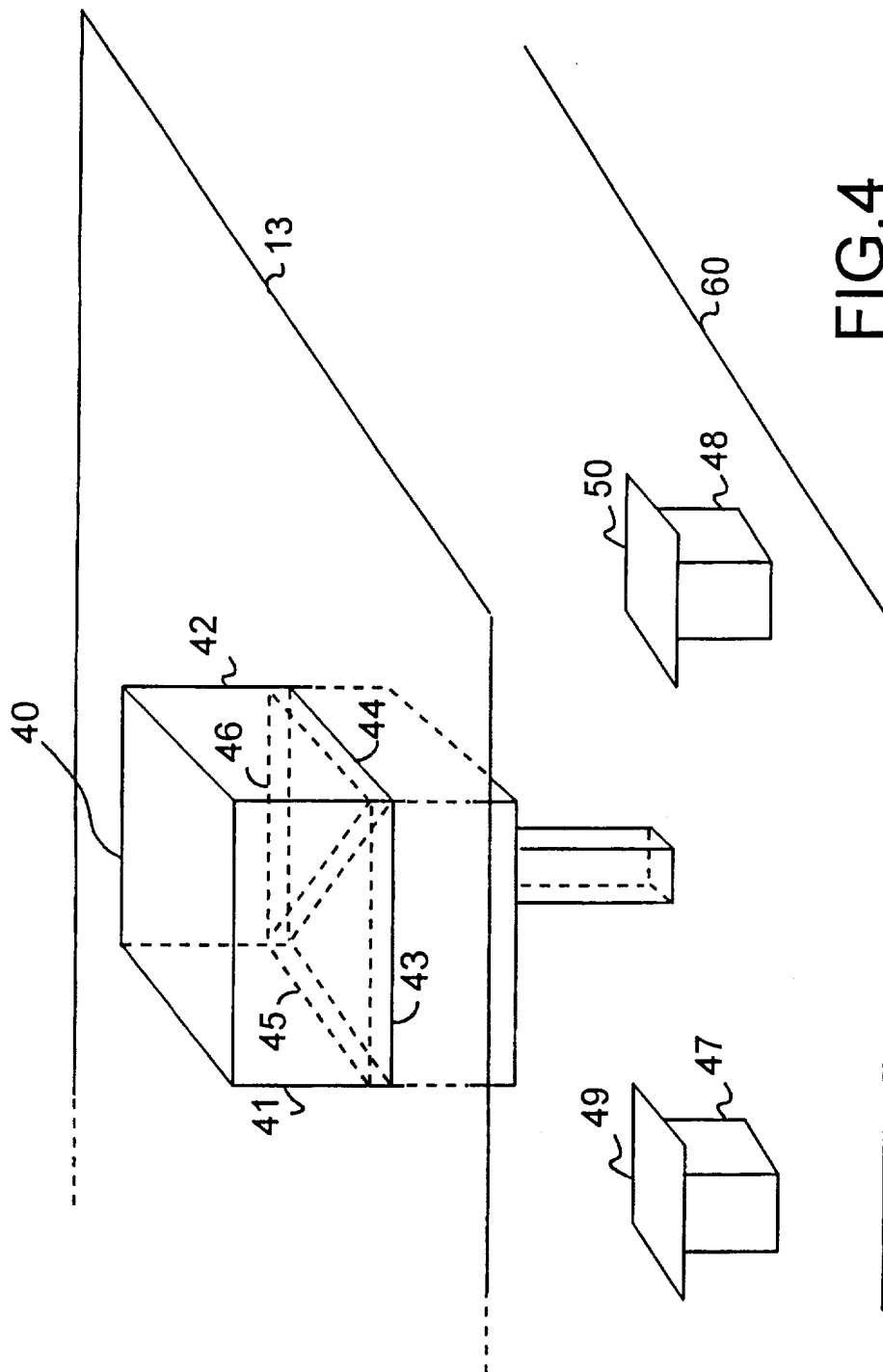

FIG.4

INTERNATIONAL SEARCH REPORT

Inter nal Application No
PCT/IB 97/00765

A. CLASSIFICATION OF SUBJECT MATTER
IPC 6 H01H13/70

According to International Patent Classification (IPC) or to both national classification and IPC

B. FIELDS SEARCHED

Minimum documentation searched (classification system followed by classification symbols)

IPC 6 H01H

Documentation searched other than minimum documentation to the extent that such documents are included in the fields searched

Electronic data base consulted during the international search (name of data base and, where practical, search terms used)

C. DOCUMENTS CONSIDERED TO BE RELEVANT

Category *	Citation of document, with indication, where appropriate, of the relevant passages	Relevant to claim No.
X	US 5 408 060 A (MUURINEN JARI) 18 April 1995	1,4
A	see column 3, line 11 - line 27 see column 6, line 16 - line 41; claims; figures 7-9	2,3
A	---	
A	FR 2 673 761 A (SYSTEMES AUDIO FREQUENCES) 11 September 1992 see page 4	1,4
A	---	
A	DE 32 35 752 A (SIEMENS AG) 29 March 1984 see claims; figure 1	1,2
A	---	
A	US 4 831 218 A (WRIGHT FORREST S) 16 May 1989 see figures 9,10	1,4

Further documents are listed in the continuation of box C.

Patent family members are listed in annex.

* Special categories of cited documents :

- *A* document defining the general state of the art which is not considered to be of particular relevance
- *E* earlier document but published on or after the international filing date
- *L* document which may throw doubts on priority claim(s) or which is cited to establish the publication date of another citation or other special reason (as specified)
- *O* document referring to an oral disclosure, use, exhibition or other means
- *P* document published prior to the international filing date but later than the priority date claimed

- *T* later document published after the international filing date or priority date and not in conflict with the application but cited to understand the principle or theory underlying the invention
- *X* document of particular relevance; the claimed invention cannot be considered novel or cannot be considered to involve an inventive step when the document is taken alone
- *Y* document of particular relevance; the claimed invention cannot be considered to involve an inventive step when the document is combined with one or more other such documents, such combination being obvious to a person skilled in the art.
- *&* document member of the same patent family

Date of the actual completion of the international search

20 August 1997

Date of mailing of the international search report

21.08.1997

Name and mailing address of the ISA

European Patent Office, P.B. 5818 Patentlaan 2
NL - 2280 HV Rijswijk
Tel. (+ 31-70) 340-2040, Tx. 31 651 cpo nl,
Fax: (+ 31-70) 340-3016

Authorized officer

Janssens De Vroom, P

INTERNATIONAL SEARCH REPORT

Information on patent family members

Int. onal Application No PCT/IB 97/00765
--

Patent document cited in search report	Publication date	Patent family member(s)	Publication date
US 5408060 A	18-04-95	DE 69213293 D DE 69213293 T EP 0508563 A JP 6111661 A	10-10-96 06-03-97 14-10-92 22-04-94
----- FR 2673761 A	11-09-92	NONE	-----
DE 3235752 A	29-03-84	NONE	-----
US 4831218 A	16-05-89	NONE	-----