



US00D893366S

(12) **United States Design Patent** (10) **Patent No.:** **US D893,366 S**  
**Dewitt et al.** (45) **Date of Patent:** **\*\* Aug. 18, 2020**

(54) **VEHICLE FRONT LOWER BUMPER COVER**

(71) Applicant: **Ford Global Technologies, LLC,**  
Dearborn, MI (US)

(72) Inventors: **David Dewitt,** Docklands (AU); **Todd Willing,** East Melbourne (AU); **Max Wolff,** Birmingham, MI (US); **Pedro Guarinon,** Melbourne (AU); **Mark Wright,** Nunawading (AU)

(73) Assignee: **Ford Global Technologies, LLC,**  
Dearborn, MI (US)

(\*\*) Term: **15 Years**

(21) Appl. No.: **29/659,497**

(22) Filed: **Aug. 9, 2018**

(51) **LOC (12) Cl.** ..... **12-16**

(52) **U.S. Cl.**  
USPC ..... **D12/169**

(58) **Field of Classification Search**  
USPC ..... D12/163, 169, 196, 184  
CPC ..... B60R 19/52; B60K 11/08; B62D 25/08;  
B62B 9/16  
See application file for complete search history.

(56) **References Cited**

**U.S. PATENT DOCUMENTS**

D570,751 S *	6/2008	Choi	.....	D12/169
D585,340 S *	1/2009	Sinkwitz	.....	D12/163
D618,143 S *	6/2010	Elliott	.....	D12/163
8,651,554 B1 *	2/2014	Patelczyk	.....	B62D 25/12 296/136.08
D749,475 S *	2/2016	Battams	.....	D12/169
D763,144 S *	8/2016	Platto	.....	D12/169
D768,547 S *	10/2016	Choi	.....	D12/169
D772,117 S *	11/2016	Davidson	.....	D12/169
D772,119 S *	11/2016	De Bono	.....	D12/169
D777,617 S *	1/2017	Platto	.....	D12/169
D813,113 S *	3/2018	Zurian	.....	D12/169

D840,294 S *	2/2019	Battams	.....	D12/169
D851,559 S *	6/2019	Thurber	.....	B62D 25/12 D12/169
D854,462 S *	7/2019	Lee	.....	B60R 19/00 D12/163
D854,982 S *	7/2019	Horie	.....	B60R 19/52 D12/169
D855,511 S *	8/2019	Smith	.....	B60K 11/08 D12/169
D856,200 S *	8/2019	Dewitt	.....	B60R 19/52 D12/163

(Continued)

**OTHER PUBLICATIONS**

Williams, Mark. "Ford's 2016 Ford Ranger Will Not Come to U.S." PickupTrucks.com, published Apr. 3, 2015 (Retrieved from the Internet Apr. 1, 2020). Internet URL: <https://news.pickuptrucks.com/2015/04/fords-2016-ford-ranger-will-not-come-to-us.html> (Year: 2015).\*

(Continued)

*Primary Examiner* — Jack Reickel  
*Assistant Examiner* — Rachel A Voorhies

(57) **CLAIM**

The ornamental design for a vehicle front lower bumper cover, as shown and described.

**DESCRIPTION**

FIG. 1 is a front elevational view of a vehicle front lower bumper cover, showing our new design;  
FIG. 2 is a left side elevational view thereof;  
FIG. 3 is a right side elevational view thereof;  
FIG. 4 is a top plan view thereof;  
FIG. 5 is a bottom plan view thereof;  
FIG. 6 is a bottom, front, and left side perspective view thereof; and,  
FIG. 7 is a top, front, and left side perspective view thereof.

**1 Claim, 7 Drawing Sheets**



(56)

**References Cited**

## U.S. PATENT DOCUMENTS

D861,551 S \* 10/2019 Grand ..... D12/169  
2006/0181088 A1 \* 8/2006 Cobble ..... B60R 19/52  
293/115  
2011/0291430 A1 \* 12/2011 Bailey ..... B60K 11/08  
293/115  
2016/0221522 A1 \* 8/2016 Abe ..... B60R 19/52  
2018/0186319 A1 \* 7/2018 Sertkaya ..... B60R 19/00

## OTHER PUBLICATIONS

Rall, Patrick. "A Ranger Raptor inspired by the F150 Raptor is a great idea." Torque News, published Jun. 13, 2017 (Retrieved from the Internet Apr. 1, 2020). Internet URL: <<https://www.torquenews.com/106/ranger-raptor-inspired-f150-raptor-great-idea>> (Year: 2017).\*

Willems, Steph. "Ford Bronco Will be More 4Runner Than Wrangler Competitor . . ." The Truth About Cars, published Jan. 11, 2017 (Retrieved from the Internet Apr. 1, 2020). Internet URL: <<https://www.thetruthaboutcars.com/2017/01/ford-source-dishes-details-upcoming-ranger-bronco-disappointment-reigns/>> (Year: 2017).\*

\* cited by examiner

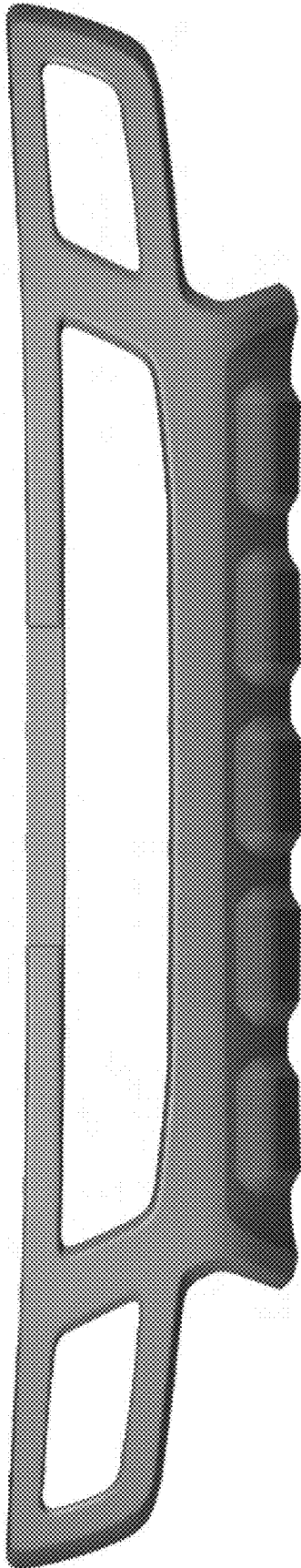

Fig. 1

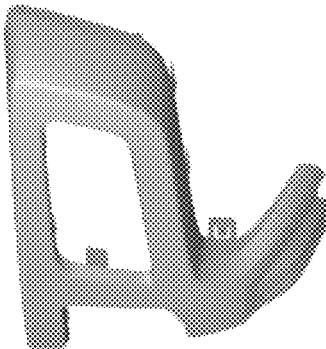

Fig. 2

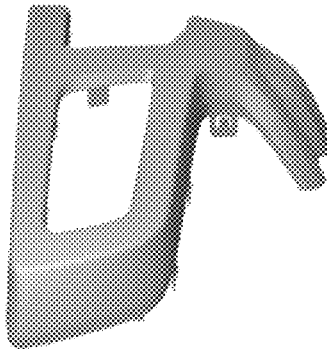

Fig. 3

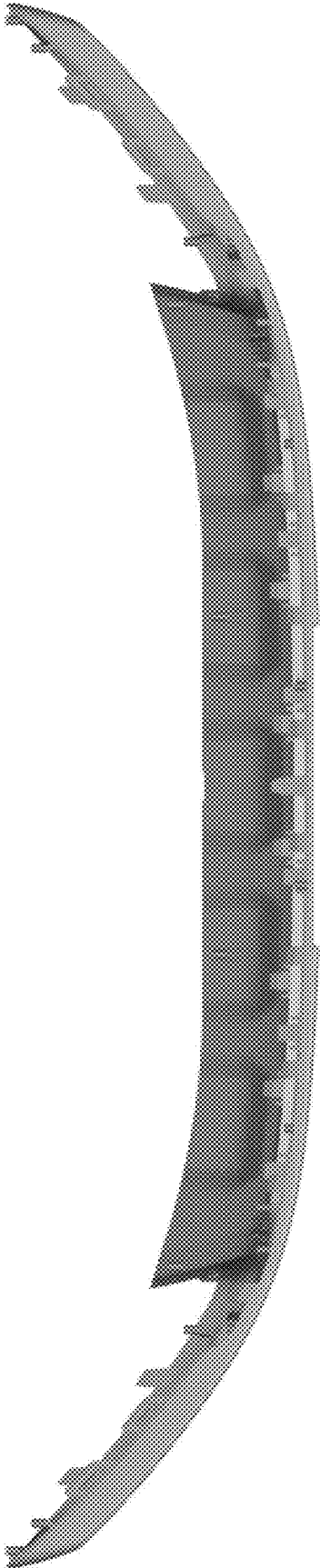
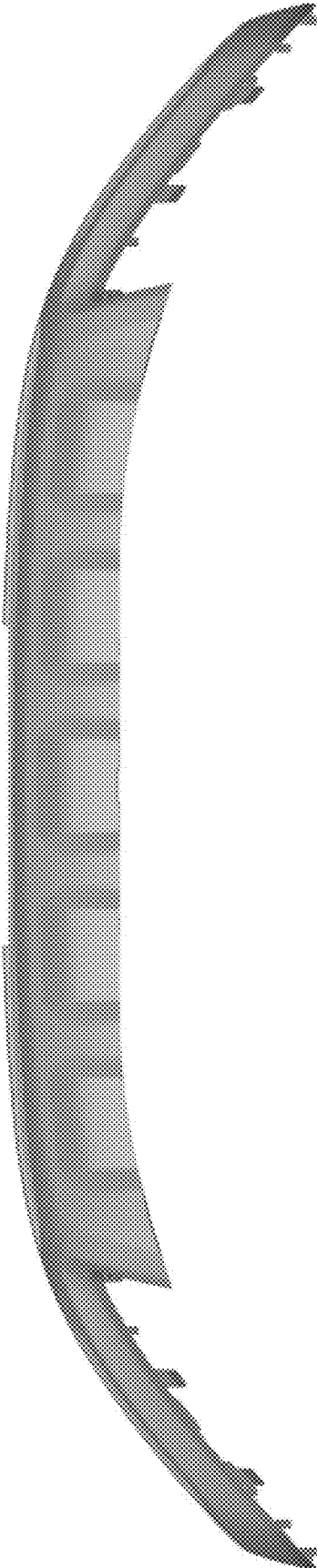

Fig. 4

Fig. 5



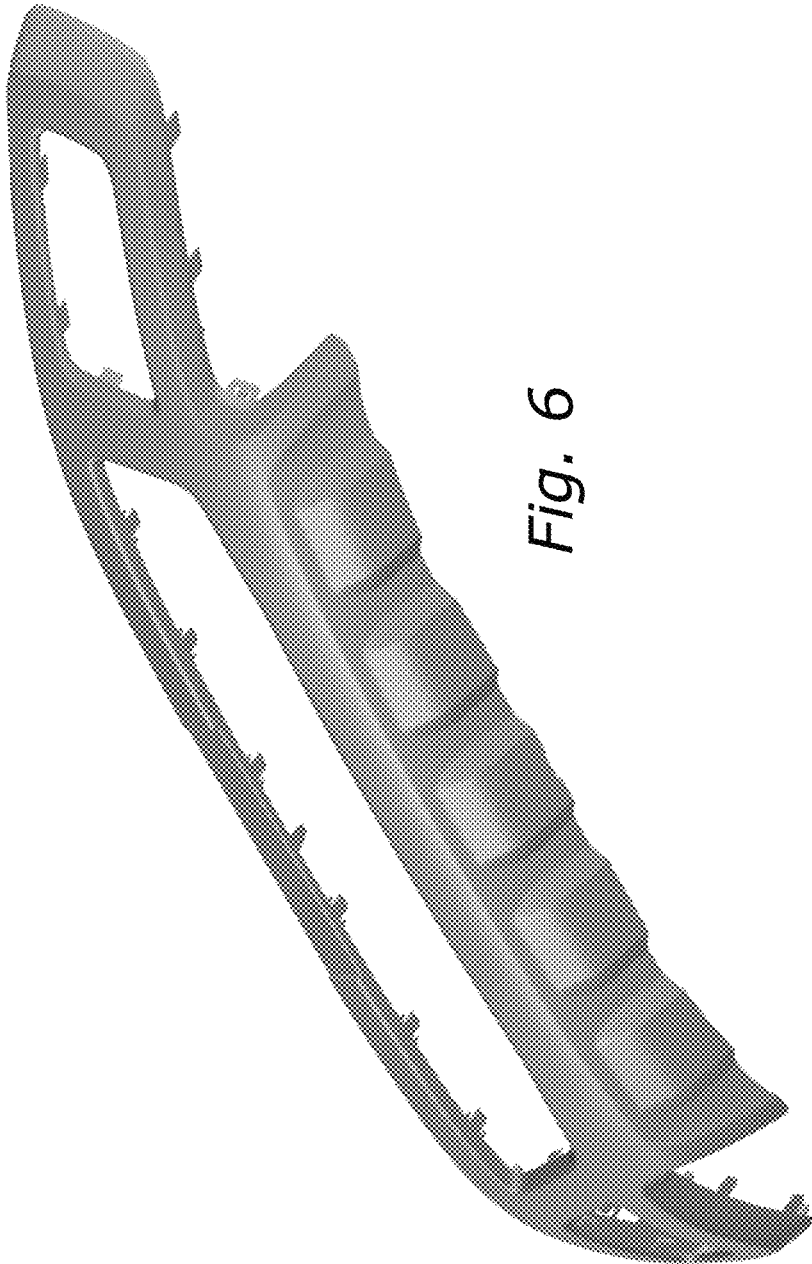

Fig. 6



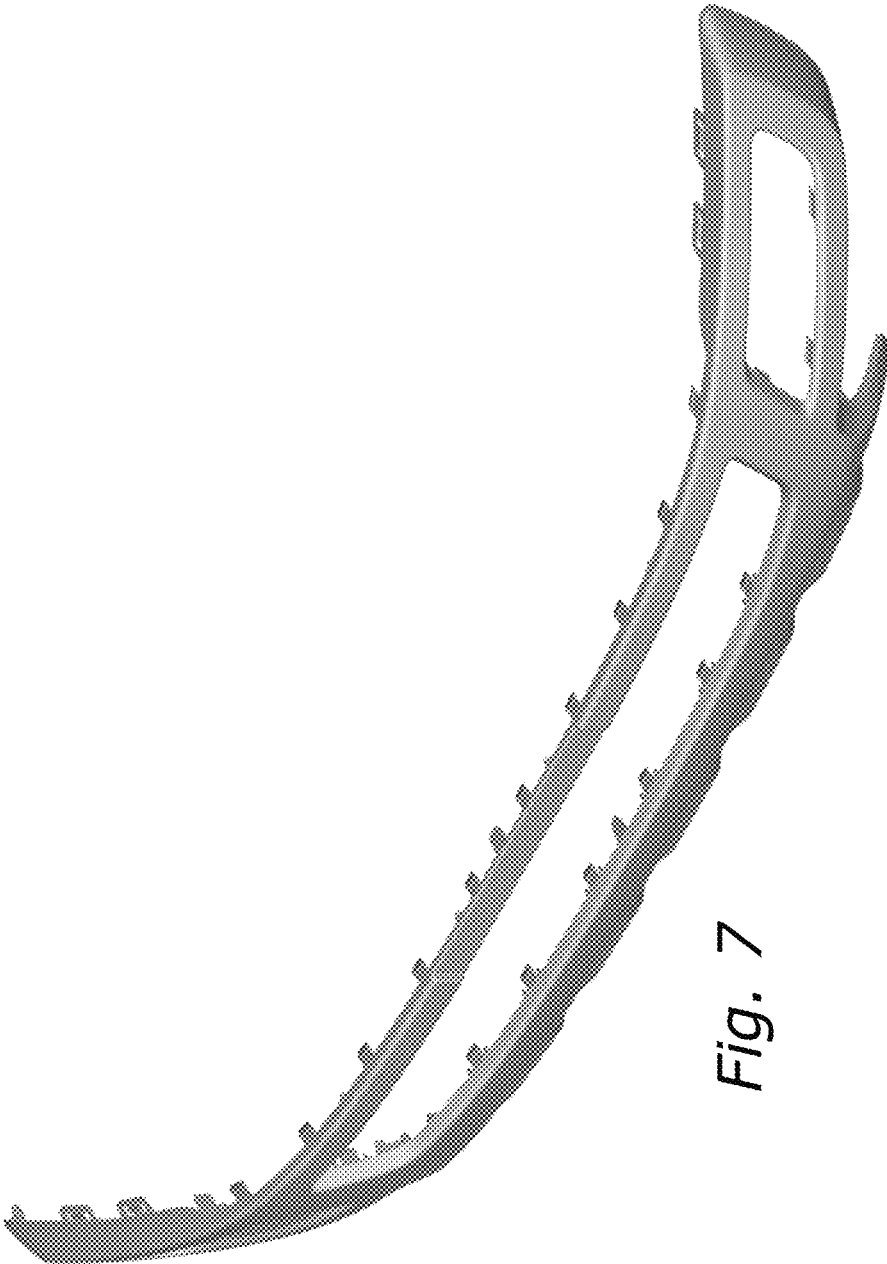

Fig. 7