

(19) **DANMARK**

(10) **DK/EP 3226960 T3**



(12) **Oversættelse af
europæisk patentskrift**

Patent- og
Varemærkestyrelsen

-
- (51) Int.Cl.: **A 61 N 1/05 (2006.01)** **A 61 N 1/36 (2006.01)** **A 61 N 1/372 (2006.01)**
- (45) Oversættelsen bekendtgjort den: **2019-06-11**
- (80) Dato for Den Europæiske Patentmyndigheds bekendtgørelse om meddelelse af patentet: **2019-03-06**
- (86) Europæisk ansøgning nr.: **15782067.1**
- (86) Europæisk indleveringsdag: **2015-10-12**
- (87) Den europæiske ansøgnings publiceringsdag: **2017-10-11**
- (86) International ansøgning nr.: **GB2015052984**
- (87) Internationalt publikationsnr.: **WO2016087813**
- (30) Prioritet: **2014-12-03 GB 201421448**
- (84) Designerede stater: **AL AT BE BG CH CY CZ DE DK EE ES FI FR GB GR HR HU IE IS IT LI LT LU LV MC MK MT NL NO PL PT RO RS SE SI SK SM TR**
- (73) Patenthaver: **Snoozeal Limited, 50 Woodgate, Leicester, Leicestershire LE3 5GF, Storbritannien**
- (72) Opfinder: **SAMA, Anshul, 22 Richmond Drive, Mapperley Park, Nottingham, Nottinghamshire NG3 5EL, Storbritannien**
- (74) Fuldmægtig i Danmark: **NORDIC PATENT SERVICE A/S, Bredgade 30, 1260 København K, Danmark**
- (54) Benævnelse: **ORAL MUSKELTRÆNING**
- (56) Fremdragne publikationer:
JP-A- 2014 158 607
US-A1- 2007 173 893
US-A1- 2010 204 747
US-A1- 2011 112 601
US-A1- 2014 135 868

DESCRIPTION

[0001] This invention relates generally to oral muscle training, particularly to oral muscle training devices. More specifically, although not exclusively, this invention relates to the training of muscles in the mouth for the treatment of sleep disordered breathing.

[0002] Snoring and sleep apnoea are considered as part of a range of conditions often termed as sleep disordered breathing (SDB), with symptoms relating to disordered breathing patterns during sleep. SDBs are not only a nuisance, but they can also result in health problems, for example frequent waking from sleep, light sleeping, strain on the heart, low oxygen levels in the blood, headaches and fatigue.

[0003] The breathing passage of humans between the back of the nose and mouth, to the level of the larynx, is a collapsible tube. It has been observed that collapse of the breathing passage occurs at a positive airway pressure in individuals who snore and/or suffer from sleep apnoea syndrome and at a negative airway pressure in individuals who do not.

[0004] In an effort to address this phenomenon, treatments have been developed which include using a continuous positive airway pressure device to keep the breathing passage open or wearing a mandibular advancement device to hold the jaw and tongue forward in order to increase the space at the back of the throat.

[0005] These devices can cause discomfort, they address the symptoms only temporarily, rather than addressing the underlying cause, and they must be used during sleep on an ongoing basis. As a result, users find it difficult to fall asleep and compliance is therefore low. It would therefore be desirable to provide a treatment that does not require the regular use of such devices during sleep and that addresses the underlying cause for the condition.

[0006] Recent research studies have shown that implanting electrical nerve stimulators into the tongue and diaphragm are effective in the treatment of obstructive sleep apnoea. This involves intrusive surgery to implant sensors and electrodes on nerves in these areas. The device identifies an episode of obstruction using the sensors and stimulates the tongue nerve to cause contraction to relieve the obstructive event. As with pacemakers, this approach leads to maintenance and other complications, such as battery replacement, risks associated with electrical fields and issues related to external security detection devices.

[0007] In addition, stimulation only occurs during an obstructive episode during sleep; it does not address the underlying cause of the condition.

[0008] Devices of the prior art include that shown in US2014/135868 A1, which describes a device for electrical stimulation of the sublingual surface of the tongue i.e. the upper pharyngeal dilator muscle, the genioglossus and base-of-tongue muscles for the treatment of Obstructive Sleep Apnea (OSA). Additionally, US2007/173893 A1 describes a device for

preventing OSA by providing electrical stimulation to the genioglossus muscle and the muscles of the upper airway (pharynx). JP2014 158607 A discloses a device with electrodes for providing electrical stimulation to the pharynx and pharyngeal region.

[0009] It is therefore a first non-exclusive object of the invention to provide a treatment system, preferably to be used in an awake state, that provides a sustainable reduction in disordered breathing patterns during sleep. It is a further, more general object of the invention to provide a treatment system and device that is more effective in at least one respect than existing systems and devices for the treatment of SDBs.

[0010] Accordingly, a first aspect of the invention provides an electrical stimulation device for training one or more oral muscles, for example a trans mucosal neuromuscular electrical stimulation device, the device comprising a mouthpiece, electrode means associated with the mouthpiece and electrical circuitry operatively connected to the electrode means, characterised in that the mouthpiece (3; 103) comprises a pair of arms (131) joined together at one end and diverging from one another with at least one flange (132) extending inwardly from at least one arm, the at least one flange being shaped to cooperate or approximate or accommodate a dorsal tongue surface, the at least one flange (132) includes the electrode means (132a) associated therewith for providing, in use, via the electrode means electrical stimulation to one or more palate and/or tongue muscles via the dorsal tongue surface to increase resting muscle tone and/or muscle tone during sleep.

[0011] When a person is awake, the collapsible segment of the breathing passage is kept open due to the tone of the muscles that control this area. When a person is asleep, this muscle tone reduces significantly. Evidence has shown that this reduction of muscle tone is significantly greater in patients who suffer from obstructive sleep apnoea, less so in those who snore and notably less in individuals who suffer from neither of these disorders.

[0012] Research has demonstrated that increasing the pharyngeal muscle activity or tone reduces the collapsibility of the airway and the present invention is based on the realisation that electrical stimulation, particularly neuromuscular electrical stimulation, can be used to stimulate the muscles of the tongue and/or palate and/or the sensory nerves to improve muscle power and tone recovery.

[0013] The device or electrical circuitry is preferably configured to provide a current, for example an electric current or impulse current, such as a biphasic electric current or impulse current.

[0014] An electrical stimulation device for training one or more oral muscles, for example a trans mucosal neuromuscular electrical stimulation device, the device comprising a mouthpiece, electrode means associated with the mouthpiece and electrical circuitry operatively connected to the electrode means, wherein the device or electrical circuitry is configured to provide, in use, via the electrode means a biphasic electric impulse current.

[0015] By providing a biphasic electric impulse current, the tongue and/or palate muscles contributing to the collapsibility of the airway can be stimulated along with the sensory nerves to increase resting muscle tone and muscle tone during sleep.

[0016] The current is preferably a biphasic symmetrical current, but it may additionally or alternatively be a biphasic asymmetrical current that may either be balanced or unbalanced. The device or electrical circuitry may be configured to provide, in use, via the electrode means an electric current with a frequency of between 5 and 150 Hz.

[0017] An electrical stimulation device for training one or more oral muscles is provided, for example a trans mucosal neuromuscular electrical stimulation device, the device comprising a mouthpiece, electrode means associated with the mouthpiece and electrical circuitry operatively connected to the electrode means, wherein the device or electrical circuitry is configured to provide, in use, via the electrode means a biphasic electric impulse current with a frequency of between 5 and 150 Hz.

[0018] The electric current may comprise a frequency of between 10 and 140 Hz, for example between 15 and 130 Hz, preferably between 20 and 120 Hz. Preferably, the electric current comprises a frequency of between 20 and 50 Hz and/or between 50 and 120 Hz.

[0019] The device or electrical circuitry may be configured to provide two or more currents, for example a first current and/or a second current, which second current may be different from and/or configurable or settable independently from the first current. At least one, e.g. both, of the first and/or second current may comprise a biphasic current, each of which is preferably symmetrical, but may be asymmetrical and either balanced or unbalanced. At least one of the first and/or second current may comprise a frequency of between 5 and 150 Hz, for example between 10 and 140 Hz, e.g. between 15 and 130 Hz, preferably between 20 and 120 Hz. In some embodiments, one or the currents may comprise a frequency of between 20 and 50 Hz and/or the other current may comprise a frequency of between 50 and 120 Hz.

[0020] The inventors believe that the application of an electric current in one or each of these two frequency ranges is particularly suited to targeting palate and tongue muscles contributing to the collapsibility of the airway.

[0021] The device or electrical circuitry may be configured to provide, in use, the or at least one or each electrical current to one or more palate and/or tongue muscles through the oral mucosa to increase resting muscle tone and/or muscle tone during sleep. In some embodiments, the device is configured to provide, in use, the electrical current, e.g. the first electrical current, to one or more palate muscles. The device is configured to provide, in use, the electrical current, e.g. the second electrical current, to one or more tongue muscles via the dorsal tongue surface. Additionally, the device may be configured to provide, in use, the electrical current, e.g. the first or second electrical current, to one or more tongue muscles via the underside of the tongue.

[0022] In embodiments, the mouthpiece may comprise more than one, e.g. two or more, appendages or flanges which may extend from the one or more arms, e.g. for contacting one or more oral muscles. At least one arm and/or at least one appendage or flange may be flat or planar, for example with major surfaces. Optionally, the pair of arms may each comprise one or more appendages or flanges. In some embodiments, the mouthpiece comprise a pair of arms that may extend at least partially alongside each other and/or at an angle relative to one another and/or parallel to each other. For example, the mouthpiece may comprise a pair of arms joined together at one end and diverging from one another, for example in a substantially V-shape or U-shape or horseshoe shape.

[0023] The one or more appendages or flanges may extend inwardly of the pair of arms, e.g. from one arm and toward the other arm. In some embodiments, each arm comprises at least one appendage or flange, for example opposite one another and/or extending toward one another. In embodiments, each arm comprises two or more appendages or flanges, for example an appendage or flange extending from a free end of each arm and/or an appendage or flange extending from an intermediate portion of each arm.

[0024] At least one appendage or flange may be curved, e.g. a flat curved shape or member, and/or extend upwardly or downwardly or out of the plane of the mouthpiece or at least one arm thereof. At least one appendage or flange is shaped to cooperate or approximate or accommodate a dorsal tongue surface. At least one appendage or flange may be shaped to cooperate or approximate or accommodate a sublingual tongue surface. In embodiments, the mouthpiece comprises at least one appendage or flange that is shaped to cooperate or approximate or accommodate a dorsal tongue surface and at least one appendage or flange that is shaped to cooperate or approximate or accommodate a sublingual tongue surface. In embodiments having a pair of arms, each arm may comprise an appendage or flange shaped to cooperate or approximate or accommodate a dorsal tongue surface and an appendage or flange that is shaped to cooperate or approximate or accommodate a sublingual tongue surface.

[0025] At least one of the appendages or flanges comprises one or more electrodes or series thereof. At least one electrode or series of electrodes may be adjacent and/or associated with and/or exposed at a surface, e.g. a major surface, of the at least one appendage or flange. In embodiments, at least one of the appendages or flanges comprises electrodes associated with each of its major surfaces. The electrodes associated with one of the major surfaces may be isolated and/or controllable independently from another or the other major surface thereof. Additionally or alternatively, the electrodes of or associated with one appendage or flange may be isolated and/or controllable independently from at least one other appendage or flange. In embodiments, the mouthpiece may comprise a pair of arms joined together at one end and diverging from one another to provide a substantially horseshoe shape with one or more flanges extending inwardly from at least one arm, the or each flange comprising electrode means. The mouthpiece may comprise a pair of flanges each extending inwardly from a respective arm, which flanges are shaped to accommodate a dorsal tongue surface. The mouthpiece may comprises a pair of flanges each extending inwardly from a respective arm,

which flanges are shaped to accommodate a sublingual tongue surface. Each of the pair of flanges may be shaped to accommodate a dorsal tongue surface extends from at or adjacent a free end of the arm and/or each of the pair of flanges may be shaped to accommodate a sublingual tongue surface extends from an intermediate portion of the arm.

[0026] An electrical stimulation device for training one or more oral muscles is provided, for example a trans mucosal neuromuscular electrical stimulation device, the device comprising a mouthpiece, electrode means associated with the mouthpiece and electrical circuitry operatively connected to the electrode means, wherein the mouthpiece comprises a pair of arms joined together at one end and diverging from one another to provide a substantially horseshoe shape with one or more flanges extending inwardly from at least one arm, the or each flange including at least part of the electrode means associated therewith for providing electrical stimulation to one or more palate and/or tongue muscles.

[0027] An electrical stimulation mouthpiece for training one or more oral muscles is provided, for example a trans mucosal neuromuscular electrical stimulation mouthpiece, the mouthpiece comprising a pair of arms joined together at one end and diverging from one another to provide a substantially horseshoe shape with one or more flanges extending inwardly from at least one arm, wherein the or each flange includes electrode means associated therewith for providing electrical stimulation to one or more palate and/or tongue muscles.

[0028] The mouthpiece may comprise a gripping base, which may comprise an enlarged end, e.g. an enlarged free end, which may be connected or secured to, e.g. formed integrally with, the mouthpiece or a body or one or more or each arm thereof, for example by a necked portion.

[0029] The electrode means preferably comprises at least one anode and at least one cathode, for example two or more anodes and/or two or more cathodes, e.g. a plurality of anodes and a plurality of cathodes. At least part of the electrode means, for example one or more or each or all of the electrodes, may be mounted to or on or within and/or at least partially housed or contained within the mouthpiece. In some embodiments, the mouthpiece comprises a shield or shield means, for example on one side of the electrode means, e.g. for inhibiting or preventing the electrical stimulation or current from being applied or provided by or at or from one side of the mouthpiece. Suitable materials for the shield or shield means will be apparent to those skilled in the art.

[0030] In embodiments, the electrode means is configured or operable to provide or apply, e.g. selectively, the electrical stimulation or current at or from at least one or each or both sides, for example by including the or a shielding means or shield between a first set or series of electrode means or electrodes and a second set or series of electrode means or electrodes. In some embodiments, the first electrical current is provided or applied at or from a first side, e.g. major side, of the mouthpiece and/or by the first set or series of electrode means or electrodes. Additionally or alternatively, the second electrical current may be provided or applied at or from a second side, e.g. major side, of the mouthpiece and/or by the second set

or series of electrode means or electrodes. In other embodiments, the first and second electrical currents may be provided or applied from at least one or each or both sides.

[0031] The mouthpiece may be insertable into the mouth and held in place, e.g. manually. The mouthpiece may be at least partially flattened and/or substantially flat and/or paddle-shaped, for example with at least one flat and/or major surface, preferably two flat major surfaces. In some embodiments, the device may include a handle to which the mouthpiece may be connected or mounted or attached, for example rigidly and/or releasably, e.g. to enable the mouthpiece to be inserted and/or held, in use, within one or more locations or positions and/or orientations within the mouth. In some embodiments, the mouthpiece is free of any mounting means for mounting or securing it to or in or within the mouth of a user.

[0032] In embodiments, the mouthpiece may include a mounting means. The mounting means may be for mounting the mouthpiece to an upper part or portion of the mouth, for example such that the mouthpiece or the or a first side or surface thereof is or may be in contact with and/or adjacent one or more palate muscles and/or the roof of the mouth and/or the mouthpiece or the or a second side or surface thereof is or may be in contact with and/or adjacent one or more tongue muscles, for example a dorsal tongue surface. Additionally or alternatively, the mounting means may be for mounting the mouthpiece to a lower part or portion of the mouth, for example such that the mouthpiece or the or a first side or surface thereof is or may be in contact with and/or adjacent one or more tongue muscles, for example a sublingual tongue surface. In embodiments, the device comprises a first mouthpiece with mounting means for mounting it to an upper part or portion of the mouth and a second mouthpiece for mounting it to a lower part or portion of the mouth.

[0033] The device or handle may comprise an input means or activator, which may include one or more input devices, buttons and/or push buttons and/or switches and/or dials or the like, e.g. for enabling or activating or initiating the electrical stimulation or current. The device or handle may comprise a power source and/or a cable connectable to a power source. In some embodiments, the device comprises a main body that includes or incorporates or provides the handle and/or which includes or houses the power source, which may comprise a rechargeable power source or one or more batteries that may be rechargeable, and/or which can either include the cable or be operatively, e.g. inductively, connectable to a charging station that includes or incorporates the cable, for example to enable the power source to be recharged. The device may include the charging station.

[0034] In some embodiments, the device comprises an adjustment means or adjuster, e.g. a frequency adjustment means or adjuster, for adjusting the frequency of the current or of the first and/or second currents, for example a respective first and second current frequency adjustment means or adjuster for adjusting the frequency of the current, e.g. between one of the aforementioned ranges. In embodiments, the adjustment means or adjuster is a step-wise adjustment means or adjuster and/or is configured to enable a user to select from one of two or more, e.g. three, four or five, predetermined frequency settings. The device may be operable or configured to provide the first and second currents simultaneously and/or

concurrently and/or in parallel. Additionally or alternatively, the device may be operable or configured to provide the first and second currents in series and/or in sequence and/or in succession.

[0035] The current or at least one, e.g. both, of the first and/or second current may comprise an impulse current. The pulse duration of the or each impulse current may be between 50 and 1000 μs , for example between 100 and 900 μs , e.g. between 150 and 800 μs , preferably between 200 and 700 μs . Preferably, the or a further adjustment means or adjuster, e.g. an pulse duration adjustment means or adjuster, of the device is provided for adjusting the pulse duration, for example between one of the aforementioned ranges.

[0036] The electrical stimulation or current or first and/or second currents may comprise an intensity or current amplitude, which is preferably selected or selectable to provide maximum contraction of the muscles being treated. By way of example, the intensity or amplitude may comprise approximately 10 mA, for example between 1 and 100 mA, such as between 5 and 50 mA, for example between 5 and 15 mA or between 7 and 25 mA, e.g. between 8 and 12 mA. The or a further adjustment means or adjuster, e.g. an intensity or amplitude adjustment means or adjuster, may be provided for adjusting the intensity or amplitude, for example from 0 to 500 mA or from 0 to 250 mA or from 0 to 200 mA or from 0 to 150 mA or from 0 to 100 mA.

[0037] In some embodiments, the device is configured or programmed to provide the electrical stimulation or electric current or the first and/or second electric current for a predetermined period, which may comprise between 1 minute and 1 hour, for example between 5 and 30 minutes, preferably between 10 and 20 minutes. The or a further adjustment means or adjuster, e.g. a treatment duration adjustment means or adjuster, may be provided for adjusting the treatment duration, for example from 0 to 10 hours or from 0 to 5 hours or from 0 to 1 hour or from 0 to 30 minutes.

[0038] The device may comprise a control means, which may be programmed or programmable, for example to control one or more features of the electrical stimulation or current or currents, for example according to a predetermined treatment regime. The control means may comprise a control system and/or a controller and/or may comprise or be at least partially comprised in the electrical circuitry. The control means may comprise at least part of the adjustment means or adjuster, e.g. one or more of the frequency and/or pulse duration and/or intensity and/or amplitude and/or treatment duration adjustment means or adjusters.

[0039] In some embodiments, the input means may be for or configured or operable to control and/or adjust one or more features of the electrical stimulation or electric current or the first and/or second electric current, for example the frequency and/or pulse duration and/or intensity and/or amplitude and/or treatment duration. Additionally or alternatively the device or input means may comprise an interface or connection means such as a connector or receptacle for connecting the device or control means to another device, such as a personal computer or a handheld device, which may be operable to program and/or control and/or

adjust one or more of the aforementioned features.

[0040] The device or control means or adjustment means may be configured or programmed to control one or more features of the electrical stimulation or electric current or the first and/or second electric current, for example in a predetermined manner and/or according to a predetermined treatment regime. The device or control means may be operable or programmable to create and/or alter the predetermined treatment regime, for example by a device to which the electrical stimulation device is connected, e.g. via the input means.

[0041] An exemplary computer program element is provided comprising computer readable program code means for causing a processor to execute a procedure to implement a method or treatment regime comprising providing electrical stimulation to one or more palate and/or tongue muscles, through the oral mucosa to increase resting muscle tone and/or muscle tone during sleep.

[0042] An exemplary method or treatment regime is provided, e.g. for training one or more oral muscles such as by trans mucosal neuromuscular electrical stimulation, the method comprising providing or applying electrical stimulation to one or more palate and/or tongue muscles, through the oral mucosa to increase resting muscle tone and/or muscle tone during sleep.

[0043] For the avoidance of doubt, any of the features described herein apply equally to any aspect of the invention.

[0044] The method or treatment regime may comprise providing or applying a current, for example an electric current or impulse current, such as a biphasic electric current or impulse current, e.g. to the one or more oral muscles.

[0045] An exemplary method or treatment regime is provided, e.g. for training one or more oral muscles such as by trans mucosal neuromuscular electrical stimulation, the method comprising providing or applying via electrode means, a biphasic electric current, for example biphasic electric impulse current, to one or more oral muscles, e.g. palate and/or tongue muscles, through the oral mucosa.

[0046] The method or treatment regime may comprise providing or applying a first current and/or a second current, which second current may be different from the first current. The current or at least one, e.g. both, of the first and/or second current may comprise an alternating current. The or at least one of the or each current may comprise a frequency of between 5 and 150 Hz, for example between 10 and 140 Hz, e.g. between 15 and 130 Hz, preferably between 20 and 120 Hz, more preferably between 20 and 50 Hz and/or between 50 and 120 Hz. In some embodiments, the first current comprises a frequency of between 20 and 50 Hz and/or the second current comprises a frequency of between 50 and 120 Hz.

[0047] In embodiments, phases of the biphasic current, or the first and second currents, may

be applied simultaneously and/or concurrently. In some embodiments, phases of the biphasic current, or the first and second currents, may be applied in series and/or in sequence and/or in succession.

[0048] The current or at least one, e.g. both, of the first and/or second current may comprise an impulse current. The pulse duration of the or each impulse current may be between 50 and 1000 μ s, for example between 100 and 900 μ s, e.g. between 150 and 800 μ s, preferably between 200 and 700 μ s.

[0049] The electrical stimulation or current or first and/or second currents may comprise an intensity or current amplitude, which is preferably selected or selectable to provide maximum contraction of the muscles being treated. By way of example, the intensity or amplitude may comprise approximately 10 mA, for example between 1 and 100 mA, such as between 5 and 50 mA, for example between 5 and 15 mA or between 7 and 25 mA, e.g. between 8 and 12 mA.

[0050] The method or treatment regime may comprise providing or applying the electrical stimulation or electric current or the first and/or second electric current for a predetermined period, which may comprise between 1 minute and 1 hour, for example between 5 and 30 minutes, preferably between 10 and 20 minutes.

[0051] The method or treatment regime may comprise providing or applying the electrical stimulation or electric current or the first and/or second electric current for a first predetermined period to a first muscle or group of muscles and/or to an upper or dorsal surface of the tongue. The first muscle or group of muscles may include one or more palate and/or tongue muscles, e.g. one or more of the intrinsic surface muscles, the uvular muscle, the levator veli palatini muscle and the palatopharyngeus muscle.

[0052] Additionally or alternatively, the method or treatment regime may comprise providing or applying the electrical stimulation or electric current or the first and/or second electric current for a second predetermined period to a second muscle or group of muscles and/or to the underside of the tongue, e.g. sublingually. The second muscle or group of muscles may include one or more palate and/or tongue muscles, one or more of which may be different from the first muscle or group of muscles e.g. the genioglossus muscle. By way of example, the first predetermined period may comprise between five and thirty minutes, for example five or ten or fifteen or twenty or thirty minutes and/or the second predetermined period may comprise between five and thirty minutes, for example five or ten or fifteen or twenty or thirty minutes.

[0053] Additionally or alternatively, the method or treatment regime comprises carrying out one or more of the aforementioned steps at predetermined intervals, which may comprise between one and ten times per day or any number therebetween, for example twice per day. Additionally or alternatively, the method or treatment regime comprises carrying out one or more of the aforementioned steps over a predetermined treatment period, which may comprise between one and twelve weeks, for example between two and ten weeks, e.g.

between five and eight weeks, such as six weeks.

[0054] The method or treatment regime may comprise adjusting one or more features of the electrical stimulation or electric current or the first and/or second electric current, for example the frequency and/or pulse duration and/or intensity and/or amplitude and/or treatment duration. The adjustment may be carried out using an input means, such as one or more push buttons and/or dials or the like or via an interface or connection means such as a connector or receptacle by a device, such as a personal computer or a handheld device.

[0055] The method or treatment regime comprises a first, e.g. treatment, period, for example during which the electrical stimulation or electric current or the first and/or second electric current is or are provided or applied, e.g. to build resting muscle tone and/or muscle tone during sleep. The method or treatment regime may also comprise a second, e.g. maintenance, period, for example during which one or more features of the electrical stimulation or electric current or the first and/or second electric current is adjusted or changed, e.g. with respect to the first period, e.g. to maintain resting muscle tone and/or muscle tone during sleep. The first period may comprise a first regime and/or the second period may comprise a second regime, e.g. different from the first regime.

[0056] In an exemplary example, the method or treatment regime comprises providing or applying electrical stimulation to the one or more oral muscles for 10 to 20 minutes, twice per day for six weeks, for example to build resting muscle tone and/or muscle tone during sleep. Additionally or alternatively, the method or treatment regime may comprise providing or applying electrical stimulation to the one or more oral muscles for 10 to 20 minutes, once per day on an ongoing basis, for example to maintain resting muscle tone and/or muscle tone during sleep.

[0057] An exemplary method or treatment regime is provided, e.g. for training one or more oral muscles such as by sensory stimulation, the method comprising providing or applying a vibratory stimulation to one or more oral muscles, e.g. palate and/or tongue muscles. The method may further comprise any one or more features of the method described above.

[0058] An exemplary computer program element comprising computer readable program code means for causing a processor to execute a procedure to implement the aforementioned method or treatment regime is provided. A yet further aspect of the invention provides the computer program element embodied on a computer readable medium.

[0059] An exemplary computer readable medium having a program stored thereon, where the program is arranged to make a computer execute a procedure to implement the aforementioned method or treatment regime is provided.

[0060] An exemplary control means or control system or controller comprising the aforementioned computer program element or computer readable medium or for controlling a treatment regime to train one or more oral muscles, such as by trans mucosal neuromuscular

electrical stimulation, for example for controlling the method described above is provided.

[0061] Within the scope of this application it is expressly envisaged that the various aspects, embodiments, examples and alternatives set out in the preceding paragraphs, in the claims and/or in the following description and drawings, and in particular the individual features thereof, may be taken independently or in any combination. Features described in connection with one aspect or embodiment of the invention are applicable to all aspects or embodiments, unless such features are incompatible.

[0062] Embodiments of the invention will now be described by way of example only with reference to the accompanying drawings in which:

Figure 1 is a perspective view of an electrical stimulation device;

Figure 2 is a perspective view of the main body of the device of Figure 1;

Figure 3 is a perspective view of the mouthpiece of the device of Figure 1;

Figure 4 is a perspective view of the charging station of the device of Figure 1;

Figure 5 is a schematic of a human mouth showing the palatoglossus and surface of the tongue;

Figure 6 is a schematic illustrating the extrinsic tongue muscles of a human tongue;

Figure 7 is a schematic illustrating the intrinsic tongue muscles of a human tongue;

Figure 8 is another schematic of a human mouth showing the muscles of the palate;

Figure 9 is a schematic illustrating further muscles of the palate;

Figure 10 is a top view of the mouthpiece of an electrical stimulation device according to an embodiment of the invention; and

Figure 11 is a side view of the mouthpiece of Figure 10.

[0063] Referring now to Figures 1 to 4, there is shown an electrical stimulation device 1 including a main body 2, a mouthpiece 3 and a charging station 4. The main body 2 serves as a handle, is substantially cylindrical in this embodiment and includes a first, upper end 20 with a male connector 21 having a projection 22 on each of its side to provide a bayonet fitting and an electrical socket 23 for receiving an electrical connector (not shown) of the mouthpiece 3. On its front surface, the main body 2 also includes an ON/OFF button 2a, four dials 24, 25, 26, 27, a USB port 28 and a second, lower end 29 with a receptacle (not shown) for receiving a projection 41 of the charging station 4.

[0064] The main body 2 also contains batteries (not shown) and electrical circuitry including

inverters for converting the direct current of the batteries into two separate symmetrical biphasic currents. The first dial 24 is operable to adjust the current amplitude of a first biphasic current from 0 to 100 mA. The second dial 25 is operable to adjust the current amplitude of a second biphasic current from 0 to 100 mA. The third dial 26 is operable to adjust the duration of the period during which the first biphasic current is supplied from 1 to 30 minutes.. The fourth dial 27 is operable to adjust the duration of the period during which the second biphasic current is supplied from 1 to 30 minutes.

[0065] The USB port 28 is configured to enable the device 1 to be connected to a personal computer (not shown) to program one or more characteristics of the first and second biphasic currents independently. In this embodiment, the frequency of the first biphasic current is set at a value between 20 and 50 Hz, the second biphasic current is set at a value between 50 and 120Hz and the pulse duration of each biphasic current is set at a value between 200 and 700 μ s. The personal computer (not shown) may also incorporate control software operable to override the dials 24, 25, 26, 27. The software may be programmed to apply biphasic currents having predetermined characteristics independent from one another, such as amplitudes, frequencies and pulse durations and for a predetermined period of time. It is further envisaged that the device 1 could incorporate a memory on which is stored such predetermined characteristics, which may be modified by connecting a personal computer (not shown) to the device 1 via the USB port 28. In such embodiments, the dials may be omitted or configured to adjust the aforementioned characteristics from their pre-programmed values. In some embodiments, it is envisaged that more or less functionality is provided by manual dials, buttons and the like.

[0066] The mouthpiece 3 includes a cylindrical base 30 and a substantially flat, paddle-shaped contact portion 31 formed integrally with an upper end of the base 30 and having first and second major surfaces 32, 33. The base 30 includes a receptacle (not shown) at its lower end 34 with an electrical connector (not shown) for receipt within the electrical socket 23 of the main body 2. The mouthpiece 3 also includes electrical circuitry (not shown) feeding a respective series of electrodes 32a, 33a beneath each of the major surfaces 32, 33. The electrode series 32a, 33a are electrically isolated from one another by a shielding material. The electrical circuitry (not shown) of the mouthpiece 3 is operatively connected, in use, to the electrical circuitry (not shown) of the main body 2 such that a first series of the electrodes 32a delivers the first biphasic current and a second series of electrodes 33a delivers the second biphasic current.

[0067] In this embodiment, the mouthpiece 3 is provided as a separate component from the main body 2 and is configured such that it may be easily cleaned between sessions. However, in alternative embodiments, the mouthpiece 3 may be formed integrally with the main body 2. In yet further embodiments, the mouthpiece 3 may incorporate mounting means for mounting it to an upper and/or lower part of a user's mouth in a similar manner to a retainer. In such embodiments, the device 1 could include a pair of mouthpieces 3 each incorporating a mounting means, wherein a first mouthpiece 3 is adapted to be mounted to an upper part of the user's mouth and a second mouthpiece 3 is adapted to be mounted to a lower part of the

user's mouth. The first mouthpiece 3 could incorporate two series of electrodes 32a, 33a to contact the roof of the user's mouth and stimulate one or more palate muscles on one side and to contact the dorsal surface of the tongue and stimulate one or more tongue muscles on its other side. The second mouthpiece 3 could incorporate a single series of electrodes 32a to stimulate the sublingual muscles. The or each mouthpiece 3 may include the power source and, for example, a wireless communication means, such as a Bluetooth communication means, that communicates with the personal computer (not shown).

[0068] The charging station 4 has a cylindrical base 40 with a cylindrical projection 41 and an electrical cable 42 for connecting the charging station 4 to a source of mains electricity. The projection 41 in this embodiment incorporates an inductive coupling and the station 4 includes electrical circuitry connected to the electrical mains cable 42 for supplying electricity to the inductive coupling to inductively charge the batteries (not shown) in the main body 2.

[0069] Turning now to Figures 5 to 9, there is shown various tongue and palate muscles. Features of the mouth shown in Figures 5 to 7 illustrate more clearly the tongue muscles, wherein there is shown the pharyngopalatine arch 51, palatine tonsil 52, palatoglossus 53, buccinator 54, valate papillae 55, fungiform papillae 56, dorsal tongue surface 57, styloglossus 58, hyoglossus 59, mandible bone 60, genioglossus 61, longitudinal, transverse and vertical intrinsic muscles 62, 63, 64 and geniohyoid 65.

[0070] It is well established that the tone of the genioglossus muscle 61 most affects the collapsibility of the tongue as it is the biggest of the extrinsic muscle and responsible for pulling the tongue forward and increasing the airway opening in the throat. The tone of intrinsic surface muscles, such as the longitudinal and transverse intrinsic muscles 62, 63, also contribute to the reduction of the collapsibility of the airway.

[0071] Features of the mouth shown in Figures 8 and 9 illustrate more clearly the palate muscles, wherein there is shown the dental arch 66, premaxilla 67, incisive foramen 68, palatine process of maxilla 69, palatine bone 70, posterior nasal spine 71, palatine foramen 72, hamulus 73, tensor palatini muscle 74, levator veli palatini muscle 75, tensor veli palatini muscle 76, uvular muscle 77 and palatopharyngeus muscle 78.

[0072] To a varying degree, the constrictor and dilator muscles of the palate also contribute to snoring and sleep apnoea. The aim of the treatment is to dilate the throat, hence electrical stimulation is directed at the dilatory palate muscles in the midline, such as the uvular muscle 77, the levator veli palatini muscle 75 and the palatopharyngeus muscle 78.

[0073] In use, the mouthpiece 3 is applied to the dorsal tongue surface 57 and the aforementioned palate muscles and two biphasic currents are applied, each of which is configured with a first set of parameters including intensity, frequency and pulse duration. These biphasic currents are transmitted through the lining of the mouth, the oral mucosa, to stimulate the intrinsic surface muscles 62, 63, the uvular muscle 77, the levator veli palatini muscle 75 and the palatopharyngeus muscle 78. The parameters are selected to provide

maximal contraction of these muscles in the user and the treatment is carried out for a period of 20 minutes.

[0074] The intensity, frequency and pulse duration are then adjusted and the mouthpiece 3 is applied to the underside of the tongue. The two biphasic currents, now having a second set of parameters, are applied and transmitted trans mucosally to stimulate the genioglossus muscle 61. The second set of parameters are selected to provide maximal contraction of the user's genioglossus muscle 61 and the treatment is carried out for a period of 20 minutes.

[0075] The application of biphasic currents according to the parameters described above stimulate the aforementioned skeletal muscles. It is also believed that the application of this biphasic current to these skeletal muscles creates a further, sensory function, such as a vibratory sensation. Whilst not wishing to be bound by any theory, it is believed that this electrical and vibratory stimulation of the nerves provides feed back to the brain which further enhances the improvement in muscle tone. Specifically, it is believed that the effectiveness of this treatment is enhanced by multisensory integration within the nervous system.

[0076] By way of example, a treatment regime could involve a six week induction period during which each of the aforementioned muscle groups are stimulated for a period of 10 to 20 minutes, twice daily. The treatment regime, which is designed to build muscle tone, could then be followed by an ongoing maintenance regime involving 10 to 20 minute sessions once per day.

[0077] Referring now to Figures 10 and 11, there is shown a mouthpiece 103 according to a second embodiment similar to the first embodiment, wherein like references depict like features with a prefix 1. The mouthpiece 103 according to this embodiment includes a gripping base 130 and a pair of curved arms 131 formed integrally with one end of the base 130 to form a horseshoe shape. Each of the arms has first and second contact flanges 132, 133 within which is embedded electrodes (not shown).

[0078] The first contact flanges 132 extend inwardly toward one another from the free end of a respective one of the arms 131 and upwardly to form a curved shape for accommodating the dorsal tongue surface 57 of a tongue of a patient (not shown). The second contact flanges 133 extend inwardly toward one another from an intermediate part of a respective one of the arms 131 and downwardly to form a curved shape for accommodating the sublingual tongue surface.

[0079] The base 130 includes an enlarged end 134 joined to the arms 131 by a necked portion 135. The end surface of the enlarged end 134 includes an electrical connector 136 for connection with a source of power (not shown). The connector 136 may comprise a USB, microUSB or any other suitable type of wired connector. In other embodiments, the connector is replaced with a wireless connection means. In some embodiments, the mouthpiece incorporates a power source, such as a battery.

[0080] Similar to the first embodiment, the mouthpiece 103 also includes electrical circuitry (not shown) feeding a respective series of electrodes 132a, 133a at each surface of each flange 132, 133, that is to say each of the upper and lower surfaces of each of the flanges 132, 133. Each of these electrode series 132a, 133a is electrically isolated from the others by a shielding material, thereby enabling all surrounding muscles to be stimulated simultaneously or in any sequence required. The electrodes 132a, 133a cooperate with the outer surface of the flanges 132, 133 with which they are associated to form a substantially contiguous surface. In this embodiment, the mouthpiece 103 is formed of a silicon grade or a biocompatible grade plastic material. The electrodes 132a, 133a in this embodiment are preferably formed of gold or copper or composite material or any such alloy with an exposed surface.

[0081] In use, the mouthpiece 103 is placed in a patient's mouth and the tongue of the patient is received within the mouthpiece 103 such that the dorsal tongue surface 57 is in contact with the first contact flanges 132 and the sublingual tongue surface is in contact with the second contact flanges 133. It will be appreciated by those skilled in the art that the first flanges 132 will contact a rearward portion of the dorsal tongue surface 57 and the second flanges 133 will contact a frontward portion of the sublingual tongue surface. With the patient's mouth closed, the flanges 132, 133 are also able to contact and stimulate adjacent muscles on the other side of the tongue, for example the palate muscles. The muscles are stimulated in a similar manner to the device 1 according to the first embodiment, but this mouthpiece 103 enables the muscles to be stimulated on both sides of the tongue simultaneously. It will be appreciated that with this design, the muscles based in and around the tongue may be stimulated, including those in hard and soft palate areas.

[0082] It will be appreciated by those skilled in the art that several variations to the aforementioned embodiments are envisaged without departing from the scope of the invention. For example, the mouthpiece 3 may take any suitable form, but is preferably designed to enable the electrical stimulation to be applied to the appropriate muscles as described above. The dials 24, 25, 26, 27 may be replaced with other similar adjustment means or even omitted as explained above. The mouthpiece 3 and main body 2 may be provided as an integral unit and the charging station 4 may be omitted, for example the main body 2 may incorporate a mains cable 42 or simply require single use batteries or some other power source. Similarly, the USB port 28 may be omitted or replaced with some other connection means, which may be a wireless connection means. It will also be appreciated by those skilled in the art that any number of combinations of the aforementioned features and/or those shown in the appended drawings provide clear advantages over the prior art and are therefore within the scope of the invention described herein.

[0083] The invention is set out in the appended claims.

REFERENCES CITED IN THE DESCRIPTION

This list of references cited by the applicant is for the reader's convenience only. It does not form part of the European patent document. Even though great care has been taken in compiling the references, errors or omissions cannot be excluded and the EPO disclaims all liability in this regard.

Patent documents cited in the description

- US2014135868A1 [0008]
- US2007173893A1 [0008]
- JP2014158607A [0008]

PATENTKRAV

1. Transmukosal neuromuskulær elektrisk stimuleringsanordning (103), der omfatter et mundstykke (103), et elektrodemiddel (132a), der er forbundet med mundstykket (103), og et elektrisk kredsløb, der er operativt forbundet med elektrodemidlet (132a), kendetegnet ved, at
5 mundstykket (3; 103) omfatter et par arme (131), der er samlet med hinanden ved én ende og fjerner sig fra hinanden, med mindst én flange (132), der strækker sig indefter fra mindst én arm, hvor den mindst ene flange er formet til at samvirke med, tilnærmes eller rumme en dorsal tungeoverflade, den mindst ene flange (132) indbefatter elektrodemidlet (132a) forbundet dermed for tilvejebringelse, i anvendelse, via elektrodemidlet (132a) af elektrisk stimulering til
10 én eller flere gane- og/eller tungemusklervia den dorsale tungeoverflade (57) for at øge hvilemuskeltonus og/eller muskeltonus under søvn.
2. Anordning (103) ifølge krav 1, hvor den elektriske stimulering omfatter en tofaset elektrisk impulsstrøm med en frekvens på mellem 5 og 150 Hz.
15
3. Anordning (103) ifølge krav 2, hvor den tofasede elektriske impulsstrøm omfatter en amplitude på mellem 1 og 100 mA.
4. Anordning (103) ifølge et hvilket som helst foregående krav, der endvidere omfatter et
20 justeringsmiddel til justering af én eller flere af frekvens, amplitude, impulsvarighed og/eller behandlingsvarighed for en eller den tofasede elektriske impulsstrøm.
5. Device (103) ifølge et hvilket som helst foregående krav, der endvidere omfatter et styremiddel, der er programmeret eller kan programmeres til at styre én eller flere egenskaber
25 ved den elektriske stimulering eller den tofasede elektriske strøm ifølge en forudbestemt behandlingsplan.
6. Anordning (103) ifølge et hvilket som helst foregående krav, hvor elektrodemidlet (32a, 33a; 132a, 133a) omfatter en første række elektroder (32a; 132a) forbundet med en første side
30 af mundstykket og en anden række elektroder (33a; 133a) forbundet med en anden side deraf.
7. Anordning (103) ifølge krav 6, hvor den første række elektroder (32a; 132a) kan anvendes til at tilvejebringe en første elektrisk strøm og den anden række elektroder (33a; 133a) kan anvendes til at tilvejebringe en anden elektrisk strøm.

8. Anordning (103) ifølge et hvilket som helst foregående krav, der endvidere omfatter et greb (2; 134, 135, 136), hvortil mundstykket (3; 103) er monteret, for at gøre det muligt for mundstykket (3; 103) at blive indsat og/eller holdt, i anvendelse, inden for ét eller flere steder eller positioner og/eller orienteringer inde i munden.
9. Anordning (103) ifølge et hvilket som helst foregående krav, hvor mundstykket er uden monteringsmidler til fastgørelse heraf i en brugers mund.
10. Anordning (103) ifølge et hvilket som helst af krav 1 til 8, hvor mundstykket omfatter et monteringsmiddel til montering af mundstykket i munden.
11. Anordning (103) ifølge et hvilket som helst foregående krav, hvor parret af arme (131) er samlet ved én ende og fjerner sig fra hinanden for at tilvejebringe en i alt væsentligt hesteskoform.
12. Anordning (103) ifølge krav 11, hvor mundstykket (103) omfatter et første par flanger (132), der hver strækker sig indefter fra en tilsvarende arm, hvilke flanger er formet til at rumme en dorsal tungeoverflade (57).
13. Anordning (103) ifølge krav 11 eller 12, hvor mundstykket (103) omfatter et andet par flanger (133), der hver strækker sig indefter fra en tilsvarende arm (131), hvilke flanger (133) er formet til at rumme en sublingual tungeoverflade.
14. Anordning (103) ifølge krav 13, når det afhænger af krav 12, hvor hvert af det første par flanger (132) formet til at rumme en dorsal tungeoverflade (57) strækker sig fra ved eller stødende op til en fri ende af armen og hver af det andet par flanger formet til at rumme en sublingual tungeoverflade strækker sig fra en mellemliggende del af armen.
15. Anordning (103) ifølge krav 14, hvor det første par flanger (132) er forbundet med den første række elektroder (132a) og det andet par flanger (133) er forbundet med en anden række elektroder (133a).

DRAWINGS

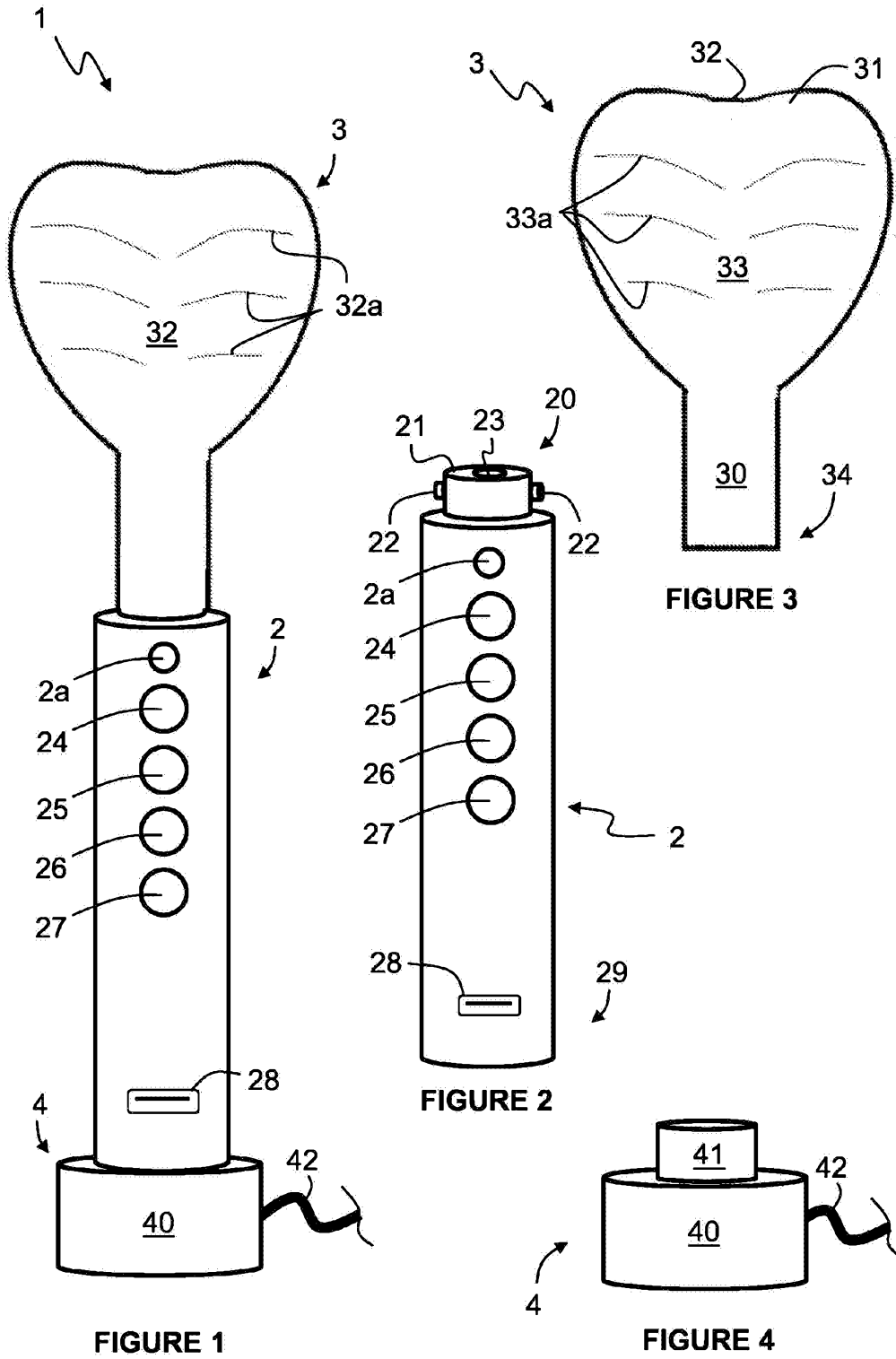

FIGURE 1

FIGURE 2

FIGURE 3

FIGURE 4

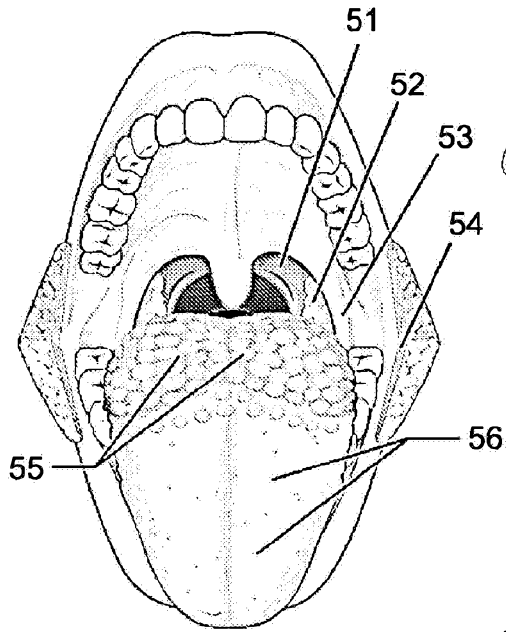

FIGURE 5

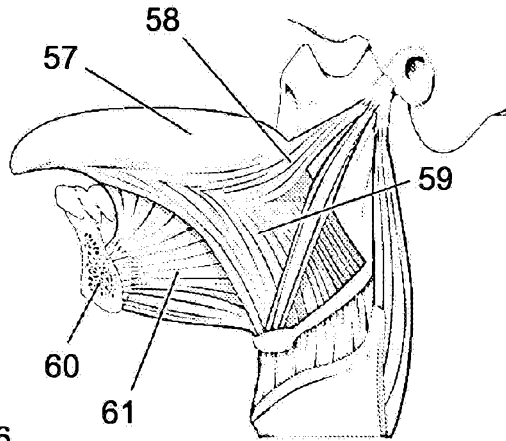

FIGURE 6

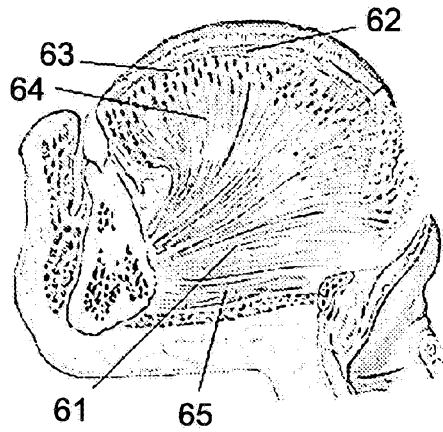

FIGURE 7

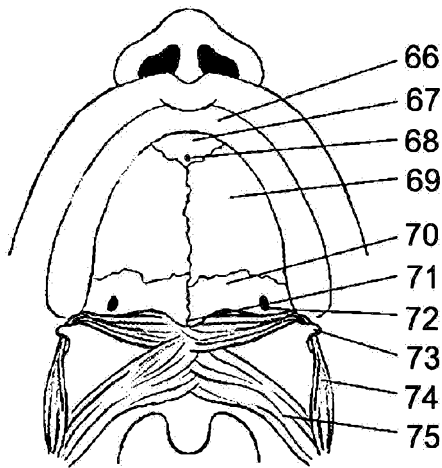

FIGURE 8

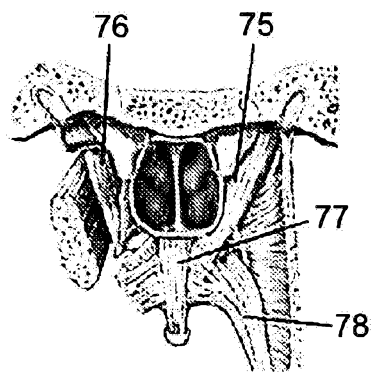

FIGURE 9

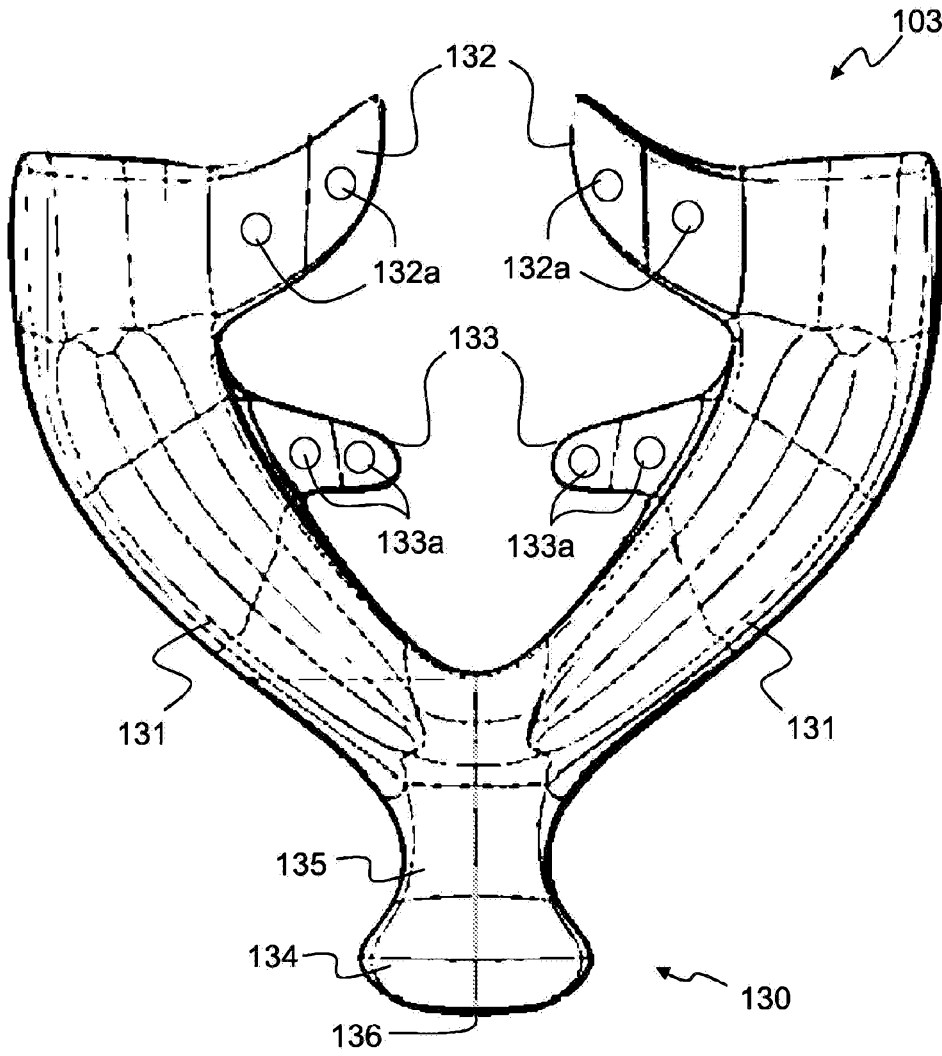

FIGURE 10

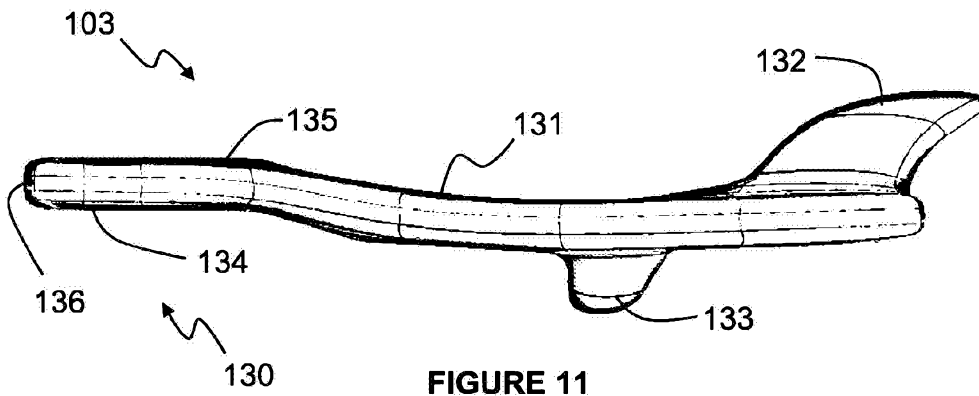

FIGURE 11