

(12) UK Patent Application (19) GB (11) 2508310 (13) A

(43) Date of Reproduction by UK Office 28.05.2014

(21) Application No: 1400969.0  
(22) Date of Filing: 21.06.2012  
Date Lodged: 21.01.2014  
(30) Priority Data:  
(31) 1110571.5 (32) 22.06.2011 (33) GB  
(86) International Application Data:  
PCT/GB2012/051444 En 21.06.2012  
(87) International Publication Data:  
WO2012/175974 En 27.12.2012

(51) INT CL:  
A47K 10/48 (2006.01) A61B 19/00 (2006.01)  
A61H 33/00 (2006.01) A61H 33/08 (2006.01)  
A61H 35/00 (2006.01)

(56) Documents Cited:  
WO87/00743A1  
US4219367A  
US3699984A  
US4295233A  
US3576277A

(58) Field of Search:  
INT CL A47K, A61B, A61H, E03C  
Other: EPO- INTERNAL, WPI DATA

(71) Applicant(s):  
Wallgate Ltd  
(Incorporated in the United Kingdom)  
Crow Lane, Wilton, Salisbury, Wiltshire, SP2 0HB,  
United Kingdom  
(72) Inventor(s):  
Andrew Boulton Renfrew  
Richard Denbury  
David Beale  
(74) Agent and/or Address for Service:  
Stevens Hewlett & Perkins  
1 Pemberton Row, LONDON, EC4A 3BG,  
United Kingdom

(54) Title of the Invention: Hand Cleaning apparatus  
Abstract Title: Hand Cleaning apparatus

(57) Hand cleaning apparatus is disclosed having a frame, fixing means for fixing the frame to a structure, a facia comprising a hand port for receiving the hands of a user, frame connecting means for connecting the facia to the frame, a chassis and chassis connecting means for connecting the chassis to the facia and/or the frame. Usually, the chassis will include a hand-sensor, an air blower and a connection to a controller, and optionally a soap dispenser and a water dispenser. The apparatus is modular which is of benefit in manufacture, use and maintenance.

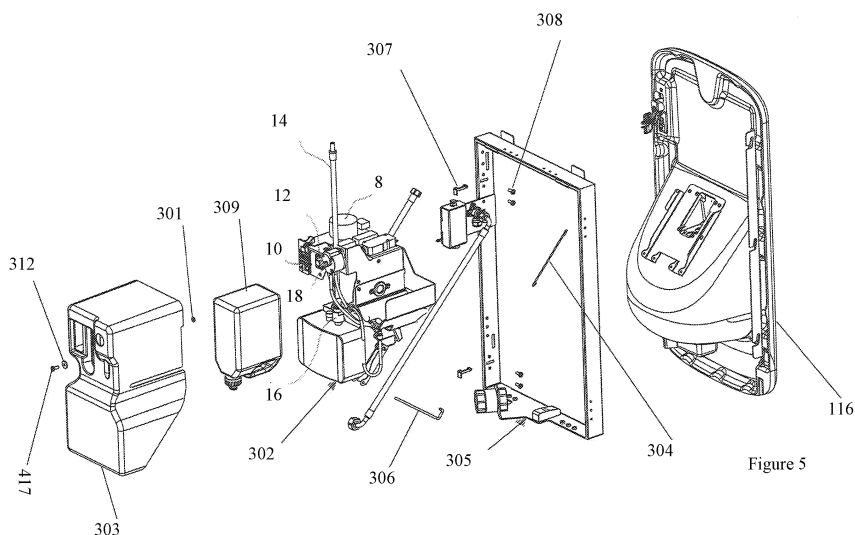

GB 2508310 A