

(12) UK Patent Application (19) GB (11) 2 174 830 A

(43) Application published 12 Nov 1986

(21) Application No 8609716

(22) Date of filing 21 Apr 1986

(30) Priority data

(31) 8510779 (32) 27 Apr 1985 (33) GB

(71) Applicant
David Clark,
96 Market Street, Stalybridge, Tameside

(72) Inventor
David Clark

(74) Agent and/or Address for Service
Barlow, Gillett & Percival, 94 Market Street,
Manchester M1 1PJ

(51) INT CL⁴
G08B 13/02

(52) Domestic classification (Edition H):
G4N 10 1X 2V 3F 5A FC
U1S 2188 G4N

(56) Documents cited
GB 1313058 GB 0302093
GB 1298803

(58) Field of search
G4N
G5J
B8P
Selected US specifications from IPC sub-classes G08B
G10K

(54) Tamper-proof enclosures

(57) A tamper-proof enclosure 10 for a burglar alarm bell 24 has four layers 14, 16, 18, 20 of material disposed inside an outer casing 12. Two layers 14, 18 are electrically conductive and connected to an electric circuit (not shown) such that when these two layers 14, 18 are in contact an alarm is operated. The other two layers 16, 20 are of a non-conductive insulating material. A framework 28 of metal spikes 30, 32, 34, 36, 38, 40, 42, 44 project from a base plate 26 and surrounds an alarm bell mechanism 24 of conventional design. If pressure is applied to the outer casing 12 the layers of material 14, 16, 18, 20 are punctured by one or more of the spikes, the electric circuit is completed and the alarm operated. If a heat source (not shown) or acid is used the insulating layers 16, 20 are destroyed and the circuit completed also operating the alarm.

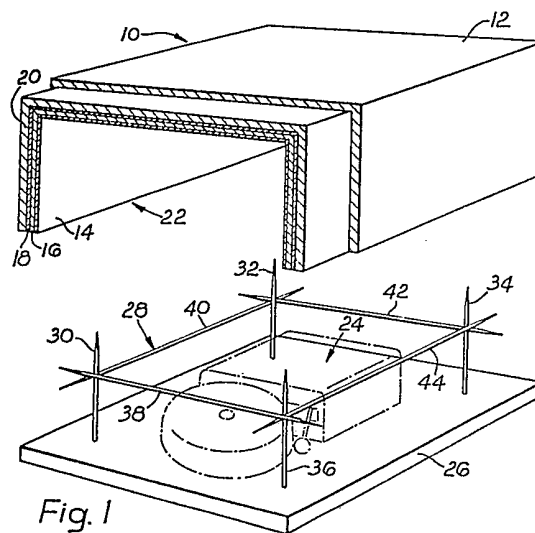

Fig. 1

GB 2 174 830 A

1/1

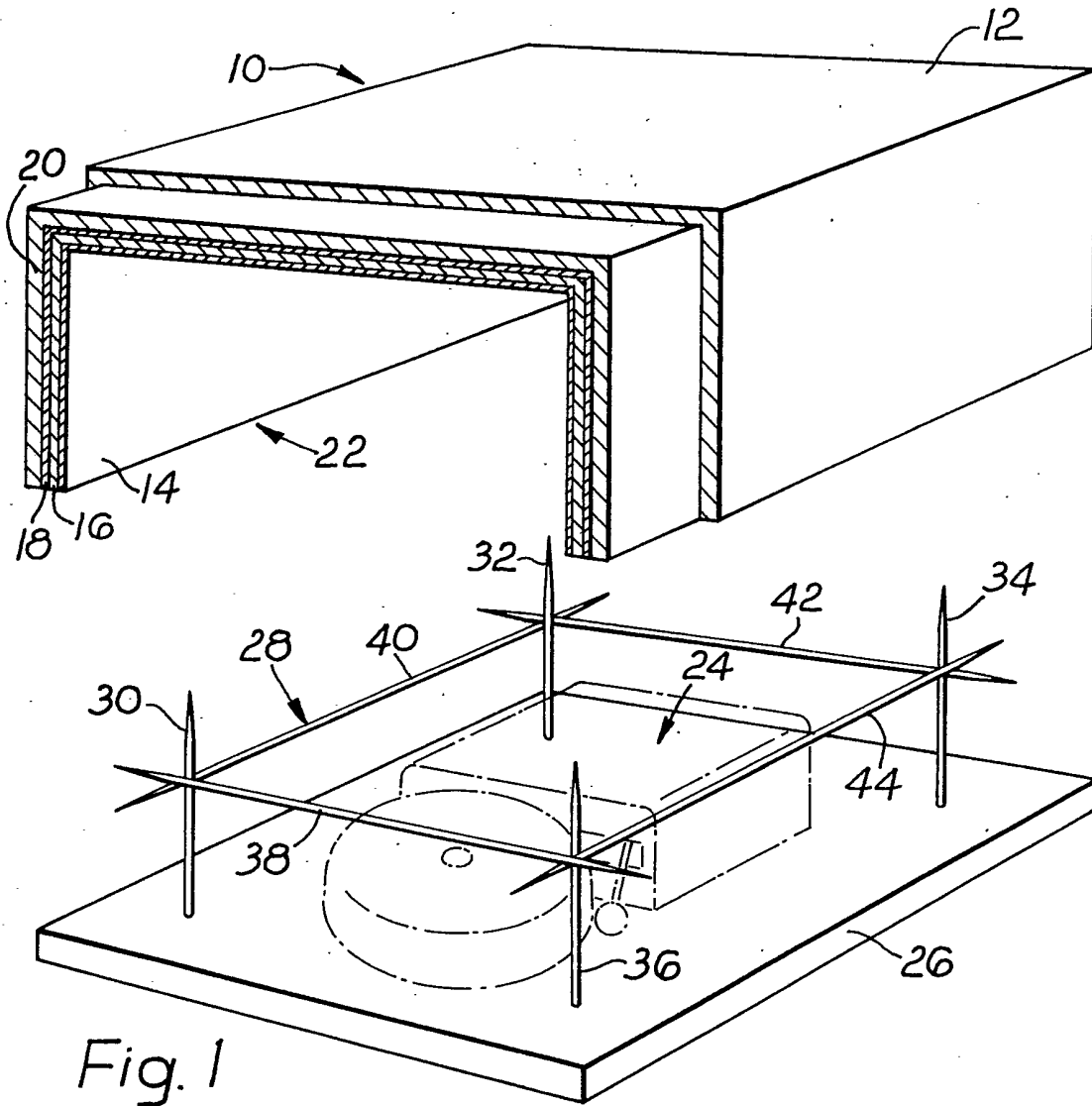

Fig. 1

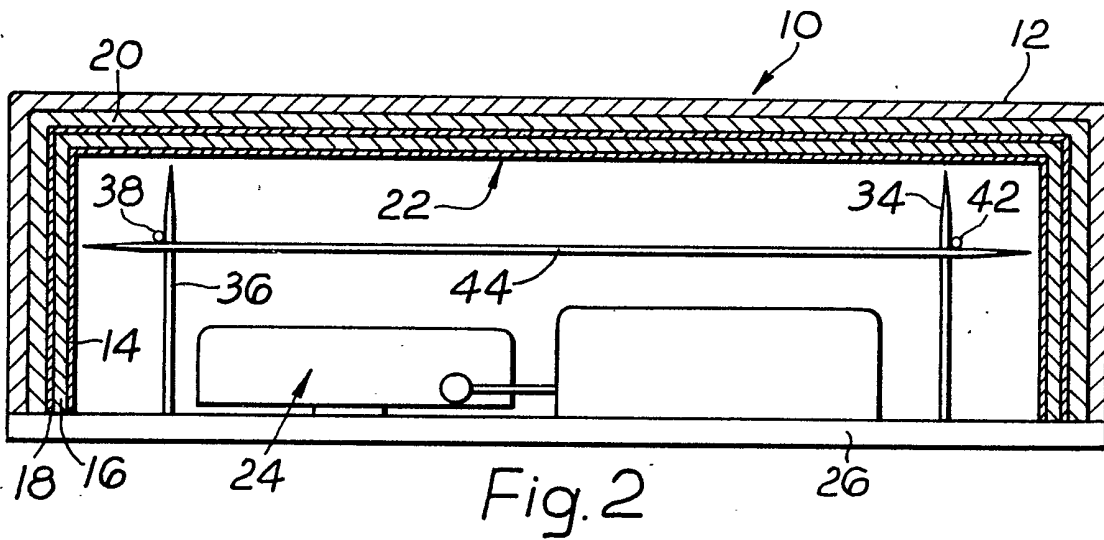

Fig. 2

SPECIFICATION

Tamper-proof enclosures

5 This invention concerns tamper-proof enclosures for burglar alarm bells.

It is common, on buildings fitted with burglar alarms, to have an alarm bell or siren which will ring or sound when the burglar alarm is set off.

10 The bell or siren is usually mounted on an exterior wall of the building in order that the ringing of the bell can be clearly heard by anyone in the vicinity of the building. However, anyone wishing to enter the building without setting off the alarm may try to prevent the alarm bell from ringing by tampering with the bell. The bell is usually mounted in a box and rigidly secured to a wall at a point which is an inaccessible as possible, usually high above ground level.

20 Even with the alarm bell or siren mounted in this position it is still possible to gain access to it by climbing up the wall using available hand or foot holds or by using a ladder or similar means. Furthermore if the building had only one storey high it would be difficult to site the alarm bell high enough to be out of a persons reach.

It is still possible to prevent the alarm bell from ringing even though it is protected by a box. For example the box can be struck by an object, e.g. a hammer, causing deformation of the box which will press against the bell thus preventing the bell from ringing. Alternatively the box can be moved and the bell disconnected from the circuit, or the box could be filled with cement or similar substances also with the object of preventing the bell from ringing.

An object of the present invention is to construct an enclosure for a burglar alarm bell which cannot be tampered with in any way without causing the alarm bell to ring.

Pursuant hereto the present invention provides a tamper-proof enclosure for a burglar alarm bell comprising an outer casing having therein an alarm bell and at least three layers of material, the first and third layers being electrically conductive and being part of an electric circuit, and the second layer, disposed between the first and the third layers, being electrically non-conductive, said layers being disposed so as to form an enclosure inside the outer casing containing the alarm bell.

If a hole is drilled through the outer shell or box by a metallic drill bit the bit will pierce the layers of material and complete the electric circuit thereby causing the alarm to go off.

Advantageously the layers of material are attached to a base plate on which is mounted the alarm bell, the base plate being provided with electrically conductive puncturing means which are disposed to puncture the layers of material if pressure is applied to the enclosure in the vicinity of said puncturing first and third electrically conductive layers being part of an electric circuit such that when the puncturing means pass through the material the electric circuit is completed and an alarm is operated. In this manner, force is applied to the

outer casing in order to deform it and thereby prevent the bell from ringing, the puncturing means are forced through the layered material completing the circuit and sounding the alarm.

70 Preferably a fourth, electrically non-conductive layer is provided disposed between the third layer and the outer casing. This additional layer will prevent accidental completion of the circuit if the outer shell is of metal or a similar electrically conductive material.

75 Advantageously the electrically non-conductive layer is of plastics material with a low melting point, for example, polythene. The use of a material with a low melting point means that any attempt to apply heat to the outer casing, for example a blow torch, will cause the non-conductive layer to melt and allow the two electrically conductive layers to contact and complete the circuit. This will also happen if acid is used to tamper with the alarm bell.

85 Preferably the puncturing means are a plurality of metal spikes projecting from the base plate such that any deformation of the enclosure will cause at least one of the spikes to puncture the enclosure and complete the circuit.

Advantageously the electric circuit to which the conductive layers are connected is that provided to operate the alarm bell normally.

The invention will be described further, by way of example, with reference to the accompanying drawings, in which:-

90 *Figure 1* is a part sectional exploded perspective view of a preferred embodiment of the tamper-proof enclosure of the invention; and

100 *Figure 2* is a part sectional end view generally similar to *Figure 1* illustrating the tamper-proof enclosure assembled.

A preferred embodiment of the tamper-proof enclosure for a burglar alarm bell referred to generally by the reference numeral 10 comprises an outer shell or box 12 inside which four layers of material 14, 16, 18, 20 are disposed. Two of the layers of material 14, 18 are electrically conductive and two of the layers 16, 20 are electrically non-conductive, i.e. insulating. The electrically conductive layers 14, 18 are of metal, preferably thin aluminium foil, and the insulating layers 16, 20 are of plastics material, preferably thin polythene sheeting. The layers 14, 16, 18, 20 are arranged alternatively so that the electrically conductive layers 14, 18 are separated by one of the insulating layers 16 and the second insulating layer 20 is adjacent to one of the conductive layers 18. The layers of material 14, 16, 18, 20 are shaped to produce an enclosure 22 which encloses on five sides, a burglar alarm bell mechanism 24 of conventional design which is attached to a base plate 26. It is usual to have 4, 6, or 8 cables (not shown) passing through the base plate to the bell 24, however, commonly only two of these are connected to the burglar alarm circuit (also not shown). The conductive layers 14, 18 are attached one to each of the two live cables (not shown) so that the enclosure 22 is part of the burglar alarm circuit and the completion of this circuit will cause the alarm bell 24 to ring. A

framework 28 of four upstanding metal spikes 30, 32, 34, 36 is attached to the base plate, end metal spike 30, 32, 34, 36 equidistant from a respective corner of the base plate 26. Four further metal spikes 38, 40, 42, 44 are attached to the upstanding spikes 30, 32, 34, 36 disposed substantially parallel to the base plate 26 so that the spikes 30, 32, 34, 36, 38, 40, 42, 44 surround the bell 24 and the enclosure 22 is in contact with the spikes. The outer shell or box 12 is fitted around the base plate 26 and the alarm bell 24 thereby fitting over the tamper-proof enclosure 22. The spikes 30, 32, 34, 36, 38, 40, 42, 44 do not press against the enclosure 22 when the box 12 is fitted so as to allow for possible expansion or contraction if the box 12 is of metal or a similar material.

When the burglar alarm circuit (not shown) is activated the enclosure 22 is operative to prevent tampering with the alarm bell mechanism 24. If the box 12 surrounding the bell mechanism 24 is struck, in order to deform the box 12 and prevent the bell mechanism from operating, then the enclosure 22 is brought into contact with the spikes 30, 32, 34, 36, 38, 40, 42, 44 which push through the enclosure 22 completing the circuit connected to the conductive layers 14, 18 and hence sounding the alarm 24. If a heat source, for example a cutting torch, is applied to the box 12 and hence the enclosure 22 the insulating layers 16, 20 will melt allowing the conducting layers 14, 18 to contact and set the alarm 24 off. A drill passing through the enclosure 22 will complete the circuit via the drill bit itself and the use of acid will result in the insulating layers 16, 20 dissolving first and the alarm operating in a similar manner to that when a heat source is used.

The second insulating layer 20 is not essential to the normal operation of the invention. It will be understood from the foregoing description that the enclosure 22 would function with only one insulating layer 16 present. This second insulating layer 20 is provided to prevent accidental contact between the outermost conducting layer 18 and the outer shell or box 12. Such contact could complete the alarm circuit by way of the base plate 26 where both the box 12 and the base plate 26 are of metal and hence electrically conductive.

The invention is not confined to the precise details of the foregoing and variations may be made thereto. Thus, for example, the spikes could be replaced by metal blades or other similar means for puncturing the enclosure. Furthermore, the conductive layers could be attached to a separate alarm circuit and they need not be attached to the same circuit as the bell they are protecting.

Alternatively a second alarm bell mechanism could be attached to the base plate within the enclosure. This second alarm bell mechanism would be attached to the circuit including the two conducting layers in the enclosure and would therefore ring if the enclosure was tampered with. The outer insulating layer could be omitted without impairing the normal operation of the enclosure. The outer shell need not be of metal. The spikes provided need not be disposed in the manner previ-

ously described and their number may be greater or smaller than that indicated in the preferred embodiment. Other variations may also be possible.

70 CLAIMS

1. A tamper-proof enclosure for a burglar alarm bell comprising an outer casing having therein an alarm bell and at least three layers of material, the first and third layers being electrically conductive and being part of an electric circuit, and the second layer, disposed between the first and the third layers, being electrically non-conductive, said layers being disposed so as to form an enclosure inside the outer casing containing the alarm bell.

2. A tamper-proof enclosure as claimed in claim 1 wherein the layers of material are attached to a base plate on which is mounted the alarm bell, the base plate being provided with electrically conductive puncturing means which are disposed to puncture the layers of material if pressure is applied to the enclosure in the vicinity of said puncturing means, first and third electrically conductive layers being part of an electric circuit such that when the puncturing means pass through the material the electric circuit is completed and an alarm is operated.

3. A tamper-proof enclosure as claimed in claim 1 or 2 wherein a fourth layer electrically non-conductive, is provided disposed between the outer casing and an electrically conductive layer of the enclosure.

4. A tamper-proof enclosure as claimed in claim 1, 2 or 3 wherein the electrically non-conductive layer is of plastics having a low melting point.

5. A tamper-proof enclosure as claimed in claim 2 wherein the puncturing means are a plurality of metal spikes projecting from the base plate such that any deformation of the enclosure will cause at least one of the spikes to puncture the enclosure and complete the circuit with the two electrically conductive layers.

6. A tamper-proof enclosure as claimed in any preceding claim wherein the alarm operated by the electric circuit containing the two electrically conductive layers of the enclosure is an alarm bell disposed inside the enclosure.

7. A tamper-proof enclosure for a burglar alarm bell substantially as hereinbefore described with reference to and as illustrated in the accompanying drawings.