



INTERNATIONAL APPLICATION PUBLISHED UNDER THE PATENT COOPERATION TREATY (PCT)

<p>(51) International Patent Classification ⁵ : B65D 5/70</p>	<p>A1</p>	<p>(11) International Publication Number: WO 95/09109 (43) International Publication Date: 6 April 1995 (06.04.95)</p>
<p>(21) International Application Number: PCT/US94/09079 (22) International Filing Date: 11 August 1994 (11.08.94) (30) Priority Data: 08/128,945 29 September 1993 (29.09.93) US (71) Applicant: RIVERWOOD INTERNATIONAL CORPORATION [US/US]; Suite 1600, 3350 Cumberland Circle, Atlanta, GA 30339 (US). (72) Inventor: FOGLE, James, C.; 4239 Cove Way, Marietta, GA 30067 (US). (74) Agent: McLARY, Steve, M.; Riverwood International Corporation, Suite 1600, 3350 Cumberland Circle, Atlanta, GA 30339 (US).</p>		<p>(81) Designated States: AU, BR, CA, FI, JP, KR, NO, NZ, European patent (AT, BE, CH, DE, DK, ES, FR, GB, GR, IE, IT, LU, MC, NL, PT, SE). Published <i>With international search report.</i></p>

(54) Title: CORNER WITH RECLOSABLE CORNER POUR OPENING

(57) Abstract

A carton constructed to permit the contents to be poured out over an upper corner. The top panel (18) includes a fold line (46) about which a corner closure flap (47) pivots. The corner flap includes a flange (45) formed by tear lines in portions of the adjacent side and end panels (12, 14). Additional layers of material in face-to-face contact with the inner surface of the side and end panels in the area of the closure flap provide edges over which the contents are poured. The closure flap fits tightly over the additional layers to hold it in place after it has been reclosed.

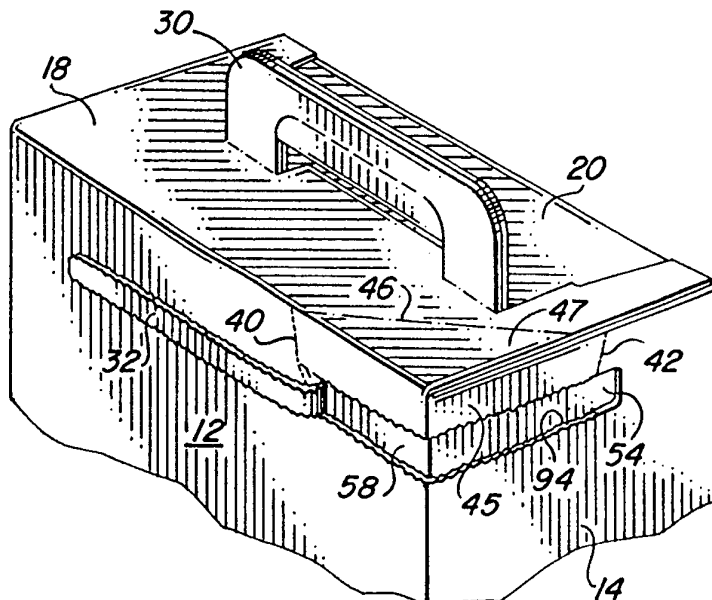

FOR THE PURPOSES OF INFORMATION ONLY

Codes used to identify States party to the PCT on the front pages of pamphlets publishing international applications under the PCT.

AT	Austria	GB	United Kingdom	MR	Mauritania
AU	Australia	GE	Georgia	MW	Malawi
BB	Barbados	GN	Guinea	NE	Niger
BE	Belgium	GR	Greece	NL	Netherlands
BF	Burkina Faso	HU	Hungary	NO	Norway
BG	Bulgaria	IE	Ireland	NZ	New Zealand
BJ	Benin	IT	Italy	PL	Poland
BR	Brazil	JP	Japan	PT	Portugal
BY	Belarus	KE	Kenya	RO	Romania
CA	Canada	KG	Kyrgystan	RU	Russian Federation
CF	Central African Republic	KP	Democratic People's Republic of Korea	SD	Sudan
CG	Congo	KR	Republic of Korea	SE	Sweden
CH	Switzerland	KZ	Kazakhstan	SI	Slovenia
CI	Côte d'Ivoire	LI	Liechtenstein	SK	Slovakia
CM	Cameroon	LK	Sri Lanka	SN	Senegal
CN	China	LU	Luxembourg	TD	Chad
CS	Czechoslovakia	LV	Latvia	TG	Togo
CZ	Czech Republic	MC	Monaco	TJ	Tajikistan
DE	Germany	MD	Republic of Moldova	TT	Trinidad and Tobago
DK	Denmark	MG	Madagascar	UA	Ukraine
ES	Spain	ML	Mali	US	United States of America
FI	Finland	MN	Mongolia	UZ	Uzbekistan
FR	France			VN	Viet Nam
GA	Gabon				

CORNER WITH RECLOSABLE CORNER POUR OPENING
Field of the Invention

This invention relates to cartons for packaging pourable material. More particularly, it relates to
5 cartons of this type which contain closable pouring openings.

Background of the Invention

It is well known to package dry particulate material in boxes or cartons from which it can be poured. Cereal,
10 for example, is conventionally packaged in rectangular boxes having a top panel formed from overlapping flaps connected to the side panels and underlying glue flaps connected to the end panels. The package is opened by separating the outer top panel flap from the inner top
15 panel flap, and is closed by inserting an end tab on the outer flap into a locking slot in the inner flap. The slot is initially hidden from view by the overlapping flap and is exposed upon separating the two flaps. A common complaint against this package design is the difficulty in
20 separating the flaps. The glue adhering the overlapping flaps to each other and to the underlying short glue flaps is often so strong or so liberally applied that the outer flap tears instead of separating along the glue line. If the tab is completely torn off, the top panel flaps cannot
25 be connected together to close the package. Even if the tab is only partially torn or the outer flap is weakened by tearing in other areas, the flaps cannot normally be securely held in place after opening.

Another complaint against the conventional package has
30 to do with pouring the contents. Pouring takes place over an end edge of the top opening and over the adjacent opened end glue flap. This relatively wide area makes it difficult to control the flow of the particles, sometimes resulting in the particles spilling out over the outer
35 sides of the glue flaps.

When packaging heavier particulate material the carton can be too heavy to conveniently be lifted by grasping the sides of the carton. It would be preferable in these cases to carry the package by a handle instead. Moreover, if it

-2-

is desired to have a wider carton for better stability and handleability or to more conveniently package greater quantities of material in a carton, a handle becomes necessary. Introduction of a handle, however, limits the ability to provide a pouring opening in the top panel.

It would be desirable to have a carton with an improved reclosable pouring arrangement capable of concentrating the flow of particles poured from the carton.

Brief Summary of the Invention

The invention is embodied in a carton comprised of side panels, end panels, a top panel and a bottom panel. A closure flap movable from closed position to open position is provided in a corner portion of the top panel and includes a flange comprised of upper portions of adjacent side and end panels. The carton further includes corner edges over which material packaged in the carton can be poured after the closure flap has been opened and means for maintaining the closure flap in closed position until disabled.

In a preferred embodiment, the means for maintaining the closure flap in closed position until disabled comprises tear lines connecting the closure flap flange to portions of the adjacent side and end panels. Removal of a tear strip in the side and end panels directly beneath the flange provides access to the flange when initially opening the closure flap. Fold lines in the top panel permit the closure flap to pivot up when moved from closed to open position.

The corner pouring edges are the upper edges of inserts or flaps positioned directly inside the portions of the side and end panels forming the flange of the closure flap. A handle in the top panel facilitates lifting and tilting the carton for pouring.

The carton can be readily opened without destroying or damaging its pouring and reclosing features and can be economically formed from a blank of generally rectangular shape.

These and other features and aspects of the invention,

as well as its various benefits, will be made more clear in the subsequent detailed description of the preferred embodiment.

Brief Description of the Drawings

5 FIG. 1 is a pictorial view of a carton embodying the features of the invention;

FIG. 2 is a plan view of a blank for forming the carton of FIG. 1;

10 FIG. 3 is a partial pictorial view of the carton at an interim stage of fabrication;

FIG. 4 is a transverse sectional view taken along line 4-4 of FIG. 3;

FIG. 5 is a partial pictorial view of the carton at a subsequent interim stage of fabrication;

15 FIG. 6 is a partial pictorial view of the carton during removal of the tear strip;

FIG. 7 is a partial pictorial view of the carton similar to that of FIG. 6, but after the corner closure flap has been folded up for pouring; and

20 FIG. 8 is a partial plan view of a carton blank with a modified top panel flap design.

Detailed Description of the Preferred Embodiments

Referring to FIG. 1, the carton 10 is comprised of side panels 12 connected to end panels 14, a top panel 16
25 and a bottom panel, not visible in this view. Overlapping flaps 18 and 20, which are connected to their associated side panels by fold lines 22 and 24, form the top panel, and aligned handle sections 26 and 28, which extend up from the top panel flaps 18 and 20, form a handle 30. A tear
30 strip 32, defined along its major length by spaced parallel tear lines 34 and 36, extends from a point in the side panel 12 to a point in the end panel 14, bridging the fold line or corner 38 between the adjacent panels. Tear line 40 in side panel 12 extends up from the end of the tear
35 strip 32 to the fold line 22, and in like manner tear line 42 in end panel 14 extends up from the tear strip to the fold line 44. A diagonal score line 46 in the top panel flap 18 extends from a point adjacent the end of the tear

-4-

line 40 to a point adjacent the end of the tear line 42. The area between the tear lines 34, 40 and 42 and the top panel comprises a right-angled flange 45, and the portion of the top panel between the flange 45 and the score line
5 46 comprises a closure flap 47. The function of the tear lines, score line, flange and closure flap will be made clear below.

A blank for forming the carton is shown in FIG. 2, wherein like reference numerals to those used in FIG. 1
10 refer to similar elements. The blank 48 is substantially rectangular in shape and comprised of a suitably strong, flexible material such as paperboard of the type conventionally employed in the carton and carrier industry. The end panel section 14 containing the tear strip is at
15 the end of the blank and the side panel section 12 containing the tear strip is adjacent to it, connected by the fold line 38. The other end panel section 14 is connected along fold line 50 to the same side panel section 12 and along fold line 52 to the other side panel section
20 12. A first insert flap 54 is connected to the latter side panel section 12 along fold line 56 and to a second insert flap 58 along fold line 60. The function of the insert flaps will be explained in more detail below.

Bottom panel flaps 62 are connected to the side panel
25 sections 12 by fold lines 64, and bottom panel glue flaps 66 are connected to the end panel sections 14 and 54 along fold lines 68. A top panel glue flap 70 is connected to the end panel section 14 containing the tear strip by the fold line 44, and another top panel glue flap 72 is
30 connected to the other end panel section 14 by fold line 74. As also shown in FIG. 1, the top panel flaps 18 and 22 are connected to the side panel sections 12 along fold lines 22 and 24, respectively. The handle sections 26 and 28 are connected to their top panel flaps 18 and 20 by fold
35 lines 76, and are separated from the top panel flaps by slits 78. Handle tabs or flaps 80 and 82 are connected to the handle sections 26 and 28 along fold lines 84 and 86, and are separated from the top panel flaps by slits 88.

In addition, top panel glue flap 70 includes a fold line 90 extending from a point adjacent the end of tear line 42 to a point adjacent the end of score line 46, and top panel flap 20 includes a fold line 92 extending diagonally from a point adjacent the handle section 28 to a point at the end edge of the blank intermediate the width of the top panel flap 20.

To form a carton from the blank 48, assuming that the side of the blank facing the viewer is the interior surface of the blank, the blank is folded in about fold lines 52 and 38, causing the insert flap 54 to overlie the remote end panel section 14 and the insert flap 58 to overlie a portion of the adjacent side panel section 12. The insert flaps 54 and 58 are adhered to the end panel section 14 and the side panel section 12, respectively, in the stippled areas of the latter panel sections. Note that the insert flaps are not adhered to the tear strip 32 or to the flange 45. It will be understood that although the glue has been shown as being applied to the end and side panel sections, it can instead be applied to the insert flaps 54 and 58 in a similar pattern so as to contact the blank in areas corresponding to the stippled portions.

The folding and gluing steps result in formation of a collapsed sleeve. The sleeve is then squared up and the bottom panel is formed in conventional manner by folding the bottom glue flaps 66 in, folding and adhering one of the bottom panel flaps 62 to the glue flaps and folding and adhering the other bottom panel flap to the first bottom panel flap. The resulting open-top carton is illustrated in FIG. 3, which shows the top panel flaps 18 and 20 and the top panel glue flaps 70 and 72 extending upwardly as substantial extensions of the side and end panels of the carton. The carton is filled with the flaps in the position shown or folded back even farther so as not to interfere with the filling process. As illustrated in FIG. 4, the insert flap 58 is in face-to-face contact with an end portion of the side panel 12 and the insert flap 54 is in similar contact with the adjacent end panel 14.

After the carton has been filled the glue flaps 70 and 72 are folded down into horizontal position, glue is applied to the top panel flap 20 and the top panel flap is folded down and adhered to the glue flaps. Glue is also applied to the top panel flap 18, after which it is folded down and adhered to the glue flaps and to the underlying portions of the top panel flap 20. During these maneuvers edge 88 of the central portion of the top panel flap 20 moves under the edge 88 of the top panel flap 18 and the end portions of the top panel flap 18 overlie the end portions of the top panel flap 20. The handle sections 26 and 28 are folded to their upright position and brought together to form the two-ply handle shown in FIG. 1. As can be seen from FIGS. 3 and 5, the fold line 90 of the top panel glue flap 70, the fold line 92 of the top panel flap 20 and the score line 46 of the top panel flap 18 are in substantial alignment.

To open the carton the tear strip 40 is removed, as illustrated in FIG. 6, to create the opening 94 in the end panel 14 and side panel 12. The tear strip may be designed to be readily grasped, as by providing the end with a break-away tip, or by any other conventional expedient. Removal of the tear strip is readily accomplished since it will be recalled that the tear strip itself is not glued to the underlying insert flaps 54 and 58. The opening process is completed by pivoting the closure flap 47 up about the aligned fold lines 90, 92 and 46, to the position shown in FIG. 7. This can be most conveniently accomplished by pushing up against the corner of the flange 45 with enough force to sever the short tear lines 40 and 42. This is a simple step since, like the tear strip 32, the flange 45 is not adhered to the insert flaps 54 and 58. The closure flap 47 thus consists of the corner portion of the top panel flap 18, the underlying outer portion of the top panel flap 20 and the underlying corner portion of the top panel glue flap 70. The carton can now be tilted and the contents poured out over the corner formed by the adjoining insert flaps 54 and 58, which thus functions as

a pouring spout. Lifting and tilting of the carton is made easy by the upstanding handle.

Although a particular type of top panel configuration and associated handle arrangement has been shown for purpose of illustration, it should be understood that the invention is not limited to such structure. For example, as shown in FIG. 8, the top panel flaps 18' and 20' may be of simpler design, not broken up by inclusion of a handle section but consisting simply of full panel sections containing central handle cutouts 96 and 98. When forming the top panel of a carton of this type, the two top panel flaps overlap, as in the formation of the bottom panel. The handle cutouts are aligned, permitting a separate handle strap to be adhered to the underlying top panel flap so as to extend up through the cutouts. In such an arrangement, the fold line 92' in the top panel flap 20' is of full length, since the top panel flap is not broken up by a handle section, and underlies the full length of the fold line 90 in a carton formed from the blank.

Regardless of the top panel and handle design, the corner opening and spout arrangement remain the same, with tear strips in the side and end panels and fold lines in the top panel allowing a corner portion of the top panel to be folded up to provide an opening through which the contents of the carton can be poured. Provision of the insert flaps provides a corner pouring edge which guides and controls the flow of the contents in a manner superior to the pouring edge of cartons in which the entire upper edge of one of the end panels functions as the pouring edge.

To reclose the lid or closure flap, it merely has to be pushed down again to its original position. Since the insert flaps maintain the integrity of the corner formation of the carton, the original tight fit of the closure flap flange 45 is again obtained, which tightly maintains the flap in closed position.

The carton is economical to produce, being formed from a single blank of generally rectangular shape by means of

a few simple folding and gluing steps which can be carried out by hand or in a packaging machine. It can be carried easily by the upstanding handle, and can be stored or shipped in stacked layers made possible by the ability of
5 the handle to be moved out of the way, as by being folded down or depressed into its recess, depending on the particular top panel and handle design employed. Further, the ability to reclose the carton to a secure, tight condition is very beneficial.

10 It should be apparent that the invention is not necessarily limited to all the specific details described in connection with the preferred embodiments, but that changes to certain features of the preferred embodiments
15 of the invention may be made without departing from the spirit and scope of the invention defined in the appended claims.

WHAT IS CLAIMED IS:

- 1 1. A carton for packaging pourable material,
2 comprising:
3 side panels connected to end panels, a top panel and
4 a bottom panel;
5 a closure flap in a corner portion of the top panel
6 movable from closed position to open position;
7 the closure flap including a flange comprised of upper
8 portions of adjacent side and end panels;
9 the carton including corner edges over which material
10 packaged in the carton can be poured after the closure flap
11 has been moved from closed to open position; and
12 means for maintaining the closure flap in closed
13 position until disabled.
- 1 2. A carton as defined in claim 1, wherein the means
2 for maintaining the closure flap in closed position until
3 disabled comprises tear lines connecting the flange to
4 portions of the adjacent side and end panels.
- 1 3. A carton as defined in claim 2, including a tear
2 strip in the side and end panels beneath the flange, the
3 tear strip having an upper edge coinciding with the lower
4 edge of the flange.
- 1 4. A carton as defined in claim 1, wherein the top
2 panel includes a fold line about which the closure flap
3 pivots when moving from closed to open position.
- 1 5. A carton as defined in claim 4, wherein the fold
2 line extends diagonally across the corner portion of the
3 top panel between adjacent side and end panels.
- 1 6. A carton as defined in claim 4, wherein the
2 closure flap is comprised of portions of overlapping top
3 panel flaps and an underlying glue flap, the closure flap
4 fold line being comprised of substantially aligned fold
5 lines in each of the overlapping top panel flaps and the
6 underlying glue flap.
- 1 7. A carton as defined in claim 1, wherein said
2 corner edges are comprised of upper edges of inner layers
3 in face-to-face relationship with the portions of the side
4 and end panels forming the flange of the closure flap, said

5 inner layers being nonadhered to said portions of the side
6 and end panels.

1 8. A carton as defined in claim 7, wherein the inner
2 layers are extensions of the side panel opposite the side
3 panel in which a portion of the flange is located.

1 9. A carton as defined in claim 7, wherein the flange
2 fits tightly over said inner layers when reclosed after
3 being opened.

1 10. A carton as defined in claim 1, including a
2 handle extending up from the top panel.

1 11. A carton for packaging pourable material,
2 comprising:

3 side panels connected to end panels, a top panel and
4 a bottom panel;

5 a closure flap in a corner portion of the top panel,
6 the closure flap being connected to the top panel by a fold
7 line about which the closure flap pivots when moved from
8 closed to open position;

9 the closure flap including a flange comprised of upper
10 portions of adjacent side and end panels;

11 the carton including corner edges over which material
12 packaged in the carton can be poured after the closure flap
13 has been moved from closed to open position; and

14 tear lines connecting the flange to portions of the
15 adjacent side and end panels, the tear lines maintaining
16 the closure flap in closed position until severed.

1 12. A carton as defined in claim 11, wherein said
2 corner edges are comprised of upper edges of inner layers
3 in face-to-face relationship with portions of the side and
4 end panels forming the flange of the closure flap, said
5 inner layers being nonadhered to said portions of the side
6 and end panels but being adhered to lower portions of the
7 side and end panels.

1 13. A carton as defined in claim 11, including a tear
2 strip in the side and end panels beneath the flange, the
3 tear strip having an upper edge coinciding with the lower
4 edge of the flange.

1 14. A blank for forming a carton for packaging

-11-

2 pourable material, comprising:

3 alternating side and end panel sections connected by
4 fold lines;

5 bottom panel flaps connected to the side and end panel
6 sections along fold lines;

7 top panel flaps connected to the side and end panel
8 sections along fold lines, the top panel flaps adapted to
9 be overlapped to form the top panel of the carton;

10 tear lines in adjacent side and end panel sections
11 forming a flange extending from the fold lines connecting
12 the side and end panel sections to the top panel flaps;

13 fold lines in the top panel flaps adapted to be
14 substantially aligned in the carton and to extend from one
15 end of the flange to the other so as to form a closure flap
16 in a corner portion of the top panel of the carton; and

17 the blank including edges over which material packaged
18 in the carton can be poured after the closure flap has been
19 moved from closed to open position.

1 15. A carton blank as defined in claim 14, including
2 a tear strip in said adjacent side and end panel sections
3 beneath the flange, the tear strip having an edge
4 coinciding with a lower edge of the flange.

1 16. A carton blank as defined in claim 14, wherein
2 the end panel section containing the tear lines is at one
3 end of the blank and the pouring edges are comprised of
4 edges of an insert section connected to the opposite end
5 of the blank.

1 17. A carton blank as defined in claim 16, wherein
2 the insert section is comprised of a first flap connected
3 to the blank along a fold line and a second flap connected
4 to the first flap along a fold line, the first flap being
5 adapted to be adjacent the end panel section containing the
6 tear lines in a carton formed from the blank and the second
7 flap being adapted to be adjacent at least a portion of the
8 side panel section containing the tear lines.

1 18. A carton blank as defined in claim 14, including
2 handle means in the top panel flaps connected to the side
3 panel sections.

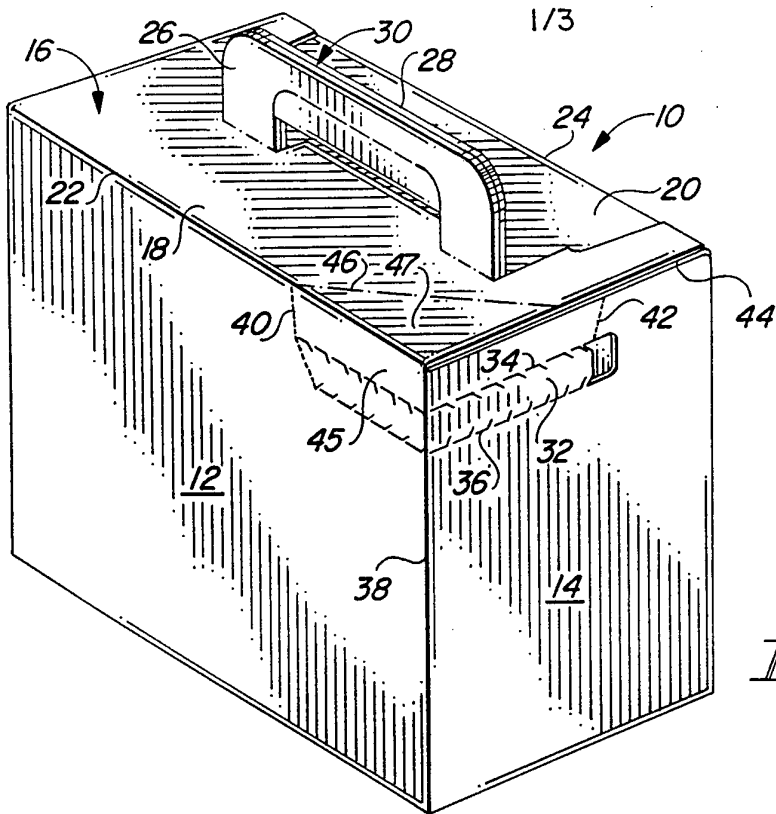

FIG. 1

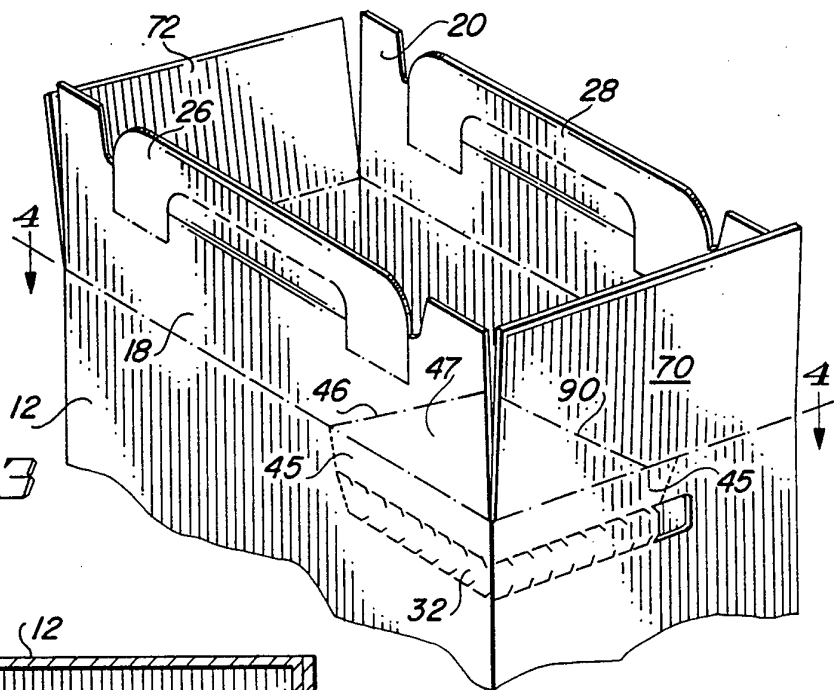

FIG. 3

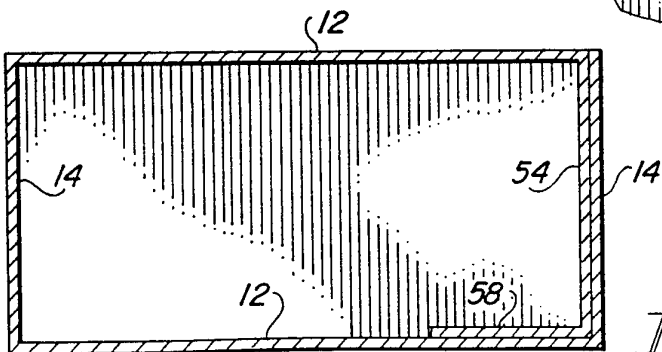

FIG. 4

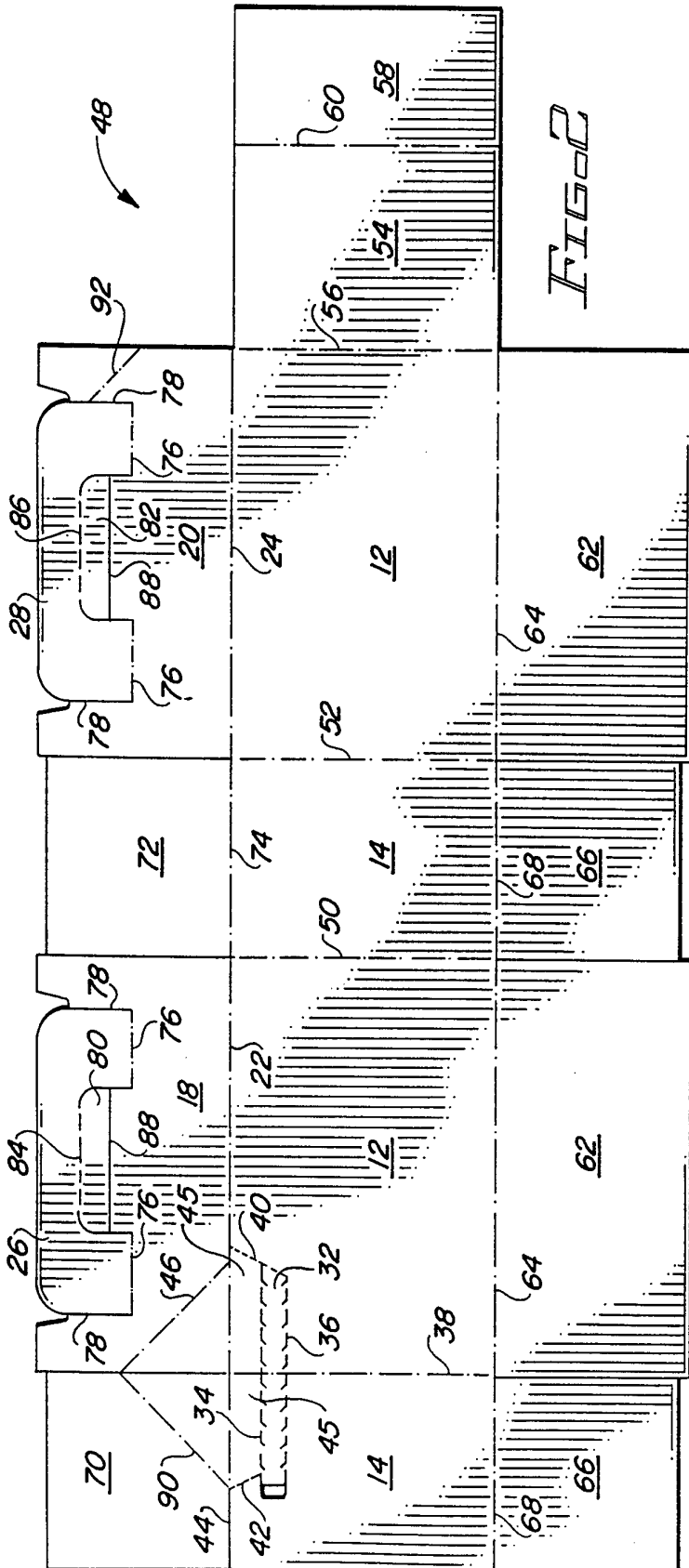

FIG. 2

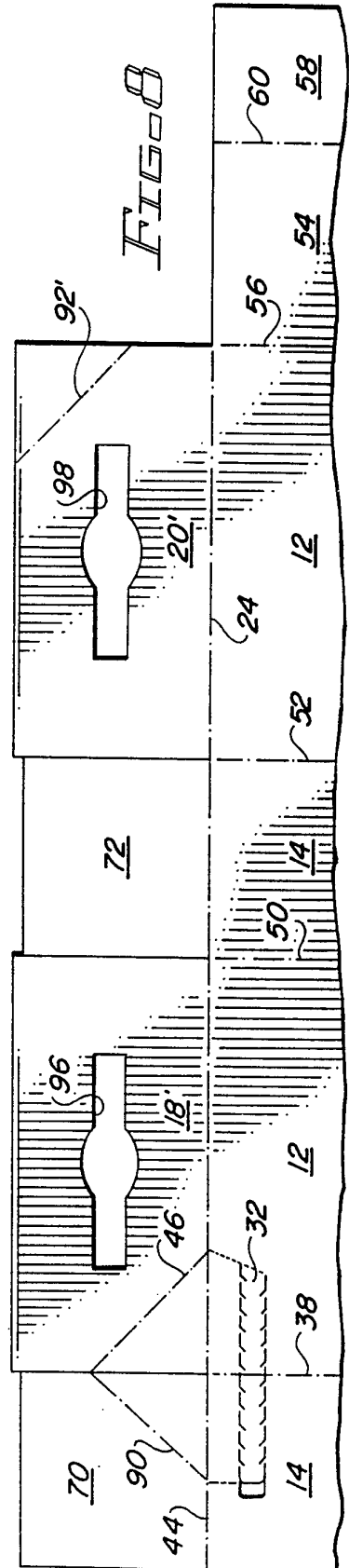

FIG. 8

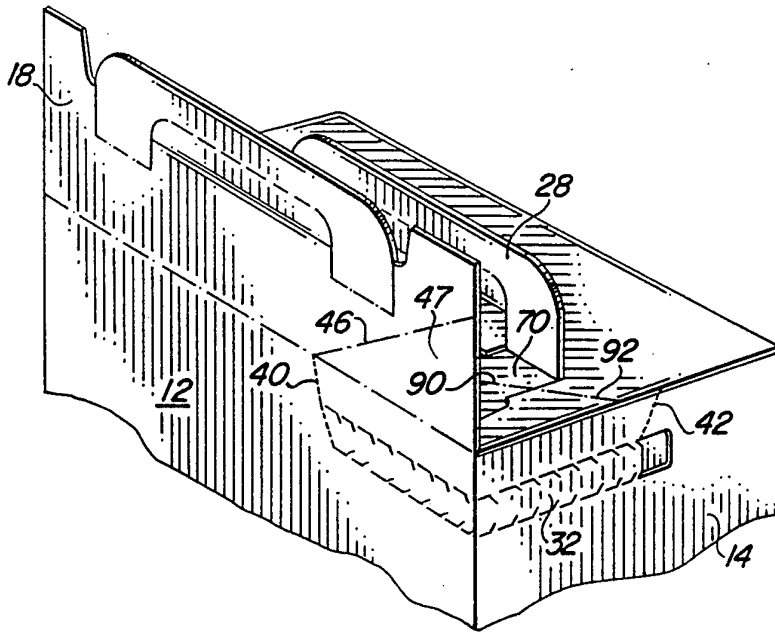

FIG. 5

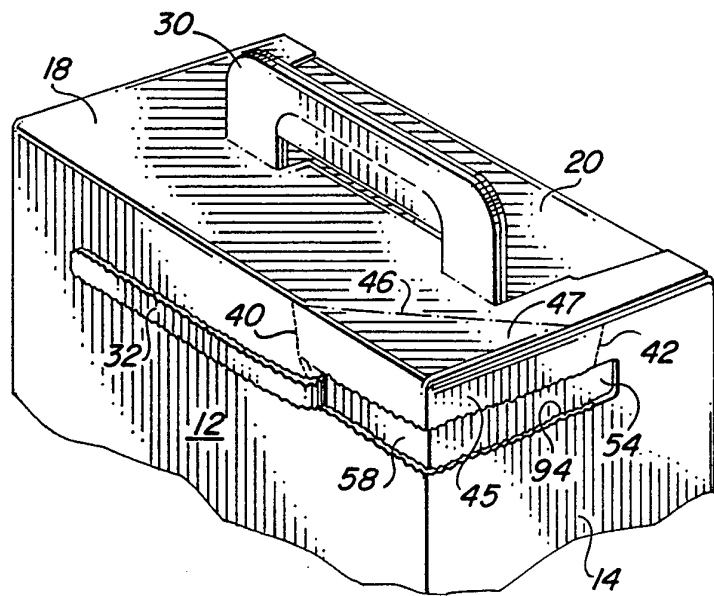

FIG. 6

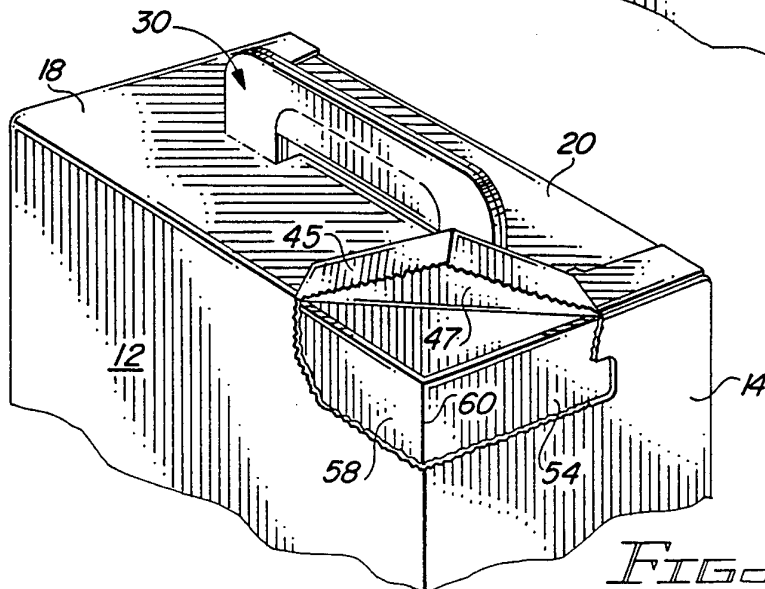

FIG. 7

INTERNATIONAL SEARCH REPORT

International application No.
PCT/US94/09079

A. CLASSIFICATION OF SUBJECT MATTER

IPC(5) :B65D 5/70

US CL :229/215, 231, 239

According to International Patent Classification (IPC) or to both national classification and IPC

B. FIELDS SEARCHED

Minimum documentation searched (classification system followed by classification symbols)

U.S. : 220/416; 229/214, 215, 217-219, 229, 231, 239

Documentation searched other than minimum documentation to the extent that such documents are included in the fields searched

Electronic data base consulted during the international search (name of data base and, where practicable, search terms used)

C. DOCUMENTS CONSIDERED TO BE RELEVANT

Category*	Citation of document, with indication, where appropriate, of the relevant passages	Relevant to claim No.
X -- Y	US, A, 4,913,292 (FIELD) 03 April 1990, col. 4, lines 10-29	1-4, 7,9-15 and 18 ----- 10, 14 and 18
X -- Y	US, A, 2,403,138 (SULLIVAN) 02 July 1946, col. 2, lines 32-42	1, 2, 4-6 and 11 ----- 10, 14, and 18

Further documents are listed in the continuation of Box C. See patent family annex.

* Special categories of cited documents:	*T	later document published after the international filing date or priority date and not in conflict with the application but cited to understand the principle or theory underlying the invention
A document defining the general state of the art which is not considered to be of particular relevance	*X*	document of particular relevance; the claimed invention cannot be considered novel or cannot be considered to involve an inventive step when the document is taken alone
E earlier document published on or after the international filing date	*Y*	document of particular relevance; the claimed invention cannot be considered to involve an inventive step when the document is combined with one or more other such documents, such combination being obvious to a person skilled in the art
L document which may throw doubts on priority claim(s) or which is cited to establish the publication date of another citation or other special reason (as specified)	*Z*	document member of the same patent family
O document referring to an oral disclosure, use, exhibition or other means		
P document published prior to the international filing date but later than the priority date claimed		

Date of the actual completion of the international search 24 SEPTEMBER 1994	Date of mailing of the international search report OCT 06 1994
--	---

Name and mailing address of the ISA/US Commissioner of Patents and Trademarks Box PCT Washington, D.C. 20231 Facsimile No. (703) 305-3230	Authorized officer STEPHEN P. GARBE Telephone No. (703) 308-1207	<i>Shirley H. Vance</i> Shirley H. Vance Patent Specialist Group 2400
---	--	--

INTERNATIONAL SEARCH REPORT

International application No.
PCT/US94/09079

C (Continuation). DOCUMENTS CONSIDERED TO BE RELEVANT		
Category*	Citation of document, with indication, where appropriate, of the relevant passages	Relevant to claim No.
X -- Y	US, A, 2,974,846 (STRUBLE) 14 March 1961, col. 3, lines 26-55	1, 2, 4-9, 11, 12, 14, 16 and 17 <hr/> 10 and 18
A	US, A, 2,773,634 (NEGORO) 11 December 1956	NONE