

E. M. ALDERMAN.
 ELECTROMAGNETIC GUN.
 APPLICATION FILED JUNE 8, 1908.

920,709.

Patented May 4, 1909.

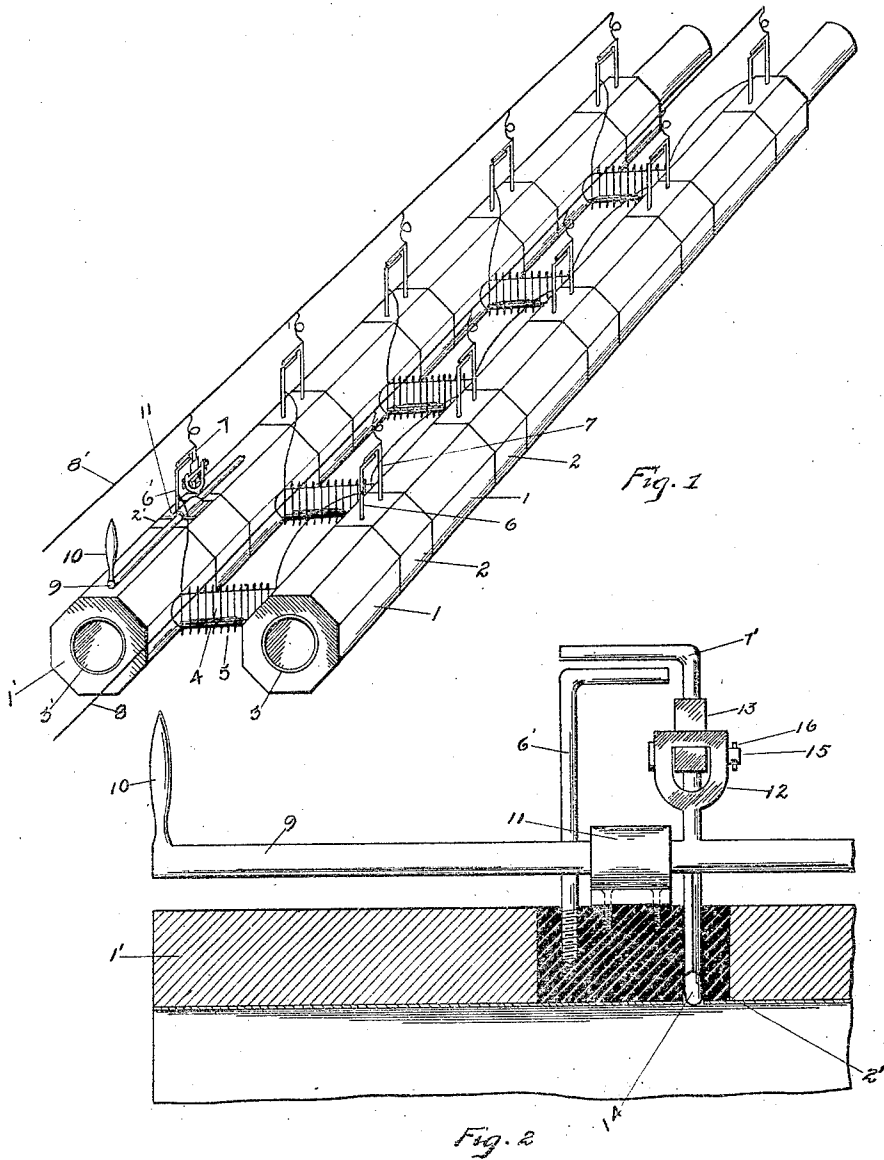

Witnesses
S. Roberts
Phyllis Williams

Inventor
E. M. Alderman
 per
Horace Williams
 Attorney

UNITED STATES PATENT OFFICE.

ELI M. ALDERMAN, OF SHARON, PENNSYLVANIA.

ELECTROMAGNETIC GUN.

No. 920,709.

Specification of Letters Patent.

Patented May 4, 1909.

Application filed June 8, 1908. Serial No. 437,374.

To all whom it may concern:

Be it known that I, ELI M. ALDERMAN, residing at Sharon, in the county of Mercer and State of Pennsylvania, have invented certain new and useful Improvements in an Electromagnetic Gun, of which the following is a full, clear, and exact description, such as will enable others skilled in the art to which it appertains to make and use the same.

This invention relates to guns for the firing or discharging of heavy projectiles and is directed more especially to improvements in those guns in which the force used to propel or discharge the projectile is the magnetism induced by an electric current, in contradistinction from those guns in which the propelling force is powder or some other explosive, or compressed air.

One of the objects of this invention is to provide means whereby a projectile is acted upon by but a single kind of magnetic force throughout its passage of the rifle, that is, allowing it to be subjected to either a positive or negative magnetic action but not to both.

Another object is to provide an electromagnetic gun in which a magnetism opposite to that possessed by the projectile is constantly acting upon the projectile during the passage of the latter through the gun.

A third object is to provide an electromagnetic gun to which a sufficiently large number of windings of heavy insulated wire may be applied without the gun being rendered impractical for actual service.

A further object is to provide an electromagnetic gun having a plurality of barrels, in which magnetic action is imparted to either or both barrels through a single set of coils.

A still further object is to provide means for closing the circuit of both barrels only at the instant of discharge of one or more projectiles, and for breaking the circuits at successive points along both barrels by the passage of a projectile through either barrel.

Further objects will be set forth in the specification following.

The invention accordingly consists in the features of construction, combinations of elements, and arrangement of parts which will be exemplified in the construction hereinafter set forth, and the scope of the application of which will be indicated in the following claims.

In the accompanying drawings wherein is illustrated one of the possible embodiments of my invention; Figure 1 is a perspective view of a double-barreled electromagnetic gun; Fig. 2 is a longitudinal sectional view taken on a vertical plane passing through the center of barrel I' of Fig. 1, the lower part of the barrel being broken away.

Referring to the two figures, it will be seen that either barrel is composed of a number of units I, I' separated by smaller units 2, 2'. The corresponding units I, I' of each barrel are united by means of the core 4, that is, each pair of opposite units or sections I, I' and the core, 4, connecting them are formed from an integral body of relatively soft iron, or other metal having the like property of being quickly magnetized or demagnetized.

Each pair of iron sections are separated from the next iron sections by insulating sections 2, 2'. The sections of each barrel are closely fitted upon an interior cylinder of brass or other non-magnetic metal. This cylinder 3 or 3' may be either rifled or of hexagonal shape. As both barrels are exactly similar in construction a description of the left hand barrel will suffice.

About the core 4 is wound insulated wire. As the greater the number of coils, the greater the magnetic effect produced is, I wind the cores heavily, the size of the coils being limited only by the distance between adjacent cores. As the diameter of the core is much less than that of the barrel, it will be seen that a heavy coil may be used without even exceeding the diameter of the barrels.

One end of the coil 5 is fixed to the post 6, while the other end is fixed to the post 6'. These posts 6, 6' are fastened in the insulating sections 2, 2'. Associated with each fixed post is a movable member 7, 7'. The member 7 or 7' has a limited sliding movement in the insulating 2 or 2'. In the lower position, the top, which is at right angles with the stem, of the member 7', is in contact with the top of the post 6', while the lower end of the stem, which has a cam shaped end, extends slightly through a hole in the inner cylinder 3'. To the members 7, 7' are attached wires connecting these members with the main wires or cables 8, 8'.

The wires 8, 8' are connected to a dynamo. It will thus be seen that when the opposite sliding members are in the lower position, a complete circuit exists, the current passing

from the dynamo (not shown) through wire 8 to the closed switch 7—6, through the coil 5, and back through 6', 7', and 8'. We thus have provided a circuit which can be broken 5 by raising either 7 or 7'. As previously stated the lower end of 7, 7', which is cam shaped, extends into the interior of the cylinder 3, 3'. As a projectile passes through either barrel it comes in contact with this 10 cam end and raises the member 7, 7', thus breaking the circuit. The member 7 or 7' being slidably mounted in the insulated section, it would, after the projectile had passed, tend to drop back and reclose the circuit. 15 To prevent this the following means are provided.

Along the upper side of the barrel and lying adjacent to the two parts of the switch a rod 9 extends. This rod is supported at 20 suitable intervals by brackets, said brackets being fastened by screws or other suitable means to certain of the insulated sections. Adjacent to each member 7, 7' and rigidly fixed to said rod is a fork shaped bracket 12, 25 upon which is pivotally mounted a pawl 13, by means of the pin 15 and cotter 16. The pawl 13, whose upper end is always in contact with the slide 7, 7', is adapted, upon the slide being raised, to drop into a shallow 30 notch in the slide.

As the pawls are each independently pivoted, the slides may be caught and held independently of each other. The arms upon which the pawls are pivoted are, however, all 35 rigidly fastened to the rod. It therefore follows from the above construction that by turning the handle 10 to the right the pawls will be simultaneously withdrawn and the slides all released and allowed to drop back 40 to the lower position at the same time. Springs may be provided to accelerate the downward movement of the slides and a spring of more or less strength may be applied to the rock shaft 9 to maintain the 45 brackets 12 in a normally upright position.

It will be understood that the construction of both barrels is similar and that the bracket and pawl is provided for each slide.

In the above construction the primary 50 principle of electromagnetic guns is included, namely having the entire barrel, with the exception of the insulated portions, magnetized at the start and causing the demagnetization of each section as the projectile traverses that particular section. 55

The particular advantages gained by the construction, the present embodiment of which has just been set forth, are as follows.

In the electromagnetic guns now proposed, 60 the coil is applied directly to the barrel. As is well known in this arrangement the opposite ends of each section, so wrapped, assume an opposite magnetism. The necessary effect of this is that the projectile in 65 passing through the barrel is subjected to

first a positive (or negative) magnetic influence, and then to its opposite.

Let us take the initial magnetism to be positive. The projectile, when subjected to the influence of a positive magnetism, will 70 acquire at that end, first presented, a negative magnetism, while the opposite end of the projectile will become a south pole. Now in advancing through this particular section 75 of the barrel, the projectile in approaching the opposite end of the section, presents to that end, which possesses a negative magnetism, the end of the projectile which has just acquired a negative magnetism. 80 The result is that there is a tendency of repulsion—like poles repelling—which must be overcome before the stronger negative magnetism of the electromagnet changes the magnetism at that end of the projectile to 85 positive. The same conditions are confronted upon the approach of every end of a section and it will be seen that a great amount of electrical energy will be consumed without imparting a corresponding increase 90 of velocity to the projectile.

The foregoing objection is overcome in the present invention. By connecting two sections by a core and wrapping this core with the required coils, the two barrel sections become respectively the north and south 95 poles of the magnet. This magnet, comprising two parallel and opposite sections and the connecting core, will of necessity have but two poles, depending upon the winding of the coil, and the two opposite 100 poles will lie in the the two opposite sections. It will thus be seen that by assembling a plurality of these magnets so that all the north poles will comprise one barrel and all 105 the south poles, the other, an electromagnetic gun is obtained in which a projectile during its passage through a barrel is subjected to the influence of but a single form of magnetism. The projectile, upon being 110 introduced into the receiving end of a barrel, will acquire a magnetism opposite in kind to that of the receiving end, and as the barrel throughout its entire length is either entirely positive or entirely negative in its 115 electromagnetic energy, the projectile will at no time in its passage through the barrel be effected by a magnetism of the same kind as that acquired by itself.

Other advantages obtained in the present invention will appear from an inspection of 120 the drawing and the principles embodied therein.

While I have described one method of carrying out my invention, it should be understood that various changes may be made 125 without departing from the spirit of my invention, which contemplates broadly an electromagnetic gun in which a barrel throughout its entire length is energized by a single kind of magnetism. 130

Having thus described my invention, what I claim as new and desire to secure by Letters Patent is:

1. In an electromagnetic gun, a barrel comprising only like poles of a series of magnets, substantially as shown and described.
2. In an electromagnetic gun, means for subjecting a projectile to a single polarity during the passage of the projectile through the gun, substantially as shown and described.
3. In an electromagnetic gun, means for maintaining a projectile in a uniform polarity during its passage through the gun, substantially as shown and described.
4. A double barreled electromagnetic gun comprising a series of electromagnets, each electromagnet constituting a single section of two barrels, substantially as shown and described.
5. A double barreled gun comprising a single series of electromagnets, substantially as shown and described.
6. A double barreled electromagnetic gun, each barrel being of a single polarity throughout, substantially as shown and described.
7. A double barreled electromagnetic gun, one barrel being of a negative polarity and the other barrel being of a positive polarity, substantially as shown and described.
8. A double barreled gun comprising a single series of electromagnets, the north poles of the magnets constituting one barrel and the south poles constituting the other barrel, substantially as shown and described.
9. A double barreled gun comprising a single series of electromagnets, the electromagnets being separated from each other by insulators, substantially as shown and described.
10. A double barreled gun comprising a plurality of independent sections, means for electrically energizing these sections and means for simultaneously deenergizing the corresponding sections in the two barrels, substantially as shown and described.
11. In a double barreled electromagnetic gun, a single means for imparting magnetism to both barrels, substantially as shown and described.
12. In a double barreled electromagnetic gun, a single magnet for simultaneously magnetizing both barrels, substantially as shown and described.
13. A double barreled electromagnetic gun comprising a plurality of magnetic sections and means for independently demagnetizing the corresponding sections of each barrel, substantially as shown and described.
14. In an electromagnetic gun, a barrel comprising alternately arranged conductors and non-conductors, means for imparting to the conductors a magnetism of a single and like polarity, substantially as shown and described.
15. An electromagnetic gun whose barrel comprises the same poles only of a plurality of electromagnets, substantially as shown and described.
16. In an electromagnetic gun, the combination of a barrel comprising a plurality of alternately arranged magnetic and insulating sections, switches positioned in the insulating sections for closing the circuit of each magnetic section, means for opening the switches independently of each other, independent means for maintaining the switches open, and means for simultaneously closing all the switches, substantially as shown and described.
17. In an electromagnetic gun, the combination of a barrel comprising a plurality of alternately arranged conducting and insulating sections, and electromagnets, half of whose poles lie in the barrel, all the conducting sections in the barrel being, when energized, of the same polarity, substantially as shown and described.
18. In a double barreled electromagnetic gun, a plurality of independent electromagnets, the opposite poles of each magnet lying in the two barrels respectively, a plurality of means on either barrel for independently breaking the circuit of any electromagnet, and means on either barrel for simultaneously closing the circuits of all the electromagnets, substantially as shown and described.
19. In a double barreled electromagnetic gun, the combination of a plurality of independent electromagnets and means, operated by the passage of a projectile through either barrel, for successively breaking the circuit of each of the electromagnets, substantially as shown and described.
20. In a double barreled electromagnetic gun, the combination of a plurality of independent electromagnets, each electromagnet comprising two parallel tubes and an iron core connecting said tubes and integral therewith, insulating sections alternating with said electromagnets, fixed posts in each of the insulating sections, wire coils surrounding said cores, the two ends of each coil being fastened respectively to two posts in the adjacent insulating sections of each barrel, sliding members mounted in the insulating sections and cooperating with the posts, and connections between the sliding members and the main source of current, the arrangement being such that upon the operation of any sliding member to non-contact with its post the circuit in the adjacent electromagnet is broken, substantially as shown and described.
21. In an electromagnetic gun, the combination of a plurality of alternating magnetic sections and insulators, switches positioned on each insulator, said switches comprising a fixed and a slidable member, a rock-shaft ex-

4
tending along the barrel of the gun and parallel therewith and adjacent to the switches, a plurality of rigid arms on said rock-shaft adjacent to each sliding member, pivoted pawls
5 on each arm, said pawls being adapted to lock the sliding member in raised position and means for releasing all of said sliding members simultaneously, the lower ends of said sliding members, when so released ex-

tending slightly into the interior of the barrel, substantially as shown and described. 10
In testimony whereof I affix my signature, in the presence of two witnesses.

ELI M. ALDERMAN.

Witnesses:

KATHERINE H. BUNDEL,
MAY MURCHIE.