

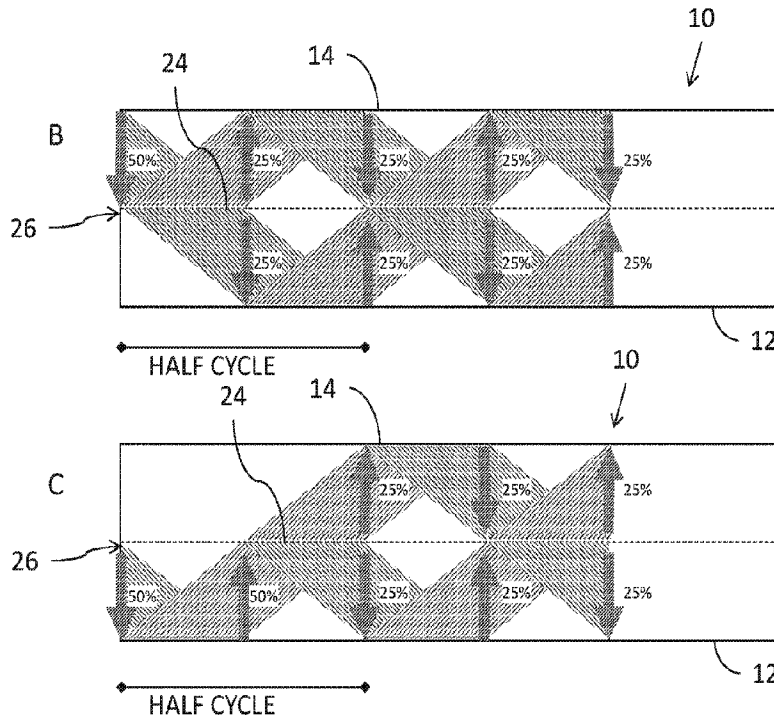

(86) Date de dépôt PCT/PCT Filing Date: 2020/07/05
 (87) Date publication PCT/PCT Publication Date: 2021/01/07
 (45) Date de délivrance/Issue Date: 2023/12/12
 (85) Entrée phase nationale/National Entry: 2022/01/03
 (86) N° demande PCT/PCT Application No.: IL 2020/050753
 (87) N° publication PCT/PCT Publication No.: 2021/001841
 (30) Priorité/Priority: 2019/07/04 (US62/870,699)

(51) Cl.Int./Int.Cl. *G02B 27/01* (2006.01),
G02B 6/10 (2006.01)
 (72) Inventeurs/Inventors:
RONEN, EITAN, IL;
CHRIKI, RONEN, IL;
MICHAELS, DANIEL, IL
 (73) Propriétaire/Owner:
LUMUS LTD., IL
 (74) Agent: INTEGRAL IP

(54) Titre : GUIDE D'ONDES D'IMAGE A MULTIPLICATION DE FAISCEAU SYMETRIQUE
 (54) Title: IMAGE WAVEGUIDE WITH SYMMETRIC BEAM MULTIPLICATION



(57) **Abrégé/Abstract:**

An optical system for displaying an image includes a waveguide (10) having two major surfaces (12, 14) that support propagation of image illumination by internal reflection. A coupling-out configuration (16, 18) couples out image illumination towards the eye of the user. An image projector (20) is coupled so as to introduce image illumination into the waveguide so as to propagate by internal reflection. The waveguide also contains a symmetrical beam multiplier region, distinct from the coupling-out region, having one or more beam splitters (24) internal to the waveguide and parallel to its major surfaces. The symmetrical beam multiplier may be used to fill in a conjugate image after a compact coupling-in configuration, and/or may be used to fill the waveguide with the image as an intermediate stage (36) between two optical aperture expansion configurations (32, 34).

(12) INTERNATIONAL APPLICATION PUBLISHED UNDER THE PATENT COOPERATION TREATY (PCT)

(19) World Intellectual Property Organization
International Bureau

(43) International Publication Date
07 January 2021 (07.01.2021)



(10) International Publication Number
WO 2021/001841 A1

- (51) International Patent Classification: G02B 27/01 (2006.01)
- (21) International Application Number: PCT/IL2020/050753
- (22) International Filing Date: 05 July 2020 (05.07.2020)
- (25) Filing Language: English
- (26) Publication Language: English
- (30) Priority Data: 62/870,699 04 July 2019 (04.07.2019) US
- (71) Applicant: LUMUS LTD. [IL/IL]; 8 Pinhas Sapir Street, 7403631 Ness Ziona (IL).
- (72) Inventors: RONEN, Eitan; Chaim Weizmann 13/13, Rehovot (IL). CHRIKI, Ronen; Haprahim st. 3, apt. 29,
- 7140903 Lod (IL). MICHAELS, Daniel; C/O Dr. Mark Friedman, 7 Jabotinsky Street, 5252007 Ramat Gan (IL).
- (74) Agent: FRIEDMAN, Mark; Moshe Aviv Tower, 54th floor, 7 Jabotinsky St., 5252007 Ramat Gan (IL).
- (81) Designated States (unless otherwise indicated, for every kind of national protection available): AE, AG, AL, AM, AO, AT, AU, AZ, BA, BB, BG, BH, BN, BR, BW, BY, BZ, CA, CH, CL, CN, CO, CR, CU, CZ, DE, DJ, DK, DM, DO, DZ, EC, EE, EG, ES, FI, GB, GD, GE, GH, GM, GT, HN, HR, HU, ID, IL, IN, IR, IS, IT, JO, JP, KE, KG, KH, KN, KP, KR, KW, KZ, LA, LC, LK, LR, LS, LU, LY, MA, MD, ME, MG, MK, MN, MW, MX, MY, MZ, NA, NG, NI, NO, NZ, OM, PA, PE, PG, PH, PL, PT, QA, RO, RS, RU, RW, SA, SC, SD, SE, SG, SK, SL, ST, SV, SY, TH, TJ, TM, TN, TR, TT, TZ, UA, UG, US, UZ, VC, VN, WS, ZA, ZM, ZW.
- (84) Designated States (unless otherwise indicated, for every kind of regional protection available): ARIPO (BW, GH, GM, KE, LR, LS, MW, MZ, NA, RW, SD, SL, ST, SZ, TZ,

(54) Title: IMAGE WAVEGUIDE WITH SYMMETRIC BEAM MULTIPLICATION

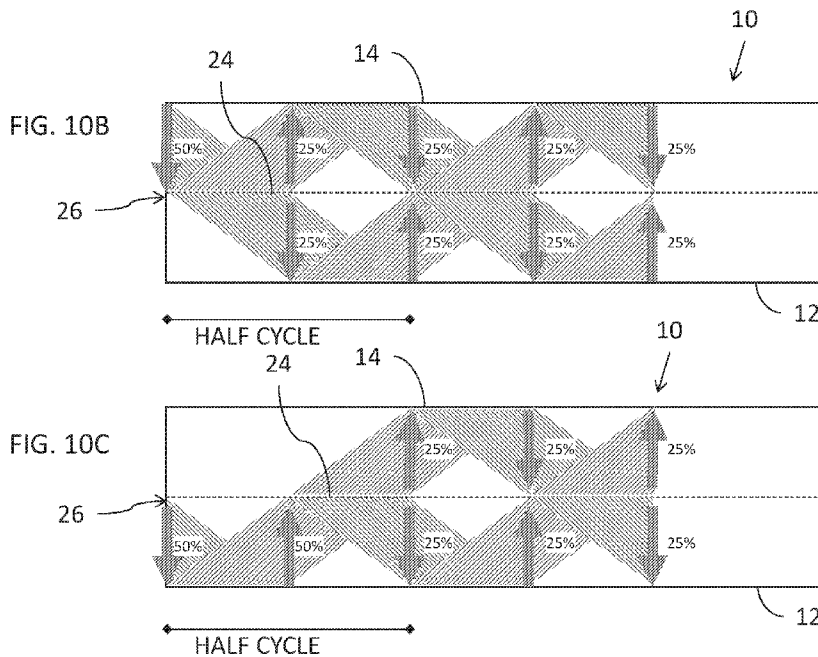

(57) Abstract: An optical system for displaying an image includes a waveguide (10) having two major surfaces (12, 14) that support propagation of image illumination by internal reflection. A coupling-out configuration (16, 18) couples out image illumination towards the eye of the user. An image projector (20) is coupled so as to introduce image illumination into the waveguide so as to propagate by internal reflection. The waveguide also contains a symmetrical beam multiplier region, distinct from the coupling-out region, having one or more beam splitters (24) internal to the waveguide and parallel to its major surfaces. The symmetrical beam multiplier may be used to fill in a conjugate image after a compact coupling-in configuration, and/or may be used to fill the waveguide with the image as an intermediate stage (36) between two optical aperture expansion configurations (32, 34).



WO 2021/001841 A1

WO 2021/001841 A1 

UG, ZM, ZW), Eurasian (AM, AZ, BY, KG, KZ, RU, TJ, TM), European (AL, AT, BE, BG, CH, CY, CZ, DE, DK, EE, ES, FI, FR, GB, GR, HR, HU, IE, IS, IT, LT, LU, LV, MC, MK, MT, NL, NO, PL, PT, RO, RS, SE, SI, SK, SM, TR), OAPI (BF, BJ, CF, CG, CI, CM, GA, GN, GQ, GW, KM, ML, MR, NE, SN, TD, TG).

Published:

- *with international search report (Art. 21(3))*
- *before the expiration of the time limit for amending the claims and to be republished in the event of receipt of amendments (Rule 48.2(h))*

Image Waveguide with Symmetric Beam Multiplication

FIELD AND BACKGROUND OF THE INVENTION

The present invention relates to optical systems and, in particular, it concerns image display systems employing a waveguide in which beams of illumination are
5 symmetrically multiplied.

As an exemplary context for implementations of the present invention, various optical displays employ a light-guide optical element (LOE) (interchangeably referred to as a “waveguide” or a “substrate”) for conveying an image from an image projector opposite the eye of a user, where it is coupled out, typically by an arrangement of
10 partial reflectors or by a diffractive optical element, towards the eye.

In order to achieve uniformity of the viewed image, the waveguide should be uniformly “filled” with the projected image and its conjugate image. This imposes design limitations on the size of the image projector and various other aspects of the optical design.

15 SUMMARY OF THE INVENTION

The present invention is a light-guide optical system with symmetric beam multiplication.

According to the teachings of an embodiment of the present invention there is provided, an optical system for displaying an image to an eye of a user comprising:
20 (a) a light-guide optical element (LOE) having two planar major external surfaces that are parallel so as to support propagation of image illumination within the LOE by internal reflection at the major external surfaces; (b) a coupling-out configuration associated with a coupling-out region of the LOE and configured for coupling out at least part of the image illumination from the LOE towards the eye of the user; and
25 (c) an image projector for generating image illumination corresponding to a collimated image, the image projector being optically coupled to the LOE so as to introduce the image illumination into the LOE so as to propagate within the LOE by internal reflection, wherein the LOE further comprises a symmetrical beam multiplier region, distinct from the coupling-out region, the symmetrical beam multiplier region having n

internal planar beam splitters, where n is a positive integer, each beam splitter being internal to the LOE and parallel to the major external surfaces, the n beam splitters subdividing a thickness of the LOE between the major external surfaces into $(n+1)$ layers of equal thickness, and wherein the LOE and/or coupling of the image projector to the LOE are configured such that the image illumination entering the symmetrical beam multiplier region either: (i) fills at least two of the layers with image illumination corresponding to the collimated image without a conjugate of the collimated image, or with the conjugate of the collimated image without the collimated image, or (ii) fills only one of the layers with image illumination corresponding to both the collimated image and a conjugate of the collimated image.

According to a further feature of an embodiment of the present invention, the LOE has an input aperture that is perpendicular to the major external surfaces, and wherein the n beam splitters extend up to the input aperture, and wherein the image projector is optically coupled to the input aperture so as to fill the input aperture with the collimated image without the conjugate of the collimated image.

According to a further feature of an embodiment of the present invention, the LOE has an input aperture that corresponds to one of the layers, and wherein the image projector is optically coupled to the input aperture so as to fill the one of the layers with the collimated image and the conjugate of the collimated image.

According to a further feature of an embodiment of the present invention, $n = 1$, and wherein a reflectivity of the beam splitter is $1/2$.

According to a further feature of an embodiment of the present invention, $n = 2$, and wherein a reflectivity of a first of the beam splitters is $1/2$ and a reflectivity of a second of the beam splitters is $1/3$.

According to a further feature of an embodiment of the present invention, the coupling-out configuration comprises a plurality of mutually-parallel partially reflecting surfaces deployed within the LOE and obliquely oriented relative to the major external surfaces.

According to a further feature of an embodiment of the present invention, the coupling-out configuration comprises at least one diffractive optical element associated

with the LOE and configured for progressively coupling out a part of the image illumination towards the eye of the user.

There is also provided according to a further feature of an embodiment of the present invention, an optical system for displaying an image to an eye of a user comprising: (a) a light-guide optical element (LOE) having two planar major external surfaces that are parallel so as to support propagation of image illumination within the LOE by internal reflection at the major external surfaces; (b) a coupling-in region for introduction of image illumination corresponding to a collimated image into the LOE so as to propagate within the LOE in a first propagation direction; (c) a coupling-out configuration associated with a coupling-out region of the LOE and configured for coupling out at least part of the image illumination from the LOE towards the eye of the user; (d) an aperture expansion configuration associated with the LOE and configured to progressively redirect the image illumination from the first propagation direction so as to propagate within the LOE in a second propagation direction towards the coupling-out configuration; and (e) a symmetrical beam multiplier region, interposed between the aperture expansion configuration and the coupling-out region, the symmetrical beam multiplier region having n internal planar beam splitters, where n is a positive integer, each beam splitter being internal to the LOE and parallel to the major external surfaces, the n beam splitters subdividing a thickness of the LOE between the major external surfaces into $(n+1)$ layers of equal thickness.

According to a further feature of an embodiment of the present invention, the n internal planar beam splitters are implemented as n angularly-selective beam splitters having a first reflectivity for a range of angles corresponding to the image illumination propagating within the LOE, and a second reflectivity, lower than the first reflectivity, for small angles of incidence.

According to a further feature of an embodiment of the present invention, the aperture expansion configuration comprises a plurality of mutually-parallel partially reflecting surfaces deployed within the LOE and obliquely oriented relative to the major external surfaces.

According to a further feature of an embodiment of the present invention, the coupling-out configuration comprises a plurality of mutually-parallel partially reflecting

surfaces deployed within the LOE and obliquely oriented relative to the major external surfaces, the partially reflecting surfaces of the coupling-out configuration being non-parallel to the partially reflecting surfaces of the aperture expansion configuration.

According to a further feature of an embodiment of the present invention, the aperture expansion configuration comprises at least one diffractive optical element associated with the LOE and configured for progressively redirecting a part of the image illumination from the first propagation direction to the second propagation direction.

According to a further feature of an embodiment of the present invention, the coupling-out configuration comprises at least one diffractive optical element associated with the LOE and configured for progressively coupling out a part of the image illumination towards the eye of the user.

BRIEF DESCRIPTION OF THE DRAWINGS

The invention is herein described, by way of example only, with reference to the accompanying drawings, wherein:

FIGS. 1A and 1B are schematic side views illustrating an image-projecting waveguide system with symmetric beam multiplication according to an embodiment of the present invention, employing reflective and diffractive beam directing components, respectively;

FIG. 2 is a schematic side view of a waveguide employing a coupling-in wedge according to a conventional coupling-in geometry;

FIGS. 3A and 3B illustrate the results of different size illumination apertures introduced into the waveguide of FIG. 2 achieving full and partial filling of the waveguide, respectively;

FIGS. 4A and 4B are schematic representations of stages in the production of the image-projecting waveguide system with symmetric beam multiplication of FIG. 1A;

FIGS. 5A-5C are schematic representations of types of coupling-in configuration for the waveguide of FIGS. 1A or 1B, exhibiting a controlled asymmetry;

FIG. 6 is a schematic side view illustrating a first preferred configuration for coupling an image projector to the image-projecting waveguide system with symmetric beam multiplication of FIG. 1A;

FIG. 7 is a schematic side view illustrating a second preferred configuration for coupling an image projector to the image-projecting waveguide system with symmetric beam multiplication of FIG. 1A;

FIGS. 8A and 8B are a side view and a front view, respectively, of the configuration of FIG. 7 corresponding to a model used for ray tracing simulation;

FIG. 8C is a view similar to FIG. 8A illustrating the output of the image-projecting waveguide system for asymmetric coupled-in image illumination;

FIG. 9 is a schematic representation of the illumination pattern within a waveguide for asymmetric coupled-in image illumination lacking a conjugate image;

FIG. 10A is a schematic representation similar to FIG. 9 illustrating the effect of a symmetric beam multiplier according to an aspect of the present invention;

FIGS. 10B and 10C are views similar to FIG. 10A, but illustrating separately the intensity distribution resulting from the illumination of each part of the aperture as it propagates through the symmetric beam multiplier;

FIGS. 11A and 11B are views similar to FIGS. 10B and 10C for a symmetric beam multiplier having two beam splitters dividing the thickness of the waveguide into three layers, where two layers are illuminated with image illumination without a conjugate image;

FIG. 12A is a schematic side view of an optical arrangement in which an image projector fills a thin waveguide with both an image and its conjugate, and the image is then expanded to a thicker waveguide by a symmetric beam multiplier, according to a further aspect of the present invention;

FIGS. 12B and 12C are representations similar to FIGS. 11A and 11B illustrating the propagation of the image and its conjugate through the symmetric beam multiplier of FIG. 12A;

FIG. 13A is a schematic representation similar to FIG. 10C for a symmetric beam multiplier having three beam splitters dividing the thickness of the waveguide

into four layers, illustrating propagation of one image in one layer of the aperture through the symmetric beam multiplier;

FIGS. 13B and 13C are views similar to FIG. 13A illustrating the effects of employing equal reflectivity of 0.25 or 0.5 for each beam splitter;

5 FIGS. 14A and 14B are a side view and a front view, respectively, of a waveguide for two-dimensional optical aperture expansion employing an intermediate symmetrical beam multiplier between two stages of aperture expansion;

10 FIGS. 15A and 15B are schematic side views illustrating the distribution of illumination within the waveguide of FIG. 14A, without and with the symmetrical beam multiplier, respectively; and

FIG. 16 is a schematic isometric representation of a display system with two-dimensional aperture expansion which employs a first symmetrical beam multiplier associated with a coupling-in aperture and a second symmetrical beam multiplier intermediately positioned between two stages of optical aperture expansion.

15 DESCRIPTION OF THE PREFERRED EMBODIMENTS

The present invention is a light-guide optical system with symmetric beam multiplication.

20 The principles and operation of optical systems according to the present invention may be better understood with reference to the drawings and the accompanying description.

Referring now to the drawings, FIGS. 1A and 1B illustrate schematically a typical implementation of an optical system for displaying an image to an eye 100 of a user, located within a region referred to as the eye motion box (EMB) 102. The system includes a light-guide optical element (LOE) 10 (interchangeably referred to as a
25 “waveguide” or a “substrate”) having two planar major external surfaces 12, 14 that are parallel so as to support propagation of image illumination within the LOE by internal reflection at the major external surfaces. A coupling-out configuration is associated with a coupling-out region of LOE 10, and is configured for coupling out at least part of the image illumination from the LOE towards the eye 100 of the user. In certain
30 embodiments, the coupling-out configuration is implemented as a set of mutually-

parallel partially reflecting surfaces 16, deployed within the LOE and obliquely oriented relative to the major external surfaces, as illustrated in FIG. 1A. In other embodiments, the coupling-out configuration is implemented as at least one diffractive optical element 18 associated with LOE 10 and configured for progressively coupling out a part of the image illumination towards the eye of the user, as illustrated in FIG. 1B.

An image projector 20, interchangeably referred to as a “POD”, generates image illumination corresponding to a collimated image. Image projector 20 is optically coupled to LOE 10 so as to introduce the image illumination into the LOE so as to propagate within the LOE by internal reflection. The POD employed with the devices of the present invention is preferably configured to generate a collimated image, i.e., in which the light of each image pixel is a parallel beam, collimated to infinity, with an angular direction corresponding to the pixel position. The image illumination thus spans a range of angles corresponding to an angular field of view in two dimensions.

Image projector 20 includes at least one light source, typically deployed to illuminate a spatial light modulator, such as an LCOS chip. The spatial light modulator modulates the projected intensity of each pixel of the image, thereby generating an image. Alternatively, or additionally, the image projector may include a scanning arrangement, typically implemented using a fast-scanning mirror, which scans illumination from a laser light source across an image plane of the projector while the intensity of the beam is varied synchronously with the motion on a pixel-by-pixel basis, thereby projecting a desired intensity for each pixel. In both cases, collimating optics are provided to generate an output projected image which is collimated to infinity. Some or all of the above components are typically arranged on surfaces of one or more polarizing beam-splitter (PBS) cube or other prism arrangement, employing reflective optics, as is well known in the art. Alternatively, a free-space optics implementation with reflective and/or refractive optics may be used. Details of the image projector are not per se part of the present invention, and in order to simplify presentation, the image projector is represented here schematically as a dashed box, without any attempt to illustrate the individual components.

Optical coupling of image projector 20 to LOE 10 may be achieved by any suitable optical coupling, such as for example via a coupling prism with an obliquely

angled input surface, or via a reflective coupling arrangement, via a side edge and/or one of the major external surfaces of the LOE. Examples of coupling in via a wedge prism may be found in PCT publication no. WO2015162611. Various examples of coupling in using a mirror may be found in PCT publication no. WO2001095027.

5 Except where otherwise specified below, details of the coupling-in configuration are typically not critical to the invention, and are shown here schematically as a non-limiting example of a wedge prism **22** applied to an edge surface of LOE **10**. Furthermore, implementations of the present invention that are illustrated herein using a coupling-in prism can equally be implemented using a reflective coupling-in

10 arrangement, and vice versa. The coupling-in configuration determines an angle between the POD and the LOE, denoted as α_{pod} in FIG. 2.

FIGS. 2 and 3A illustrate a coupling-in configuration employing a wedge prism **22** according to a conventional approach. The LOE should provide image illumination to the human eye in a uniform distribution over all propagating angles of light (also referred to as “fields” or “field of view” - FOV) and throughout the EMB **102**. To this

15 end, each field’s aperture should be evenly filled with light. In other words, for any angle of illumination, corresponding to a pixel within the collimated image, the entire cross-section of the LOE in a plane perpendicular to the major surfaces of the LOE should be filled with both the image and its reflection (conjugate) such that, at any point

20 in the LOE volume, rays are present corresponding to all pixels of both the collimated image and its conjugate. In order to achieve this result, as illustrated in FIG. 3A, a relatively large-aperture image projector **20** is used together with an extension to one major surface **12** of the LOE so that the aperture of LOE **10** received full direct illumination of the image and full reflected illumination of the conjugate image

25 internally reflected from surface **12**. Image projector **20** must have a correspondingly large aperture to fill the LOE aperture in this manner.

If the “filling” condition is not met, the light shined into the eye will not be evenly distributed. An example of a narrow illumination beam which fails to meet this criterion is shown in FIG. 3B, where a smaller image projector **20** is used with an

30 optical configuration that is otherwise similar to FIG. 3A. When there is a lack of aperture filling, the light exiting the LOE will not be evenly distributed. Non-uniformity

of filling of the LOE can occur for a number of reasons, including but not limited to, use of a small aperture projector, use of a small coupling-in geometry, and certain configurations of internal facet reflections.

An aspect of the present invention illustrated in FIGS. 1A, 1B and 4A-16 relates to a range of configurations in which light of a collimated image is guided by, but does not completely fill, a light-guide optical element (LOE) having a pair of major parallel external surfaces, and in particular, where the image propagates without being an image/image-conjugate pair at every point along the LOE. In such situations, according to an aspect of the present invention, it has been found particularly effective to provide LOE 10 with a symmetrical beam multiplier region, distinct from the coupling-out region, the symmetrical beam multiplier region having n internal planar beam splitters 24, where n is a positive integer, each beam splitter 24 being internal to LOE 10 and parallel to the major external surfaces 12, 14. The n beam splitters subdivide a thickness of the LOE between the major external surfaces into $(n+1)$ layers of equal thickness. Thus, in a simplest and particularly preferred example of $n = 1$, beam splitter 24 is implemented as a partial reflecting surface located on a mid-plane between the two major external surfaces, and most preferably, where the partially reflecting surface has a reflectivity of about 50%. Such a symmetrical beam multiplier region is typically implemented by providing the beam splitter as a coating on one plate and then bonding that plate with another similar plate, as illustrated in FIG. 4A. The beam multiplier region is then integrated with other elements to form the overall LOE structure, as illustrated schematically in FIG. 4B.

It has been found that the symmetrical beam multiplier of the present invention has a particular synergy with certain particular asymmetric forms of partial filling of the LOE, where the symmetry of the beam multiplication rapidly achieves full beam uniformity over a short distance. Particularly significant scenarios of such synergy are where the configuration of LOE 10 and/or the coupling of image projector 20 to LOE 10 are such that the image illumination entering the symmetrical beam multiplier region either: (i) fills at least two of the layers with image illumination corresponding to the collimated image without a conjugate of the collimated image (FIG. 5B), or with the conjugate of the collimated image without the collimated image (FIG. 5C), or (ii) fills

only one of the layers with image illumination corresponding to both the collimated image and a conjugate of the collimated image (FIG. 5A).

A typical scenario of one type of asymmetry optimally addressed by this aspect of the present invention is illustrated in FIG. 9 where, at an arbitrary starting point taken as the left edge of the LOE as illustrated, light corresponding to a certain field (angular direction, corresponding to a particular pixel) of a collimated image is present across the entire thickness of the LOE propagating in a downwards direction as shown, but the corresponding field of the conjugate image is missing. The downward-propagating image is represented here by a downwards arrow while its upward-propagating conjugate image is represented by an upwards arrow. A region in which the images are mixed is represented by a double-headed arrow. The light propagates towards the right as shown, undergoing total internal reflection at the bottom major surface of the LOE to be converted to the conjugate image, which propagates angled upwards until reflected off the upper surface to again generate the original image. (This process continues beyond what is illustrated here, until the light is coupled out of the LOE.) It is immediately visible that the image and its conjugate do not “fill” the thickness of the LOE. In fact, in this scenario, each of the image and its conjugate are present in half of the volume of the LOE (in the cross-section where the image is propagating), overlapping with each other in some regions and with some totally “dark” regions (which are unshaded in this representation).

A mid-plane 50% mixer has been found to achieve very rapid “filling in” of the missing conjugate image so that, within a very short distance, complete filling of the LOE is achieved, as illustrated in FIG. 10A. The length required to achieve this mixing is ideally no more than half of one cycle of the most shallow-angled rays of the image bouncing between top and bottom surfaces of the LOE. This extremely rapid filling of the LOE with a uniform illumination pattern of both images is a result of the particular synergy mentioned above between a controlled asymmetrical state at the input to the symmetric beam multiplier and the symmetry of the beam multiplier itself.

The mechanism by which this completion of the missing conjugate images and redistribution of image intensity occurs is illustrated schematically in FIGS. 10B and 10C by considering separately the image illumination intensity and direction of

propagation for the upper and lower halves of the LOE. FIG. 10B illustrates the intensity distribution between the upper and lower halves of the LOE for image intensity starting in the upper half of the LOE propagating downwards while FIG. 10C shows the same for the image starting downwards in the lower half of the waveguide.

5 Although an entire “cycle” along the LOE is illustrated, it will be noted that uniform image intensity distribution is achieved already after a half cycle. From the directions of the arrows (representing the direction of propagation corresponding to either the primary image or the conjugate), it will be appreciated that the entire LOE is also filled with both images. (Throughout this document, it should be noted that the “primary

10 image” and the “conjugate image” are arbitrarily identified, and are interchangeable, meaning that either, or in some cases both, can be used to convey the image to the observer, and the image projected towards the user may be the same image as injected from the image projector, or may be its conjugate.)

Although this aspect of the invention has been illustrated thus far primarily with reference to a single partial reflector deployed on a mid-plane of the LOE dividing it into two equal parts, it should be noted that the principles can be generalized to “ n ” partial reflectors deployed parallel to the major surfaces of the LOE such that they divide the thickness equally into “ $n+1$ ” sections for $n=1, 2, 3$ etc. In this case, the preferred reflectivities for successive reflectors are $1/2, 1/3, \dots 1/(n+1)$. By way of

20 example, FIGS. 11A and 11B illustrate the intensity distribution and conjugate image filling for a waveguide subdivided into 3 parts by two partial reflectors with reflectivities $1/2$ and $1/3$, and where an image without its conjugate are injected into two of the three layers of the LOE. Here too, in the example illustrated, the intensity of distribution rapidly becomes uniform within half a cycle, and when injected into two of

25 the three layers, has generated both the image and its conjugate over the entire LOE thickness. For simplicity of representation, the input intensity for each layer/third of the thickness has been labeled as 100%.

It will be understood that the reflectances of the various partial reflectors have been identified by their desired values, but the proportion of reflectance is a parameter

30 which may not be precisely defined or precisely achievable in all cases, and the intention here is to refer to values sufficiently close to the theoretical value (e.g., 0.5)

that the resulting intensity distribution if sampled would be perceived visually as uniform across the thickness of the LOE. For a single reflecting layer ($n=1$), a reflectivity of $R=0.5+\Delta$ will result after half a cycle in an intensity difference of Δ between the image and conjugated image; and, more generally, after m half-cycles, it will result in an intensity difference of $(m-1)*\Delta^m$. Typically, Δ of 5-10% are visually acceptable even only after one half-cycle. variations of $\pm 5\%$, or even $\pm 10\%$ in the reflectances may in certain cases render results which are sufficiently close to optimum to be visually acceptable. Parallelism between the partial reflector layer(s) and the major external surfaces of the LOE should be preserved, and the subdivision of the thickness into equal portions is preferably performed to an accuracy of within 10%, and preferably more accurately, in order to avoid generating stripes of non-uniform intensity during the beam multiplication process.

Structurally, the partial reflectivity of the beam multiplying configuration can be implemented using any suitable partially-reflective layer or coating, including but not limited to, a metallic coating, a structural partial reflector (e.g., polka-dot patterned reflector) and multi-layer dielectric coatings. If it is desired to deploy the partial reflector layer in a region through which the observer sees an external "real" scene (particularly although not exclusively relevant to certain embodiments illustrated below with reference to FIGS. 14A-16), the partially-reflective coatings are preferably implemented using an angle-dependent reflective coating in which the coating has 50% reflectivity (or the corresponding desired reflectivity according to the sequence described above, for multiple beam-splitter implementations) at angles in a range corresponding to angles of image light propagation within the LOE while having low reflectivity at small angles (close to perpendicular to the beam splitter), so as to provide less attenuation of light from the directly viewed scene. Layers with such angle-dependent reflectance can readily be achieved using multi-layer dielectric coatings, and are easy to manufacture since the required properties are essentially similar to Fresnel reflection properties. Design of multi-layer coatings to provide such angularly-dependent reflectivity can be performed using standard software packages, as is common practice in the art, and suitable coatings can be obtained commercially from

many sources. Accordingly, for conciseness of presentation, the details will not be addressed here.

Optimal uniformity between the primary image and the conjugate image in this case is achieved by injecting the image via a coupling-in aperture covering 2/3 of the thickness of the LOE (either top 2/3 or bottom 2/3 or middle third with part of top and bottom thirds).

FIG. 12A illustrates schematically an alternative form of input state which has particular synergy with the symmetrical beam multiplier of the present invention, namely, where one layer of the LOE is filled with both the image and its conjugate while the other layers are initially without image illumination. FIGS. 12B and 12C illustrate the distribution of the image and conjugate image through the symmetric beam multiplier, which begins at the point at which the LOE thickness increases. In this case, the downward-propagating image as illustrated takes 2/3 of a cycle to reach full uniformity. This would be shortened in this case if the 1/2 and 1/3 reflectors were interchanged. This scenario facilitates use of a small projector aperture and coupling prism, since coupling-in need only be achieved for a relatively thin layer, and may be useful in any situation where it is desired to increase the thickness of an LOE.

FIG. 13A illustrates a further example, with 3 reflectors having reflectance 1/4, 1/3 and 1/2, respectively, dividing an LOE thickness into 4 equal portions), and illustrates the part of the aperture which takes the longest length along the LOE to equalize its intensity across the thickness of the LOE, still taking less than a single cycle of reflection between the top and bottom surfaces of the LOE. Such an example can provide uniform filling of the thickness of the LOE using an input aperture which provides only one image (without its conjugate) over a thickness of half the thickness of the LOE, or across the entire thickness of the LOE, whichever is preferred, or which provides a full coupling of the image and its conjugate into one layer.

It is noted that the particular sequence of reflectivities disclosed achieves rapid equalization of illumination intensity in a manner that cannot be achieved using multiple beam splitters with equal partial reflectance. By way of comparative examples, FIGS. 13B and 13C are cases similar to FIG. 13A where all three of the partially reflective layers have the same reflectance of either 0.25 (FIG. 13B) or 0.5 (FIG. 13C).

In both cases, the intensity distribution is still far from uniform after the same path length that achieved uniformity in FIG. 13A.

As mentioned, optimal performance of the symmetric beam multiplier is achieved when the input illumination has a well-defined asymmetry which is has synergy with the beam multiplier structure. For this reason, in a first set of particularly preferred implementations, beam splitters 24 extend up to an input aperture 26 of LOE 10, which is advantageously perpendicular to the major external surfaces 12, 14. According to certain implementations of the present invention, image projector 20 is optically coupled to input aperture 26 so as to fill the input aperture with the collimated image without the conjugate of the collimated image. Two exemplary configurations for achieving such optical coupling are illustrated schematically in FIGS. 6 and 7.

In FIG. 6, a coupling prism 22 provides a coupling-in surface roughly perpendicular to a central (nominal) ray of an image from image projector 20, and allows the image to enter input aperture 26 without prior reflection. The coupled-in image is a single image without a conjugate, and the symmetric beam multiplier reconstructs the image/conjugate combination as described.

FIG. 7 illustrates a functionally similar arrangement where a coupling-prism 22' is configured to provide a surface at which the image undergoes one reflection before reaching the perpendicular input aperture 26 of the LOE. This configuration facilitates an orientation of the image projector which extends at a large angle to the plane of the LOE, and with minimum bulk extending beyond the end of the LOE, which may be particularly advantageous for certain practical implementations, particular for near-eye displays which adopt an eyeglass frame form.

FIGS. 8A and 8B are a side and front view, respectively, of an implementation of the device of FIG. 7 showing the relative position of the EMB 102 to LOE 10, and FIG. 8C is the result of ray-tracing software analyzing a particular pixel field of an image projected through this design. It is seen that the coupled-in image is delivered uniformly to the EMB, despite the coupling-in providing an image without its conjugate.

The compactness of these coupling-in configurations is better understood by comparing them to the conventional approach illustrated in FIGS. 2 and 3A. In that

case, where one face of the LOE is extended beyond the LOE aperture to provide a coupling-in wedge to fill the aperture with both the image and its conjugate, especially when having very large (grazing) propagating angles the coupling-in mechanism has two main problems:

- 5 1. The size of wedge is large, since it is comparable to $d \tan(\phi_m)$ which increases dramatically when ϕ_m approaches grazing angles.
2. The angle between LOE and the POD is governed by the central FOV propagation $\alpha_{pod} = 90 + \phi_c$ (where ϕ_c is the central FOV propagation angle) could be very not attractive for some systems. For instance. For side pod
 10 systems (glasses like) α_{pod} is desirable to be about 110 degrees and when $\phi_c = 60^\circ$ then $\alpha_{pod} = 150^\circ$

In contrast, since the arrangements of FIGS. 6 and 7 couple in only one image, without its conjugate, through a perpendicular input aperture 26, the size of the coupling prism 22 is no longer relative to $\tan(\phi_m)$ but rather to its cosine
 15 function: $\cos(\phi_m)$. Where a folding facet is used to break the light propagating angle and change α_{pod} , as shown in Fig 7, this introduces an additional degree of freedom in the geometrical design. In the example illustrated here, the central propagation angle of the image entering the input aperture of the waveguide is 60 degree, but due the folding prism serving as a wedge, the pod angle α_{pod} is 106.5, with a relatively small aperture
 20 size.

Due to the rapid equalization of the image intensity across the LOE thickness using the particular configurations defined herein, the beam multiplication arrangement of the present invention may optionally be deployed selectively along a relatively short
 25 section of the LOE, which may typically be no more than about 5 times the thickness of the LOE, and in some cases no more than 3 times the thickness of the LOE. Although use of a longer partially reflective surface does not adversely affect the uniformity of the beam filling, the ability to achieve effective beam multiplication over a short length of the LOE provides profound advantages with regard to compactness of design, minimizing any scattering effects of the reflectors, and keeping the partial reflectors
 30 outside the viewing region of the LOE through which the observer views the real world.

This aspect of the present invention may be used to advantage in a wide range of contexts and configurations to facilitate compact and efficient system design in situations where arrangements for filling an LOE directly with an image and its conjugate is either unfeasible or cannot be done without compromise of other design considerations such as size and/or form factor.

The required length of beam splitter 24 for the 50% mid-plane beam splitter configuration is typically half of the biggest aperture (i.e., half a cycle) from all parts of the field propagating in the LOE. This length is given by $L_m = 0.5d \tan(\phi_m)$ where d is the thickness of the LOE and ϕ_m is the biggest propagation angle of all fields relative to the normal of the LOE (see Fig. 3B).

Structurally the mixer is typically produced by optically bonding a corresponding number of layers having the required beam splitter coatings applied to one of the facing surfaces, and then integrating the assembled stack with the other sections required to assemble the final LOE, according to the various examples illustrated herein. Optionally, after assembly of the parts, the major external surfaces are re-polished to ensure mutual parallelism and continuity across the joints. Optionally, a coupling in element, such as a wedge similar to that of Fig. 6 or 7 illustrated above, may be added. It is important to emphasize that the order of the steps presented here is only an example, and that alternative sequences of construction, and alternative construction techniques, also fall within the scope of the present invention.

Turning now to a further set of exemplary embodiments of the present invention, illustrated with reference to FIGS. 14A-16, some display systems employ an LOE which includes two stages of optical expansion within a single waveguide. In such cases, an image projector is coupled to a coupling-in region 30 so as to introduce image illumination corresponding to a collimated image into the LOE so as to propagate within the LOE in a first propagation direction p_1 (FIG. 14B), and a coupling-out configuration associated with a coupling-out region 32 of the LOE and configured for coupling out at least part of the image illumination from the LOE towards the eye of the user. As before, the coupling-out configuration may be a set of mutually-parallel partially reflecting surfaces 16, deployed within the LOE and obliquely oriented relative to the major external surfaces, as illustrated here, and in FIG. 1A, above, or may be

implemented as at least one diffractive optical element, as described above with reference to FIG. 1B.

The device also includes an aperture expansion configuration 34, associated with the LOE and configured to progressively redirect the image illumination from the first propagation direction p_1 so as to propagate within the LOE in a second propagation direction p_2 towards the coupling-out configuration. Here too, the aperture expansion configuration may be based on a plurality of mutually-parallel partially reflecting surfaces 16' deployed within the LOE and obliquely oriented relative to the major external surfaces, as illustrated here, or on one or more diffractive optical element (not shown). In either case, the aperture expansion configuration 34 is differently oriented from the coupling-out configuration so as to achieve expansion along a different in-plane axis.

Certain implementations of the aperture expansion configuration 34 result in redirection of one of the images towards coupling-out region 32 while the conjugate of that image is reflected to an undesired angular orientation, and is effectively lost. For such cases, a symmetrical beam multiplier region 36 is preferably interposed between aperture expansion configuration 34 and coupling-out region 32, so as to compactly reconstruct the image/conjugate pair and fill the waveguide with the image to be coupled out. Structurally, symmetrical beam multiplier region 36 is preferably identical to the beam multiplier structured disclosed above, having n internal planar beam splitters 24, internal to the LOE and parallel to the major external surfaces, subdividing the thickness of the LOE into $(n+1)$ layers of equal thickness.

The symmetrical beam multiplier can thus here be considered a mediating mechanism between several in-plane LOEs, as presented in FIGS. 14A and 14B. As explained above, all beams in the waveguide (LOE) bounce "up" and "down" between the major surfaces due to total internal reflection (TIR). In compound systems where several LOEs (or stages of expansion) are coupled in-plane as a single LOE sharing common major external parallel surfaces. For a reflective aperture expansion arrangement, if the partially-reflective surfaces are not perpendicular to the plane of the LOE, up-going and down-going beams inside the first LOE are reflected at different angles. As a result, only the up-going or down-going rays will eventually be coupled

out to the observer's eye (while the down-going or up-going rays would be considered as unwanted "ghost" images propagating inside the waveguide, that may contaminate the out-coupled signal). However, depending on the facet and field angles, this effect may create "holes" (dark stripes) inside the waveguide, i.e. it may cause partial filling of the entrance aperture of the second LOE, as demonstrated in Fig. 15A (for clarity, only showing rays that reach the eye). To overcome this limitation, the symmetric beam multiplier is placed between the two LOEs, thereby duplicating the present rays (up-going or down-going), such that the entire aperture of the second LOE is filled (FIG. 15B). As before, the size of the mixer should be at least half the aperture size of the most shallow-propagating field in the second LOE.

FIG. 16 illustrates schematically a system employing an image projector POD coupling in directly (typically via a coupling prism, not shown) to the input aperture of a compound waveguide (LOE) with two-stage aperture expansion. This example combines both aspects of the invention described above, including a first mid-plane 50% beam splitter to perform aperture filling that is not achieved directly by the POD coupling in, followed by an aperture expansion configuration 34, implemented using a first set of oblique partially-reflective internal surfaces, to achieve a first dimension of aperture expansion and redirect the image illumination towards a coupling-out region 32. A symmetrical beam multiplier region 36 interposed between aperture expansion configuration 34 and coupling-out region 32 reconstructs the image/conjugate filling of the waveguide, leading to filling uniformity of the image projected towards the eye of the user.

It will be appreciated that the display includes various additional components, typically including a controller for actuating the image projector, typically employing electrical power from a small onboard battery or some other suitable power source. It will be appreciated that the controller includes all necessary electronic components such as at least one processor or processing circuitry to drive the image projector, all as is known in the art. These features are not part of the invention per se, and therefore will not be described here in detail. All such features will be readily implemented by a person ordinarily skilled in the art.

It will be appreciated that the above descriptions are intended only to serve as examples, and that many other embodiments are possible within the scope of the present invention as defined in the appended claims.

WHAT IS CLAIMED IS:

1. An optical system for displaying an image to an eye of a user comprising:
- 5 (a) a light-guide optical element (LOE) having two planar major external surfaces that are parallel so as to support propagation of image illumination within the LOE by internal reflection at the major external surfaces;
 - (b) a coupling-out configuration deployed at a coupling-out region of the LOE and configured for coupling out at least part of the image illumination from the LOE towards the eye of the user; and
 - 10 (c) an image projector for generating image illumination corresponding to a collimated image, the image projector being optically coupled to the LOE so as to introduce the image illumination into the LOE so as to propagate within the LOE by internal reflection,

wherein the LOE further comprises a beam multiplier region, distinct from the coupling-out
15 region, the beam multiplier region having n internal planar beam splitters, where n is an integer greater than 1, each beam splitter being internal to the LOE and parallel to the major external surfaces, the n beam splitters subdividing a thickness of the LOE between the major external surfaces into $(n+1)$ layers of equal thickness, each beam splitter having a reflectivity for image illumination propagating within the LOE by internal reflection given by $1/(i+1)$
20 where i is an index for sequential beam splitters for i from 1 to n .

2. The optical system of claim 1, wherein the coupling-out configuration comprises a plurality of mutually-parallel partially reflecting surfaces deployed within the LOE and obliquely oriented relative to the major external surfaces.

25

3. The optical system of any one of claims 1-2, wherein the coupling-out configuration comprises at least one diffractive optical element deployed at the coupling-out region of the LOE and configured for progressively coupling out a part of the image illumination towards the eye of the user.

FIG. 1B

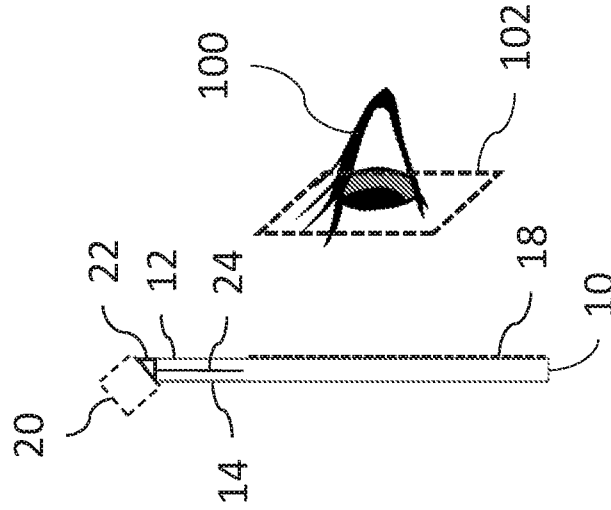
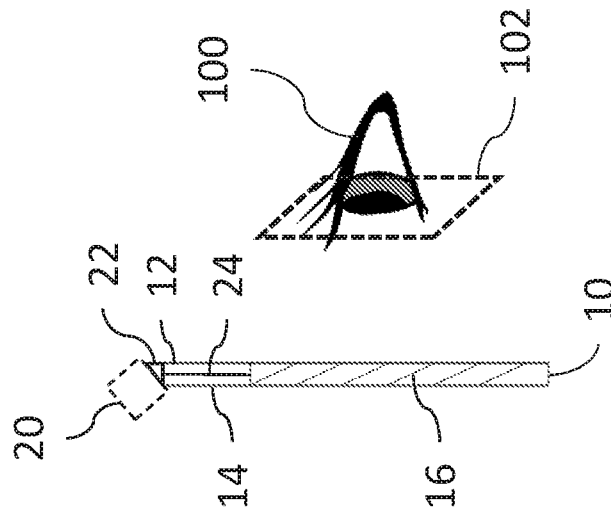

FIG. 1A



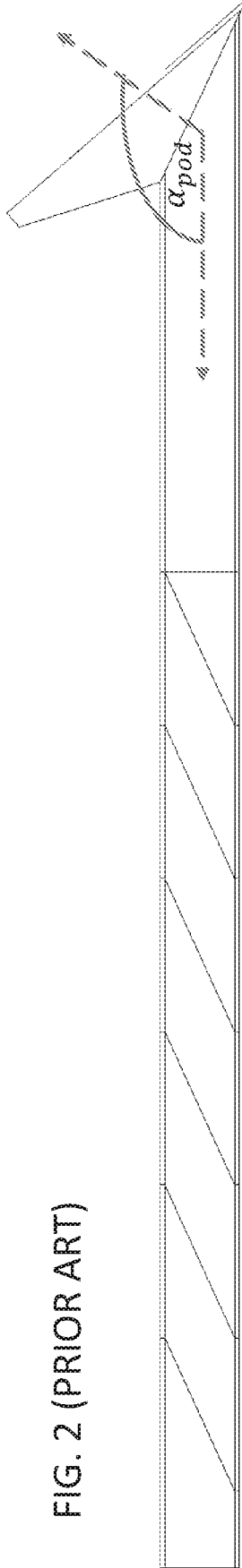

FIG. 2 (PRIOR ART)

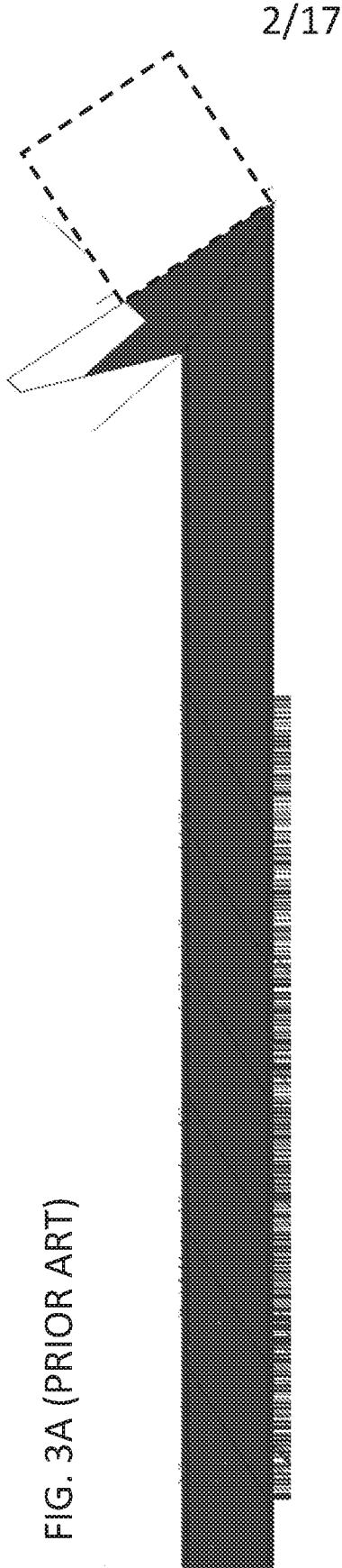

FIG. 3A (PRIOR ART)

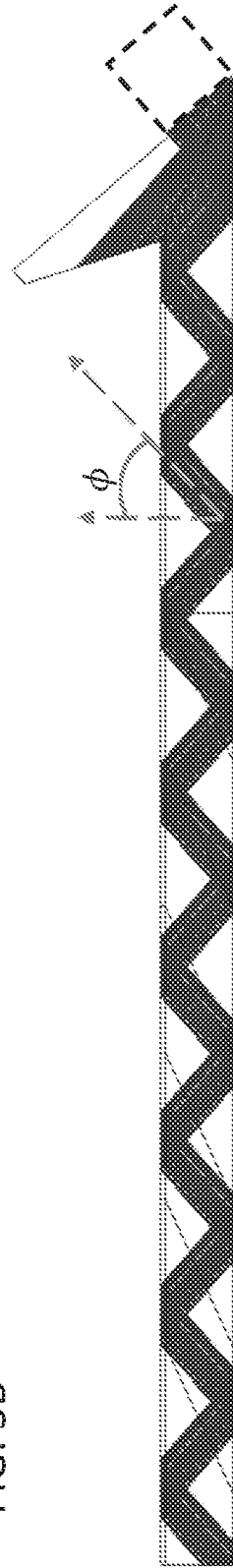

FIG. 3B

FIG. 4A

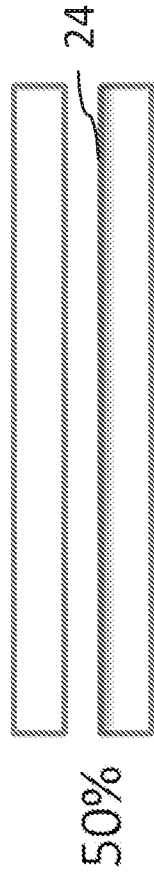
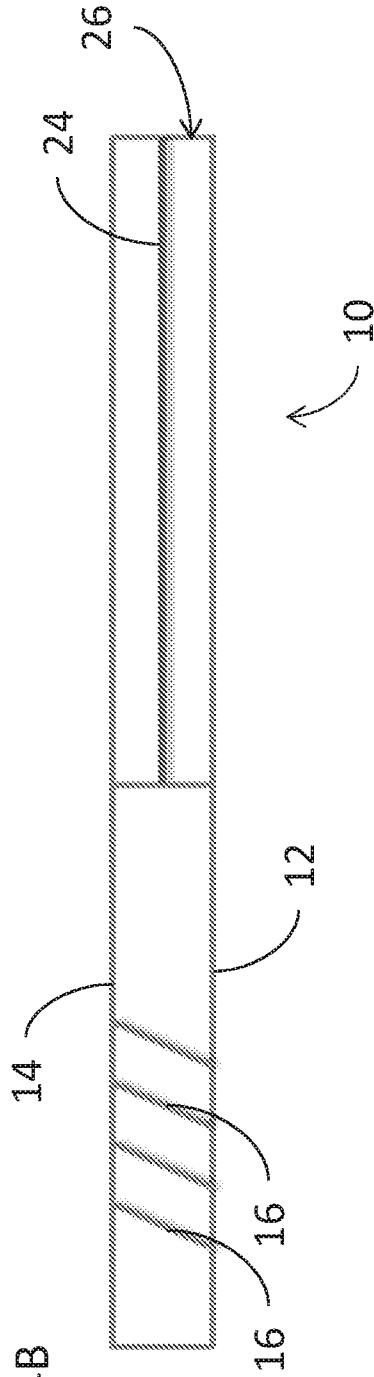

FIG. 4B



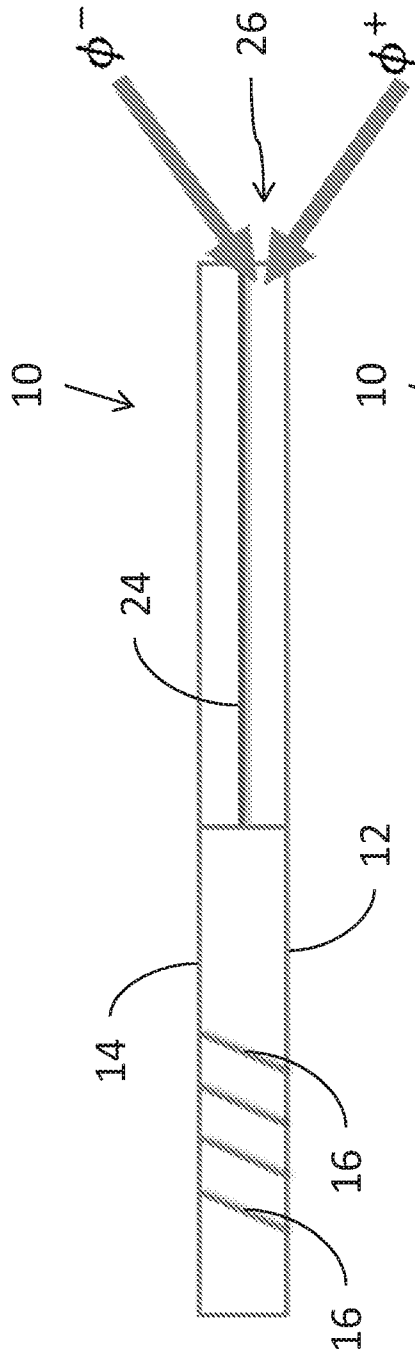

FIG. 5A

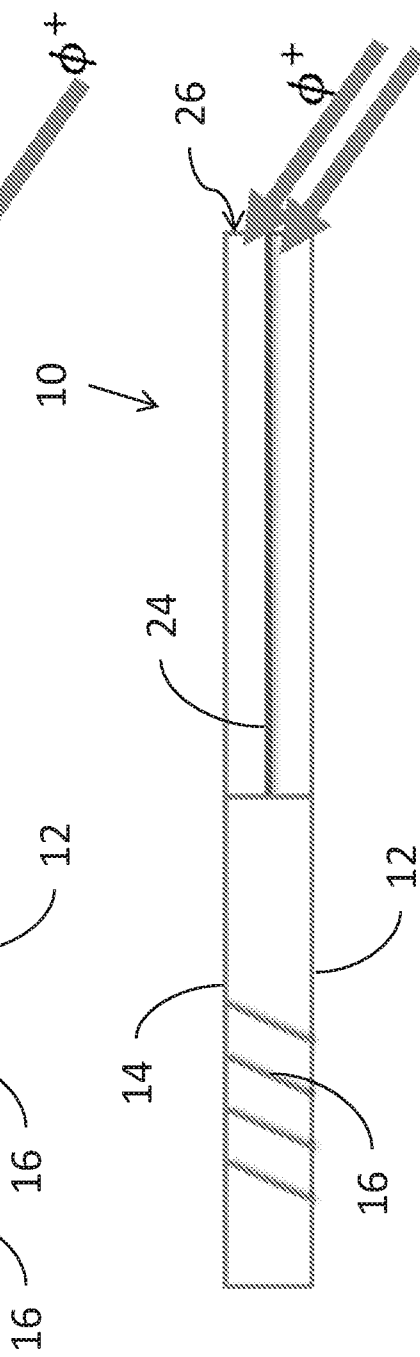

FIG. 5B

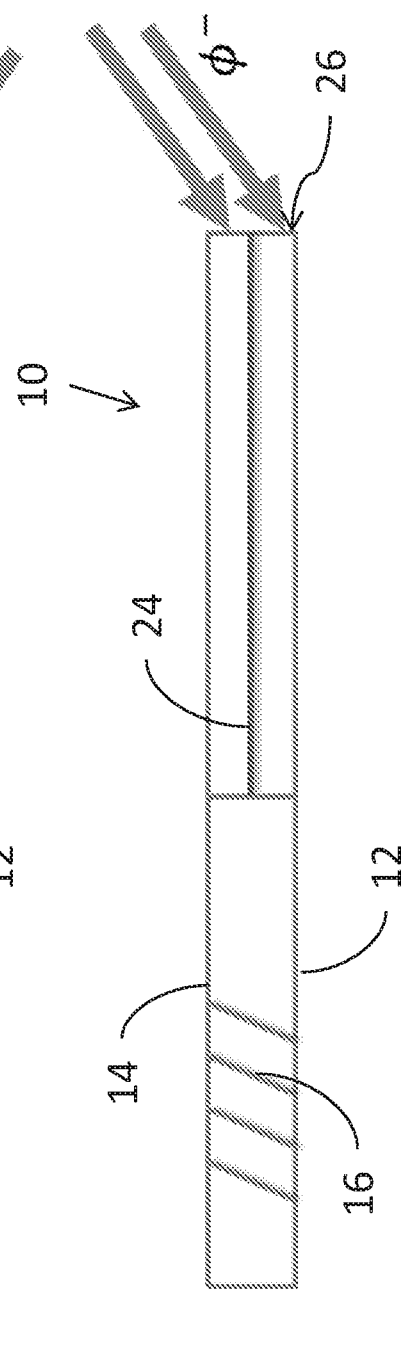

FIG. 5C

FIG. 6

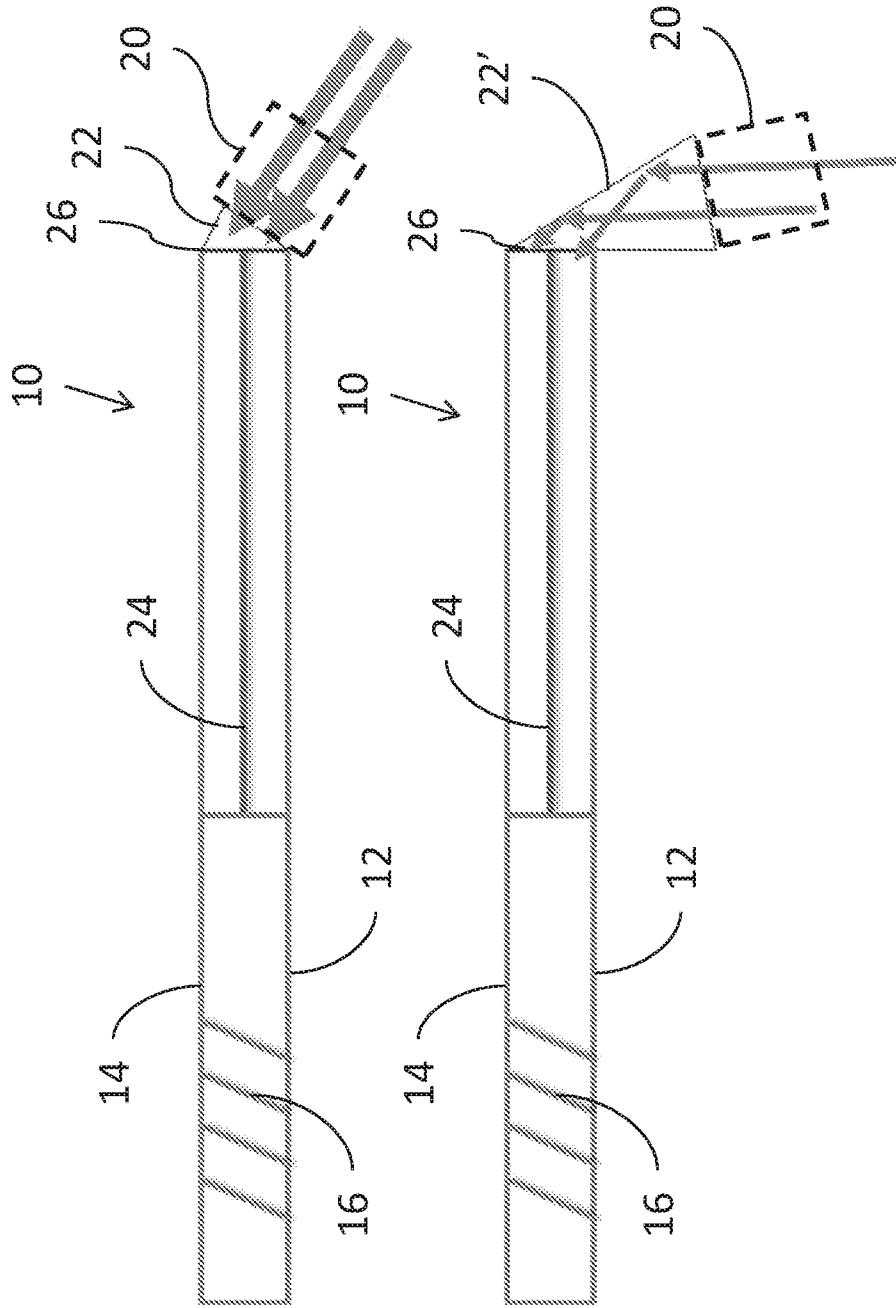
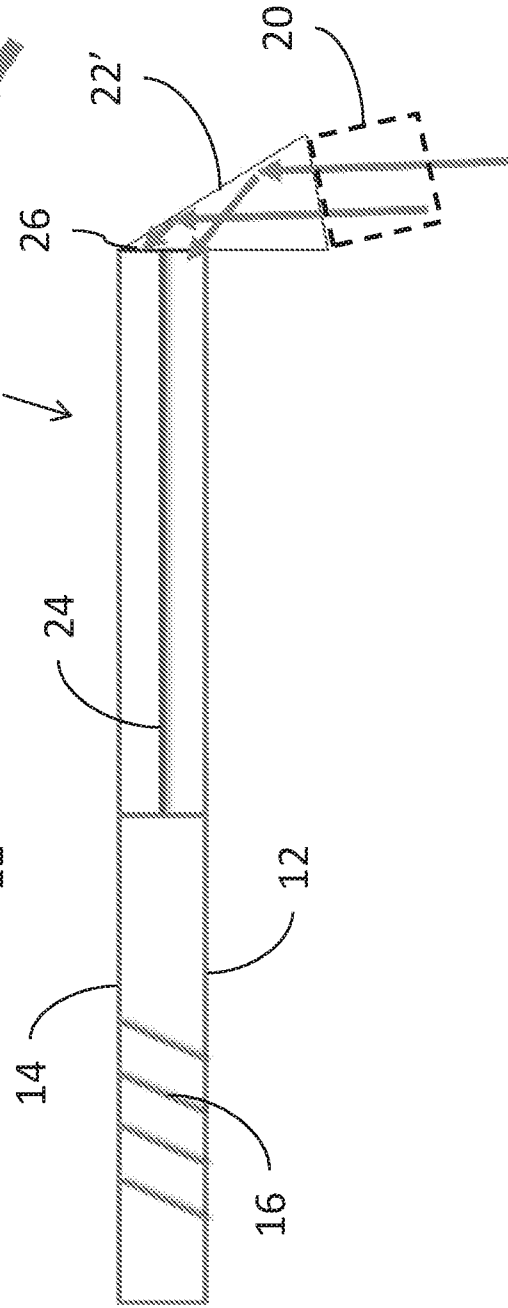

FIG. 7



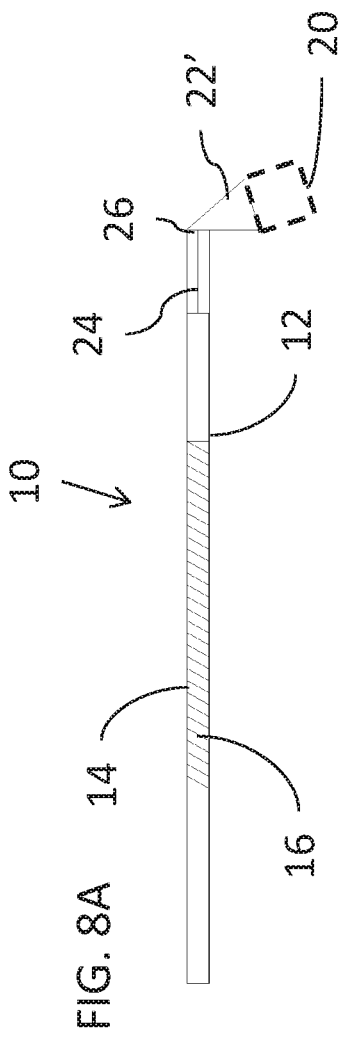

FIG. 8A

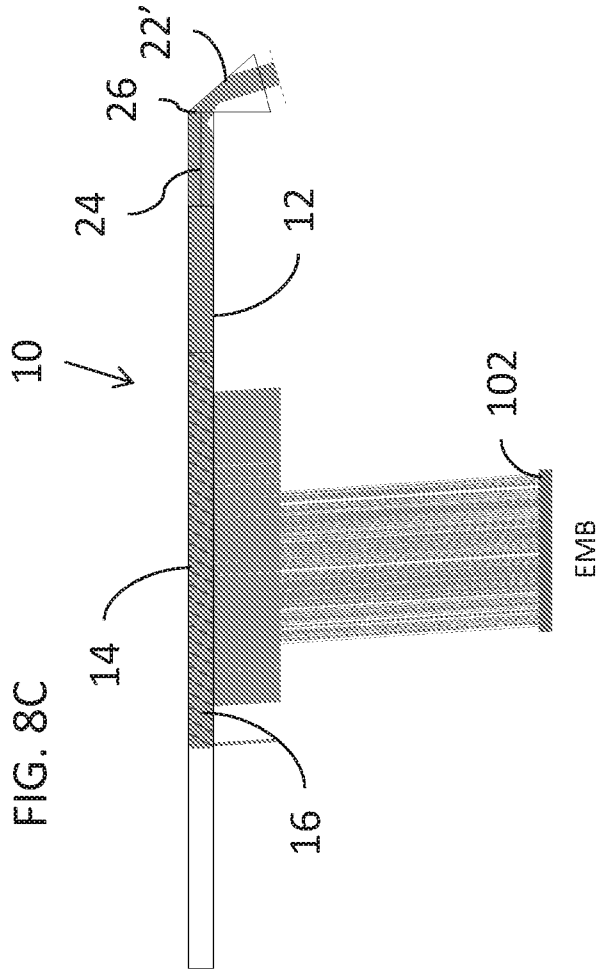

FIG. 8C

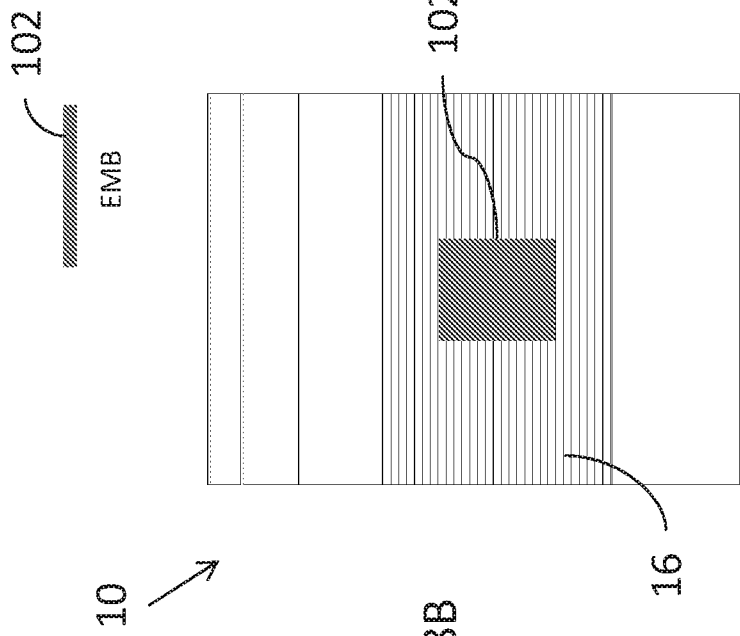
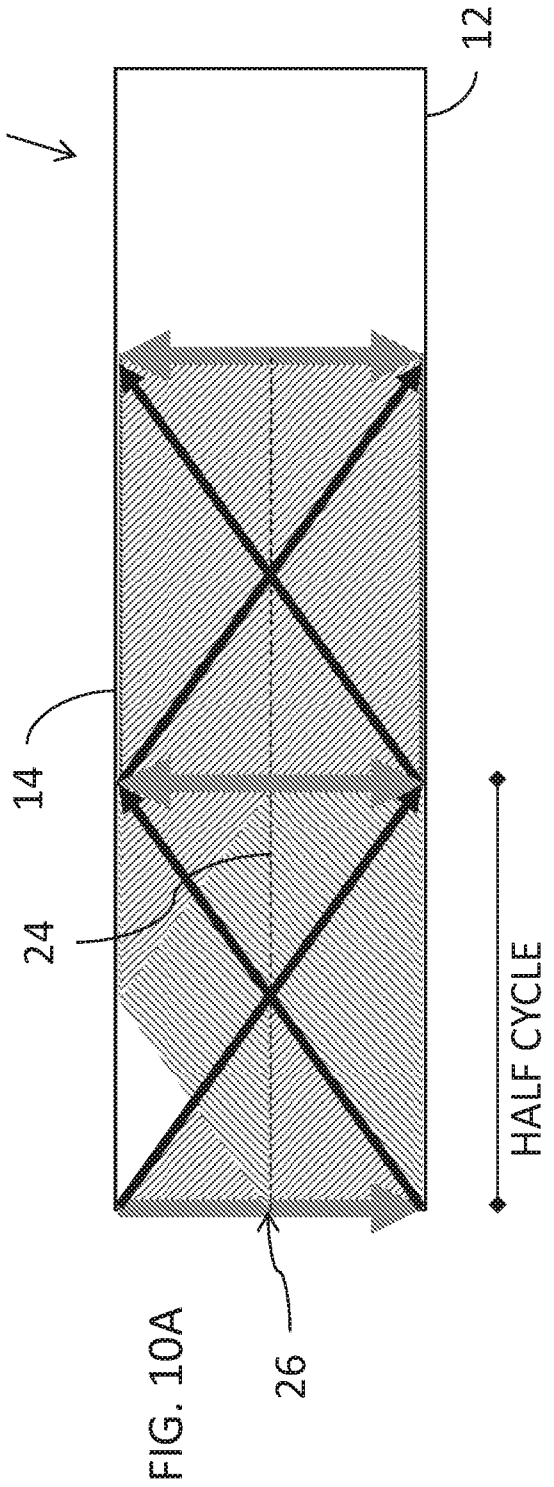
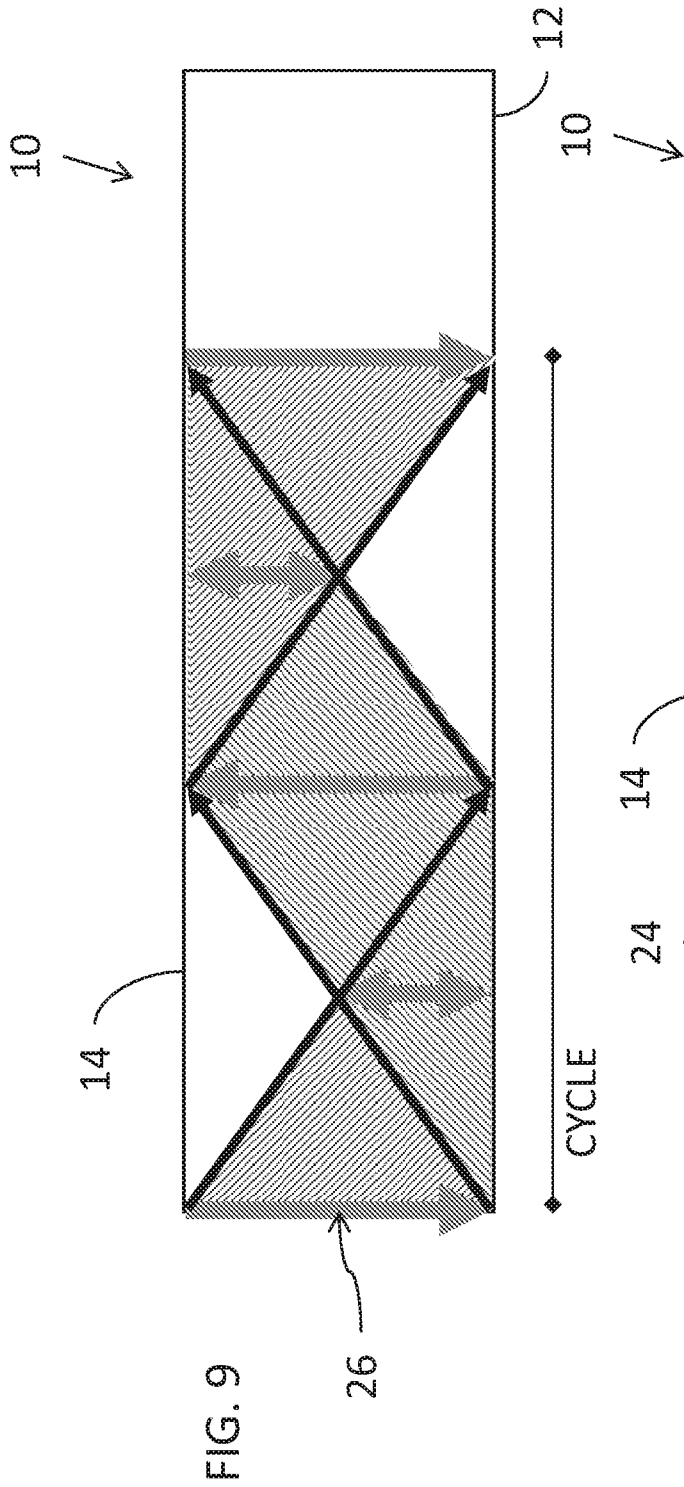

FIG. 8B



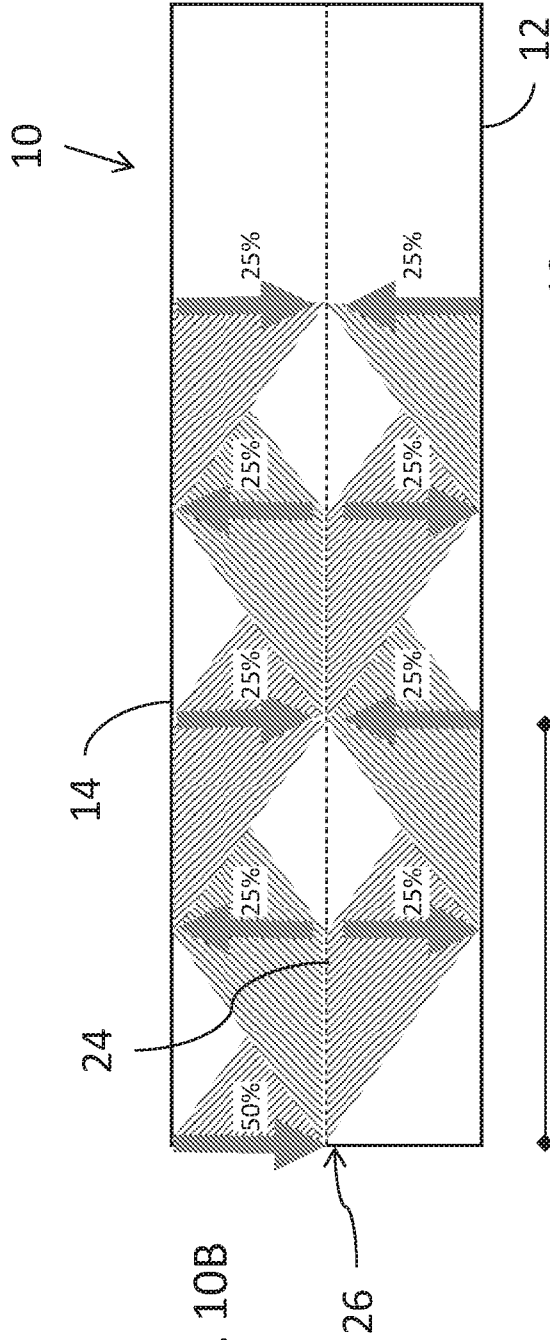

FIG. 10B

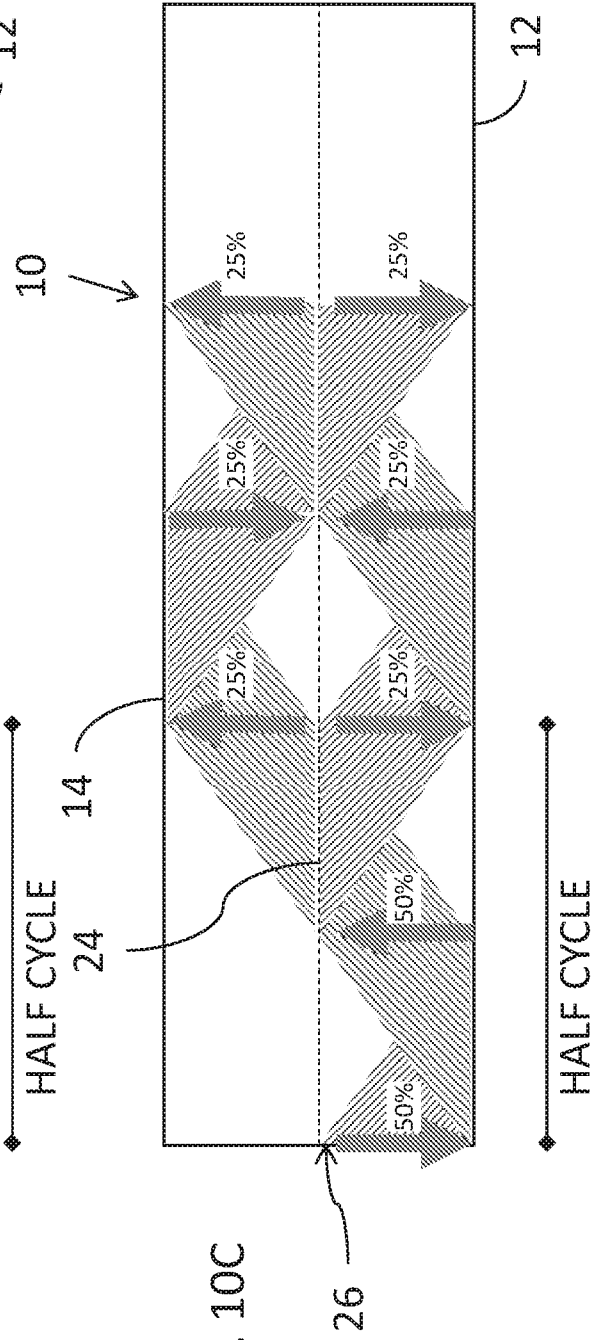
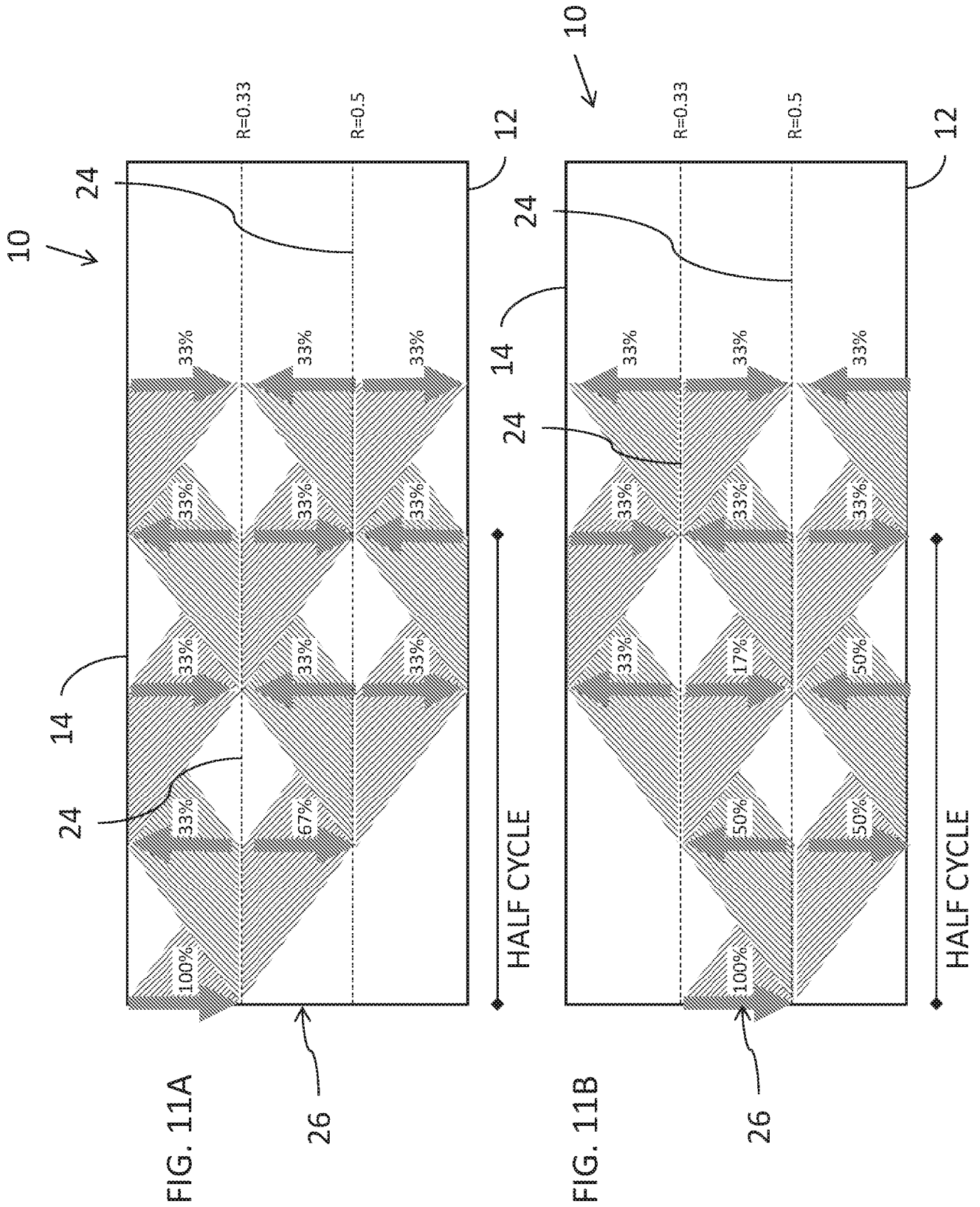
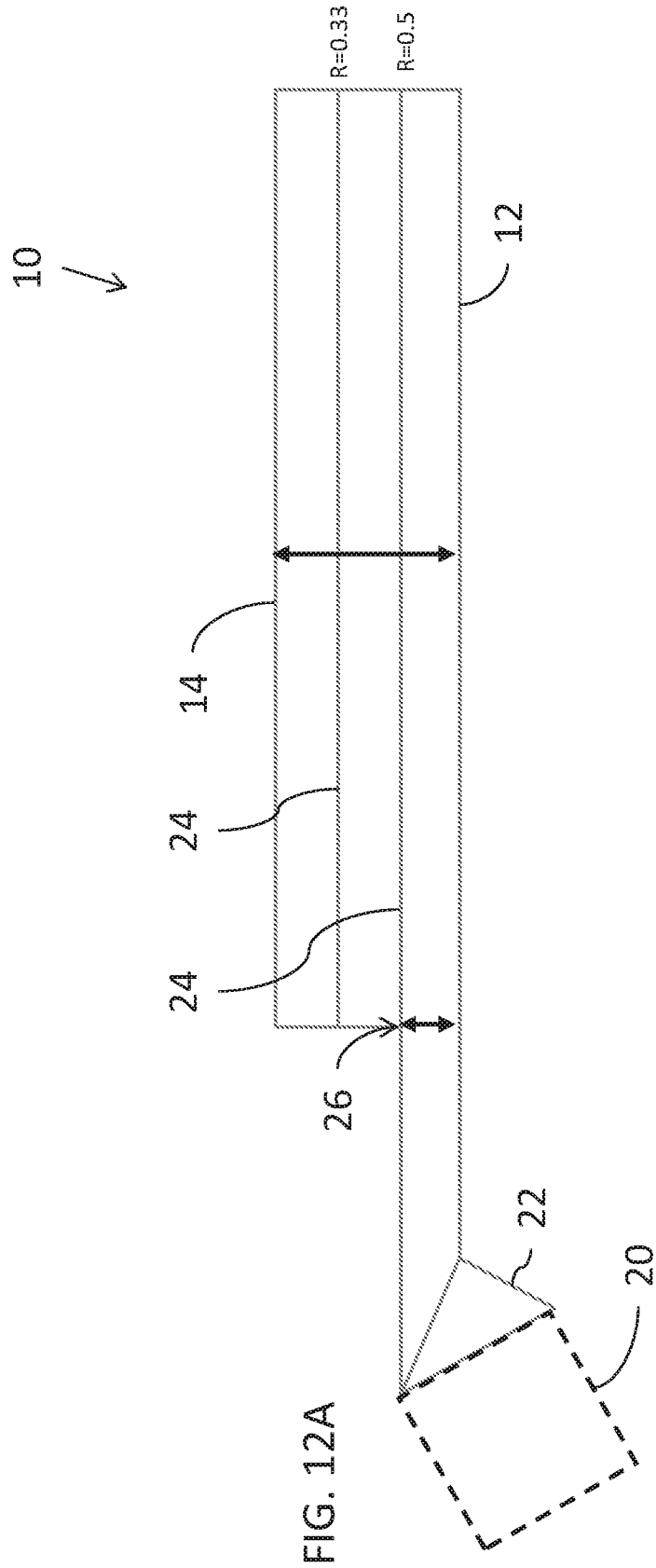
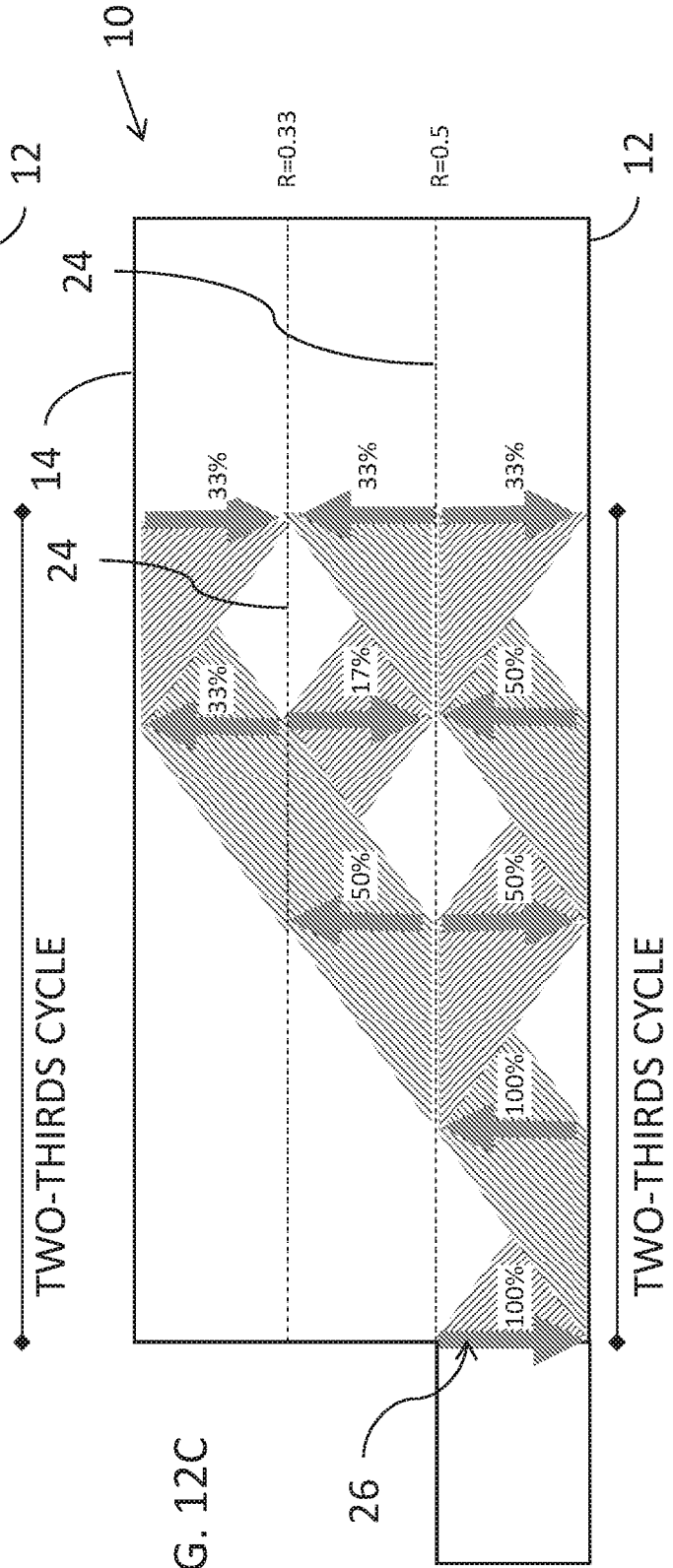
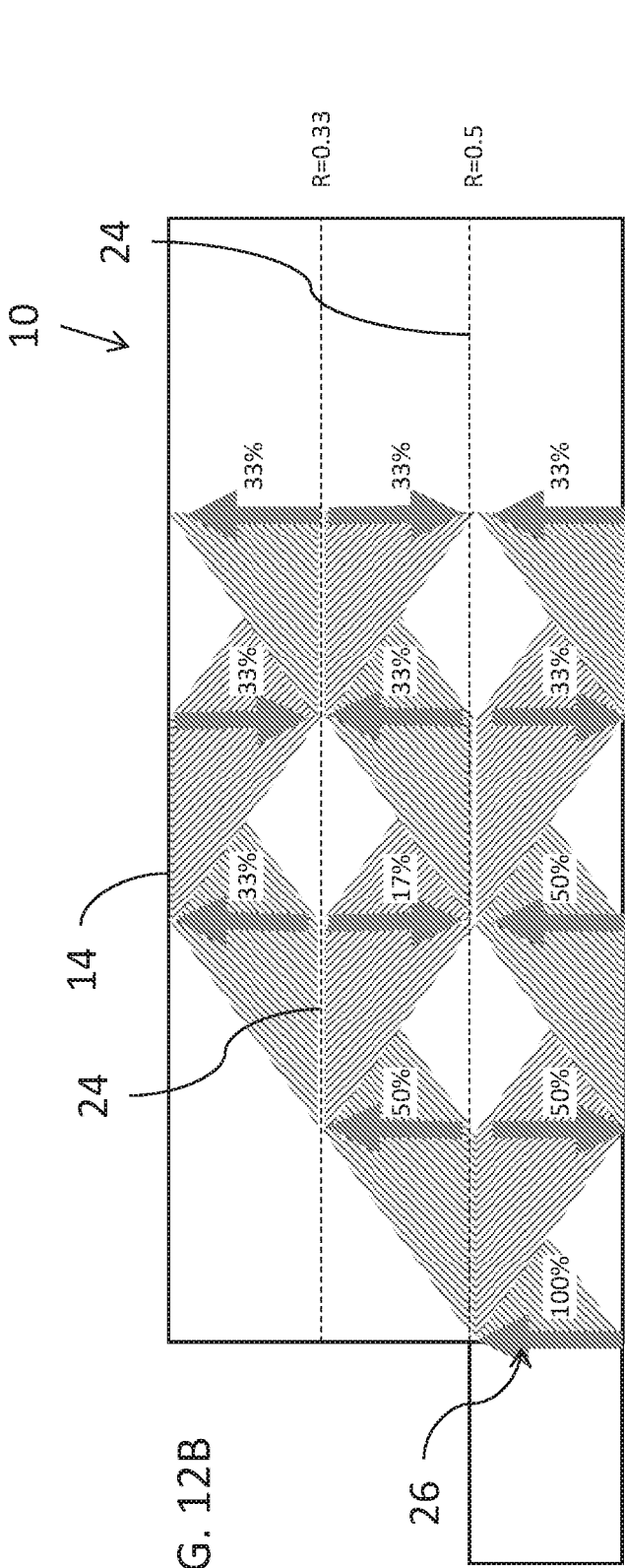
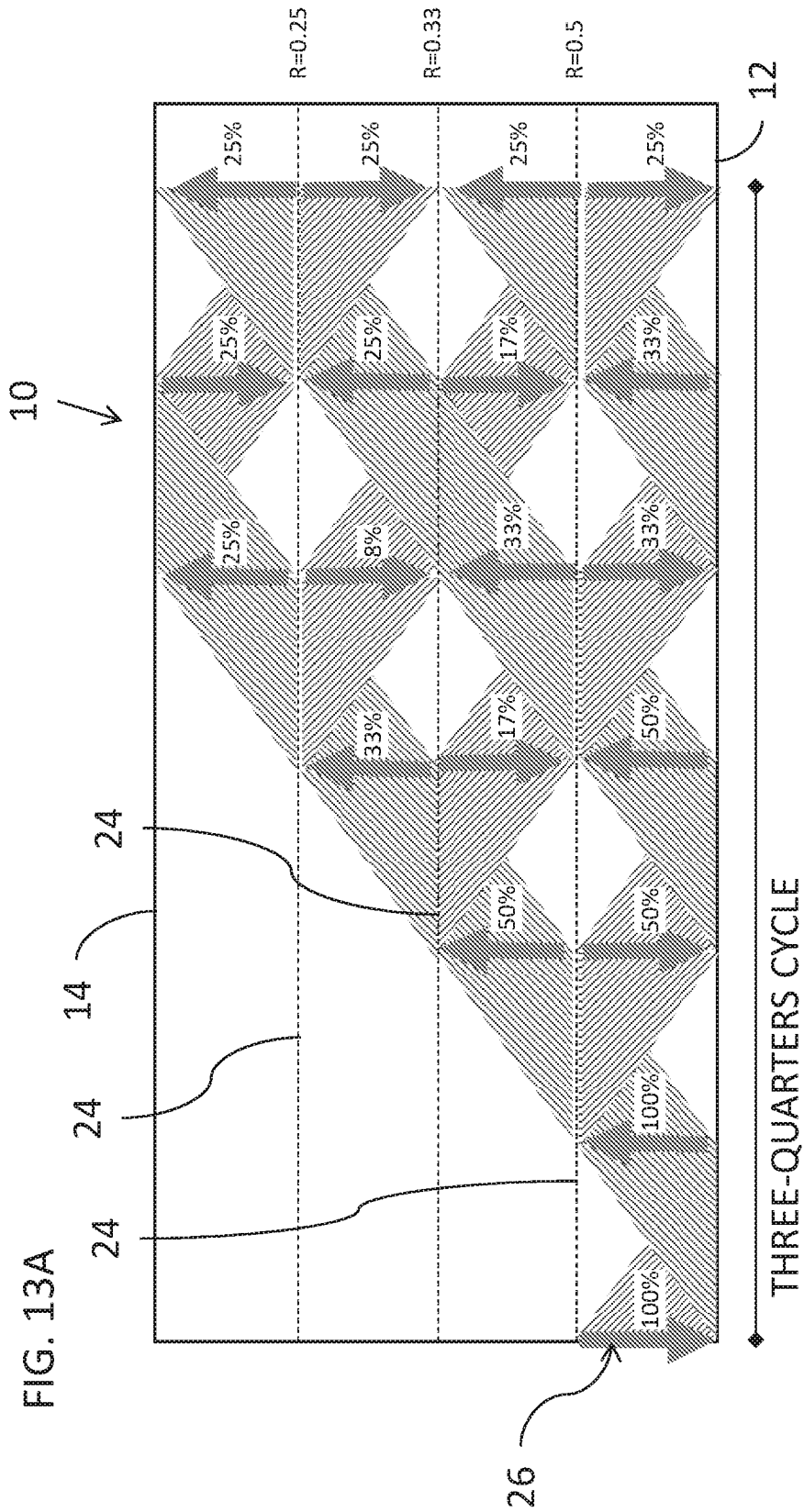

FIG. 10C









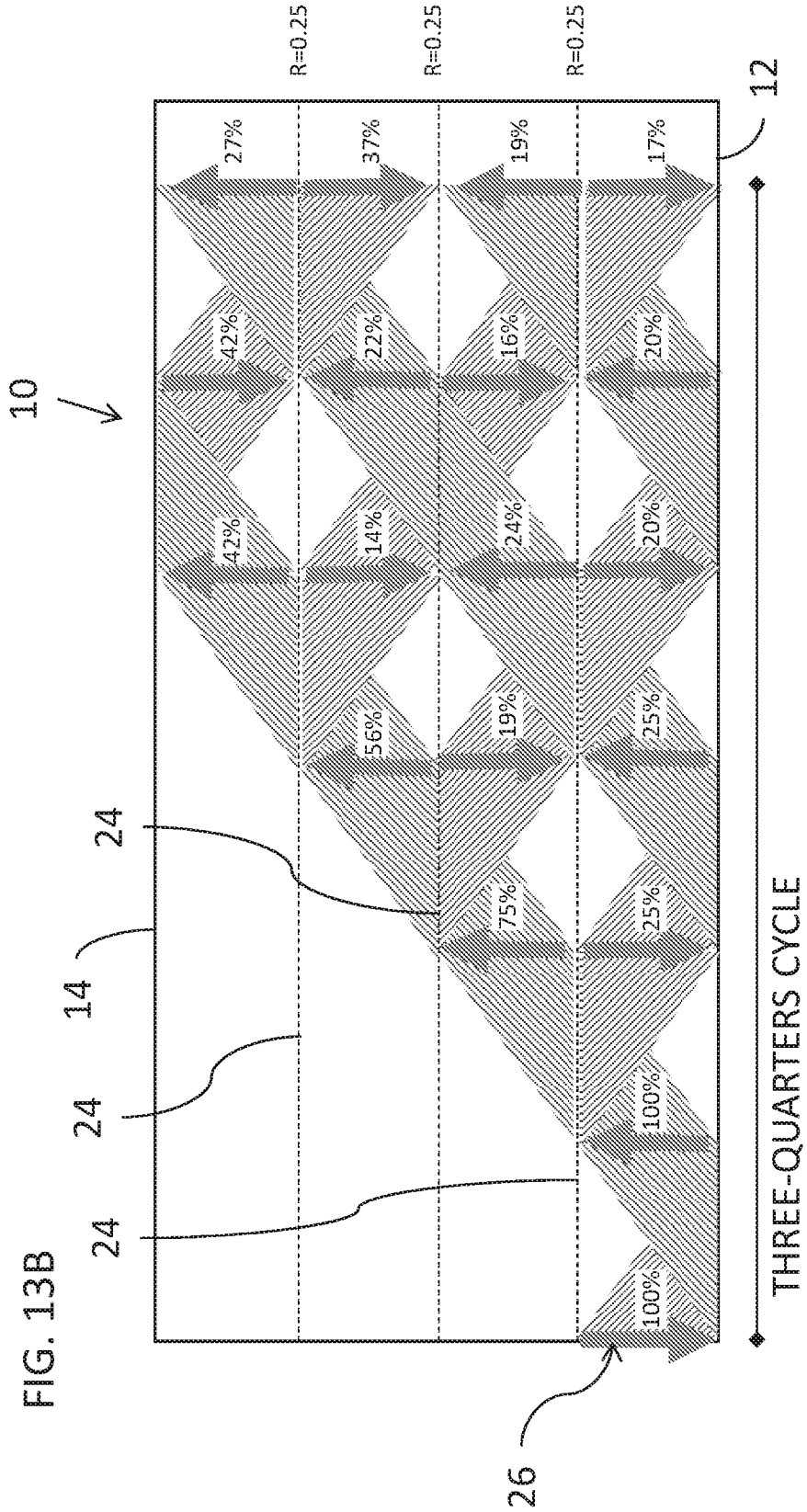
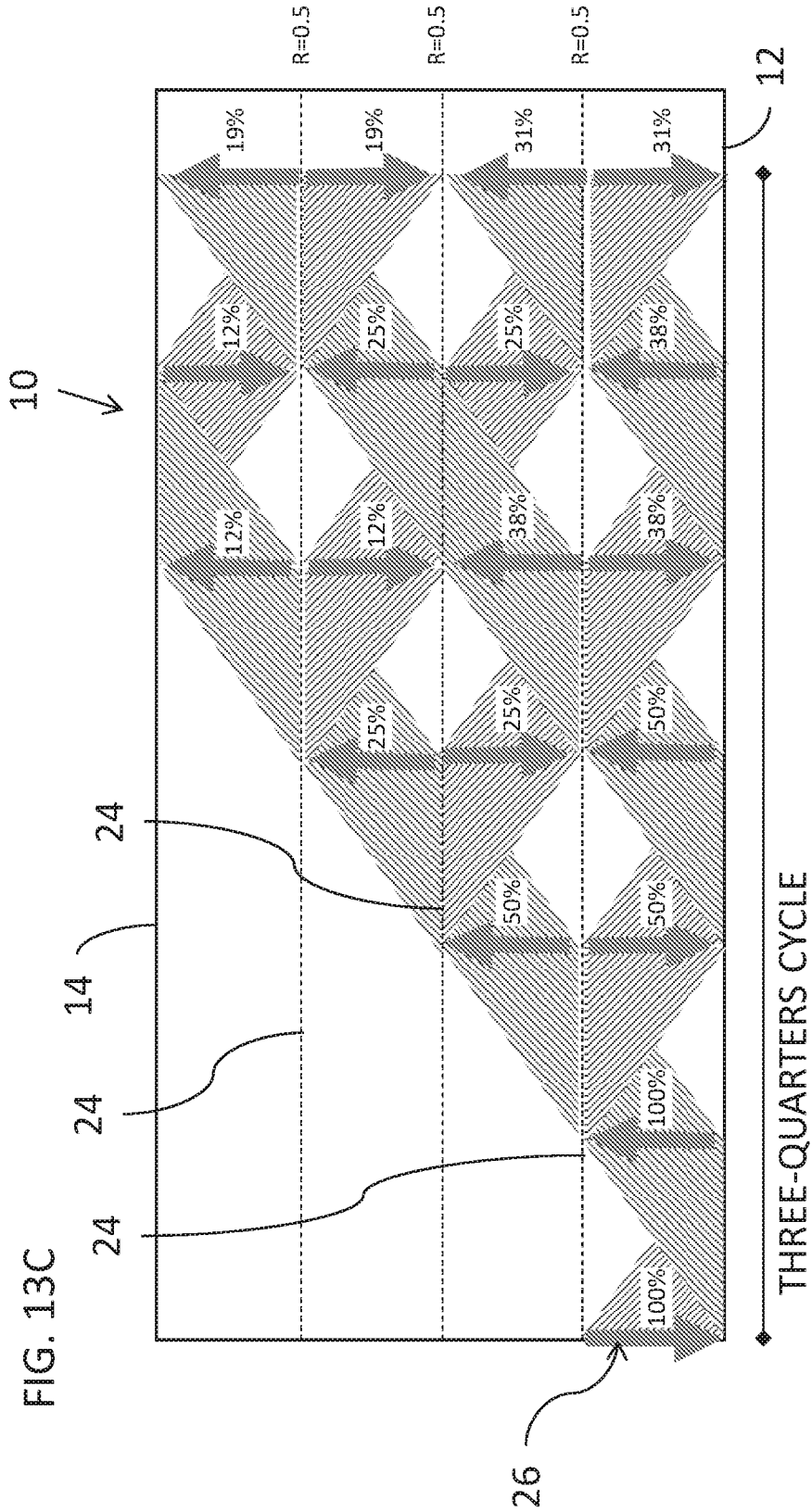
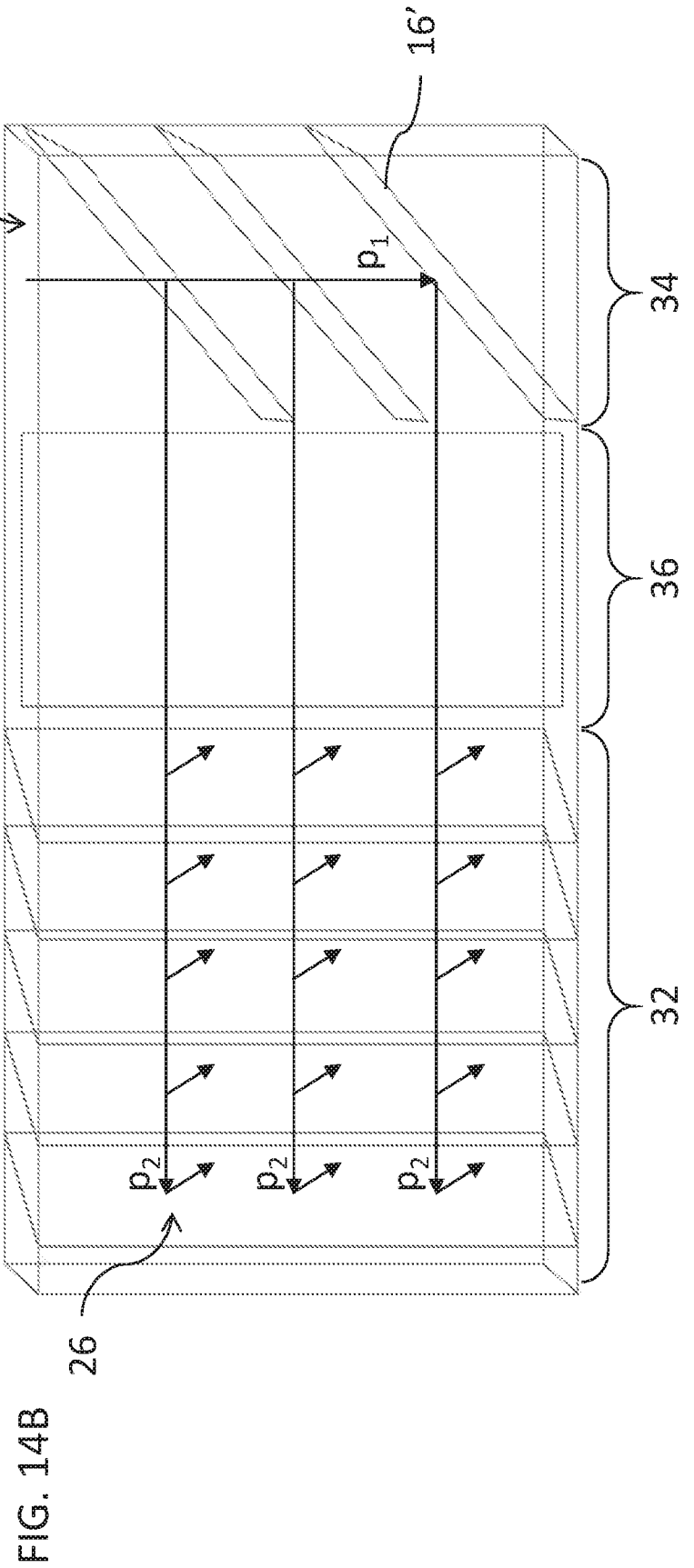
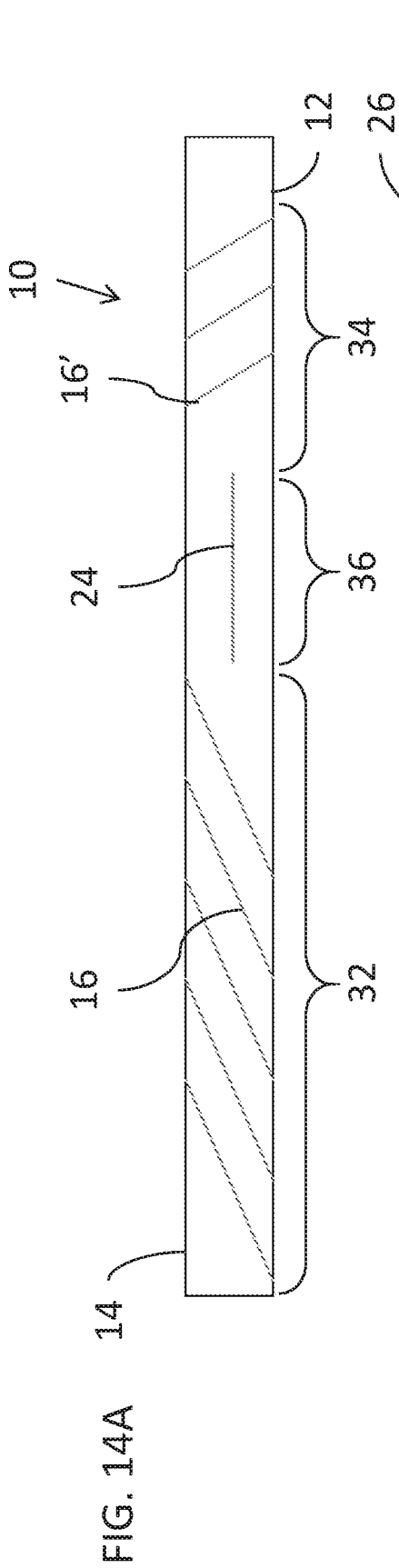

FIG. 13B





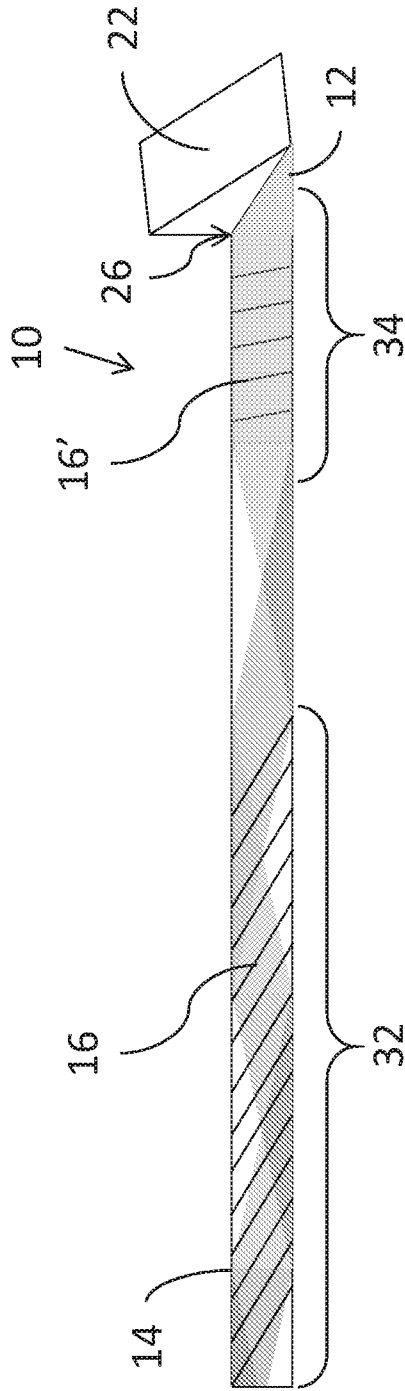

FIG. 15A

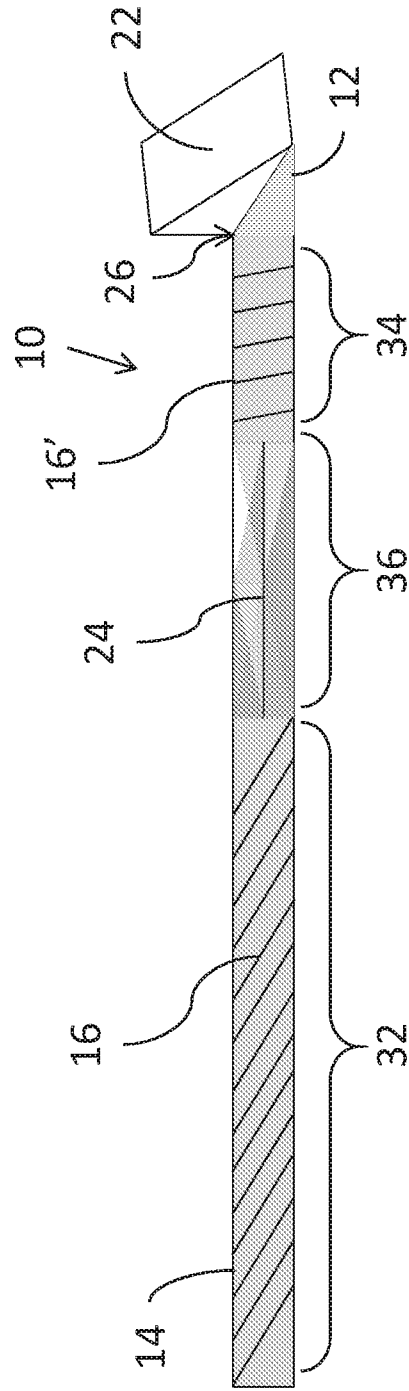

FIG. 15B

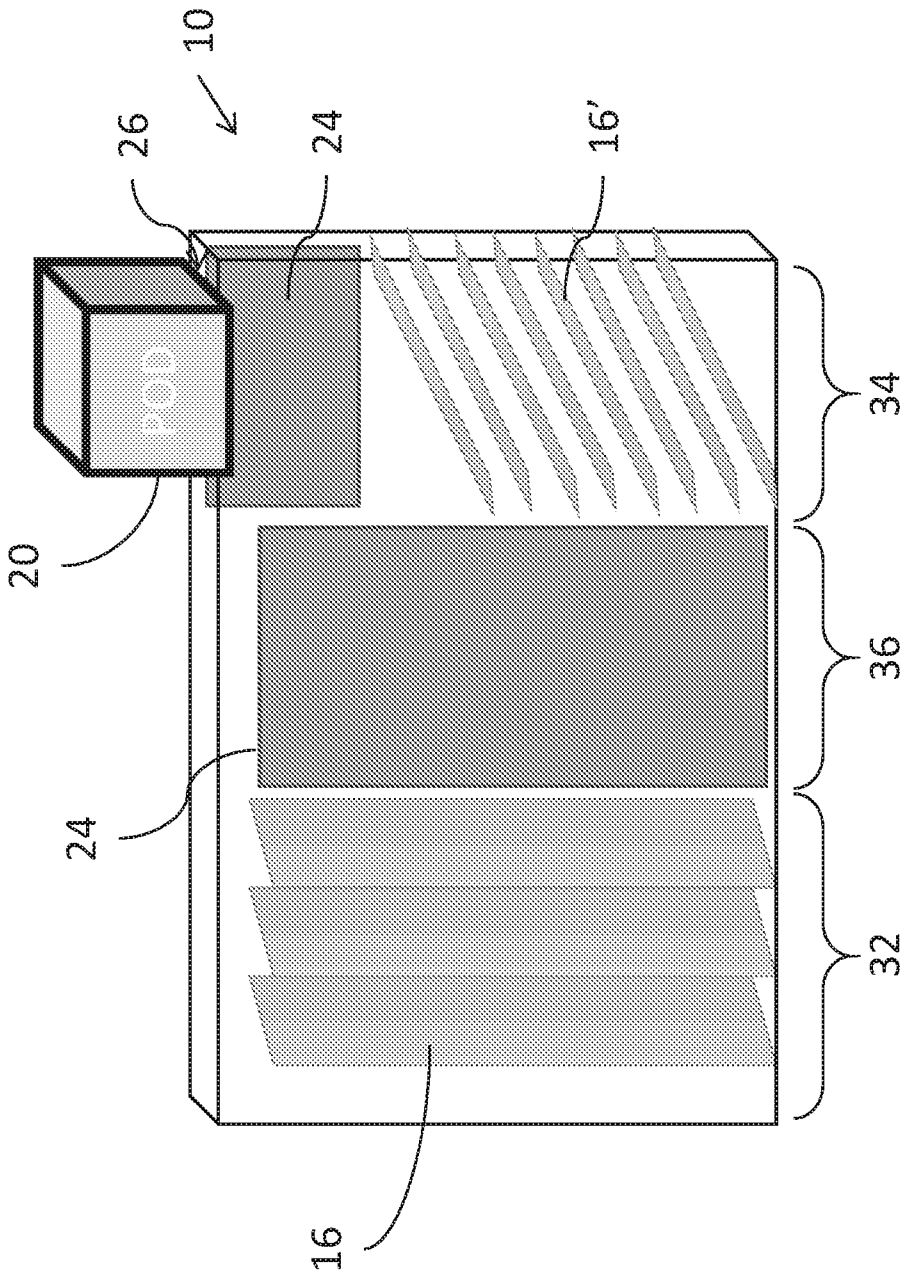

FIG. 16

