



US00D785503S

(12) **United States Design Patent**  
**Qu**

(10) **Patent No.:** **US D785,503 S**

(45) **Date of Patent:** **\*\* May 2, 2017**

(54) **CAR BODY**

(71) Applicant: **Wenjun Qu**, Los Angeles, CA (US)

(72) Inventor: **Wenjun Qu**, Los Angeles, CA (US)

(\*\*) Term: **15 Years**

(21) Appl. No.: **29/539,563**

(22) Filed: **Sep. 15, 2015**

(51) **LOC (10) Cl.** ..... **12-08**

(52) **U.S. Cl.**  
USPC ..... **D12/88**

(58) **Field of Classification Search**  
USPC ..... D12/86, 90-92, 88; D21/421, 433, 434;  
296/181.1, 181.5  
CPC ..... B62D 35/00; B62D 25/00; B62D 25/06;  
B62D 33/00  
See application file for complete search history.

(56) **References Cited**

**U.S. PATENT DOCUMENTS**

D305,250 S	12/1989	Vendetti	
D469,387 S *	1/2003	Ramaciotti	D12/88
D469,826 S	2/2003	Prewitt	
D491,843 S *	6/2004	Giugiaro	D12/88
D550,124 S *	9/2007	Agullo Spottorno	D12/88
D550,126 S *	9/2007	Amprimo	D12/88
D710,259 S *	8/2014	Baccino	D12/92
D715,690 S *	10/2014	Perini	D12/88
D718,667 S *	12/2014	Manzoni	D12/92
D734,212 S *	7/2015	Stephenson	D12/92

D734,213 S *	7/2015	Stephenson	D12/92
D739,789 S *	9/2015	Payne	D12/92
D741,753 S *	10/2015	Perini	D12/92
D753,549 S *	4/2016	Manzoni	D12/88

\* cited by examiner

*Primary Examiner* — Melody N Brown

(74) *Attorney, Agent, or Firm* — Martine Penilla Group, LLP

(57) **CLAIM**

The ornamental design for a car body, as shown and described.

**DESCRIPTION**

FIG. 1 is a top and front perspective view of a car body showing my new design;  
 FIG. 2 is a front elevational view thereof;  
 FIG. 3 is a rear elevational view thereof;  
 FIG. 4 is a side elevational view thereof;  
 FIG. 5 is an opposite side elevational view thereof;  
 FIG. 6 is a top perspective view thereof;  
 FIG. 7 is an opposite side and rear perspective view thereof;  
 FIG. 8 is a top and front perspective view of a second embodiment of car body showing my new design;  
 FIG. 9 is a front elevational view of FIG. 8;  
 FIG. 10 is a rear elevational view of FIG. 8;  
 FIG. 11 is a side elevational view of FIG. 8;  
 FIG. 12 is an opposite side elevational view of FIG. 8;  
 FIG. 13 is a top perspective view of FIG. 8; and  
 FIG. 14 is an opposite side and rear perspective view of FIG. 8.

The broken lines form no part of the claimed design.

**1 Claim, 12 Drawing Sheets**

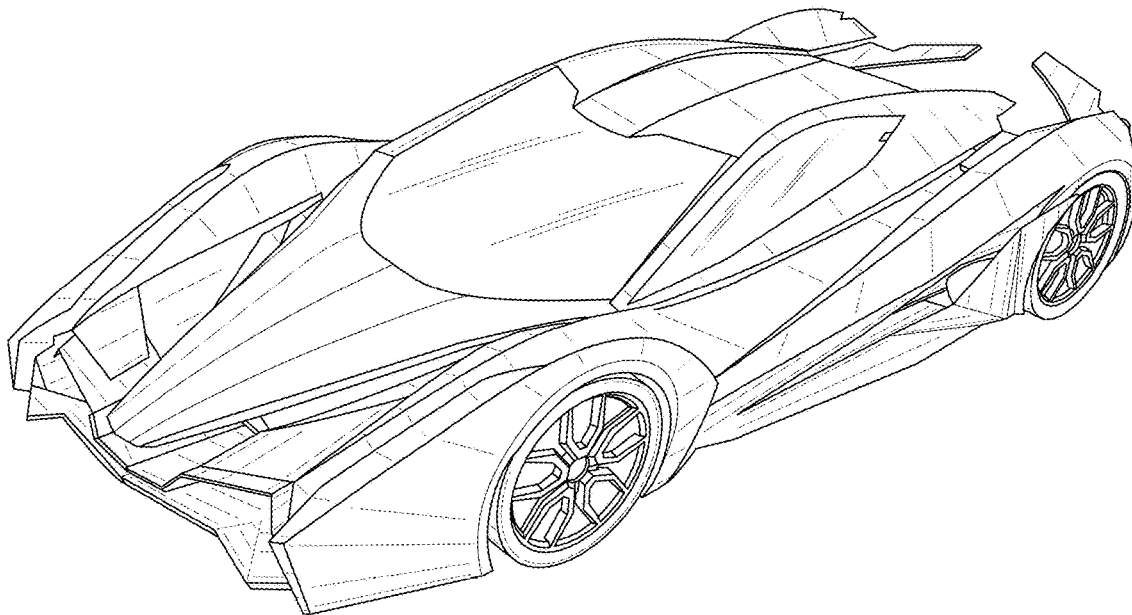

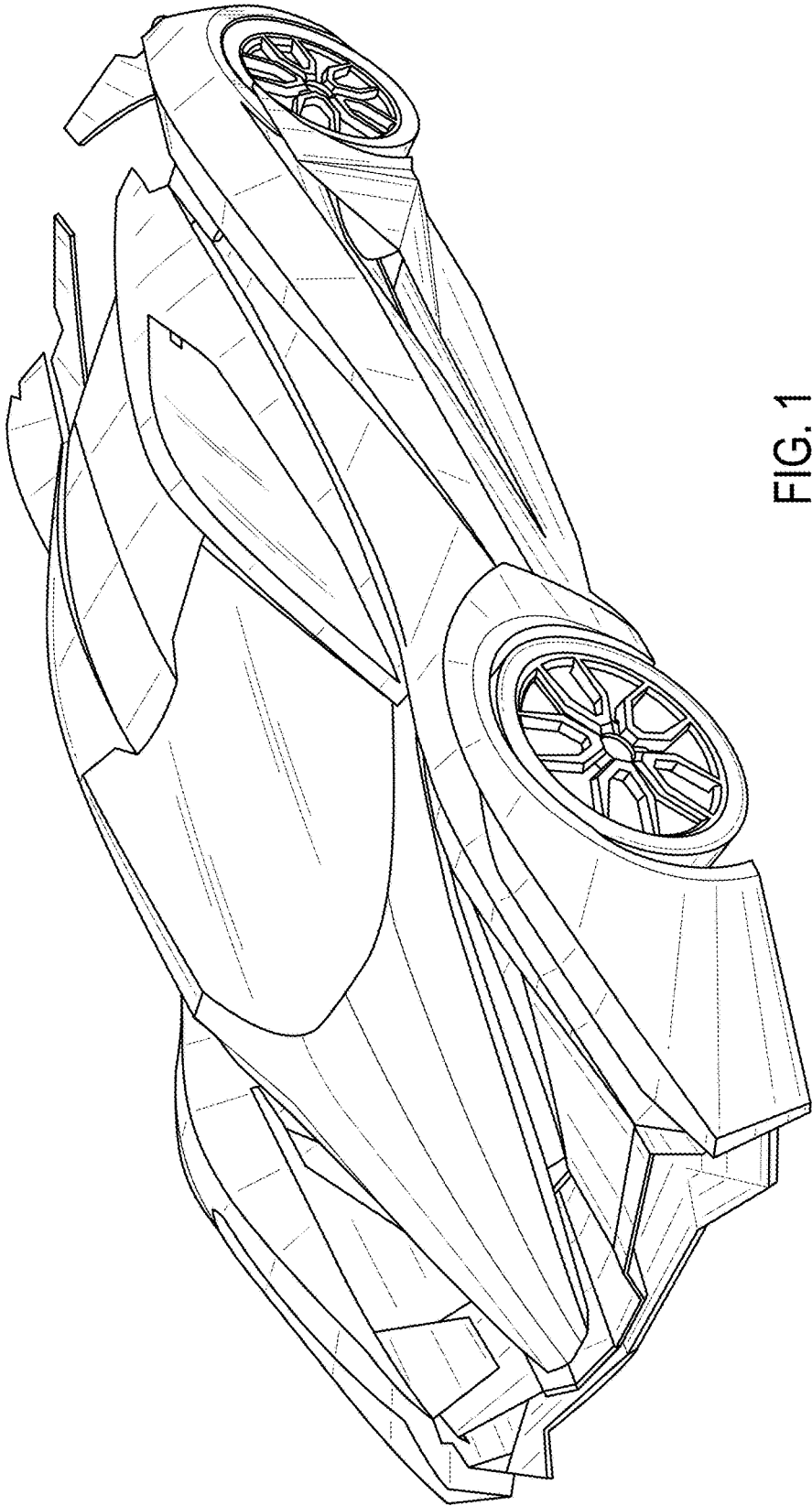

FIG. 1

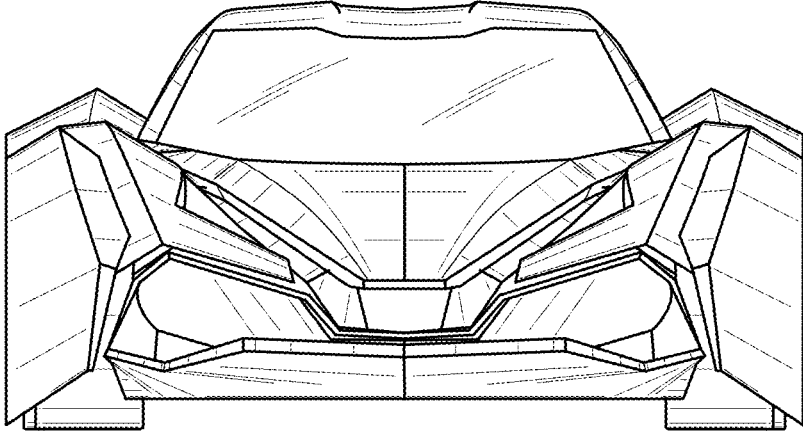

FIG. 2

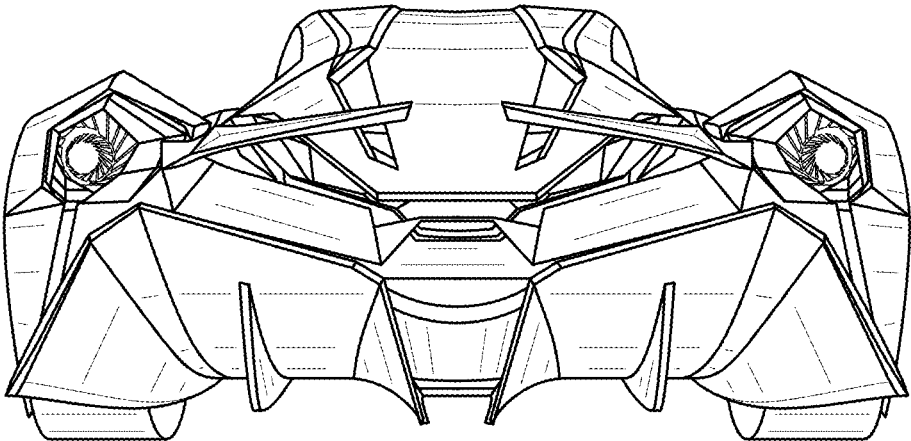

FIG. 3



FIG. 4



FIG. 5

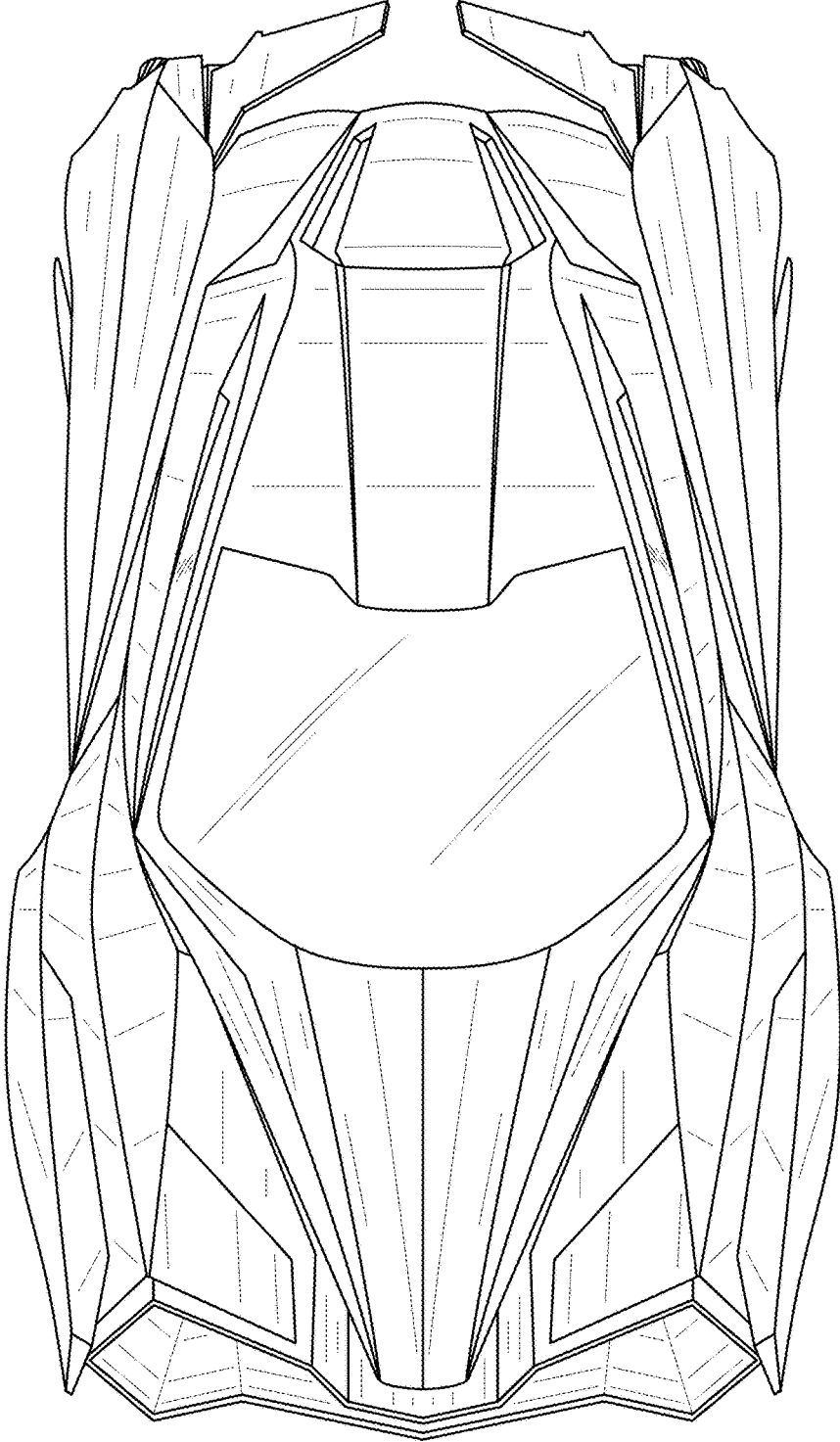

FIG. 6

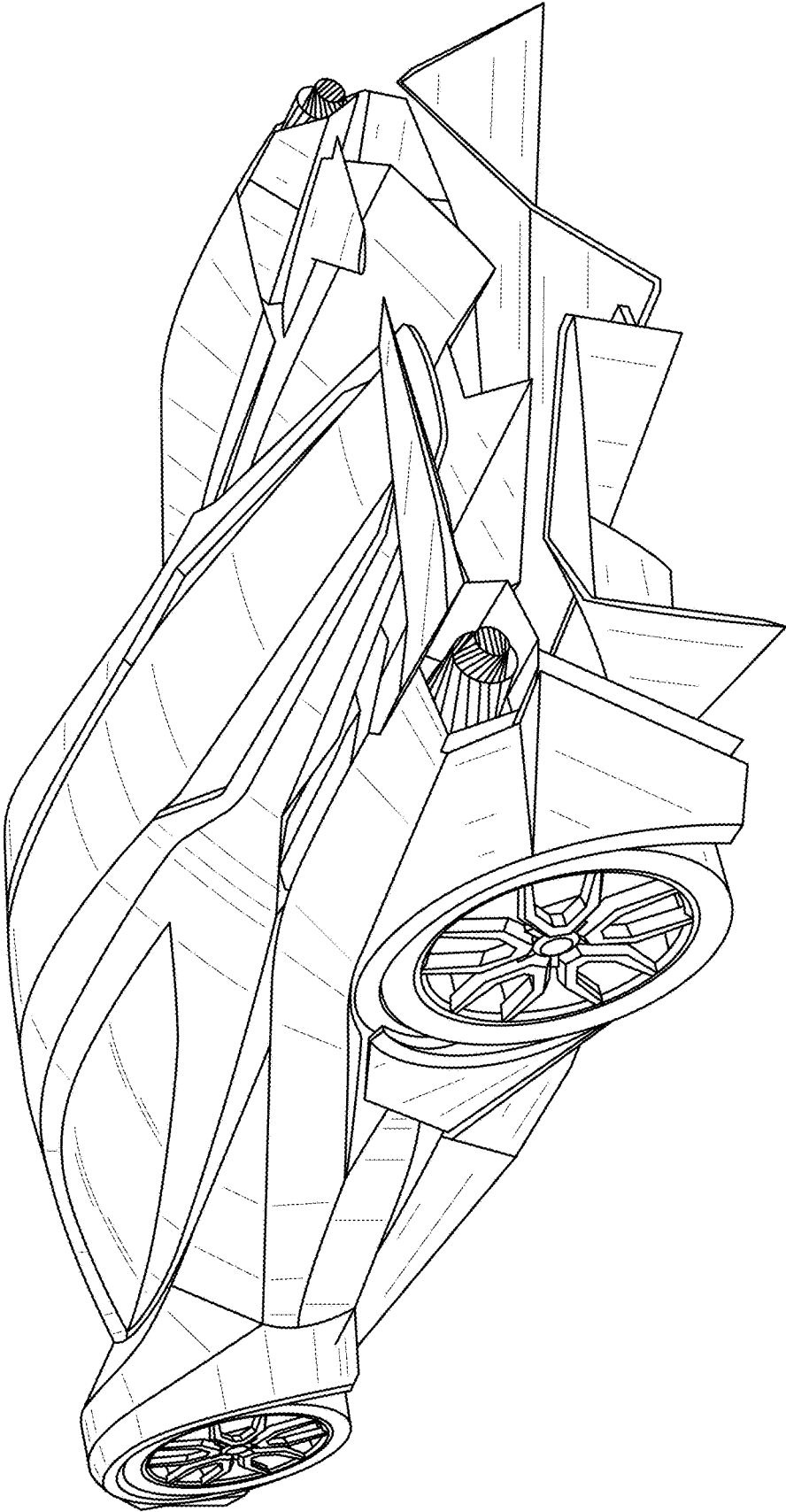

FIG. 7

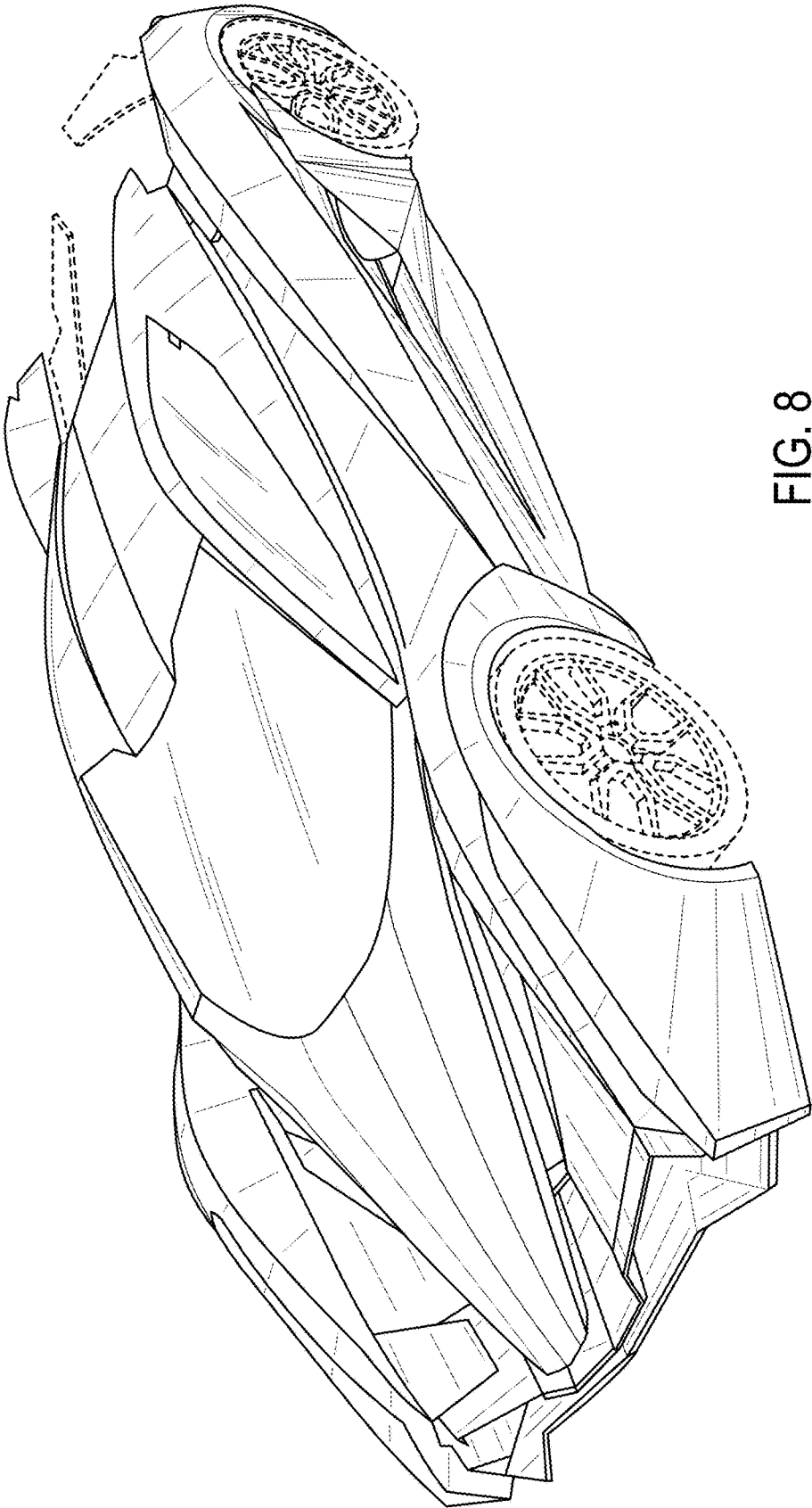

FIG. 8



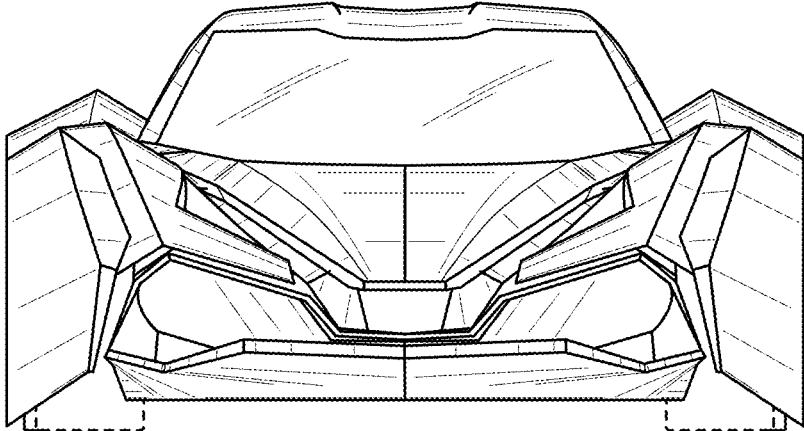

FIG. 9

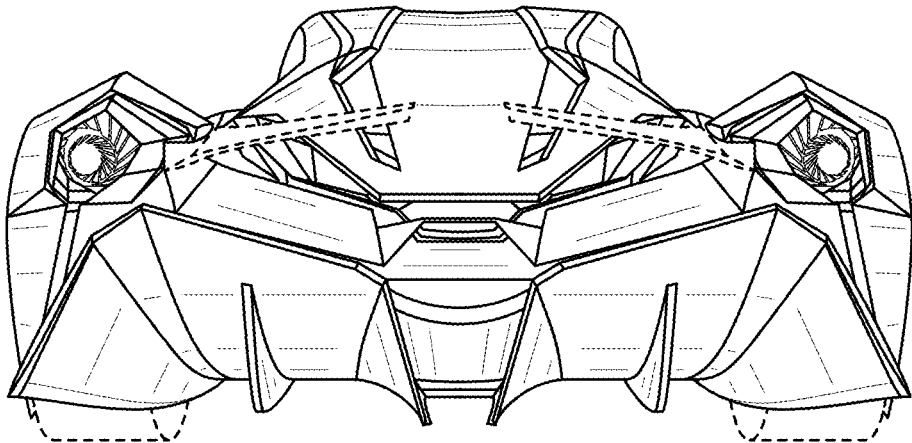

FIG. 10

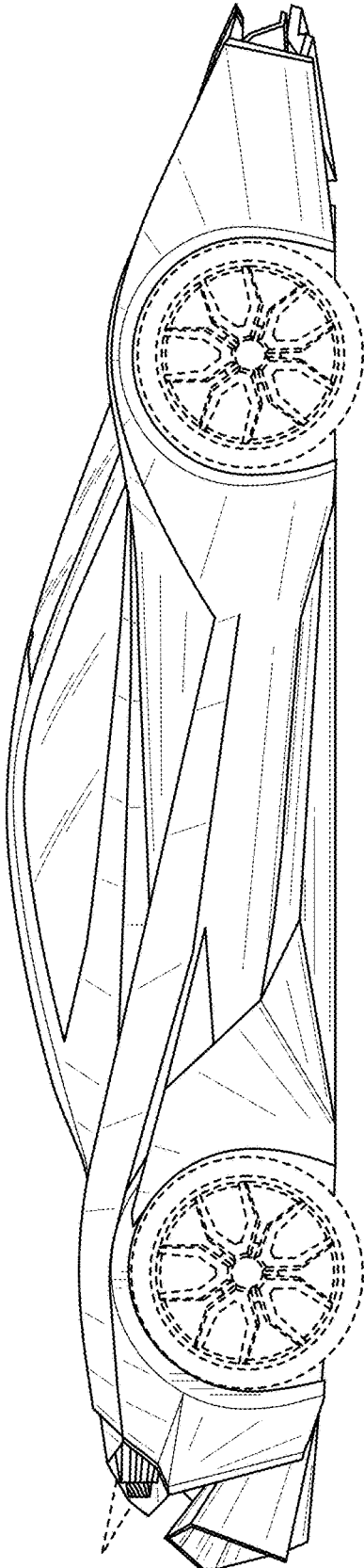

FIG. 11



FIG. 12

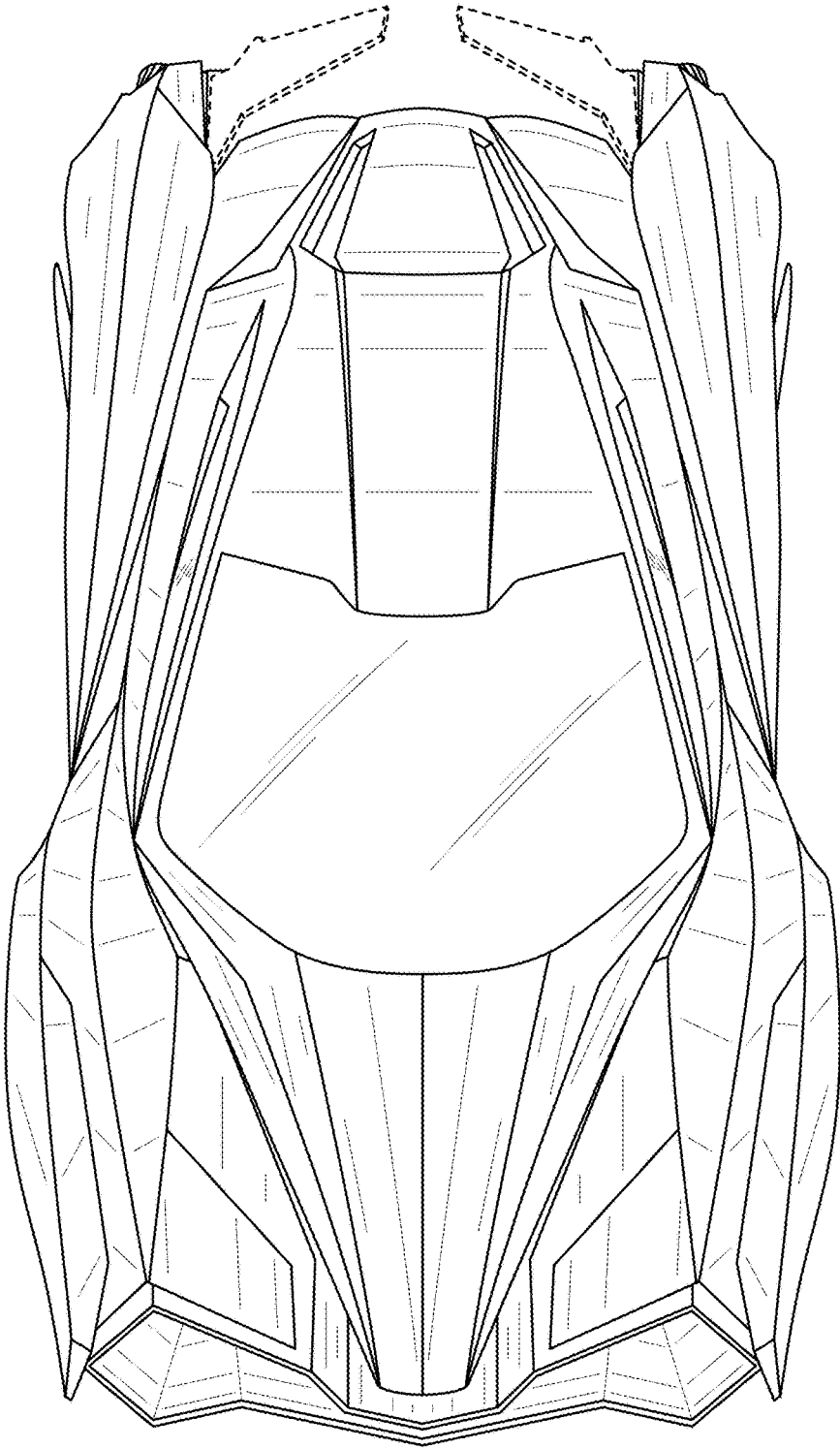

FIG. 13

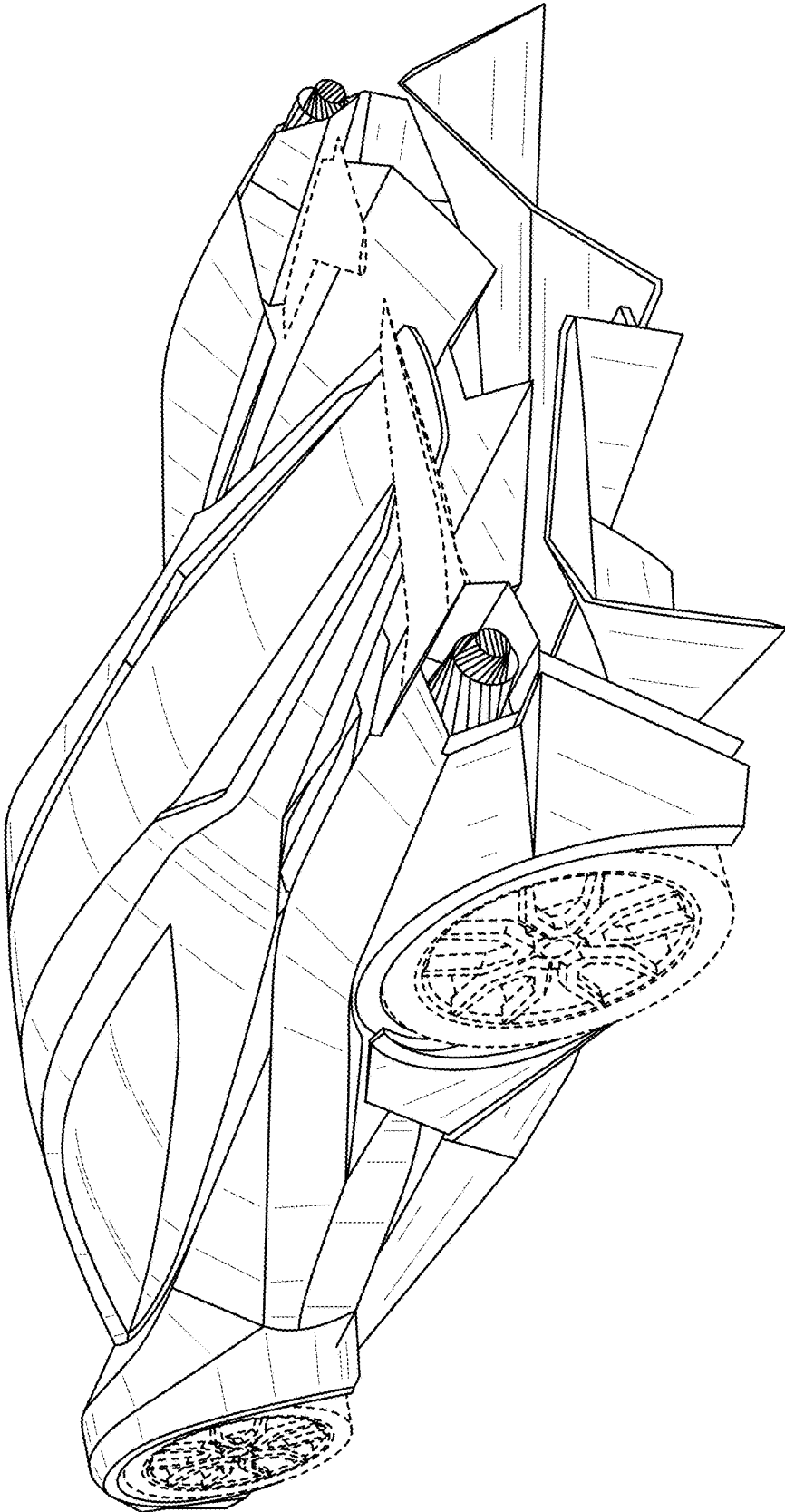

FIG. 14