

(12) **UK Patent Application** (19) **GB** (11) **2 425 754** (13) **A**

(43) Date of Printing by UK Office **08.11.2006**

(21) Application No: **0616786.0**

(22) Date of Filing: **14.02.2005**

(30) Priority Data:
(31) **10784122** (32) **20.02.2004** (33) **US**

(86) International Application Data:
PCT/US2005/004908 En 14.02.2005

(87) International Publication Data:
WO2005/082624 En 09.09.2005

(71) Applicant(s):
Speedline Technologies Inc
(Incorporated in USA - Delaware)
16 Forge Park, Franklin, MA 02038,
United States of America

(continued on next page)

(51) INT CL:
B41F 15/06 (2006.01) **B41F 35/00** (2006.01)
H05K 3/12 (2006.01)

(52) UK CL (Edition X):
B6C CBAP CEAS C106 C168 C630

(56) Documents Cited by ISA:
None

(58) Field of Search by ISA:
INT CL **B41F**
Other:

(54) Abstract Title: **Methods and apparatus for changing web material in a stencil printer**

(57) A quick-change material module of a stencil wiper assembly(56) for wiping a stencil(36) of a stencil printer(30) includes a supply roller(62) to receive a roll of material(64), a take-up roller(66) to receive used material, and a drive to move the material across the stencil(36) between the supply roller and the take-up roller. The supply roller(62) is designed to move between an operating position in which the module functions to wipe the stencil and a changing position in which the supply roller is accessible to change the roll of material. A pivot mechanism(90) is further disclosed for pivoting the supply roller between the operating and changing positions. A frame(76, 78) supports the supply roller, the take-up roller, and the drive(68). The pivot mechanism includes at least one pivot arm(92, 94) having one end rotatably attached to the supply roller and an opposite end pivotably attached to the frame. A method for changing a roll of material(64) within a quick-change material module of a stencil wiper assembly(56) designed to wipe a stencil(36) of a stencil printer (30) is further disclosed.

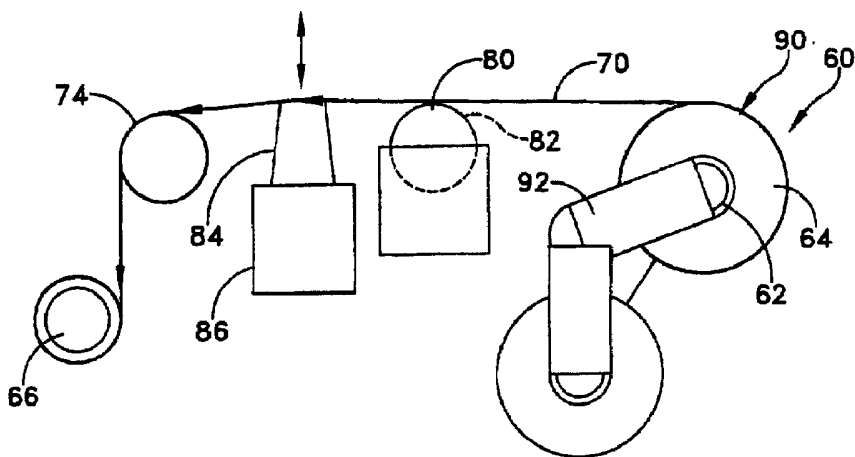

GB 2425754 A continuation

(72) Inventor(s):

**Joseph A Perault
Randy Leon Peckham
Gary T Freeman
Frank John Marsza-Lkowski Jr**

(74) Agent and/or Address for Service:

**Venner Shipley LLP
20 Little Britain, LONDON, EC1A 7DH,
United Kingdom**