



US 20040060508A1

(19) **United States**

(12) **Patent Application Publication**  
**Pacetti et al.**

(10) **Pub. No.: US 2004/0060508 A1**

(43) **Pub. Date: Apr. 1, 2004**

(54) **STENT MOUNTING DEVICE**

**Related U.S. Application Data**

(76) Inventors: **Stephen D. Pacetti**, San Jose, CA (US);  
**Plaridel K. Villareal**, San Jose, CA  
(US)

(62) Division of application No. 09/896,000, filed on Jun. 28, 2001, now Pat. No. 6,673,154.

**Publication Classification**

Correspondence Address:

**Paul J. Meyer, Jr.**  
**Squire, Sanders & Dempsey L.L.P.**  
**Suite 300**  
**1 Maritime Plaza**  
**San Francisco, CA 94111 (US)**

(51) **Int. Cl.<sup>7</sup>** ..... **B05C 1/00; B05C 11/00**  
(52) **U.S. Cl.** ..... **118/264; 118/205; 118/232**

(57) **ABSTRACT**

(21) Appl. No.: **10/662,223**

A stent mounting device and a method of coating a stent using the device are provided.

(22) Filed: **Sep. 12, 2003**

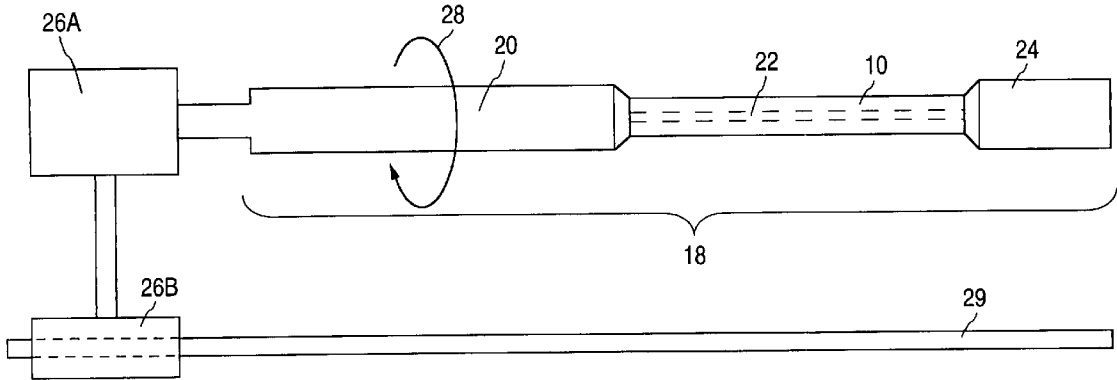

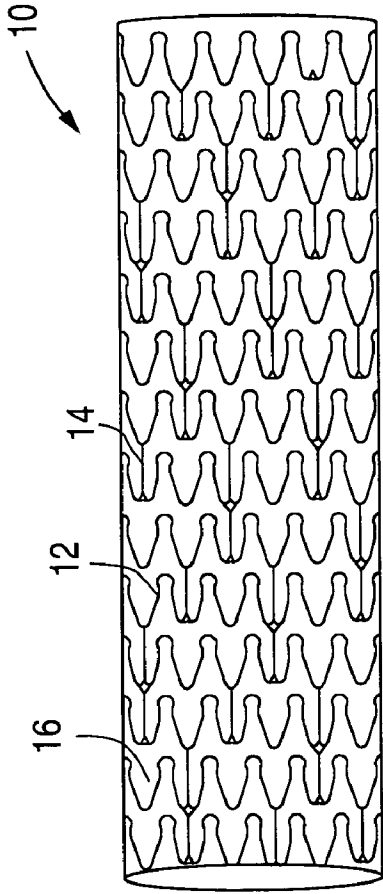

**FIGURE 1**  
(PRIOR ART)

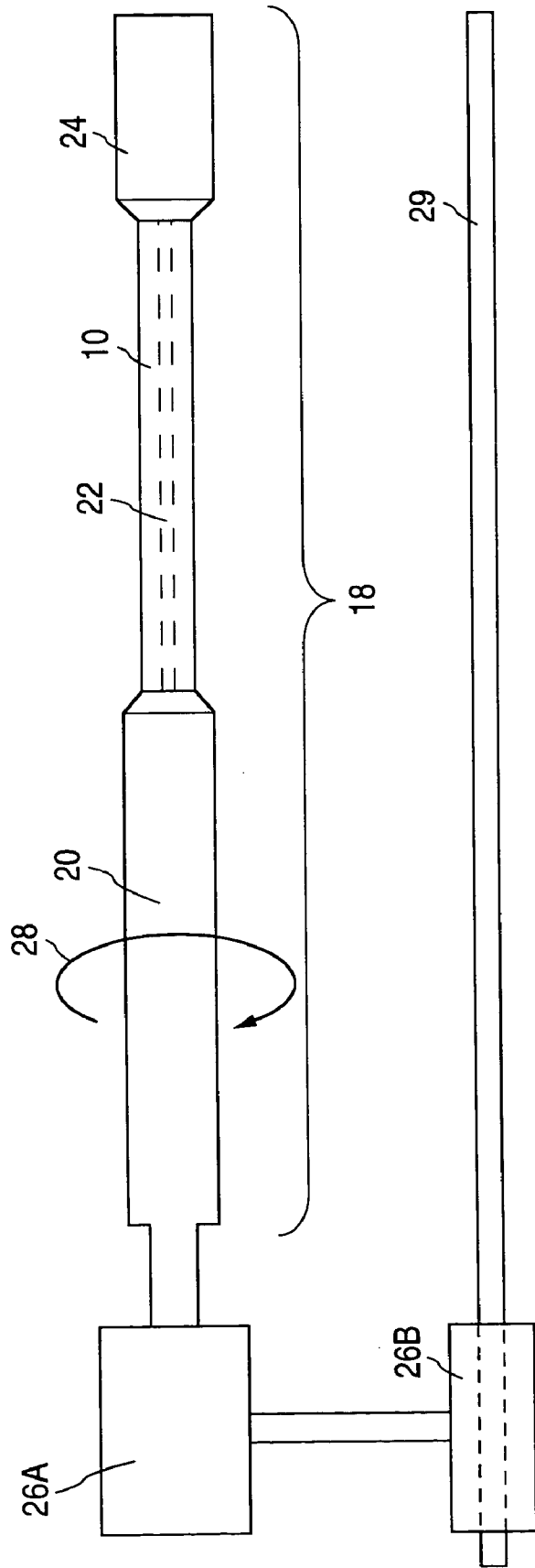

**Figure 2A**

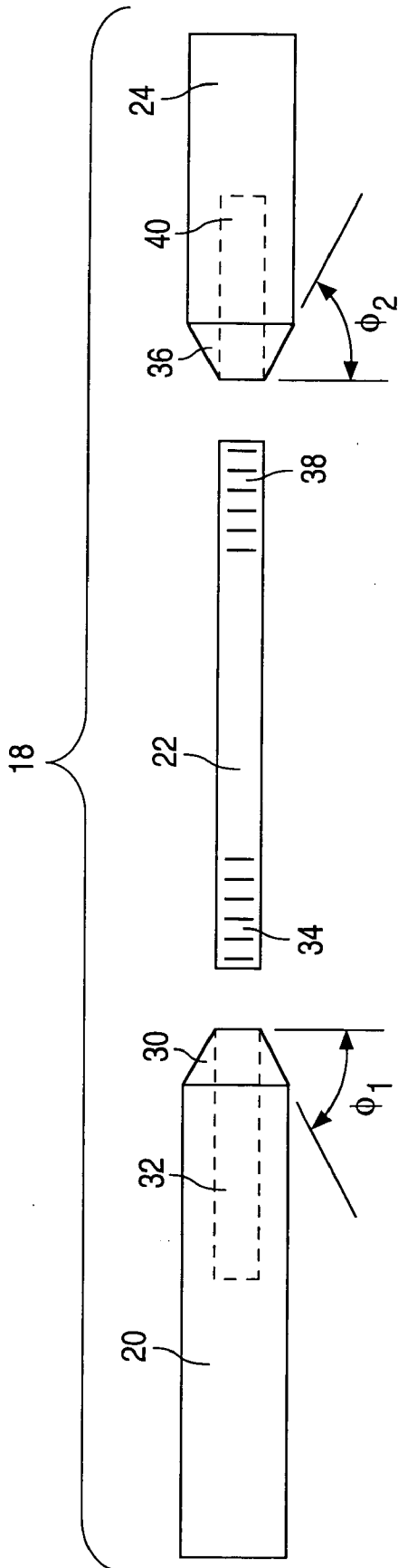

FIGURE 2B

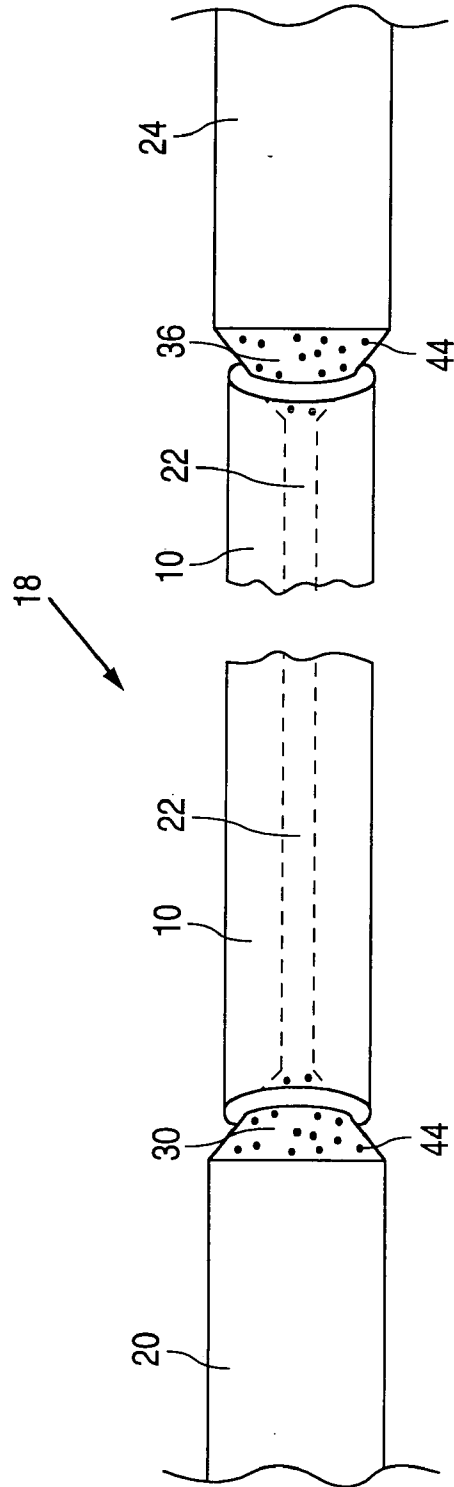
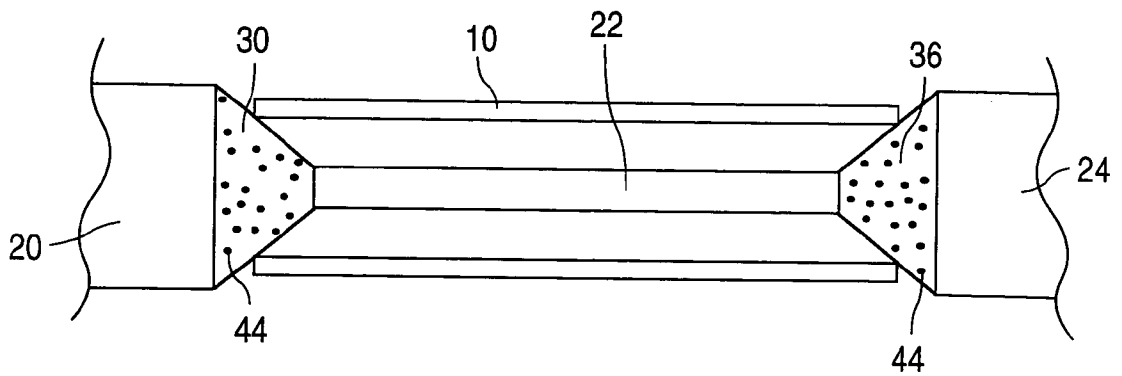
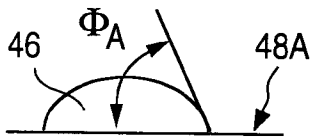

FIGURE 3A



**FIGURE 3B**



**FIGURE 4A**

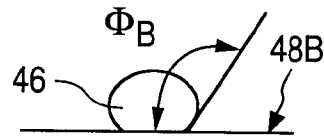

**FIGURE 4B**

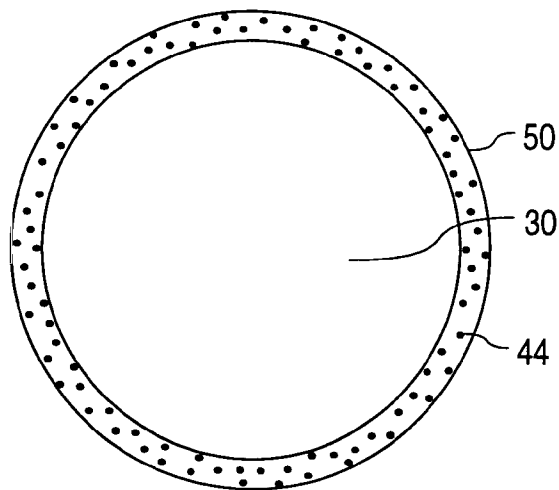

**FIGURE 5**

## STENT MOUNTING DEVICE

### BACKGROUND OF THE INVENTION

#### [0001] 1. Field of the Invention

[0002] This invention relates to a stent mounting device and a method of coating a stent using the device.

#### [0003] 2. Description of the Background

[0004] Blood vessel occlusions are commonly treated by mechanically enhancing blood flow in the affected vessels, such as by employing a stent. Stents act as scaffoldings, functioning to physically hold open and, if desired, to expand the wall of the passageway. Typically stents are capable of being compressed, so that they can be inserted through small lumens via catheters, and then expanded to a larger diameter once they are at the desired location. Examples in the patent literature disclosing stents include U.S. Pat. No. 4,733,665 issued to Palmaz, U.S. Pat. No. 4,800,882 issued to Gianturco, and U.S. Pat. No. 4,886,062 issued to Wiktor.

[0005] FIG. 1 illustrates a conventional stent 10 formed from a plurality of struts 12. The plurality of struts 12 are radially expandable and interconnected by connecting elements 14 that are disposed between adjacent struts 12, leaving lateral openings or gaps 16 between adjacent struts 12. Struts 12 and connecting elements 14 define a tubular stent body having an outer, tissue-contacting surface and an inner surface.

[0006] Stents are used not only for mechanical intervention but also as vehicles for providing biological therapy. Biological therapy can be achieved by medicating the stents. Medicated stents provide for the local administration of a therapeutic substance at the diseased site. Local delivery of a therapeutic substance is a preferred method of treatment because the substance is concentrated at a specific site and thus smaller total levels of medication can be administered in comparison to systemic dosages that often produce adverse or even toxic side effects for the patient.

[0007] One method of medicating a stent involves the use of a polymeric carrier coated onto the surface of the stent. A composition including a solvent, a polymer dissolved in the solvent, and a therapeutic substance dispersed in the blend is applied to the stent by immersing the stent in the composition or by spraying the composition onto the stent. The solvent is allowed to evaporate, leaving on the stent strut surfaces a coating of the polymer and the therapeutic substance impregnated in the polymer.

[0008] A shortcoming of the above-described method of medicating a stent is the potential for coating defects. While some coating defects can be minimized by adjusting the coating parameters, other defects occur due to the nature of the interface between the stent and the apparatus on which the stent is supported during the coating process. A high degree of surface contact between the stent and the supporting apparatus can provide regions in which the liquid composition can flow, wick, and collect as the composition is applied. As the solvent evaporates, the excess composition hardens to form excess coating at and around the contact points between the stent and the supporting apparatus. Upon the removal of the coated stent from the supporting apparatus, the excess coating may stick to the apparatus, thereby

removing some of the coating from the stent and leaving bare areas. Alternatively, the excess coating may stick to the stent, thereby leaving excess coating as clumps or pools on the struts or webbing between the struts.

[0009] Thus, it is desirable to minimize the potential for coating defects generated by the interface between the stent and the apparatus supporting the stent during the coating process. Accordingly, the present invention provides for a device for supporting a stent during the coating application process. The invention also provides for a method of coating the stent supported by the device.

### SUMMARY OF THE INVENTION

[0010] The present invention provides an apparatus for supporting a stent during a process of coating the stent. The apparatus includes a member for supporting a stent during the coating process, wherein a section of the member includes a porous surface capable of receiving the coating substance during the coating process. The pores can have a diameter between about 0.2 microns and about 50 microns.

[0011] In one embodiment, the member includes a first member for making contact with a first end of the stent and a second member for making contact with a second end of the stent. In such an embodiment, the pores can be located on at least a region of the surface of the first or second members. The first or second member can be made from a metallic material such as 300 Series stainless steel, 400 Series stainless steel, titanium, tantalum, niobium, zirconium, hafnium, and cobalt chromium alloys. The first or second member can also be made from a polymeric material such as, but not limited to, regenerated cellulose, cellulose acetate, polyacetal, polyetheretherketone, polyesters, highly hydrolyzed polyvinyl alcohol, nylon, polyphenylenesulfide, polyethylene, polyethylene terephthalate, polypropylene, and combinations thereof. The first or second member can also be made from ceramics such as, but not limited to, zirconia, silica, glass, sintered calcium phosphates, calcium sulfate, and titanium dioxide. In another embodiment, a layer can be disposed on the surface of the first or second member to absorb coating material that comes into contact with the layer.

[0012] In one embodiment, the first and second members have inwardly tapered ends that penetrate at least partially in the first and second ends of the stent and are in contact with the first and second ends of the stent. In another embodiment, the apparatus additionally includes a third member for extending within the stent and for securing the first member to the second member.

[0013] The present invention also provides a method of coating a stent. The method includes positioning a stent on a mounting assembly, wherein a section of the mounting assembly includes a porous surface. The method additionally includes applying a coating composition to the stent, wherein at least some of the coating composition that overflows from the stent is received by the pores. The act of applying a coating composition can include spraying the composition onto the stent.

[0014] In one embodiment, the method also includes at least partially expanding the stent prior to the act of applying. The method can also include rotating the stent about the longitudinal axis of the stent during the act of applying

and/or moving the stent in a linear direction along the longitudinal axis of the stent during the act of applying.

[0015] Also provided is a support assembly for a stent. The support assembly includes a member for supporting a stent, wherein the member includes an absorbing layer for at least partially absorbing some of the coating material that comes into contact with the absorbing layer.

#### BRIEF DESCRIPTION OF THE FIGURES

[0016] FIG. 1 illustrates a conventional stent.

[0017] FIG. 2A illustrates a mounting assembly for supporting a stent in accordance with one embodiment of the present invention.

[0018] FIG. 2B illustrates an expanded view of the mounting assembly in accordance with one embodiment of the present invention.

[0019] FIG. 3A illustrates the interface between the mounting assembly and the stent.

[0020] FIG. 3B is a cross-sectional view of the interface between the mounting assembly and the stent in FIG. 3A.

[0021] FIG. 4A illustrates a fluid on a solid substrate having a contact angle  $\phi_A$ ;

[0022] FIG. 4B illustrates a fluid on a solid substrate having a contact angle  $\phi_B$ ;

[0023] FIG. 5 illustrates an end view of a coning end portion having a porous covering over the outer surface thereof.

#### DETAILED DESCRIPTION

##### Embodiments of the Mounting Assembly

[0024] Referring to FIG. 2A, a mounting assembly 18 for supporting stent 10 is illustrated to include a support member 20, a mandrel 22, and a lock member 24. Support member 20 can connect to a motor 26A so as to provide rotational motion about the longitudinal axis of stent 10, as depicted by arrow 28, during the coating process. Another motor 26B can also be provided for moving support member 20 in a linear direction, back and forth, along a rail 29. The type of stent 10 is not of critical importance and can include radially expandable stents and stent-grafts.

[0025] Referring to FIG. 2B, support member 20 includes a coning end portion 30, tapering inwardly at an angle  $\phi_1$  of about 15° to about 75°, more narrowly from about 30° to about 60°. By way of example, angle  $\phi_1$  can be about 45°. In accordance with one embodiment, mandrel 22 can be permanently affixed to coning end portion 30. Alternatively, support member 20 can include a bore 32 for receiving a first end 34 of mandrel 22. First end 34 of mandrel 22 can be threaded to screw into bore 32. Alternatively, a non-threaded first end 34 and bore 32 combination can be employed such that first end 34 can be press-fitted or friction-fitted within bore 32 to prevent movement of stent 10 on mounting assembly 18. Bore 32 should be deep enough so as to allow mandrel 22 to securely mate with support member 20. The depth of bore 32 can also be over-extended so as to allow a significant length of mandrel 22 to penetrate bore 32. This would allow the length of mandrel 22 to be adjusted to accommodate stents of various sizes. In commercial

embodiments, support member 20 can be disposable or capable of being cleaned after each use, for example in a solvent or oxidizing bath, or by pyrolyzing out any absorbed coating materials via heating at high temperatures.

[0026] The outer diameter of mandrel 22 should be smaller than the inner diameter of stent 10 so as to prevent the outer surface of mandrel 22 from making contact with the inner surface of stent 10. A sufficient clearance between the outer surface of mandrel 22 and the inner surface of stent 10 should be provided to prevent mandrel 22 from obstructing the pattern of the stent body during the coating process. By way of example, the outer diameter of mandrel 22 can be from about 0.010 inches (0.254 mm) to about 0.017 inches (0.432 mm) when stent 10 has an inner diameter of between about 0.025 inches (0.635 mm) and about 0.035 inches (0.889 mm).

[0027] Lock member 24 includes a coning end portion 36 having an inwardly tapered angle  $\phi_2$ . Angle  $\phi_2$  can be the same as or different than the above-described angle  $\phi_1$ . A second end 38 of mandrel 22 can be permanently affixed to lock member 24 if end 34 is disengagable from support member 20. Alternatively, in accordance with another embodiment, mandrel 22 can have a threaded second end 38 for screwing into a bore 40 of lock member 24. Bore 40 can be of any suitable depth that would allow lock member 24 to be incrementally moved closer to support member 20. Accordingly, stents 10 of any length can be securely pinched between support and lock members 20 and 24. In accordance with yet another embodiment, a non-threaded second end 38 and bore 40 combination is employed such that second end 38 can be press-fitted or friction-fitted within bore 40. In commercial embodiments, lock member 24 can be disposable or capable of being cleaned after each use.

[0028] Mounting assembly 18 supports stent 10 via coning end portions 30 and 36. FIGS. 3A and 3B illustrate the interface between coning end portions 30 and 36 and each end of stent 10 so as to provide minimal contact between stent 10 and mounting assembly 18. Opposing forces exerted from support and lock members 20 and 24, for securely pinching stent 10, should be sufficiently strong so as to prevent any significant movement of stent 10 on mounting assembly 18. However, the exerted force should not compress stent 10 so as to distort the body of stent 10. Over or under application of support force can lead to coating defects, such as non-uniformity of the coating thickness.

[0029] In addition to supporting stent 10 with minimal contact, coning end portions 30 and 36 also function to reduce buildup of coating materials at the stent 10-mounting assembly 18 interface. Coning end portions 30 and 36 should be able to absorb the coating substance applied to stent 10. Thus, excess coating substance is absorbed into coning end portions 30 and 36 and drawn away from stent 10 during the coating process, further minimizing the potential for webbing and other coating defects at the interface between stent 10 and mounting assembly 18.

[0030] In one embodiment, the particular material selected for coning end portions 30 and 36 can be any material having a plurality of pores 44 suitable to receive or absorb the coating substance deposited thereon during the coating process. Pores 44 can be interconnected. Interconnected pore structures are also known as open pore systems as

opposed to closed pore systems in which pores **44** are isolated from one another. Interconnected pores **44** provide a network for moving and holding the coating substance, thus enabling coning end portions **30** and **36** to hold a larger amount of the coating substance than coning end portions **30** and **36** having discrete pores **44**, each with a fixed capacity for uptake of the substance. The diameter of pores **44** can be from about 0.2 microns to about 50 microns, for example about 1 micron.

[0031] Coning end portions **30** and **36** can be made of materials having a porous body or porous surfaces. Such materials can include ceramics, metals, and polymeric materials. In accordance with another embodiment, support member **20**, mandrel **22**, and/or lock member **24** can also be made to have a porous surface. Examples of suitable ceramics include, but are not limited to, zirconia, silica, glass, sintered calcium phosphates, calcium sulfate, and titanium dioxide.

[0032] Examples of suitable metals include, but are not limited to, 300 Series stainless steel, 400 Series stainless steel, titanium, tantalum, niobium, zirconium, hafnium, and cobalt chromium alloys. Surfaces having pores **44** can be made, for example, by sintering pre-formed metallic particles together to form porous blanks that can then be machined to a suitable shape or by sintering metallic particles together in a suitably-shaped mold. In alternative embodiments, the metal can be etched or bead-blasted to form a porous surface. Etching can be conducted by exposing the surface to a laser discharge, such as that of an excimer laser, or to a suitable chemical etchant.

[0033] Examples of suitable polymeric materials include, but are not limited to, regenerated cellulose, cellulose acetate, polyacetal, polyetheretherketone, polyesters, highly hydrolyzed polyvinyl alcohol, nylon, polyphenylenesulfide, polyethylene, polyethylene terephthalate, polypropylene, and combinations thereof. Methods of making polymers having pores **44**, such as by foaming, sintering particles to form a porous block, and phase inversion processing, are understood by one of ordinary skill in the art. The polymeric material selected should not be capable of swelling, dissolving, or adversely reacting with the coating substance.

[0034] In one suitable embodiment, the polymeric material from which the components are made is selected to allow the coating substance to have a high capillary permeation when a droplet of the coating substance is placed thereon. Capillary permeation or wetting is the movement of a fluid on a solid substrate driven by interfacial energetics. Capillary permeation is quantitated by a contact angle, defined as an angle at the tangent of a droplet in a fluid phase that has taken an equilibrium shape on a solid surface. A low contact angle indicates a higher wetting liquid. A suitably high capillary permeation corresponds to a contact angle less than about 90°. FIG. 4A illustrates a droplet **46** of the coating substance on a flat, nonporous surface **48A** composed of the same material as coning end portion **30** or **36**. Fluid droplet **46** has a high capillary permeation that corresponds to a contact angle  $\phi_A$ , which is less than about 90°. By contrast, FIG. 4B illustrates fluid droplet **46** on a surface **48B** having a low capillary permeation that corresponds to a contact angle  $\phi_B$ , which is greater than about 90°. Surface treatments understood by one of ordinary skill in the art, such as plasma treating, corona treating, chemical oxidation,

and etching, can be used to modify the surface to render the surface more capable of allowing the coating substance to have a suitably high capillary permeation.

[0035] FIG. 5 illustrates an embodiment in which the outer surface of coning end portions **30** and/or **36** is covered with a layer **50**. In such an embodiment, coning end portions **30** and/or **36** can have either porous or non-porous surfaces, while layer **50** can be made of an absorbent material, such as a sponge. Accordingly, layer **50** can absorb excess coating substance flowing off of stent **10**. In addition, support member **20**, mandrel **22**, and/or lock member **24** can also be covered with layer **50**.

[0036] While the device of the present invention has been described herein as having coning end portions **30** and **36** that support the respective ends of a stent and draw excess coating materials away from the stent via pores **44**, it should be understood that the present invention is not limited thereto. Rather, the stent mounting assembly of the present invention can be any device that includes porous regions for supporting a stent as well as for absorbing excess coating materials to minimize coating defects.

#### Coating a Stent Using the Mounting Assembly

[0037] The following method of application is being provided by way of illustration and is not intended to limit the embodiments of mounting assembly **18** of the present invention. A spray apparatus, such as EFD 780S spray device with VALVEMATE 7040 control system (manufactured by EFD Inc., East Providence, R.I.), can be used to apply a composition to a stent. EFD 780S spray device is an air-assisted external mixing atomizer. The composition is atomized into small droplets by air and uniformly applied to the stent surfaces. The atomization pressure can be maintained at a range of about 5 psi to about 20 psi. The droplet size depends on such factors as viscosity of the solution, surface tension of the solvent, and atomization pressure. Other types of spray applicators, including air-assisted internal mixing atomizers and ultrasonic applicators, can also be used for the application of the composition.

[0038] During the application of the composition, a stent supported by mounting assembly **18** can be rotated about the stent's central longitudinal axis. Rotation of the stent can be from about 1 rpm to about 300 rpm, more narrowly from about 50 rpm to about 150 rpm. By way of example, the stent can rotate at about 120 rpm. The stent can also be moved in a linear direction along the same axis. The stent can be moved at about 1 mm/second to about 12 mm/second, for example about 6 mm/second, or for a minimum of at least two passes (i.e., back and forth past the spray nozzle). The flow rate of the solution from the spray nozzle can be from about 0.01 mg/second to about 0.1 mg/second, more narrowly about 0.1 mg/second. Multiple repetitions for applying the composition can be performed, wherein each repetition can be, for example, about 1 second to about 10 seconds in duration. The amount of coating applied by each repetition can be about 0.1 micrograms/cm<sup>2</sup> (of stent surface) to about 40 micrograms/cm<sup>2</sup>, for example less than about 2 micrograms/cm<sup>2</sup> per 5-second spray.

[0039] Each repetition can be followed by removal of a significant amount of the solvent. Depending on the volatility of the particular solvent employed, the solvent can evaporate essentially upon contact with the stent. Alterna-

tively, removal of the solvent can be induced by baking the stent in an oven at a mild temperature (e.g., 60° C.) for a suitable duration of time (e.g., 2-4 hours) or by the application of warm air. The application of warm air between each repetition prevents coating defects and minimizes interaction between the active agent and the solvent. The temperature of the warm air can be from about 30° C. to about 60° C., more narrowly from about 40° C. to about 50° C. The flow rate of the warm air can be from about 20 cubic feet/minute (CFM) (0.57 cubic meters/minute (CMM)) to about 80 CFM (2.27 CMM), more narrowly about 30 CFM (0.85 CMM) to about 40 CFM (1.13 CMM). The warm air can be applied for about 3 seconds to about 60 seconds, more narrowly for about 10 seconds to about 20 seconds. By way of example, warm air applications can be performed at a temperature of about 50° C., at a flow rate of about 40 CFM, and for about 10 seconds. Any suitable number of repetitions of applying the composition followed by removing the solvent(s) can be performed to form a coating of a desired thickness or weight. Excessive application of the polymer in a single application can, however, cause coating defects.

**[0040]** Operations such as wiping, centrifugation, or other web clearing acts can also be performed to achieve a more uniform coating. Briefly, wiping refers to the physical removal of excess coating from the surface of the stent; and centrifugation refers to rapid rotation of the stent about an axis of rotation. The excess coating can also be vacuumed off of the surface of the stent.

**[0041]** In accordance with one embodiment, the stent can be at least partially pre-expanded prior to the application of the composition. For example, the stent can be radially expanded about 20% to about 60%, more narrowly about 27% to about 55% the measurement being taken from the stent's inner diameter at an expanded position as compared to the inner diameter at the unexpanded position. The expansion of the stent, for increasing the interspace between the stent struts during the application of the composition, can further prevent "cob web" formation between the stent struts.

**[0042]** In accordance with one embodiment, the composition can include a solvent and a polymer dissolved in the solvent. The composition can also include active agents, radiopaque elements, or radioactive isotopes. Representative examples of polymers that can be used to coat a stent include ethylene vinyl alcohol copolymer (commonly known by the generic name EVOH or by the trade name EVAL), poly(hydroxyvalerate); poly(L-lactic acid); polycaprolactone; poly(lactide-coglycolide); poly(hydroxybutyrate); poly(hydroxybutyrate-co-valerate); polydioxanone; polyorthoester; polyanhydride; poly(glycolic acid); poly(D,L-lactic acid); poly(glycolic acid-co-trimethylene carbonate); polyphosphoester; polyphosphoester urethane; poly(amino acids); cyanoacrylates; poly(trimethylene carbonate); poly(iminocarbonate); copoly(ether-esters) (e.g. PEO/PLA); polyalkylene oxalates; polyphosphazenes; biomolecules, such as fibrin, fibrinogen, cellulose, starch, collagen and hyaluronic acid; polyurethanes; silicones; polyesters; polyolefins; polyisobutylene and ethylene-alphaolefin copolymers; acrylic polymers and copolymers; vinyl halide polymers and copolymers, such as polyvinyl chloride; polyvinyl ethers, such as polyvinyl methyl ether; polyvinylidene halides, such as polyvinylidene fluoride and polyvinylidene chloride; polyacrylonitrile; polyvinyl ketones; polyvinyl aromatics,

such as polystyrene; polyvinyl esters, such as polyvinyl acetate; copolymers of vinyl monomers with each other and olefins, such as ethylene-methyl methacrylate copolymers, acrylonitrile-styrene copolymers, ABS resins, and ethylene-vinyl acetate copolymers; polyamides, such as Nylon 66 and polycaprolactam; alkyd resins; polycarbonates; polyoxymethylenes; polyimides; polyethers; epoxy resins; polyurethanes; rayon; rayon-triacetate; cellulose; cellulose acetate; cellulose butyrate; cellulose propionate butyrate; cellophane; cellulose nitrate; cellulose propionate; cellulose ethers; and carboxymethyl cellulose.

**[0043]** "Solvent" is defined as a liquid substance or composition that is compatible with the polymer and is capable of dissolving the polymer at the concentration desired in the composition. Examples of solvents include, but are not limited to, dimethylsulfoxide (DMSO), chloroform, acetone, water (buffered saline), xylene, methanol, ethanol, 1-propanol, tetrahydrofuran, 1-butanone, dimethylformamide, dimethylacetamide, cyclohexanone, ethyl acetate, methyl-ethylketone, propylene glycol monomethylether, isopropanol, isopropanol admixed with water, N-methyl pyrrolidinone, toluene, and combinations thereof.

**[0044]** The active agent could be for inhibiting the activity of vascular smooth muscle cells. More specifically, the active agent can be aimed at inhibiting abnormal or inappropriate migration and/or proliferation of smooth muscle cells for the inhibition of restenosis. The active agent can also include any substance capable of exerting a therapeutic or prophylactic effect in the practice of the present invention. For example, the agent can be for enhancing wound healing in a vascular site or improving the structural and elastic properties of the vascular site. Examples of agents include antiproliferative substances such as actinomycin D, or derivatives and analogs thereof (manufactured by Sigma-Aldrich 1001 West Saint Paul Avenue, Milwaukee, Wis. 53233; or COSMEGEN available from Merck). Synonyms of actinomycin D include dactinomycin, actinomycin IV, actinomycin I<sub>1</sub>, actinomycin X<sub>1</sub>, and actinomycin C<sub>1</sub>. The active agent can also fall under the genus of antineoplastic, antiinflammatory, antiplatelet, anticoagulant, antifibrin, anti-thrombin, antimetabolic, antibiotic, antiallergic and antioxidant substances. Examples of such antineoplastics and/or antimetotics include paclitaxel (e.g. TAXOL<sup>®</sup> by Bristol-Myers Squibb Co., Stamford, Conn.), docetaxel (e.g. Taxotere<sup>®</sup>, from Aventis S.A., Frankfurt, Germany) methotrexate, azathioprine, vincristine, vinblastine, fluorouracil, doxorubicin hydrochloride (e.g. Adriamycin<sup>®</sup> from Pharmacia & Upjohn, Peapack N.J.), and mitomycin (e.g. Mutamycin<sup>®</sup> from Bristol-Myers Squibb Co., Stamford, Conn.) Examples of such antiplatelets, anticoagulants, antifibrin, and anti-thrombins include sodium heparin, low molecular weight heparins, heparinoids, hirudin, argatroban, forskolin, vapiprost, prostacyclin and prostacyclin analogues, dextran, D-phe-pro-arg-chloromethylketone (synthetic antithrombin), dipyridamole, glycoprotein IIb/IIIa platelet membrane receptor antagonist antibody, recombinant hirudin, and thrombin inhibitors such as AngiomaxT<sup>™</sup> (Biogen, Inc., Cambridge, Mass.) Examples of such cytostatic or antiproliferative agents include angiostatin, angiotensin converting enzyme inhibitors such as captopril (e.g. Capoten<sup>®</sup> and Capozide<sup>®</sup> from Bristol-Myers Squibb Co., Stamford, Conn.), cilazapril or lisinopril (e.g. Prinivil<sup>®</sup> and Prinzipide<sup>®</sup> from Merck & Co., Inc., Whitehouse Station, N.J.); calcium channel blockers (such as nifedipine), colchicine, fibroblast



growth factor (FGF) antagonists, fish oil (omega 3-fatty acid), histamine antagonists, lovastatin (an inhibitor of HMG-CoA reductase, a cholesterol lowering drug, brand name Mevacor® from Merck & Co., Inc., Whitehouse Station, N.J.), monoclonal antibodies (such as those specific for Platelet-Derived Growth Factor (PDGF) receptors), nitroprusside, phosphodiesterase inhibitors, prostaglandin inhibitors, suramin, serotonin blockers, steroids, thioprotease inhibitors, triazolopyrimidine (a PDGF antagonist), and nitric oxide. An example of an antiallergic agent is permirolast potassium. Other therapeutic substances or agents which may be appropriate include alpha-interferon, genetically engineered epithelial cells, rapamycin and dexamethasone. Exposure of the active ingredient to the composition should not adversely alter the active ingredient's composition or characteristic. Accordingly, the particular active ingredient is selected for compatibility with the solvent or blended polymer-solvent.

**[0045]** Examples of radiopaque elements include, but are not limited to, gold, tantalum, and platinum. An example of a radioactive isotope is P<sup>32</sup>. Sufficient amounts of such substances may be dispersed in the composition such that the substances are not present in the composition as agglomerates or flocs.

**[0046]** While particular embodiments of the present invention have been shown and described, it will be obvious to those skilled in the art that changes and modifications can be made without departing from this invention in its broader aspects. Therefore, the appended claims are to encompass within their scope all such changes and modifications as fall within the true spirit and scope of this invention.

What is claimed is:

1. An apparatus for supporting a stent during a process of coating the stent, comprising:

a member for supporting a stent during the coating process, wherein a section of the member includes a porous surface capable of receiving the coating substance during the coating process.

2. The apparatus of claim 1, wherein the pores have a diameter between about 0.2 microns and about 50 microns.

3. The apparatus of claim 1, wherein the member includes a first member for making contact with a first end of the stent and a second member for making contact with a second end of the stent and wherein the pores are located on at least a region of the surface of the first or second members.

4. The apparatus of claim 3, wherein the first or second member is made from a metallic material selected from a group of 300 Series stainless steel, 400 Series stainless steel, titanium, tantalum, niobium, zirconium, hafnium, and cobalt chromium alloys.

5. The apparatus of claim 3, wherein the first or second member is made from a polymeric material.

6. The apparatus of claim 5, wherein the polymeric material is selected from a group of regenerated cellulose, cellulose acetate, polyacetal, polyetheretherketone, polyesters, highly hydrolyzed polyvinyl alcohol, nylon, polyphenylenesulfide, polyethylene, polyethylene terephthalate, polypropylene, and combinations thereof.

7. The apparatus of claim 3, wherein the first or second member is made from a ceramic material selected from a group of zirconia, silica, glass, sintered calcium phosphates, calcium sulfate, and titanium dioxide.

8. The apparatus of claim 3, wherein the first and second members have inwardly tapered ends that penetrate at least partially in the first and second ends of the stent and are in contact with the first and second ends of the stent.

9. The apparatus of claim 3, additionally comprising a third member for extending within the stent and for securing the first member to the second member.

10. The apparatus of claim 9, wherein the outer surface of the third member does not make contact with the inner surface of the stent.

11. The apparatus of claim 1, wherein the member includes a first member for making contact with a first end of the stent, a second member for making contact with a second end of the stent, and a layer disposed on the surface of the first or second member to absorb coating material that comes into contact with the layer.

12. A mounting assembly for supporting a stent during the application of a coating composition onto the stent, comprising:

a support member including means for receiving and containing the excess coating composition applied to the stent during the application process.

13. The mounting assembly of claim 12, wherein the means is defined by a plurality of pores made on a selected region of the support member.

14. The mounting assembly of claim 12, wherein the support member includes a first member for supporting a first end of the stent and a second member for supporting a second end of the stent and wherein the surface of the first or second member includes cavities.

15. The mounting assembly of claim 14, wherein the support member additionally includes a third member for extending within the stent and for securing the first member to the second member and wherein the distance between the first member and the second member can be adjusted by inserting the third member deeper into the first member or the second member.

16. The mounting assembly of claim 12, wherein the support member includes a first member for supporting a first end of the stent, a second member for supporting a second end of the stent, and a layer disposed on the surface of the first or second member to absorb coating material that comes into contact with the layer.

17. A method of coating a stent, comprising:

positioning a stent on a mounting assembly, wherein a section of the mounting assembly includes a porous surface; and

applying a coating composition to the stent, wherein at least some of the coating composition that overflows from the stent is received by the pores.

18. The method of claim 17, wherein the mounting assembly includes a first member for making contact with a first end of the stent and a second member for making contact with a second end of the stent and wherein the pores are located on at least a region of the surface of the first or second members.

**19.** The method of claim 17, additionally comprising at least partially expanding the stent prior to the act of applying.

**20.** The method of claim 17, wherein the coating composition includes a solvent, a polymer dissolved in the solvent, and optionally a therapeutic substance.

**21.** The method of claim 17, additionally comprising rotating the stent about the longitudinal axis of the stent during the act of applying.

**22.** The method of claim 17, additionally comprising moving the stent in a linear direction along the longitudinal axis of the stent during the act of applying.

**23.** The method of claim 17, wherein the act of applying a coating composition comprises spraying the coating composition onto the stent.

**24.** A support assembly for a stent, comprising:

a member for supporting a stent, wherein the member includes an absorbing layer for at least partially absorbing some of the coating material that comes into contact with the absorbing layer.

\* \* \* \* \*