



US00D788644S

(12) **United States Design Patent**
Mueller

(10) **Patent No.:** **US D788,644 S**

(45) **Date of Patent:** **** Jun. 6, 2017**

(54) **MOTOR CAR**

(71) Applicant: **GM Global Technology Operations LLC**, Detroit, MI (US)

(72) Inventor: **Uwe Mueller**, Wiesbaden (DE)

(73) Assignee: **GM Global Technology Operations LLC**, Detroit, MI (US)

(**) Term: **15 Years**

(21) Appl. No.: **29/543,783**

(22) Filed: **Oct. 28, 2015**

(30) **Foreign Application Priority Data**

Apr. 29, 2015 (EM) 002691444

(51) **LOC (10) CL.** **12-08**

(52) **U.S. CL.**
USPC **D12/91**

(58) **Field of Classification Search**
USPC D12/86, 90-92, 88; D21/421, 433, 434;
296/181.1, 181.5
CPC B62D 35/00; B62D 25/00; B62D 25/06;
B62D 33/00
See application file for complete search history.

(56) **References Cited**

U.S. PATENT DOCUMENTS

D570,742 S	6/2008	Takagi et al.
D592,105 S	5/2009	Dean et al.
D597,447 S	8/2009	Folden
D600,595 S	9/2009	Nakamura et al.
D601,925 S	10/2009	O'Donnell
D603,755 S	11/2009	Peters
D604,203 S	11/2009	O'Donnell
D605,082 S	12/2009	Munson
D605,083 S	12/2009	Manoogian, II et al.
D605,977 S	12/2009	Zipfel et al.

D605,978 S	12/2009	Wolff et al.
D608,249 S	1/2010	Peters
D608,690 S	1/2010	Folden et al.
D608,691 S	1/2010	Zak, Jr. et al.
D609,608 S	2/2010	Boniface et al.
D611,387 S	3/2010	Thompson et al.
D611,879 S	3/2010	Kim et al.
D612,297 S	3/2010	Peters et al.
D613,645 S	4/2010	Song et al.
D615,458 S	5/2010	Thompson et al.
D618,595 S	6/2010	Ware et al.
D623,090 S	9/2010	Cox et al.
D627,262 S	11/2010	Ikeda et al.
D635,488 S	4/2011	Phipps
D644,147 S	8/2011	Suh et al.
D644,567 S	9/2011	Kozub
D657,718 S	4/2012	Zipfel et al.
D659,052 S	5/2012	Ware et al.
D659,053 S	5/2012	Ware et al.
D668,182 S	10/2012	Barba Franco et al.
D668,183 S	10/2012	Smart

(Continued)

Primary Examiner — Melody N Brown

(74) *Attorney, Agent, or Firm* — Reising Ethington P.C.

(57) **CLAIM**

The ornamental design for a motor car, as shown and described.

DESCRIPTION

FIG. 1 is a front and left side perspective view of the motor car;

FIG. 2 is a rear and right side perspective view thereof;

FIG. 3 is a right side elevation view thereof;

FIG. 4 is a left side elevation view thereof;

FIG. 5 is a front elevation view thereof;

FIG. 6 is a rear elevation view thereof; and,

FIG. 7 is a top plan view thereof.

The broken lines shown in the drawings depict portions of the motor car that form no part of the claimed design.

1 Claim, 6 Drawing Sheets

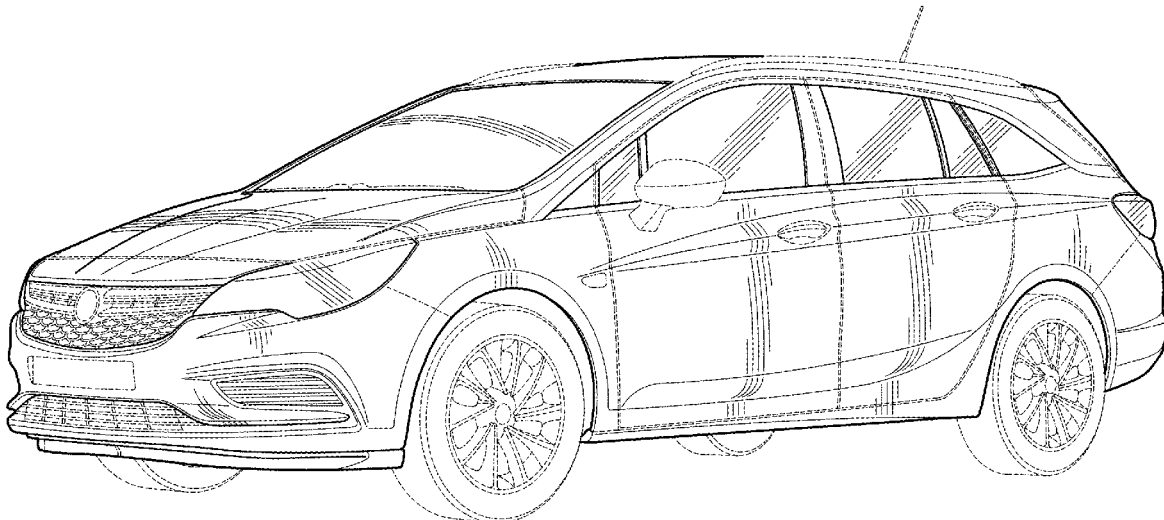

(56)

References Cited

U.S. PATENT DOCUMENTS

D678,820 S	3/2013	Son et al.	D718,683 S	12/2014	Thole et al.
D678,821 S	3/2013	Ikeda et al.	D722,282 S	2/2015	Loeb
D680,909 S	4/2013	Munson et al.	D722,533 S	2/2015	Thole et al.
D680,910 S	4/2013	David	D722,534 S	2/2015	Munson et al.
D684,899 S	6/2013	Baker	D724,510 S	3/2015	McMahan et al.
D686,536 S	7/2013	McCabe et al.	D725,001 S	3/2015	McMahan et al.
D692,798 S	11/2013	Thurber	D726,591 S	4/2015	Jacob
D692,799 S	11/2013	Smith et al.	D730,776 S	6/2015	Smart
D696,157 S	12/2013	Loeb	D730,783 S	6/2015	Henriques et al.
D699,629 S	2/2014	Ikeda et al.	D732,427 S	6/2015	Loeb
D700,871 S	3/2014	O'Donnell et al.	D732,429 S	6/2015	Loeb
D703,103 S	4/2014	Lee	D732,430 S	6/2015	Loeb
D704,103 S	5/2014	Mack et al.	D732,431 S	6/2015	Loeb
D705,132 S	5/2014	Ware et al.	D732,432 S	6/2015	Aengenheyster
D705,699 S	5/2014	Ware et al.	D732,433 S	6/2015	Aengenheyster
D713,298 S	9/2014	Dyson	D732,435 S	6/2015	Mackay
D713,764 S	9/2014	Ferlazzo	D733,002 S	6/2015	Loeb
D716,696 S	11/2014	Thole et al.	D735,611 S	8/2015	Aengenheyster
D716,706 S	11/2014	Thole et al.	D735,627 S	8/2015	Smith
D716,709 S	11/2014	Thole et al.	D736,451 S	8/2015	Smith
D717,696 S	11/2014	Thole et al.	D739,306 S	9/2015	McMahan et al.
D718,189 S	11/2014	Krieg et al.	D739,317 S	9/2015	McMahan et al.
			D741,223 S	10/2015	Kim et al.
			D764,976 S *	8/2016	Aengenheyster D12/91

* cited by examiner

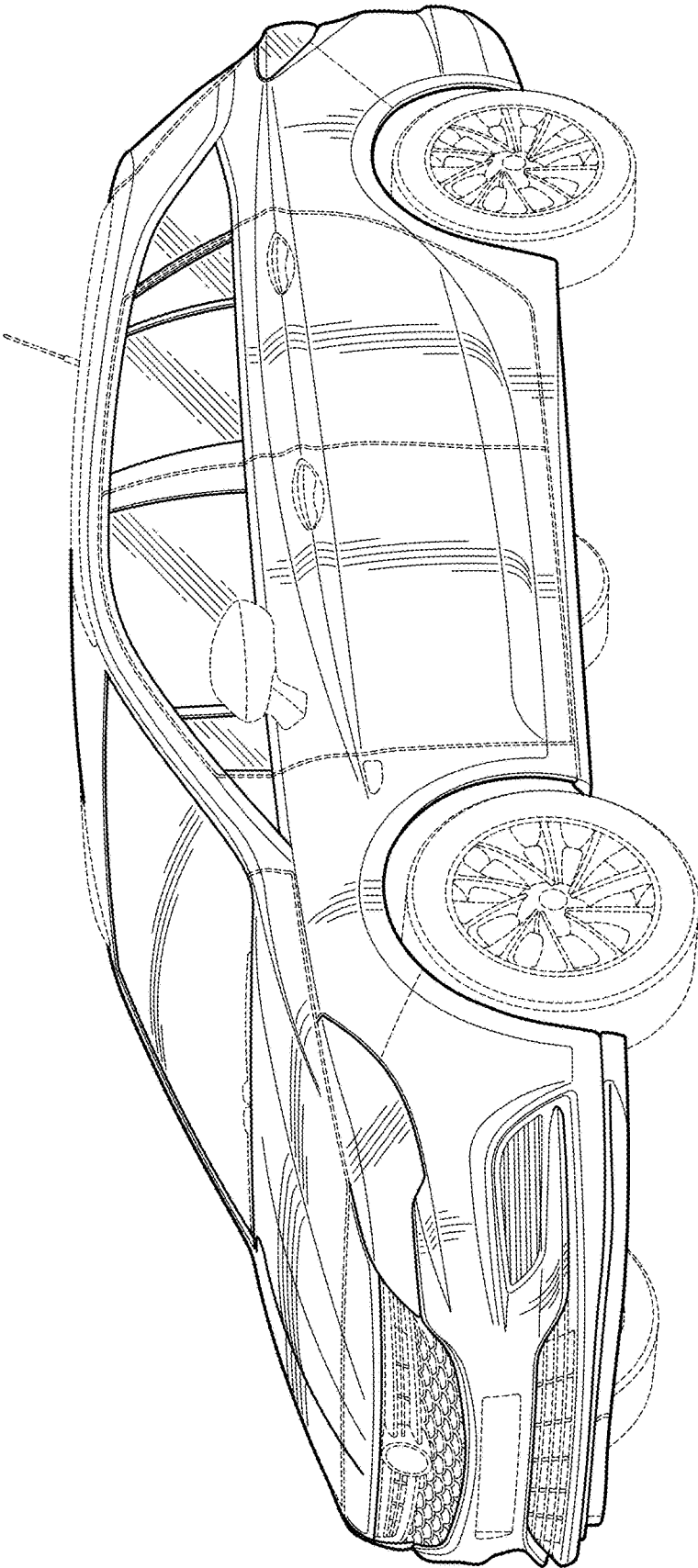

FIG. 1

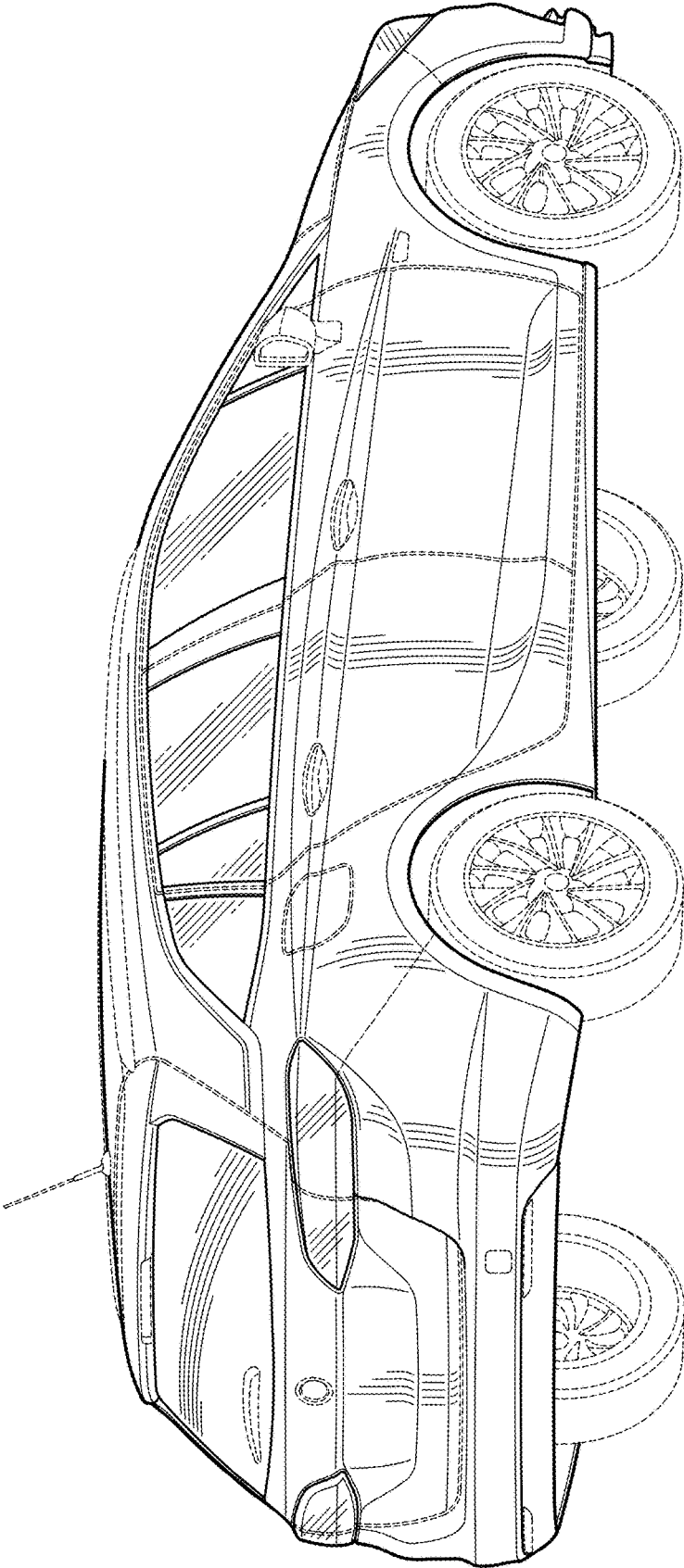

FIG. 2

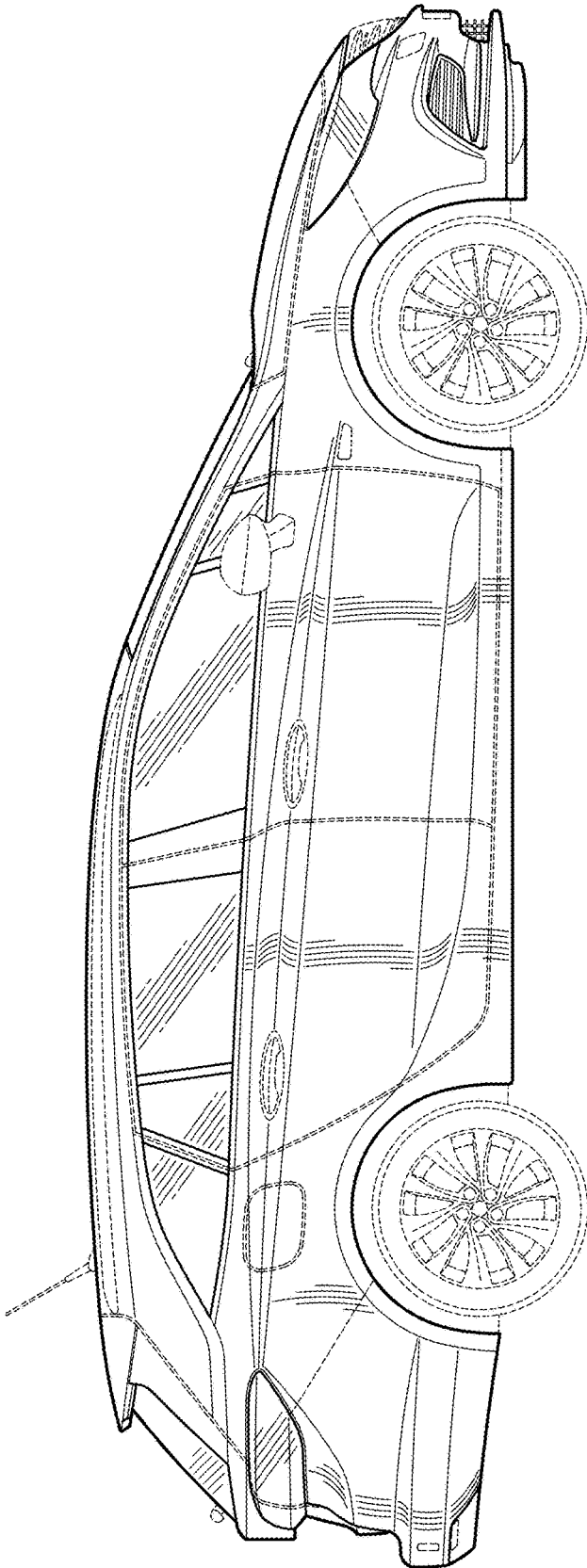

FIG. 3

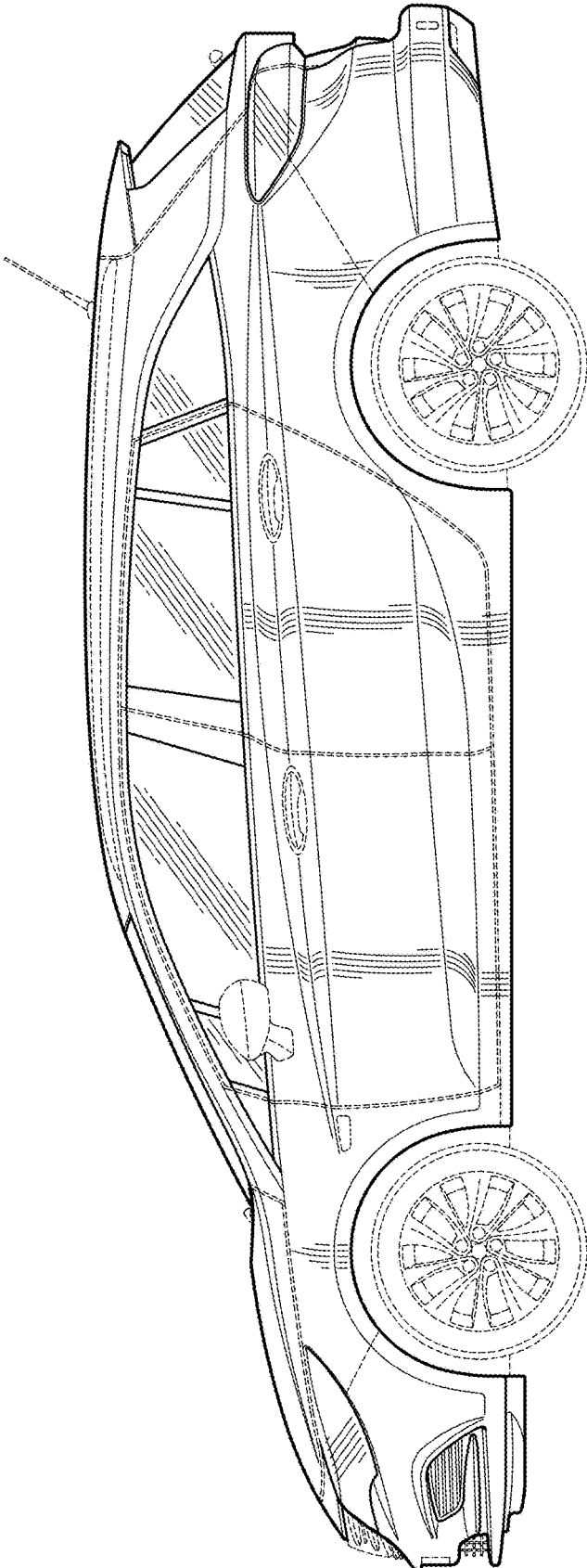

FIG. 4

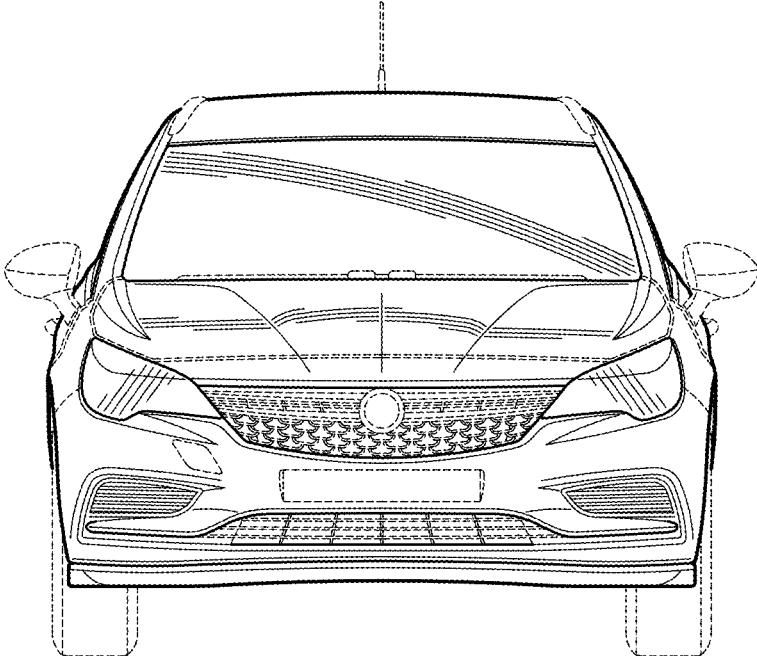

FIG. 5

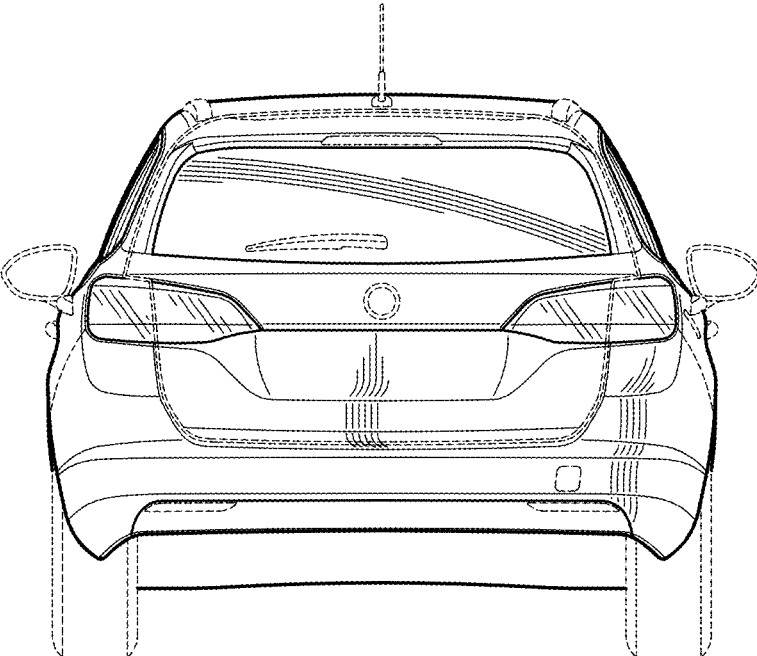

FIG. 6

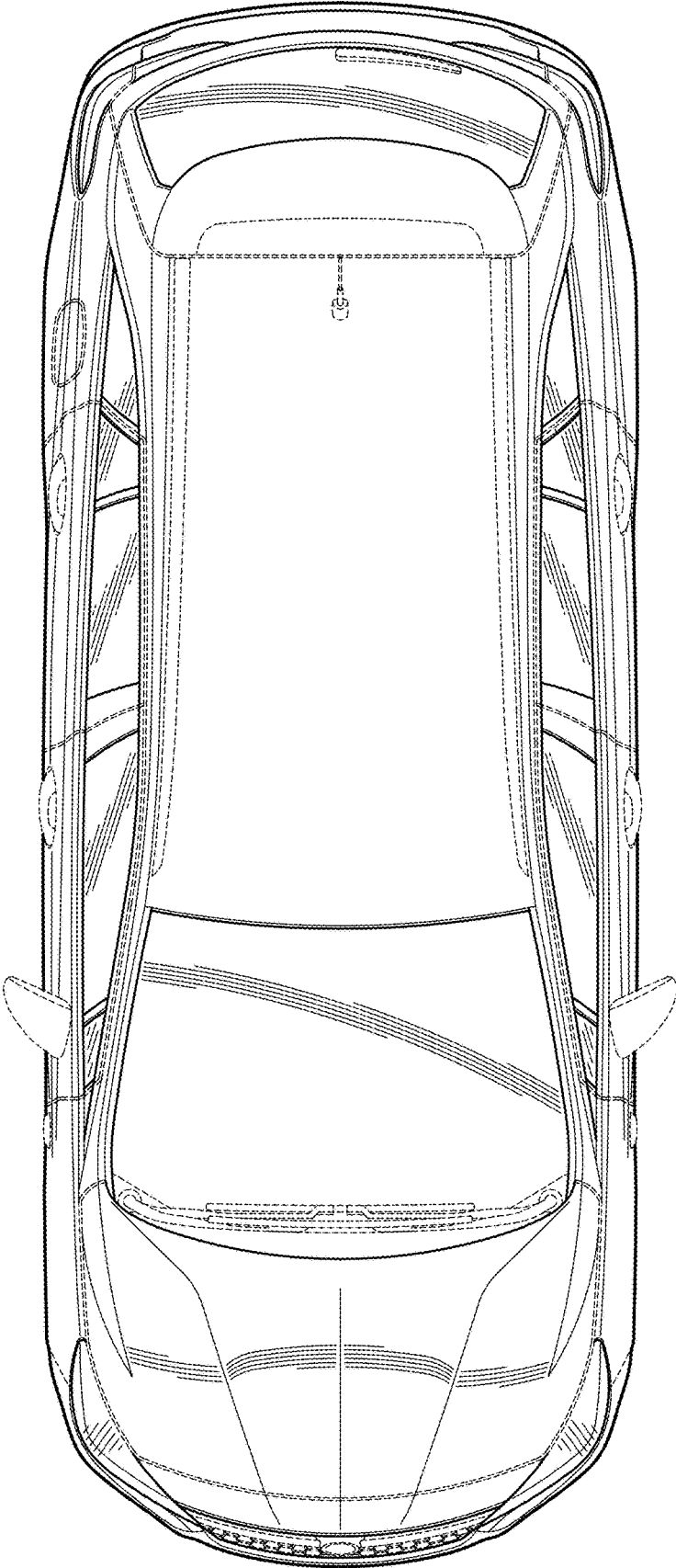

FIG. 7