



US00D650750S

(12) **United States Design Patent**
Smith et al.

(10) **Patent No.:** **US D650,750 S**

(45) **Date of Patent:** **** Dec. 20, 2011**

(54) **DUAL POWER QUAD SIGNAL BOARD-MOUNTABLE CONNECTOR**

(75) Inventors: **Nathan T Smith**, Worcester, MA (US);
Craig H Baker, Shrewsbury, MA (US)

(73) Assignee: **Anderson Power Products, Inc.**,
Sterling, MA (US)

(**) Term: **14 Years**

(21) Appl. No.: **29/368,330**

(22) Filed: **Aug. 23, 2010**

(51) **LOC (9) Cl.** **13-03**

(52) **U.S. Cl.** **D13/133**

(58) **Field of Classification Search** D13/133,
D13/146-147, 154, 156, 184; 439/180, 252,
439/278, 280, 290-293, 328, 374, 375, 378,
439/483, 488, 489, 491, 500, 525, 529, 533,
439/592-593, 680, 892, 894

See application file for complete search history.

(56) **References Cited**

U.S. PATENT DOCUMENTS

3,794,957	A *	2/1974	Winkler	439/295
6,994,595	B2 *	2/2006	Baker et al.	439/680
7,004,795	B2 *	2/2006	Mancini et al.	439/701
D519,924	S *	5/2006	Baker et al.	D13/133
D578,065	S *	10/2008	Baker et al.	D13/133

D612,807	S *	3/2010	Mancini et al.	D13/133
D615,039	S *	5/2010	Mancini et al.	D13/133
D641,700	S *	7/2011	Ohkuma	D13/133
D641,701	S *	7/2011	Ohkuma	D13/133
D642,128	S *	7/2011	Ohkuma	D13/133
D643,817	S *	8/2011	Ando et al.	D13/133

* cited by examiner

Primary Examiner — Thomas Johannes

(74) *Attorney, Agent, or Firm* — Vern Maine & Associates

(57) **CLAIM**

The ornamental design for a dual power quad signal board-mountable connector, as shown and described.

DESCRIPTION

FIG. 1 is a front view of a dual power quad signal board-mountable connector showing our new design;

FIG. 2 is a back view thereof;

FIG. 3 is a top view thereof;

FIG. 4 is a bottom view thereof;

FIG. 5 is a right side view thereof;

FIG. 6 is a left side view thereof;

FIG. 7 is a front, top perspective view thereof; and,

FIG. 8 is a back, bottom perspective view thereof.

The broken line portion of the figure drawings is included to show unclaimed subject matter only and forms no part of the claimed design.

1 Claim, 8 Drawing Sheets

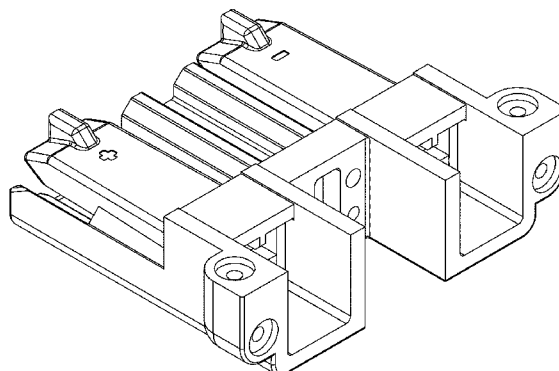
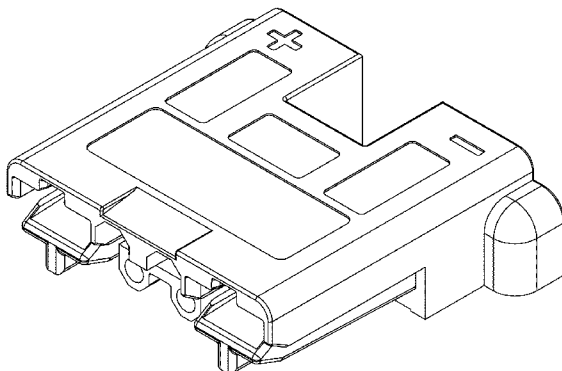

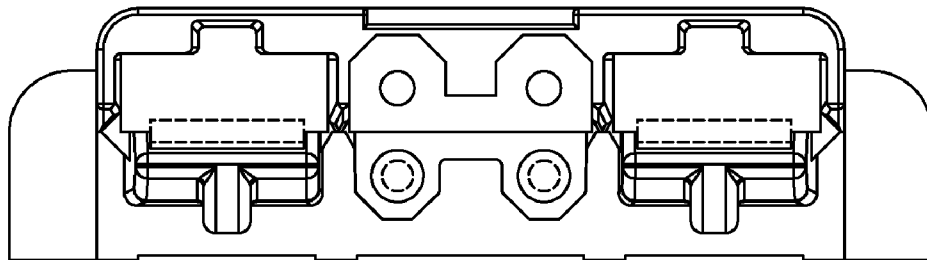

FIG. 1

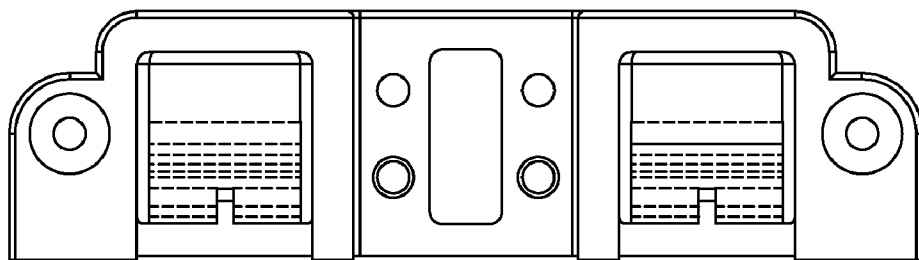

FIG. 2

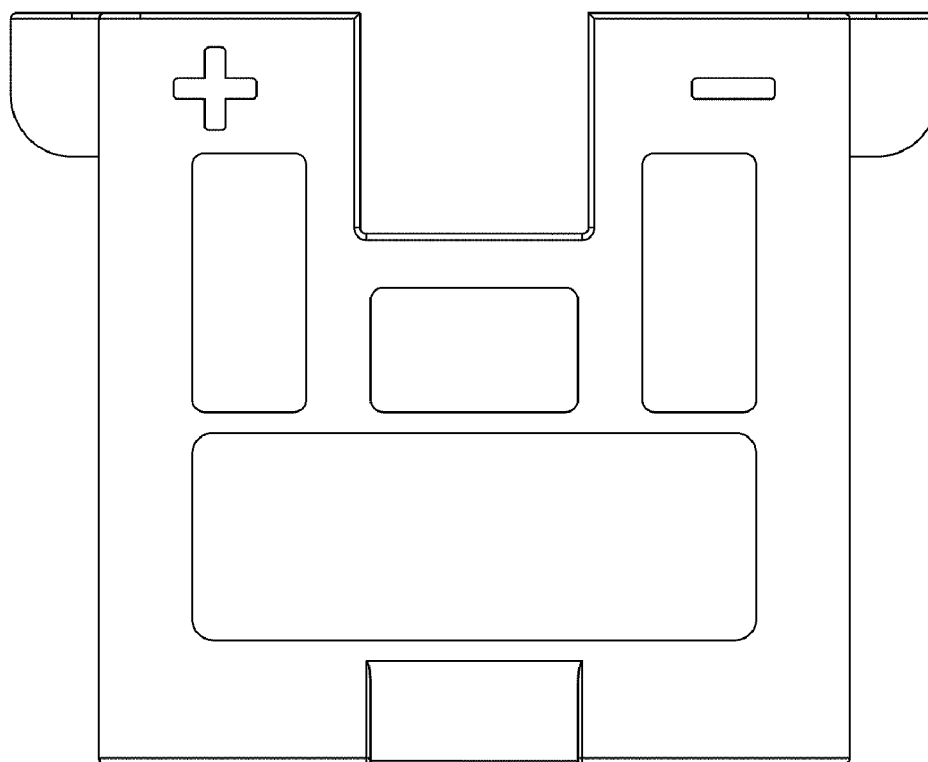

FIG. 3

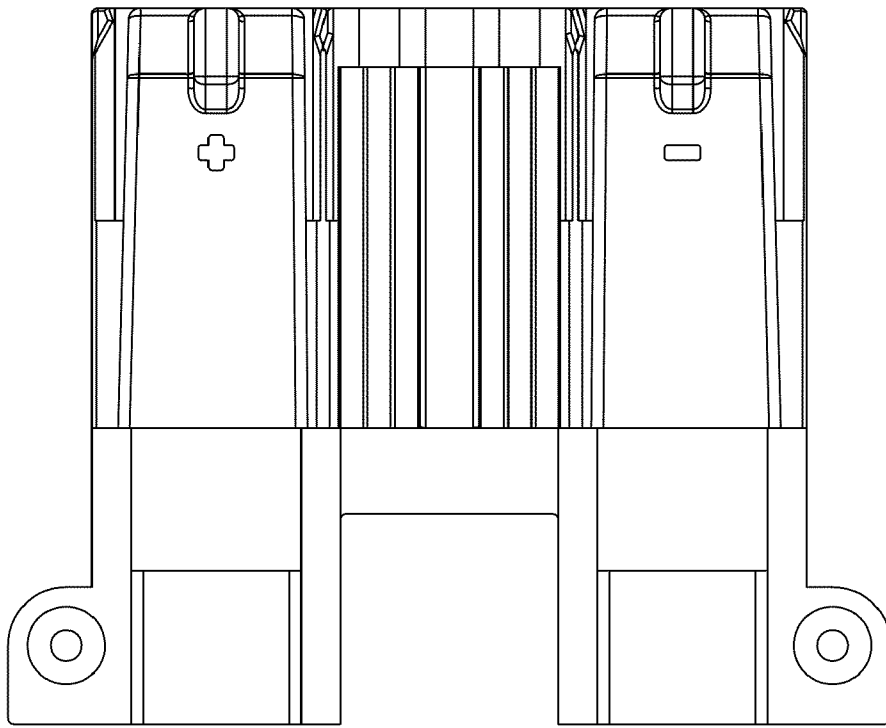

FIG. 4

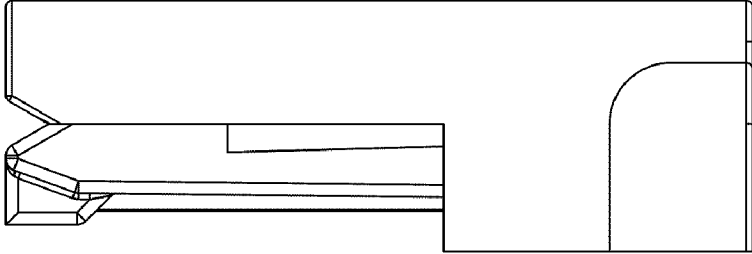

FIG. 5

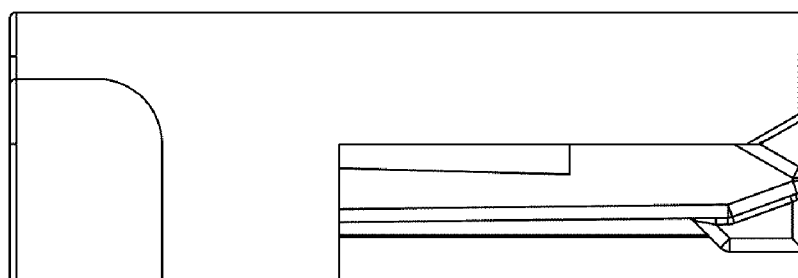

FIG. 6

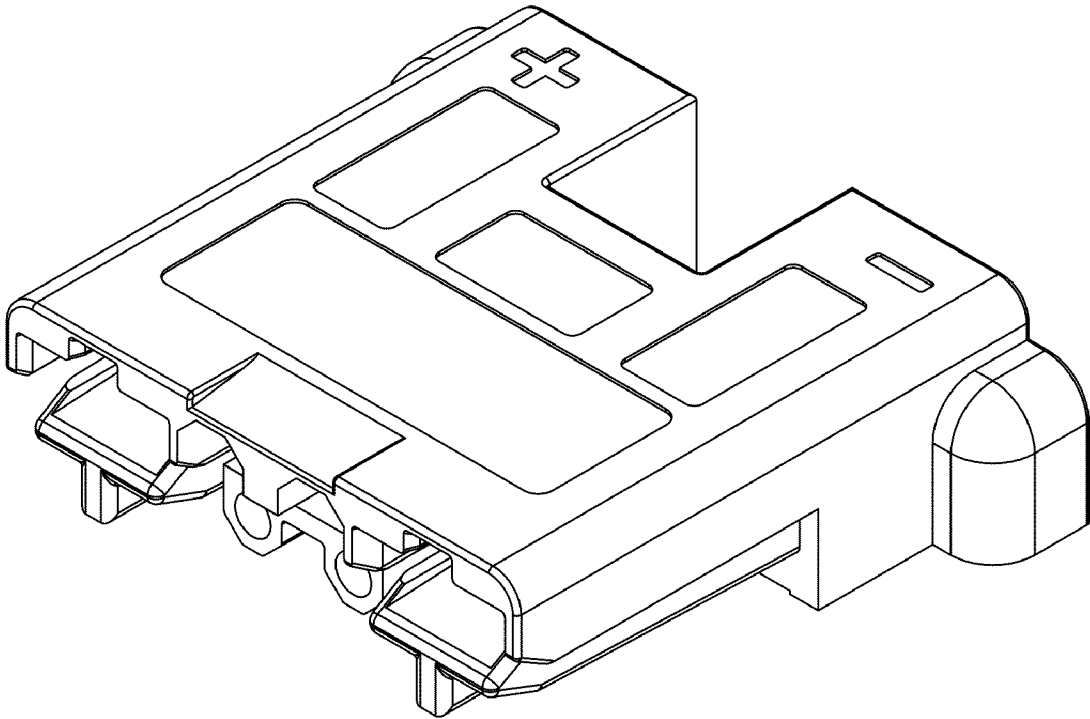

FIG. 7

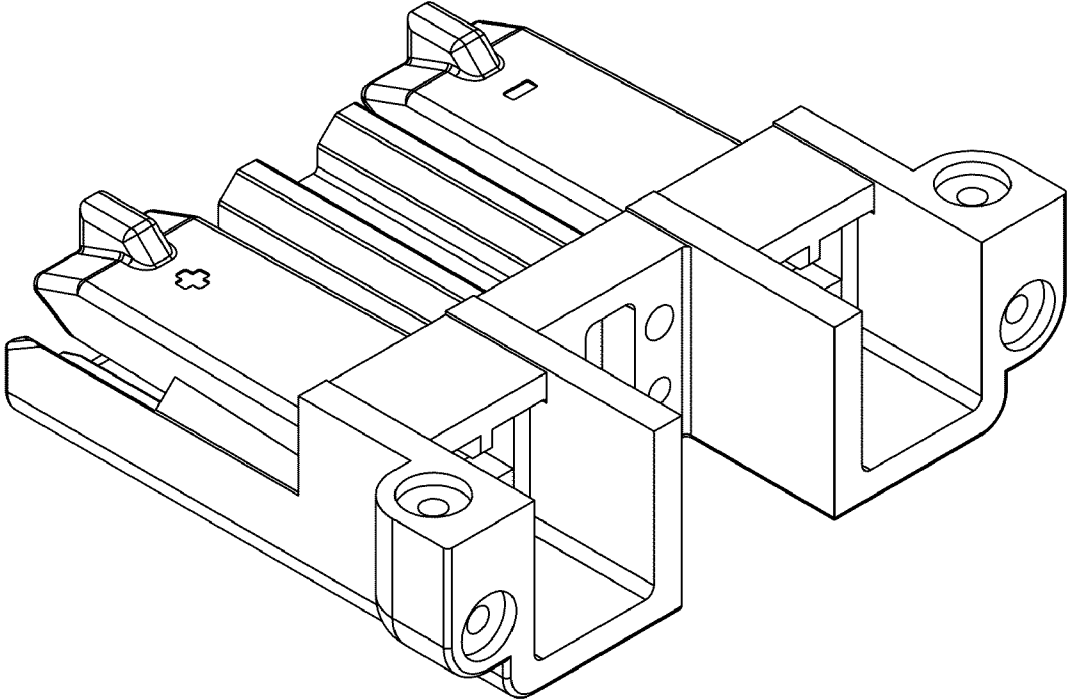

FIG. 8