

(No Model.)

3 Sheets—Sheet 1.

E. T. McKAIG.

FRAME ADAPTED FOR USE WITH VARIOUS MACHINES.

No. 361,534.

Patented Apr. 19, 1887.

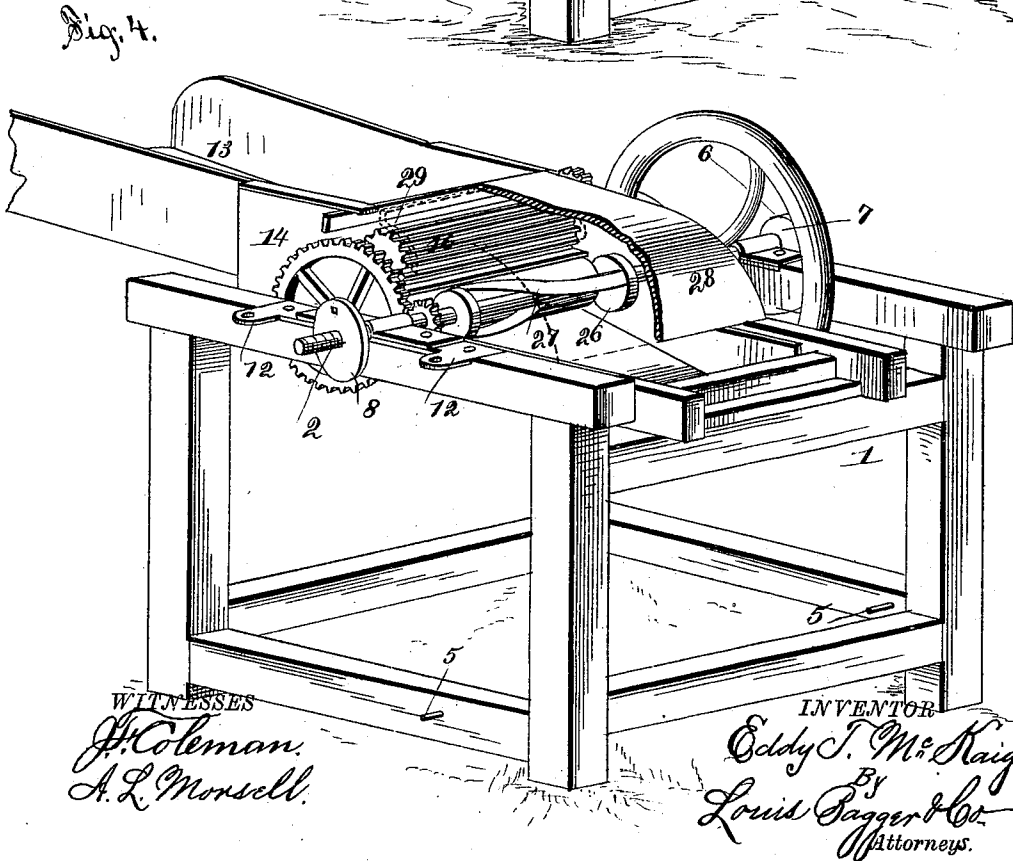
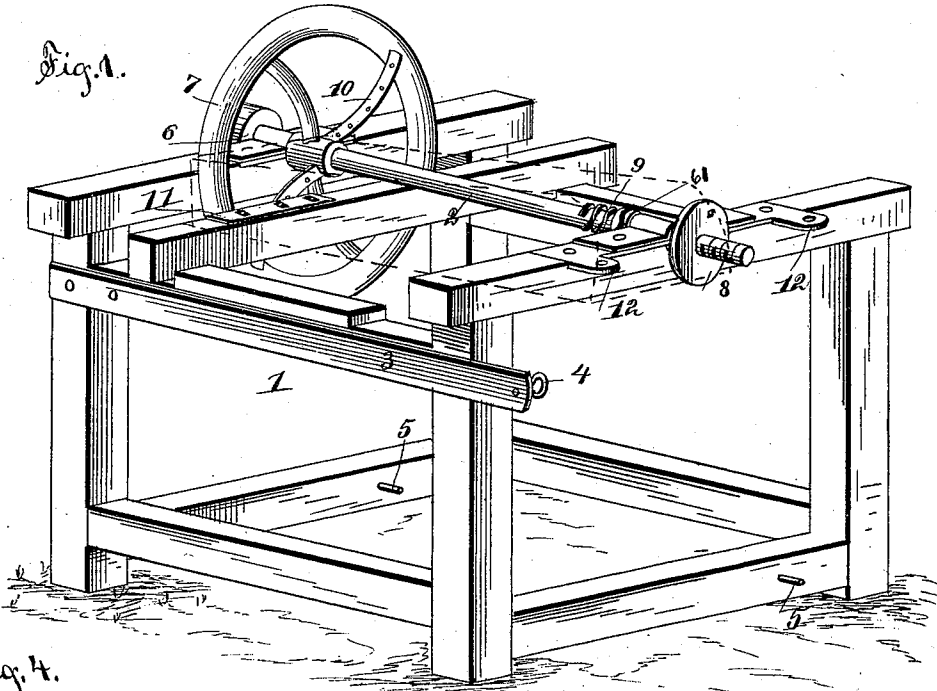

WITNESSES
H. Coleman.
A. L. Morsell.

INVENTOR
Eddy T. McKaig.
By
Louis Pagger & Co.
Attorneys.

(No Model.)

3 Sheets—Sheet 2.

E. T. McKAIG.

FRAME ADAPTED FOR USE WITH VARIOUS MACHINES.

No. 361,534.

Patented Apr. 19, 1887.

Fig. 2.

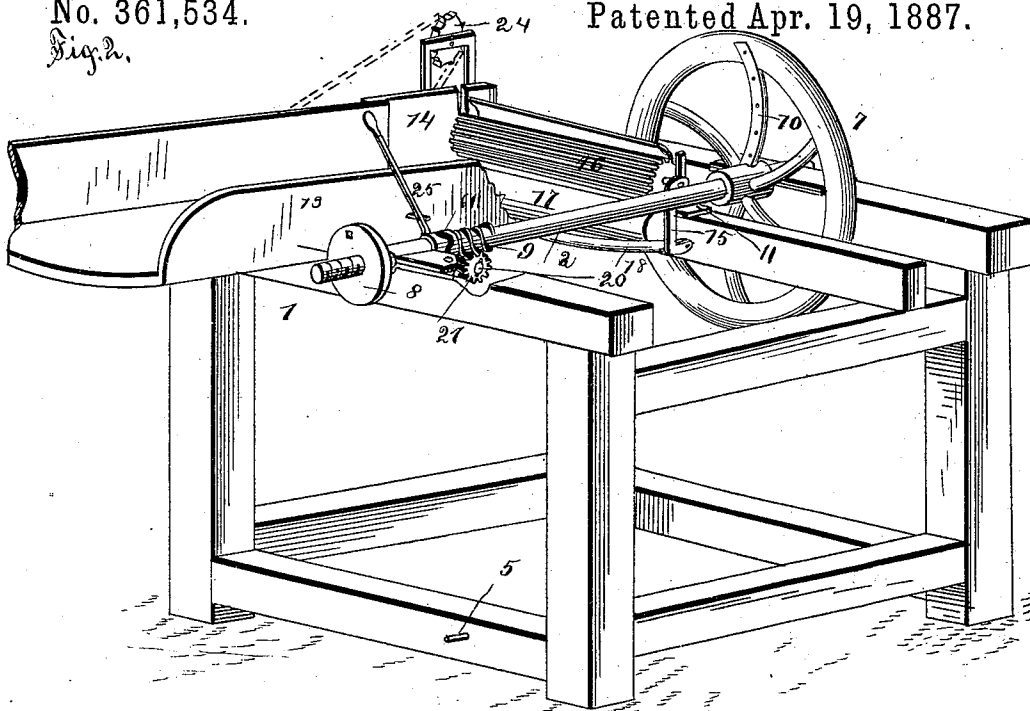
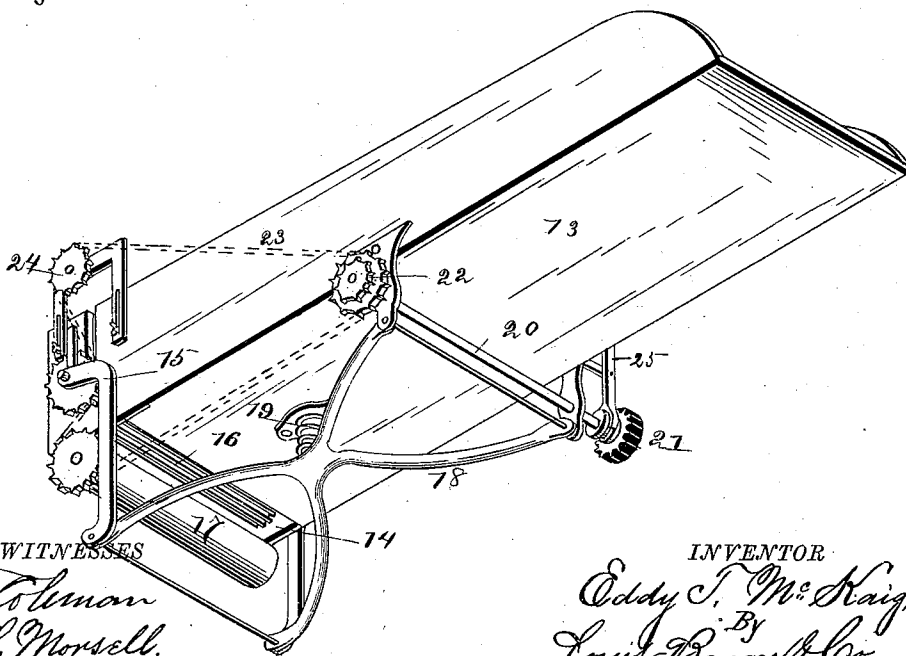

Fig. 3.



WITNESSES

J. H. Coleman
A. L. Morsell.

INVENTOR

Eddy T. McKaig
By
Louis Daggert & Co.
Attorneys.

(No Model.)

3 Sheets—Sheet 3.

E. T. McKAIG.

FRAME ADAPTED FOR USE WITH VARIOUS MACHINES.

No. 361,534.

Patented Apr. 19, 1887.

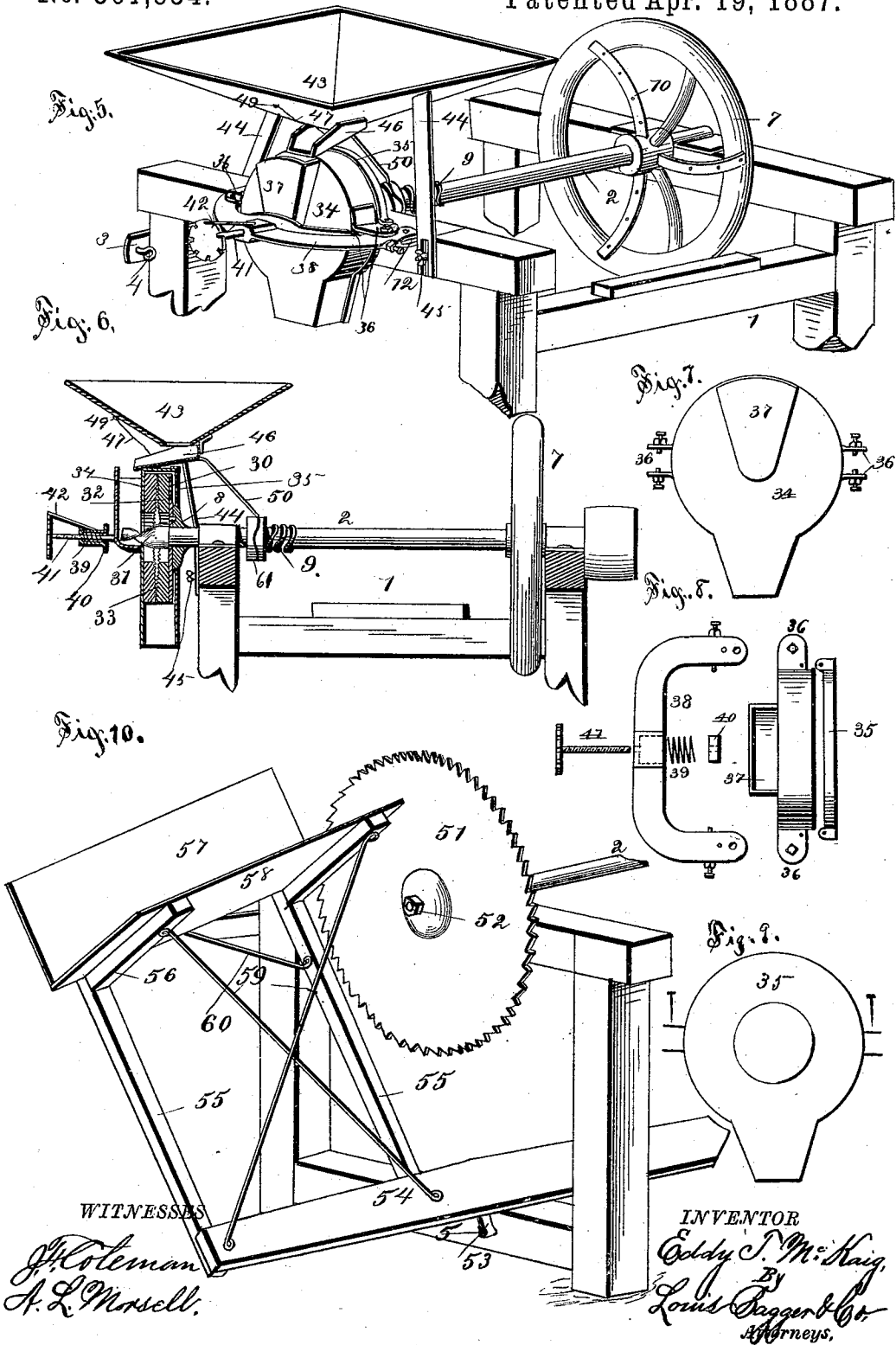

WITNESSES
J. Coleman
A. L. Masell.

INVENTOR
Eddy T. McKaig
 BY
Louis Duggan & Co.
 Attorneys.

UNITED STATES PATENT OFFICE.

EDDY THOMAS MCKAIG, OF CHICAGO, ILLINOIS.

FRAME ADAPTED FOR USE WITH VARIOUS MACHINES.

SPECIFICATION forming part of Letters Patent No. 361,534, dated April 19, 1887.

Application filed September 10, 1886. Serial No. 213,271. (No model.)

To all whom it may concern:

Be it known that I, EDDY THOMAS MCKAIG, a citizen of the United States, and a resident of Chicago, in the county of Cook and State of Illinois, have invented certain new and useful Improvements in Frames Adapted for use with Various Machines; and I do hereby declare that the following is a full, clear, and exact description of the invention, which will enable others skilled in the art to which it appertains to make and use the same, reference being had to the accompanying drawings, which form a part of this specification, and in which—

Figure 1 is a perspective view of my improved convertible frame provided with the operating shaft or arbor. Fig. 2 is a perspective view of the same as adapted for a feed-cutter. Fig. 3 is a bottom perspective view of the cutting-box. Fig. 4 is a perspective view of the frame provided with a different style of cutting mechanism, the front part of the cutting-box being broken away in this view, as also in Fig. 2, to better show the different parts. Fig. 5 is a perspective view of the frame adapted for use as a mill. Fig. 6 is a sectional view of the same. Figs. 7, 8, and 9 are detail views of parts of the same, and Fig. 10 is a perspective view of the frame as adapted for use as a wood-saw.

This invention relates to what are known as "convertible machines," in which the same general frame-work and operating mechanism are converted from one use to another by the removal and substitution of various parts pertaining more particularly to the specific use for which it is desired to be used. These convertible machines are a valuable addition to the list of machines and tools where they can be thus changed without sacrificing any of the valuable features of each separate machine, or without adding materially to the cost of either one of the machines when made for that particular use. Still another requisite is that the machines be not too complicated to be easily understood and operated by the mass of persons into whose hands they will eventually come for use, nor have too many parts to be mislaid and lost when not in use. A machine possessing these features I have invented, which consists in the improved construction and combination of parts, as will be hereinafter more fully set forth.

Referring to the accompanying drawings, in which the same figures of reference indicate corresponding parts in all the figures of the drawings, 1 represents the frame, and 2 represents the shaft journaled upon its top. Secured to one side of the frame is a spring-bar, 3, the free end of which projects slightly beyond the side, and which is provided with an eyebolt, 4. Upon two of the bottom cross-pieces of the frame are two projecting pins, 5. The shaft of the machine has a belt-wheel, 6, and fly-wheel 7 secured upon one end and a collar, 8, near the other, the portion of the shaft projecting beyond the collar being screw-threaded, and at its intermediate portion it is provided with a worm, 9, at one end of which is an eccentric groove, 61. The spokes of the fly-wheel are preferably made in a curve, with each alternate one flush with the inner part of the rim, and provided with curved blades 10, and the other spokes set back nearer the other part of the rim. A slotted cutting-plate, 11, is secured to one of the top cross-pieces of the wheel carrying the knives. By means of the slots the outer edge of the plate can be placed very close to the knives upon the spokes, so that whatever projects beyond the edge of the plate will be cut off by the revolving knives. The lower half of the bearing for the shaft 2 at the opposite side of the frame is longer than the top part, and provided with a perforated lip, 12, at each end. If desired, however, two perforated plates can be secured to the top of the frame at those points instead. This much of the frame and its attachments remain the same and are not needed to be changed in converting it from one machine to another. When it is desired to convert it into either a feed-cutter, a mill, or a saw, it is only necessary to attach the few parts relating to that machine at their appropriate places and use the machine the same as though it was made expressly for that purpose.

If it is desired to use it as a fodder-cutter, a cutting-box, 13, is bolted to the frame with one end near to the fly-wheel 7 and the other end to the opposite side of the frame. The end of the box which is over the plate is made of iron, or provided with the iron plates 14 at its sides, having vertical slots from their tops. A hanger, 15, moves in these slots and has a

roller, 16, secured in its upper ends, a similar roller, 17, being journaled in bearings in the lower edge of the plates 14, one end of each of said rollers being provided with a sprocket-wheel. Hinged to the lower end of the hanger 15 is one end of an equalizer, 18, the other end of which is pivoted to the lower side of the box nearer its rear end, and intermediate the ends of this equalizer is a spring, 19, which bears against the lower part of the box and presses the hanger downward, thus causing the feed-rollers 16 and 17 to bear against each other with force sufficient to carry the fodder to the knives on the fly-wheel, and at the same time will permit different-sized bunches to pass through without damaging the mechanism.

Across the rear portion of the box 13 is a shaft, 20, one end of which is provided with a pinion, 21, which engages with the worm-gear on the shaft 2 and the other end with a sprocket-wheel, 22, by means of which motion is conveyed to the feed-rollers by means of a sprocket-chain, 23. For the purpose of varying the length of cut, the feed-rollers are made to travel at different rates of speed by having different-sized sprocket-wheels on the end of the shaft 20, so that the chain can be shifted from one to the other, as desired. To regulate the slack or tension of the chain when the changes are made from one sized sprocket-wheel to another, the chain is passed over an idler, 24, which is adjustably secured to the front end of the box by means of a slotted plate or support.

To throw the cutter in or out of gear without stopping the shaft 2, the pinion 21 is secured loosely upon the shaft 20 and has one end recessed, which engages with a pin through the shaft when in operation; but when it is out of gear the pinion is slipped back upon the shaft by means of a lever, 25, which is pivotally secured to one side of the box 13, and engages with the hub of the pinion with its shorter end.

In operation the fodder is placed in the cutting-box and passed between the feed-rollers until the ends project over the plate on top of the frame far enough to be cut off by the rapidly-revolving knives on the fly-wheel, the spokes that have no knives being set back far enough to not touch the ends of the stalks as they are being forced forward by the feed-rollers until they are cut off by the following knife.

Instead of using a wheel-cutter, as above described, a cylinder-cutter can be used, as shown in Fig. 4. In this style the cutting-box is placed at right angles to the shaft 2, which is provided with the cylinder 26, carrying the spiral knives 27, and the feed-rollers are operated by means of cog-wheels instead of sprocket-wheel and chain. A removable cap or lid, 28, is placed over the end of the box, which keeps the cut feed from scattering too much, and causes it to pass down into a chute, which delivers it to the feed-box or other vessel. In either style a curved plate, 29, is hinged to the top roller, 16, and hangs down upon the ends

of the stalks and presses them down near where they are cut by the knives.

When it is desired to convert the device into a mill for grinding feed or grain, instead of attaching the above mechanism, a disk, 30, having a lug upon its back, is secured upon the end of shaft 2, between the collar 8, which is provided with a hole or recess to receive the lug, and a nut, 31, the outer end of which is formed into a screw or spiral. Bolted to this disk is an annular grinding-plate, 32, of chilled iron or other hard metal. A corresponding annular plate, 33, is secured upon the inner side of a casing, 34, the back of which, 35, is provided with a central aperture, by means of which it is passed over the collar on the shaft before the disk 30 is secured in place. This back is secured to the casing by means of perforated lips or lugs which are secured to a pair of ears, 36, on each side of the casing by means of a bolt passing down through said lips and ears. On the front side of the casing is a throat, 37, the lower end of which incloses the outer end of the nut 31, which projects through a perforation in the casing, and from which the grain is drawn by the nut in between the grinding-plates. A yoke, 38, is secured at its ends to the lips 12, on the top of the frame, by means of bolts or pins passing through them and the lips, and passes around the casing and holds it in place. The central portion of this yoke is cored out, or provided with a recess, within which is placed a spiral or other spring, 39, and a nut, 40. A lighter screw, 41, having a hand-wheel on its outer end, passes loosely through the step and spring and engages with the threads of the nut, and bears against the outer side of the casing, or, more properly, against the lower end of the throat 37, and regulates the distance between the two grinding-plates to grind coarse or fine. The rim of this hand-wheel is provided with notches in which is placed one end of a locking-pin, 42, which is hinged to the step at the other.

Each of the ears 36 is provided with a set-screw and jam-nut, by means of which the casing is adjusted vertically in relation to the revolving grinding-plate 32, and the ends of the yoke are also provided with set-screws by means of which it is adjusted laterally. Above the mill is a hopper, 43, which is secured in position upon the legs 44, the lower ends of which are slotted and engage with thumb-nuts on the side of the frame.

Beneath the discharge-opening in the hopper is a chute, 46, which is hinged at one end to one side of the hopper, and adjustably secured at the other to the other side of the hopper by means of the ordinary strap, 47, secured in the loop or staple 49. To the rear of this chute is rigidly secured a downwardly-projecting arm or lever, 50, the lower end of which engages with the eccentric groove 61, and by means of which the chute is shaken sufficiently to cause the grain to readily pass from the hopper to

the throat of the casing. By raising and lowering the hopper by means of the slots in the lower ends of its legs the inclination of the chute is so changed as to regulate the amount of grain passing from the hopper, by reason of the fact that the lower end of the rod 50 remains in the same place and the upper end, which is secured to the chute, causes it to be changed as stated.

10 If any hard substance should accidentally be fed into the mill, the spring 39 will permit the grinding-plates to separate sufficiently for it to pass between them without breaking either one of them. In operation the plates are adjusted according to the grade of meal which it is desired to grind and the hand-wheel locked to prevent its changing. The grain is then fed into the hopper, passed down through the casing between the grinding-plates, and out into a suitable receptacle.

20 Finally, if it is desired to convert the machine into a wood-saw, a circular saw, 51, is secured against the collar 8 by a nut, 52, a washer being interposed between the nut and saw, if desired. A rocking table is hinged to the lower cross-pieces of the frame by means of loop-eyes or hinges 53 upon the under side of a beam, 54, which engage with the pins 5, and upon which it rocks or swings. The outer end of this beam projects far enough to one side of the frame to permit the table to be moved back and forth past the end of the shaft carrying the saw. The table proper consists of two upright posts, 55, near the top of which projects the bottom supports, 56, of the table. Secured to the tops of the posts 55 and the arms 56 is a back of the table 57 and the bottom 58. Suitable cross-braces, 59, support the outer ends of the arms 56. A rod, 60, is connected at one end to one of the posts 55, and at the other end is hooked into the eyebolt 4 at the end of the

spring-bar 3. One of the pins 5 may be provided with a colter or other means for keeping the hinges from coming off while in use. In operation a piece of wood is placed on the board or bottom 58 and against the back 57 and pushed against the saw by the operator. When the stick is cut in two, the spring-bar 3 at the side of the frame will push the table back into its former position.

50 Having thus described my invention, I claim—

1. A frame adapted to be used in connection with various machines, comprising uprights and cross-pieces, a shaft journaled across its top having a fly-wheel and belt-wheel secured to one end, a collar at the other end, an eccentric groove and a worm-gear at its intermediate portion, a spring-bar secured to one side of said frame, two pins on its bottom cross-bars, a slotted plate secured to one of its top cross-pieces, and two lips on its other top cross-piece, said frame and shaft being adapted to receive suitable attachments for converting the same into specific machines.

65 2. The combination of a frame, a shaft journaled across its top, a grinding-plate secured to one end of said shaft, a casing having a grinding-plate upon its interior, and a pair of ears upon each side, a set-screw and jam-nut in each of said ears, a yoke cored out or provided with a recess at its central portion and provided with a set-screw near each end, a nut and a spring in said recess, and a lighter screw.

70 In testimony that I claim the foregoing as my own I have hereunto affixed my signature in presence of two witnesses.

EDDY THOMAS MCKAIG.

Witnesses:

B. B. HUMPHREY,
JOS. H. WEBSTER.