



- (51) **International Patent Classification:**
H04W 74/00 (2009.01) *H04L 12/70* (2013.01)
- (21) **International Application Number:**
PCT/CN2013/083557
- (22) **International Filing Date:**
16 September 2013 (16.09.2013)
- (25) **Filing Language:** English
- (26) **Publication Language:** English
- (30) **Priority Data:**
61/701,369 14 September 2012 (14.09.2012) US
61/709,679 4 October 2012 (04.10.2012) US
14/027,040 13 September 2013 (13.09.2013) US
- (71) **Applicant: HUAWEI TECHNOLOGIES CO., LTD.**
[CN/CN]; Huawei Administration Building, Bantian, Longgang, Shenzhen, Guangdong 518129 (CN).
- (72) **Inventors: KAIPPALLIMALIL, John;** 3260 Heatherbrook Ln., Richardson, Texas 75082 (US). **AL-SHALASH, Mazin;** 12014 Jereme Trail, Frisco, Texas 75035 (US). **XIANG, Zhixian;** 6301 Stonewood Dr.Apt 3004, Plano, Texas 75024 (US).
- (81) **Designated States** (*unless otherwise indicated, for every kind of national protection available*): AE, AG, AL, AM, AO, AT, AU, AZ, BA, BB, BG, BH, BN, BR, BW, BY,

BZ, CA, CH, CL, CN, CO, CR, CU, CZ, DE, DK, DM, DO, DZ, EC, EE, EG, ES, FI, GB, GD, GE, GH, GM, GT, HN, HR, HU, ID, IL, IN, IS, JP, KE, KG, KN, KP, KR, KZ, LA, LC, LK, LR, LS, LT, LU, LY, MA, MD, ME, MG, MK, MN, MW, MX, MY, MZ, NA, NG, NI, NO, NZ, OM, PA, PE, PG, PH, PL, PT, QA, RO, RS, RU, RW, SA, SC, SD, SE, SG, SK, SL, SM, ST, SV, SY, TH, TJ, TM, TN, TR, TT, TZ, UA, UG, US, UZ, VC, VN, ZA, ZM, ZW.

- (84) **Designated States** (*unless otherwise indicated, for every kind of regional protection available*): ARIPO (BW, GH, GM, KE, LR, LS, MW, MZ, NA, RW, SD, SL, SZ, TZ, UG, ZM, ZW), Eurasian (AM, AZ, BY, KG, KZ, RU, TJ, TM), European (AL, AT, BE, BG, CH, CY, CZ, DE, DK, EE, ES, FI, FR, GB, GR, HR, HU, IE, IS, IT, LT, LU, LV, MC, MK, MT, NL, NO, PL, PT, RO, RS, SE, SI, SK, SM, TR), OAPI (BF, BJ, CF, CG, CI, CM, GA, GN, GQ, GW, KM, ML, MR, NE, SN, TD, TG).

Declarations under Rule 4.17:

- *as to the applicant's entitlement to claim the priority of the earlier application (Rule 4.17(iii))*

Published:

- *with international search report (Art. 21(3))*

(54) **Title:** SYSTEM AND METHOD FOR A MULTIPLE IP INTERFACE CONTROL PROTOCOL

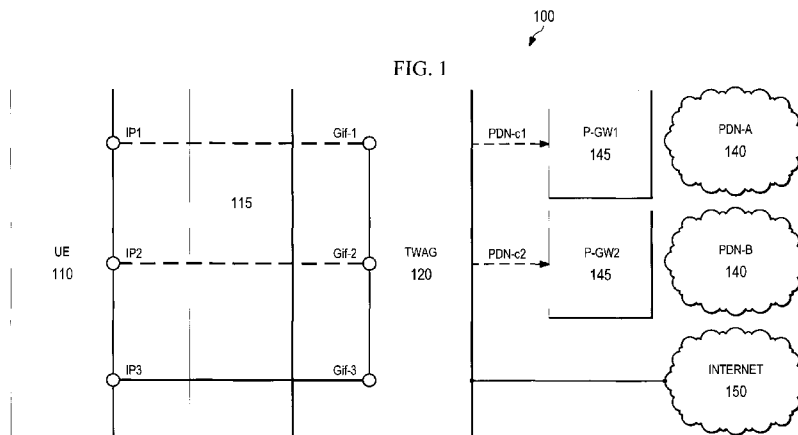

(57) **Abstract:** Embodiments are provided for a mechanism for supporting multiple 3GPP Packet Data Network (PDN) connections over a WLAN. Multiple gateway interfaces, each corresponding to a different PDN, are established over a single connection, via the WLAN, between a UE and an access gateway. A PDN access configuration protocol (PACP) is provided to configure the association between the IP interface on the access gateway and the corresponding 3GPP PDN/APN connection, and exchange the PDN setup between the UE and the access gateway. The PACP mechanisms allow signaling APN information and associating corresponding IP context at the access gateway, setting up and tearing down connection context between the UE and PDN gateway (P-GW), and supporting session continuity when the UE moves to another access gateway. The mechanisms support using Dynamic Host Configuration Protocol (DHCP) for IPv4 and Neighbor Discovery for IPv6.

WO 2014/040564 A1

System and Method for a Multiple IP Interface Control Protocol

[0001] This application claims the benefit of U.S. Provisional Application No. 61/701,369 filed on September 14, 2012, and entitled “System and Method for a Multiple IP Interface Control Protocol,” and U.S. Provisional Application No. 61/709,679 filed on October 4, 2012, entitled “System and Method for Multiple Interface Control Protocol Initialization,” and U.S. Non-Provisional Application No. 14/027,040, filed on September 13, 2013, entitled “System and Method for a Multiple IP Interface Control Protocol,” which are hereby incorporated herein by reference as if reproduced in their entirety.

TECHNICAL FIELD

[0002] The present invention relates to the field of wireless communications, and, in particular embodiments, to a system and method for a multiple Internet Protocol (IP) interface control protocol.

BACKGROUND

[0003] User access to 3GPP Enhanced Packet Core (EPC) is supported over networks, such as a wireless local access network (WLAN), using Dual Stack Mobile IP (DSMIP) or Internet Key Exchange/Internet Protocol Security (IKE/IPSec) to provide a “connection oriented” interface that corresponds to a 3GPP Packet Data Network (PDN). 3GPP Release 11 specifications 23.402 (chapter 16) describes how a user in a trusted WLAN can attach and obtain services from the operator’s EPC network. However, in Release 11, only connections to a single PDN are supported over a WLAN. It is desirable to support more than one PDN connection over the WLAN, for instance to achieve some parity between 3GPP and WLAN access in terms of the connection service model.

SUMMARY OF THE INVENTION

[0004] In accordance with an embodiment, a method implemented by a network component for supporting Packet Data Network (PDN) connections over a wireless access network includes receiving, from a user equipment (UE), a request to create a session associated with a PDN connection. The request indicates an Access Point Name (APN). The method further includes assigning a gateway Internet Protocol (IP) interface on a link between the UE and the network component, sending, to the UE, an acknowledgement to create a session, the acknowledgement including the gateway IP interface. Further, a request for establishing the PDN connection is sent

to PDN gateway, and a response including an assigned IP address for the session is then received from the receiving from the PDN gateway.

[0005] In accordance with another embodiment, a method implemented by a UE using a dedicated protocol for supporting PDN connections over a wireless access network includes sending, to an access gateway, a request to create a session associated with a PDN connection. The request indicates an APN. The UE then receives, from the access gateway, an acknowledgement to create a session including a gateway IP interface assigned by the access gateway on a link between the UE and the access gateway. The method further includes sending, to the access gateway, a Dynamic Host Configuration Protocol (DHCP) request for associating the gateway IP interface with the PDN connection, and receiving, from the access gateway, a DHCP acknowledgement including an assigned IP address forwarded by a PDN gateway to the access gateway.

[0006] In accordance with another embodiment, an access gateway supporting PDN connections over a wireless access network includes at least one processor and a non-transitory computer readable storage medium storing programming for execution by the at least one processor. The programming including instructions to receive, from a UE, a request to create a session associated with a PDN connection. The request indicates an APN. The programming further configure the access gateway to assign a gateway IP interface on a link between the UE and the access gateway, and send, to the UE, an acknowledgement to create a session, the acknowledgement including the gateway IP interface. The access gateway is further configured to send, to a PDN gateway, a request for establishing the PDN connection, and receive, from the PDN gateway, a response including an assigned IP address for the session.

[0007] In accordance with yet another embodiment, a UE supporting PDN connections over a wireless access network includes at least one processor and a non-transitory computer readable storage medium storing programming for execution by the at least one processor. The programming includes instructions to send, to an access gateway, a request to create a session associated with a PDN connection. The request indicating an APN. The programming includes further instructions to receive, from the access gateway, an acknowledgement to create a session including a gateway IP interface assigned by the access gateway on a link between the UE and the access gateway. The UE is also configured to send, to the access gateway, a DHCP request for associating the gateway IP interface with the PDN connection, and receive, from the access gateway, a DHCP acknowledgement including an assigned IP address forwarded by a PDN gateway to the access gateway.

[0008] The foregoing has outlined rather broadly the features of an embodiment of the present invention in order that the detailed description of the invention that follows may be better understood. Additional features and advantages of embodiments of the invention will be described hereinafter, which form the subject of the claims of the invention. It should be appreciated by those skilled in the art that the conception and specific embodiments disclosed may be readily utilized as a basis for modifying or designing other structures or processes for carrying out the same purposes of the present invention. It should also be realized by those skilled in the art that such equivalent constructions do not depart from the spirit and scope of the invention as set forth in the appended claims.

BRIEF DESCRIPTION OF THE DRAWINGS

[0009] For a more complete understanding of the present invention, and the advantages thereof, reference is now made to the following descriptions taken in conjunction with the accompanying drawing, in which:

[0010] Figure 1 illustrates a PDN connection model according to an embodiment of the disclosure;

[0011] Figure 2 illustrates a nodal model according to an embodiment of the disclosure;

[0012] Figure 3 illustrates an embodiment scheme for IPv4 interface configuration;

[0013] Figure 4 illustrates an embodiment scheme for IPv6 interface configuration;

[0014] Figure 5 illustrates an embodiment scheme for a graceful detach;

[0015] Figure 6 illustrates an embodiment scheme for IPv4 handover;

[0016] Figure 7 illustrates an embodiment scheme for IPv6 handover;

[0017] Figure 8 illustrates another embodiment scheme for IPv4 interface configuration;

[0018] Figure 9 illustrates another embodiment scheme for IPv6 interface configuration;

[0019] Figure 10 is a diagram of an exemplary processing system that can be used to implement various embodiments.

[0020] Corresponding numerals and symbols in the different figures generally refer to corresponding parts unless otherwise indicated. The figures are drawn to clearly illustrate the relevant aspects of the embodiments and are not necessarily drawn to scale.

DETAILED DESCRIPTION OF ILLUSTRATIVE EMBODIMENTS

[0021] The making and using of the presently preferred embodiments are discussed in detail below. It should be appreciated, however, that the present invention provides many applicable inventive concepts that can be embodied in a wide variety of specific contexts. The specific embodiments discussed are merely illustrative of specific ways to make and use the invention, and do not limit the scope of the invention.

[0022] Embodiments are provided herein for a mechanism for supporting multiple 3GPP PDN connections over a WLAN. The embodiments enable multiple IP connections over a WLAN to corresponding PDNs and/or Access Point Name (APNs) over a single layer Media Access Control (MAC) link. Multiple gateway interfaces, each corresponding to a different PDN, can be established over a single connection (via the WLAN) between a user equipment (UE) and an access gateway. A PDN access configuration protocol (PACP) is provided to configure the association between the IP interface on the access gateway and the corresponding 3GPP PDN/APN connection, and exchange the PDN setup between the UE and the access gateway. The PACP mechanisms allow signaling APN information and associating corresponding IP context at the access gateway, setting up and tearing down connection context between the UE and PDN gateway (P-GW), and supporting session continuity when the UE crosses to another access gateway. The mechanisms support using Dynamic Host Configuration Protocol (DHCP) for IP version 4 (IPv4) and Neighbor Discovery for IP version 6 (IPv6), and are compatible with 3GPP Release 11 specification 23.402 (chapter 16) methods for setting up a single connection.

[0023] Figure 1 illustrates a PDN connection model 100 according to an embodiment of the disclosure. A UE 110 attaches to a P-GW 145 in a 3GPP EPC via a WLAN access point (AP) 115 and an access gateway 120, referred to as a trusted wireless access gateway (TWAG). The UE may be any user operated mobile or personal communications/computer device, such as a desktop computer, a laptop computer, a tablet computer, a smartphone, or set-top box, or other devices. The access gateway 120 is the first hop router for the UE 110. The WLAN AP 115 connects the UE 110 to the access gateway 120. The access gateway 120 behaves as a Proxy Mobile IP (PMIP) mobile access gateway (MAG) and obtains IP addresses from the P-GW 145, which in turn serves as a PMIP local mobility anchor (LMA). The UE 100 can establish multiple connections, e.g., three connections, over a single link with the access gateway 120. The connections are established using a PACP, as described further below. The three connections over the link between the UE and the access gateway 120 are associated with PDN connections (PDN-c1 and PDN-c2) to PDNs 140 (PDN-A and PDN-B) via corresponding P-GWs 145 (P-

GW1 and P-GW2), and with a non-seamless WLAN offload (NSWO) connection from the access gateway 120 to the Internet or any IP network 150. Each of the connections on the single link between the UE 110 and the access gateway 120 is identified at the access gateway 120 by a gateway IP interface labeled Gif-x (Gif-1, Gif-2, Gif-3). Each gateway IP interface is derived from a virtual but unique MAC address configured in the access gateway 120. The gateway IP interface is unique for all PDN/NSWO connections of the UE 110. A connection context is unique if the combination or tuple {host IP address for connection, host MAC address, gateway IP interface for connection, gateway MAC address for connection} is unique.

[0024] Figure 2 illustrates a nodal model 200 according to an embodiment of the disclosure. The model 200 describes various elements or entities of the UE 110, a WLAN AP 115, and the access gateway 120, which are used in the model 100 as described above. The UE 110 and the access gateway 120 support Release 11 3GPP PDN connections. The UE 110 includes a connection manager 211 that communicates, via the WLAN AP 115, with a second connection manager 221 at the access gateway 120 using the PACP to establish and delete PDN connections, as described below. The connection manager 211 and 221 can also communicate using DHCP and Router Advertisement (RA)/Router Solicitation (RS) messages. The connection manager 211 is also configured to associate the gateway interface received in a DHCP acknowledgement (Ack) or Router Advertisement to each connection and the associated applications. The connection manager 221 is configured to provide a gateway interface address and associate it with a corresponding PDN/APN.

[0025] The UE 110 supports a timer based on the DHCP retransmission values for PACP retransmission values. The access gateway 120 supports multiple MAC addresses that are mapped to a single interface. The number of MAC addresses supported may be equal to the maximum number of PDN connections per UE. The access gateway derives a gateway interface IP address from the MAC address. For IPv6, a 64 bit extended unique identifier (EUI-64) may be used. For IPv4, a simpler mapping of MAC address to one of the subnet addresses of the router may be used. The access gateway is capable of multiplexing the incoming IP configuration requests based on UE MAC address and gateway IPv4 address. For IPv6, the access gateway 120 also has the ability to generate a transient multicast address and listen to the multicast address for Router Solicitation. The source (UE and PDN) of the multicast request is determined using source IPv6 Link Local Address (LLA), or MAC, and multicast destination address.

[0026] The UE 110 also includes a routing control 212 and an Extensible Authentication Protocol (EAP) client 213 for authenticating the UE 110 by interacting with an EAP proxy 222 at the access gateway 120 via an EAP authentication entity 231 at the WLAN AP 115. The EAP

client 213 supports extensions that configure a set of keys, of which one is used to generate a hash checksum of PACP messages and another is sent to the access gateway to verify the hash value/checksum. Similarly, the EAP proxy 222 supports extensions that configure a set of keys, of which one is used to generate a hash checksum of PACP messages, and another is sent to the UE to verify the hash value/checksum. The EAP authentication entity 231 and the EAP proxy 222 communicates with a corresponding local EAP transport entity 232 and 225, respectively, for EAP transport over IP, e.g., using a Remote Authentication Dial In User Service (RADIUS) protocol. The EAP proxy 222 also communicates with an Authentication, Authorization and Accounting (AAA) server or entity 226 to authenticate the UE 110. The access gateway 120 also includes a routing control entity 223 and a S2a manager for establishing General Packet Radio Service (GPRS) Tunneling Protocol (GTP)/PMIP tunnel to the P-GW in the 3GPP EPC.

[0027] In an embodiment, the PACP uses Internet Control Message Protocol (ICMP) Echo frames to carry the signal for establishing and configuring the PDN connections between the UE and the P-GWs, for deleting connections, and establishing session continuity as described below. The ICMP Echo protocol allows an arbitrary payload following the Echo message, which is used to transport the PACP frame. Since the recipient “echoes” this entire frame back, after extracting the payload, the ICMP Echo exchange provides a measure of reliability. In another embodiment, the PACP exchanges are implemented using 802.11 management frames, which provide reliable transport of management messages. The 802.11 management frames are used to transport the PACP frame to the AP. The PACP protocol can be backhauled from the AP as payload using RADIUS, Control and Provisioning of Wireless Access Points (CAPWAP), or a similar protocol.

[0028] The PACP messages include a protocol number, length indication, and a keyed hash checksum. The protocol number is a unique number that allows identification of the protocol, and the length indicates the length of the message. The protocol uses the hash keys exchanged between the UE and access gateway during the EAP-AKA authentication sequence. Both the UE and access gateway provide keys that can be used to check the hash code of messages. The messages include REQUEST, RESPONSE and NOTIFY messages, as described below. The protocol supports the following operations. A create session operation is used by the UE to request the access gateway to setup a PDN connection corresponding to the APN. In case of handover, the UE also provides the IP address used previously. In response, the access gateway provides the Gateway Interface/Router Interface to be used for the PDN gateway. This operation consists of a REQUEST/RESPONSE sequence. A delete session operation is used by the UE or the access gateway to indicate that it is tearing down the context associated with an indicated IP address/prefix. This operation uses a NOTIFY message. A session information operation is used

by the access gateway to provide session information for any session that is setup by default, for example as per 3GPP Release 11 mechanisms. The parameters of each operation can be binary encoded for efficiency.

[0029] Figure 3 illustrates an embodiment scheme 300 for IPv4 interface configuration using the PACP. The scheme 300 is used to establish a PDN connection between a UE and a P-GW and a corresponding or IPv4 connection or association between the UE and the access gateway. The connection setup sequence includes first authenticating the UE, using EAP and Authentication Key Agreement (AKA') and setting up keys to be used in the PACP control signaling. Following this, the UE obtains a link-local address and uses this interface to setup the PDN connection. At step 0, the UE authenticates to the network (using EAP-AKA') and exchanges a key, which are used later in checking hashed integrity values of the PACP messages from the UE and access gateway. Following authentication, the UE configures a link-local IPv4 address to use for signaling the PDN connection setup using ICMP Echo or other User Datagram Protocol (UDP) binary transport. To confirm that the address is unique, the UE sends an Address Resolution Protocol (ARP) probe message or request to the access gateway. At step 1, on trigger to set up a connection for APN-x, the UE sends a PACP request to create a connection context, using a PACP operation request/create message. The access gateway echoes the message back (according to ICMP Echo) after extracting the PACP payload, and also pipes the content of the message to a connection handler for processing.

[0030] At step 2, the connection handler in the access gateway processes the PACP create message and returns, using a PACP operation acknowledge/create message, a gateway IP interface for the connection that is unique to the UE. The value of the gateway IP interface is sent in a router interface/server identifier (ID) since both the DHCP server and access gateway is the same network node in this architecture. The UE echoes the ICMP Echo response back to the access gateway. At step 3, in parallel with sending the response in step 2, the access gateway looks up the PDN gateway address associated with the APN. This exchange may include a DNS request. The access gateway constructs a GTP Create Session request or a PMIP proxy binding update (PBU) message with the parameters the UE requested in the PACP create session message in step 1. At step 4, the PDN gateway (P-GW) creates the session and replies with GTP Create Session Response/PMIP proxy binding acknowledgement (PBA) and the IP address for the PDN connection. At step 5, the UE constructs a DHCP Request with server identity set to the value received in step 2. At step 6, the access gateway processes the DHCP Request and associates it with the APN received in step 1, e.g., APN-x, and returns the IP address configured

for this PDN connection. The IP interface is now configured and ready for use. Figure 3 also shows steps 1' to 6' for setting up similarly a second PDN connection for the UE.

[0031] The sequence above describes this connection setup using ICMP Echo for transporting PACP. Following the setup of the first PDN connection, the UE may deprecate the link local address. Any of the available IPv4 connections may be used for PACP signaling. If 802.11 management frames are used to transport PACP instead of ICMP Echo, setting up an IPv4 link local interface for the initial signaling is not necessary. In an alternative implementation, instead of a gateway IP address, a gateway MAC address may be configured to the UE in step 2. In this case, the DHCP Request is sent with multicast IP address, but with the unicast gateway MAC address configured for this PDN. The gateway associates this MAC address (and UE source MAC) to the APN/PDN.

[0032] Figure 4 illustrates an embodiment scheme 400 for IPv6 interface configuration using the PACP. The scheme 400 is used to establish a PDN connection between a UE and a P-GW and a corresponding IPv6 connection between the UE and the access gateway. The connection setup sequence is similar to the scheme 300 for IPv4. At step 0, the UE authenticates to the network (using EAP-AKA') and exchanges a key for use later in checking hashed integrity values of the PACP messages from UE and access gateway. Following authentication, the UE configures a link-local IPv6 address, e.g., using the process in Neighbor Discovery for IPv6. At step 1, on trigger to set up a connection for APN-x, the UE sends a PACP request to create a connection context, using a PACP operation request/create message. The access gateway echoes the message back, and pipes the content of the message to a connection handler for processing.

[0033] At step 2, the connection handler in the access gateway processes the PACP create message and returns, using a PACP operation acknowledge/create message, a router interface and IP Gateway interface for the connection that is unique to the UE. The router interface is a transient multicast address that the access gateway listens to. The UE echoes the ICMP Echo response back to the access gateway. At step 3, in parallel with sending the response in step 2, the access gateway looks up the PDN gateway (P-GW) address associated with the APN (this may include DNS request). The access gateway constructs a GTP Create Session request or a PMIP PBU message with the parameters the UE requested in the PACP create-session. At step 4, the PDN gateway creates the session and replies with GTP Create Session Response/PMIP PBA and the IPv6 prefix for the PDN connection. At step 5, the UE may optionally constructs a Router Solicitation with destination address set to the value received of router interface in step 2. At step 6, the access gateway sends a Router Advertisement with IPv6 prefix for the PDN connection obtained in step 4, and a source address set to the gateway address value sent in step

2. The IPv6 interface is now configured and ready for use. Figure 4 also shows steps 1' to 6' for setting up similarly a second PDN connection for the UE.

[0034] The sequence above describes this connection setup using ICMP Echo for transporting PACP. Alternatively, 802.11 management frames can be used. In this case, using the IPv6 link local interface for the PACP signaling is not necessary. In another implementation, instead of a transient multicast address, a gateway MAC address can be configured to the UE in step 2. In this case, if the Router Solicitation is sent, the destination address can be the All-routers-multicast address, but the destination Layer 2 address is the unicast gateway MAC address configured for this PDN. The gateway associates this MAC address (and UE source LLA/MAC) to the APN/PDN.

[0035] Figure 5 illustrates an embodiment scheme 500 for a graceful detach of a UE's PDN connection using PACP. The scheme 500 outlines a general sequence for deleting a connection. Since there may be more than one connection active on an access link to the UE, deletion of a connection does not necessarily mean detachment of the link between the UE and the access gateway. Two connection deletion operations are supported: a network initiated connection release and a user initiated connection release. For the network initiated connection release, the trigger to detach an APN/PDN connection comes from the network, e.g., based on operator decision. The access gateway notifies the UE using a PACP notify/delete session, in step 1. This includes sending to the UE a PACP operation notify/delete session. When the UE receives the message, it echoes the message back and cleans up the local connection resources. The access gateway then signals the PDN-GW (P-GW) to release the connection resources in step 2, and receives a response in return in step 3.

[0036] For the user initiated connection release, the trigger to detach an APN/PDN connection is from the UE, e.g., when an application on the UE is closed. The UE notifies the access gateway using PACP notify/delete-session in step 1. This includes sending to the access gateway a PACP operation notify/delete session. When the access gateway receives the message, it echoes it back. The access gateway then signals the PDN-GW (P-GW) to release the connection resources in step 2, and receives a response in return in step 3. The access gateway also releases its own connection resources. The UE may release its local connection resources on receipt of the echoed message in step 1.

[0037] Figure 6 illustrates an embodiment scheme 600 for IPv4 handover using PACP, which ensures UE session continuity. This scheme 600 supports session continuity between multiple APs connected to the same access gateway and cases where the access gateway are

changed. For instance, when the UE moves to a new AP, it may discover that the same access gateway is used due to Layer 2 signaling, authentication, and/or by sending an ARP Requests to the gateway. When the access gateway is new, the UE needs to perform authentication before attaching. The UE may request for the same IP address/prefix that was used previously using the PACP signaling.

[0038] Step 0 in the sequence for session continuity with IPv4 address is similar to initial establishment of connections in scheme 300, including EAP-AKA and local-link establishment, followed by signaling to setup the PDN connection. In step 1 of scheme 600, in the PACP request to create session, an IP address (labeled IP1) corresponding to the previously assigned IP address is sent from the UE to the new access gateway, AG2. In step 2, the new access gateway, AG2, replies to the UE with a new router/server identity, and in steps 3 and 4 sends a request to the PDN-GW to allocate address IP1 for the PDN connection. The rest of the connection sequence, in steps 5 and 6, is the similar to initial attachment in scheme 300. Following setting up the PDN connection, the UE may delete the old connection using DHCP Release or PACP delete operations, in step 7, similar to scheme 500. The old access gateway, AG1, cleans up the connections and releases the PDN in steps 8 and 9, e.g., if the UE is a single radio host that breaks the old connections without a proper detach.

[0039] Figure 7 illustrates an embodiment scheme 700 for IPv6 handover, which ensures UE session continuity. Step 0 in the sequence for session continuity with IPv6 prefix is similar to initial establishment of connections in scheme 400, including EAP-AKA and local-link establishment, followed by signaling to setup the PDN connection. In step 1, in the PACP request to create-session, an IPv6 prefix (labeled PFX-1) corresponding to the previously assigned IPv6 prefix is sent from the UE to the new access gateway, AG2. In step 2, the new access gateway, AG2, replies to the UE with a new router/server identity, and in steps 3 and 4 sends a request to the PDN-GW to allocate address PFX-1 for the PDN connection. The rest of the connection sequence, in steps 5 and 6, is similar to initial attachment in scheme 400. Following setting up the PDN connection, the UE may delete the old connections using PACP delete operations, in step 7, similar to scheme 500. Unlike DHCP/IPv4, IPv6 stateless configuration does not have an explicit release message with the semantics to realize immediate connection release. The old access gateway, AG1, cleans up the connections and releases the PDN in steps 8 and 9, e.g., if the UE is a single radio host that breaks the old connections without a proper detach.

[0040] Figure 8 illustrates another embodiment scheme 800 for IPv4 interface configuration. The scheme 800 is similar to the scheme 300. However, in the scheme 800, the UE further sets

up a link local address after it has successfully authenticated with the network. At that point the access gateway (e.g., TWAG) sends to the UE a message from the router or gateway interface address to which subsequent PACP messages can be sent. When the access gateway receives (in step 0) an ARP Request or Neighbor Solicitation message with IPv4 LLA from the UE, the access gateway replies (in step 0-A) with a PACP-Initialize message. The PACP-Initialize message includes source IPv4 address and a MAC address corresponding to the gateway interface to which subsequent PACP for configuring multiple interfaces should be sent. The UE uses the source address in the PACP-Initialize as the access gateway/destination address of requests that it sends.

[0041] Figure 9 illustrates another embodiment scheme 900 for IPv6 interface configuration. The scheme 900 is similar to the scheme 400. However, in the scheme 900, the UE further sets up a link local address after it has successfully authenticated with the network. At that point the access gateway (e.g., TWAG) sends to the UE a message from the router or gateway interface address to which subsequent PACP messages can be sent. When the access gateway receives (in step 0) a Neighbor Solicitation message with IPv6 LLA from the UE, the access gateway replies (in step 0-A) with a PACP-Initialize message. The PACP-Initialize message includes source IPv6 address and a MAC address corresponding to the gateway interface to which subsequent PACP for configuring multiple interfaces should be sent. The UE uses the source address in the PACP-Initialize as the access gateway/destination address of requests that it sends.

[0042] Figure 10 is a block diagram of an exemplary processing system 1000 that can be used to implement various embodiments. Specific devices may utilize all of the components shown, or only a subset of the components and levels of integration may vary from device to device. Furthermore, a device may contain multiple instances of a component, such as multiple processing units, processors, memories, transmitters, receivers, etc. The processing system 1000 may comprise a processing unit 1001 equipped with one or more input/output devices, such as a network interfaces, storage interfaces, and the like. The processing unit 1001 may include a central processing unit (CPU) 1010, a memory 1020, a mass storage device 1030, and an I/O interface 1060 connected to a bus. The bus may be one or more of any type of several bus architectures including a memory bus or memory controller, a peripheral bus or the like.

[0043] The CPU 1010 may comprise any type of electronic data processor. The memory 1020 may comprise any type of system memory such as static random access memory (SRAM), dynamic random access memory (DRAM), synchronous DRAM (SDRAM), read-only memory (ROM), a combination thereof, or the like. In an embodiment, the memory 1020 may include ROM for use at boot-up, and DRAM for program and data storage for use while executing

programs. In embodiments, the memory 1020 is non-transitory. The mass storage device 1030 may comprise any type of storage device configured to store data, programs, and other information and to make the data, programs, and other information accessible via the bus. The mass storage device 1030 may comprise, for example, one or more of a solid state drive, hard disk drive, a magnetic disk drive, an optical disk drive, or the like.

[0044] The processing unit 1001 also includes one or more network interfaces 1050, which may comprise wired links, such as an Ethernet cable or the like, and/or wireless links to access nodes or one or more networks 1080. The network interface 1050 allows the processing unit 1001 to communicate with remote units via the networks 1080. For example, the network interface 1050 may provide wireless communication via one or more transmitters/transmit antennas and one or more receivers/receive antennas. In an embodiment, the processing unit 1001 is coupled to a local-area network or a wide-area network for data processing and communications with remote devices, such as other processing units, the Internet, remote storage facilities, or the like.

[0045] While several embodiments have been provided in the present disclosure, it should be understood that the disclosed systems and methods might be embodied in many other specific forms without departing from the spirit or scope of the present disclosure. The present examples are to be considered as illustrative and not restrictive, and the intention is not to be limited to the details given herein. For example, the various elements or components may be combined or integrated in another system or certain features may be omitted, or not implemented.

[0046] In addition, techniques, systems, subsystems, and methods described and illustrated in the various embodiments as discrete or separate may be combined or integrated with other systems, modules, techniques, or methods without departing from the scope of the present disclosure. Other items shown or discussed as coupled or directly coupled or communicating with each other may be indirectly coupled or communicating through some interface, device, or intermediate component whether electrically, mechanically, or otherwise. Other examples of changes, substitutions, and alterations are ascertainable by one skilled in the art and could be made without departing from the spirit and scope disclosed herein.

WHAT IS CLAIMED IS:

1. A method, implemented by a network component using a dedicated protocol for supporting Packet Data Network (PDN) connections over a wireless access network, the method comprising:

receiving, from a user equipment (UE), a request to create a session associated with a PDN connection, the request indicating an Access Point Name (APN);

assigning a gateway Internet Protocol (IP) interface on a link between the UE and the network component;

sending, to the UE, an acknowledgement to create a session, the acknowledgement including the gateway IP interface;

sending, to a PDN gateway, a request for establishing the PDN connection; and

receiving, from the PDN gateway, a response including an assigned IP address for the session.

2. The method of claim 1 further comprising:

receiving, from the UE, a Dynamic Host Configuration Protocol (DHCP) request for associating the gateway IP interface with the PDN connection; and

sending, to the UE, a DHCP acknowledgement including the assigned IP address.

3. The method of claim 1, further comprising:

receiving, from the UE, an authentication message in accordance with an Extensible Authentication Protocol (EAP), the authentication message configuring a set of keys between the UE and the network component; and

exchanging with the UE a hash checksum according to a key of the set of keys.

4. The method of claim 3, further comprising:

receiving, from the UE, an Address Resolution Protocol (ARP) probe request indicating an IP version 4 (IPv4) address generated by the UE for the session; and

sending, to the UE, an initialize message including a source IPv4 address and a Media Access Control (MAC) address corresponding to the gateway IP interface.

5. The method of claim 3, further comprising:

receiving, from the UE, a Neighbor Solicitation message indicating an IP version 6 (IPv6) address generated by the UE for the session; and

sending, to the UE, an initialize message including a source IPv6 address and a Media Access Control (MAC) address corresponding to the gateway IP interface.

6. The method of claim 1, wherein the request to create a session associated with the PDN connection and the acknowledgement to create a session are transported as payloads in Internet Control Message Protocol (ICMP) Echo messages, and wherein the method further comprises:

sending back, to the UE, an echo message for the request to create a session to the UE;
and

receiving back, from the UE, an echo message for the acknowledgement to create a session.

7. The method of claim 1, wherein the request to create a session associated with a PDN connection and the acknowledgement to create a session are transported in IEEE 802.11 standard management frames.

8. The method of claim 1, wherein the request for establishing the PDN connection is a General Packet Radio Service (GPRS) Tunneling Protocol (GTP) Create Session request or a Proxy Mobile IP (PMIP) proxy binding update (PBU) message, and wherein the response is a GTP Create Session Response or a PMIP proxy binding acknowledgement (PBA).

9. The method of claim 1 further comprising:

receiving, from the UE, a second request to create a second session associated with a second PDN connection, the second request indicating a second Access Point Name (APN);

assigning a second gateway IP interface on the same link between the UE and the network component;

sending, to the UE, an acknowledgement to create the second session, the acknowledgement including the second gateway IP interface;

sending, to a second PDN gateway, a create session request for the second PDN connection; and

receiving, from the second PDN gateway, a create session response including a second assigned IP address for the second session.

10. The method of claim 1 further comprising:

detecting a trigger to detach the PDN connection for the APN;

sending, to the UE, a notify message to delete the session associated with the PDN connection, the notify message including the assigned IP address;

sending, to the PDN gateway, a request to delete the PDN connection, the request indicating the assigned IP address; and

receiving, from the PDN gateway, a response to delete the PDN connection.

11. The method of claim 10, wherein the notify message to delete the session associated with the PDN connection is transported as payload in an Internet Control Message Protocol (ICMP) Echo message, and wherein the method further comprises receiving back, from the UE, the notify message.

12. The method of claim 10, wherein the notify message to delete the session associated with the PDN connection is transported in an IEEE 802.11 standard management frame.

13. The method of claim 10, wherein the request to delete the PDN connection is a General Packet Radio Service (GPRS) Tunneling Protocol (GTP) Delete Session request or a Proxy Mobile IP (PMIP) proxy binding update (PBU) message, and wherein the response is a GTP Delete Session Response or a PMIP proxy binding acknowledgement (PBA).

14. The method of claim 1 further comprising:

receiving, from the UE, a notify message to delete the session associated with the PDN connection, the notify message including the assigned IP address;

sending, to the PDN gateway, a request to delete the PDN connection, the request indicating the assigned IP address; and

receiving, from the PDN gateway, a response to delete the PDN connection.

15. The method of claim 1, wherein the network component is an access gateway to a PDN, and wherein the link connects the UE to the access gateway via a wireless network access point (AP).

16. The method of claim 15 further comprising:

receiving, from a second UE previously connected to a second access gateway, a request to create a new session associated with a second PDN connection between the second access gateway and the PDN gateway, the request indicating a second APN;

assigning a second gateway IP interface on a link between the second UE and the network component;

sending, to the second UE, an acknowledgement to create a new session, the acknowledgement including the second gateway IP interface;

sending, to a PDN gateway, a request for establishing the second PDN connection;

receiving, from the PDN gateway, a response including a second assigned IP address for the new session;

receiving, from the second UE, a Dynamic Host Configuration Protocol (DHCP) request for associating the second gateway IP interface with the second PDN connection; and

sending, to the second UE, a DHCP acknowledgement including the second assigned IP address.

17. A method, implemented by a user equipment (UE) using a dedicated protocol for supporting Packet Data Network (PDN) connections over a wireless access network, the method comprising:

sending, to an access gateway, a request to create a session associated with a PDN connection, the request indicating an Access Point Name (APN);

receiving, from the access gateway, an acknowledgement to create a session including a gateway Internet Protocol (IP) interface assigned by the access gateway on a link between the UE and the access gateway;

sending, to the access gateway, a Dynamic Host Configuration Protocol (DHCP) request for associating the gateway IP interface with the PDN connection; and

receiving, from the access gateway, a DHCP acknowledgement including an assigned IP address forwarded by a PDN gateway to the access gateway.

18. The method of claim 17, further comprising:

sending, to the access gateway, an authentication message in accordance with an Extensible Authentication Protocol (EAP), the authentication message configuring a set of keys between the UE and the access gateway; and

exchanging with the access gateway a hash checksum according to a key of the set of keys.

19. The method of claim 18, further comprising:

sending, to the access gateway, an Address Resolution Protocol (ARP) probe request indicating an IP version 4 (IPv4) address generated by the UE for the session;

receiving, from the access gateway, an initialize message including a source IPv4 address and a Media Access Control (MAC) address corresponding to the gateway IP interface.

20. The method of claim 18, further comprising:

sending, to the access gateway, a Neighbor Solicitation message indicating an IP version 6 (IPv6) address generated by the UE for the session; and

receiving, from the access gateway, an initialize message including a source IPv6 address and a Media Access Control (MAC) address corresponding to the gateway IP interface.

21. The method of claim 17 further comprising:

sending, to the access gateway, a second request to create a second session associated with a second PDN connection, the second request indicating a second Access Point Name (APN);

receiving, from the access gateway, an acknowledgement to create the second session, the acknowledgement including a second gateway IP interface assigned by the access gateway on the link between the UE and the access gateway;

sending, to the access gateway, a Dynamic Host Configuration Protocol (DHCP) request for associating the second gateway IP interface with the second PDN connection; and

receiving, from the access gateway, a DHCP acknowledgement including a second assigned IP address forwarded by the PDN gateway or a second PDN gateway to the access gateway.

22. The method of claim 17 further comprising:

detecting a trigger to detach the PDN connection for the APN;

sending, to the access gateway, a notify message to delete the session associated with the PDN connection, the notify message including the assigned IP address; and

releasing the session on the link with the access gateway.

23. The method of claim 17 further comprising:

receiving, from the access gateway, a notify message to delete the session associated with the PDN connection, the notify message including the assigned IP address; and

releasing the session on the link with the access gateway.

24. The method of claim 17 further comprising:

upon moving to a second access gateway, sending from the UE to the second access gateway a request to create a new session associated with the same PDN connection, the request indicating the APN;

receiving, from the second access gateway, an acknowledgement to create a new session including a second gateway IP interface assigned by the second access gateway on a second link between the UE and the second access gateway;

sending, to the second access gateway, a Dynamic Host Configuration Protocol (DHCP) request for associating the second gateway IP interface with the PDN connection; and

receiving, from the second access gateway, a DHCP acknowledgement including the assigned IP address forwarded by the PDN gateway to the second access gateway.

25. The method of claim 24 further comprising:

sending, to the access gateway, a DHCP release or a notify message to delete the session associated with the PDN connection; and

releasing the session on the link with the access gateway.

26. An access gateway supporting Packet Data Network (PDN) connections over a wireless access network, the access gateway comprising:

at least one processor; and

a non-transitory computer readable storage medium storing programming for execution by the at least one processor, the programming including instructions to:

receive, from a user equipment (UE), a request to create a session associated with a PDN connection, the request indicating an Access Point Name (APN);

assign a gateway Internet Protocol (IP) interface on a link between the UE and the access gateway;

send, to the UE, an acknowledgement to create a session, the acknowledgement including the gateway IP interface;

send, to a PDN gateway, a request for establishing the PDN connection; and

receive, from the PDN gateway, a response including an assigned IP address for the session.

27. The access gateway of claim 26, wherein the programming includes further instructions to:

receive, from the UE, a Dynamic Host Configuration Protocol (DHCP) request for associating the gateway IP interface with the PDN connection; and
send, to the UE, a DHCP acknowledgement including the assigned IP address.

28. The access gateway of claim 26, wherein the programming includes further instructions to:

receive, from the UE, an authentication message in accordance with an Extensible Authentication Protocol (EAP), the authentication message configuring a set of keys between the UE and the access gateway; and

exchange with the UE a hash checksum according to a key of the set of keys.

29. The access gateway of claim 26, wherein the programming includes further instructions to:

send to or receive from the UE a notify message to delete the session associated with the PDN connection, the notify message including the assigned IP address;

send, to the PDN gateway, a request to delete the PDN connection, the request indicating the assigned IP address; and

receive, from the PDN gateway, a response to delete the PDN connection.

30. The access gateway of claim 26, wherein the link connects the access gateway to the UE via a wireless local access network (WLAN) access point (AP).

31. A user equipment (UE) supporting Packet Data Network (PDN) connections over a wireless access network, the UE comprising:

at least one processor; and

a non-transitory computer readable storage medium storing programming for execution by the at least one processor, the programming including instructions to:

send, to an access gateway, a request to create a session associated with a PDN connection, the request indicating an Access Point Name (APN);

receive, from the access gateway, an acknowledgement to create a session including a gateway Internet Protocol (IP) interface assigned by the access gateway on a link between the UE and the access gateway;

send, to the access gateway, a Dynamic Host Configuration Protocol (DHCP) request for associating the gateway IP interface with the PDN connection; and

receive, from the access gateway, a DHCP acknowledgement including an assigned IP address forwarded by a PDN gateway to the access gateway.

32. The UE of claim 31, wherein the programming includes further instructions to:
send, to the access gateway, an authentication message in accordance with an Extensible Authentication Protocol (EAP), the authentication message configuring a set of keys between the UE and the access gateway; and
exchange with the access gateway a hash checksum according to a key of the set of keys.
33. The UE of claim 31, wherein the programming includes further instructions to:
send to or receiving from the access gateway a notify message to delete the session associated with the PDN connection, the notify message including the assigned IP address; and
release the session on the link with the access gateway.

100

FIG. 1

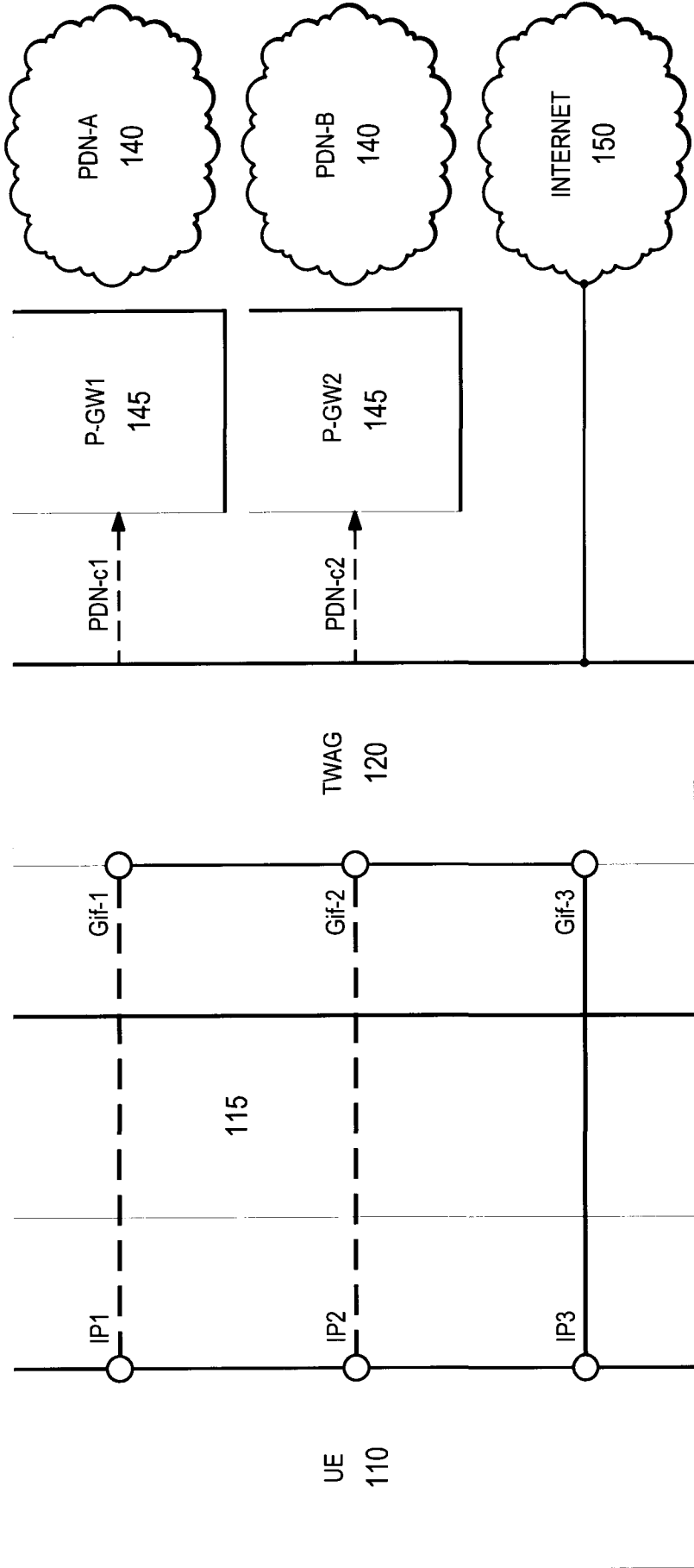

200

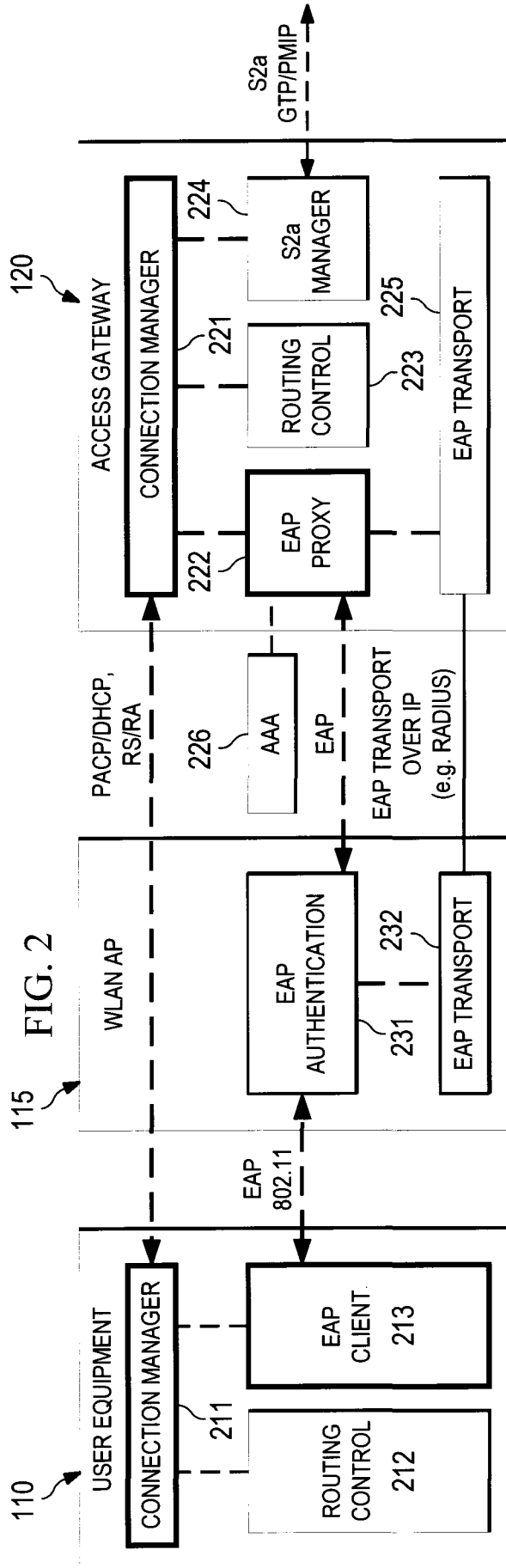

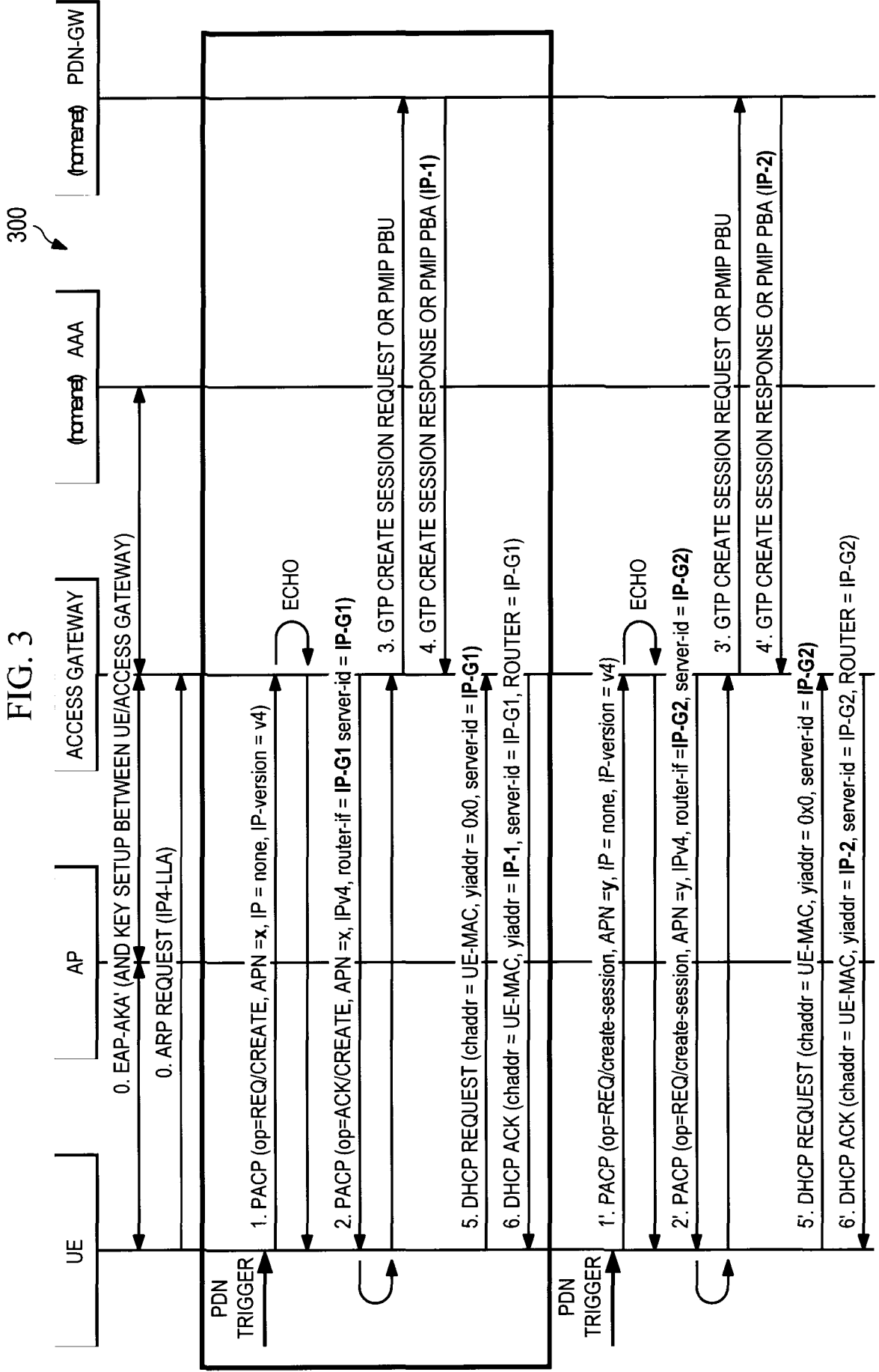

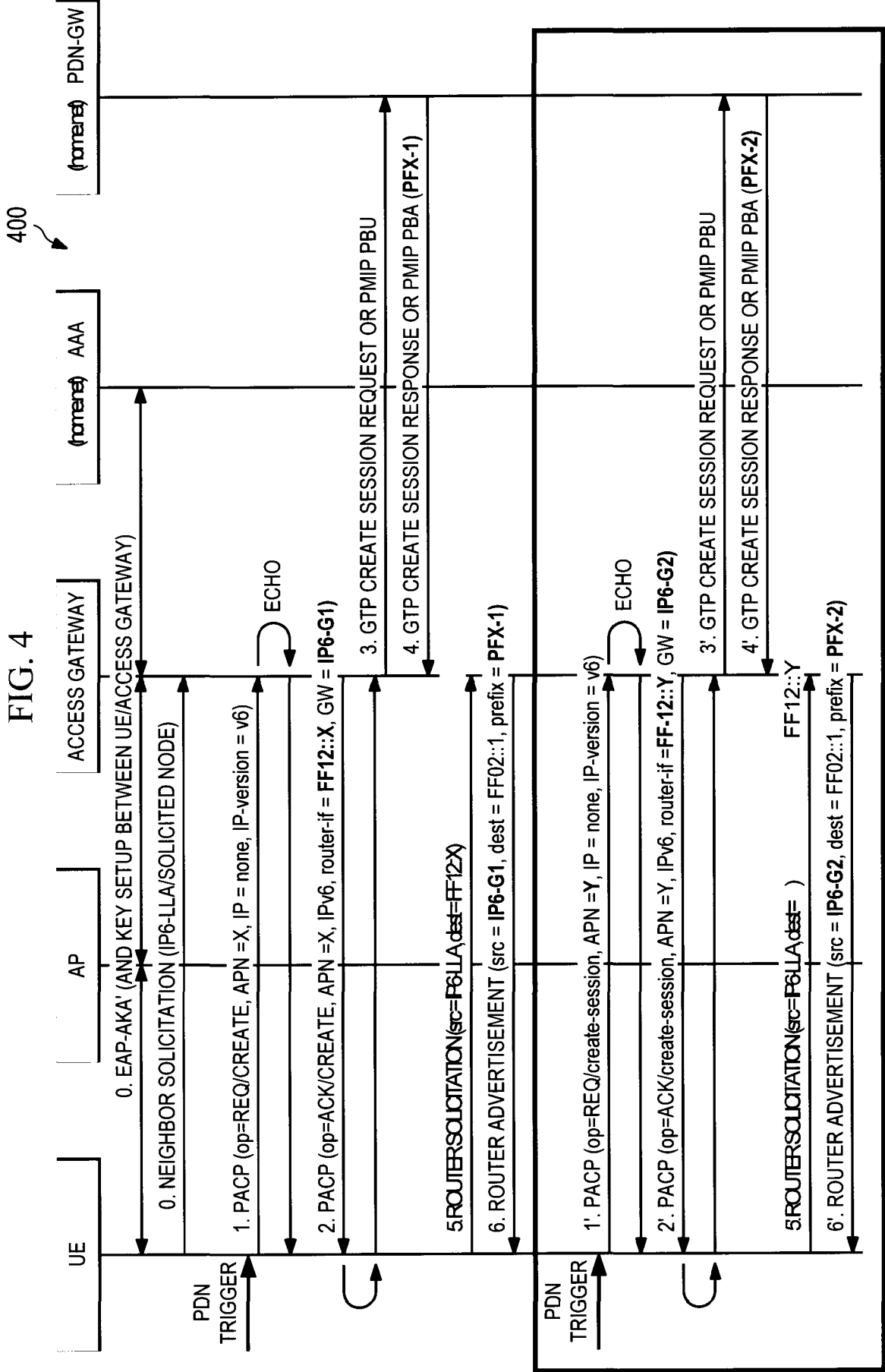

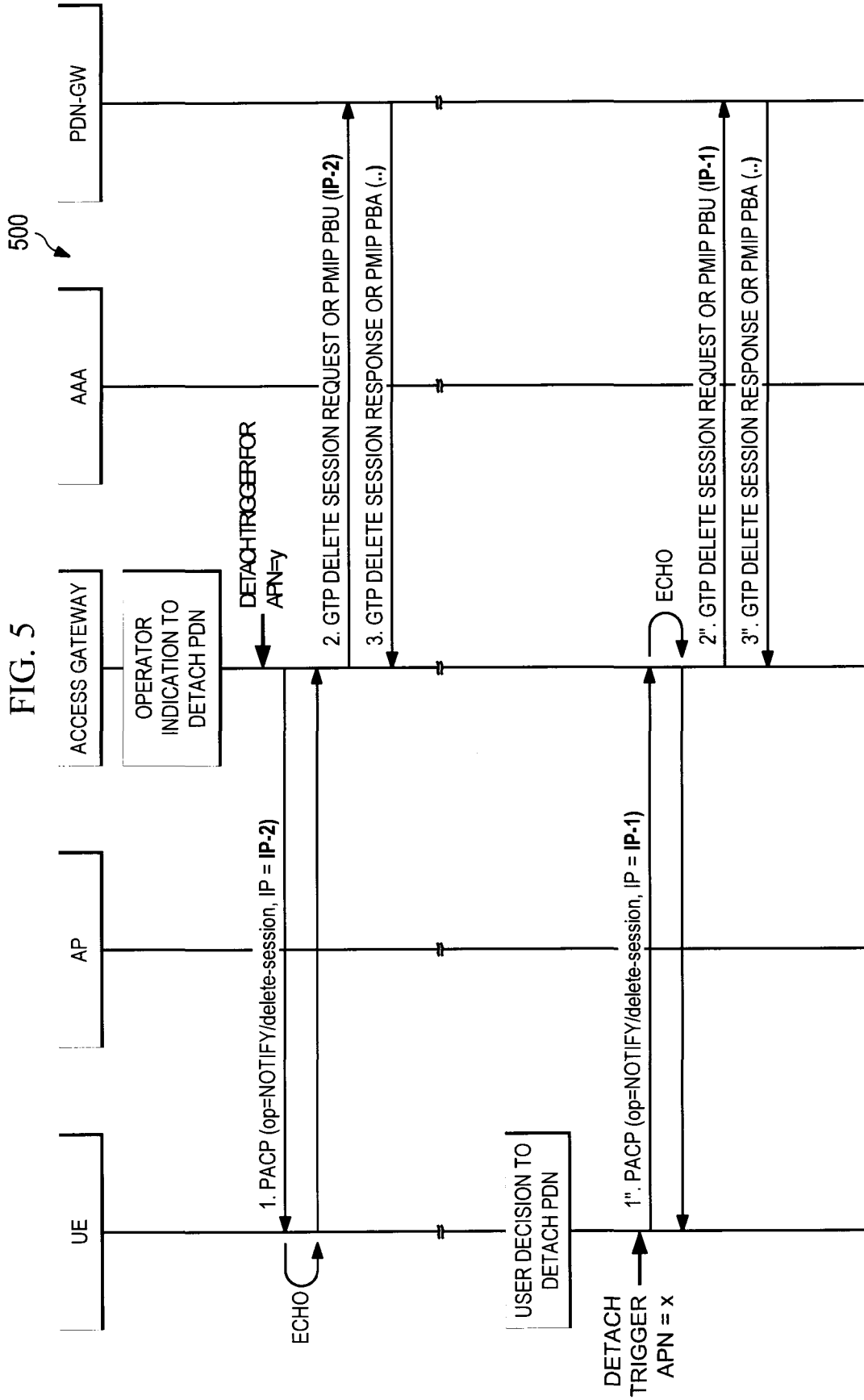

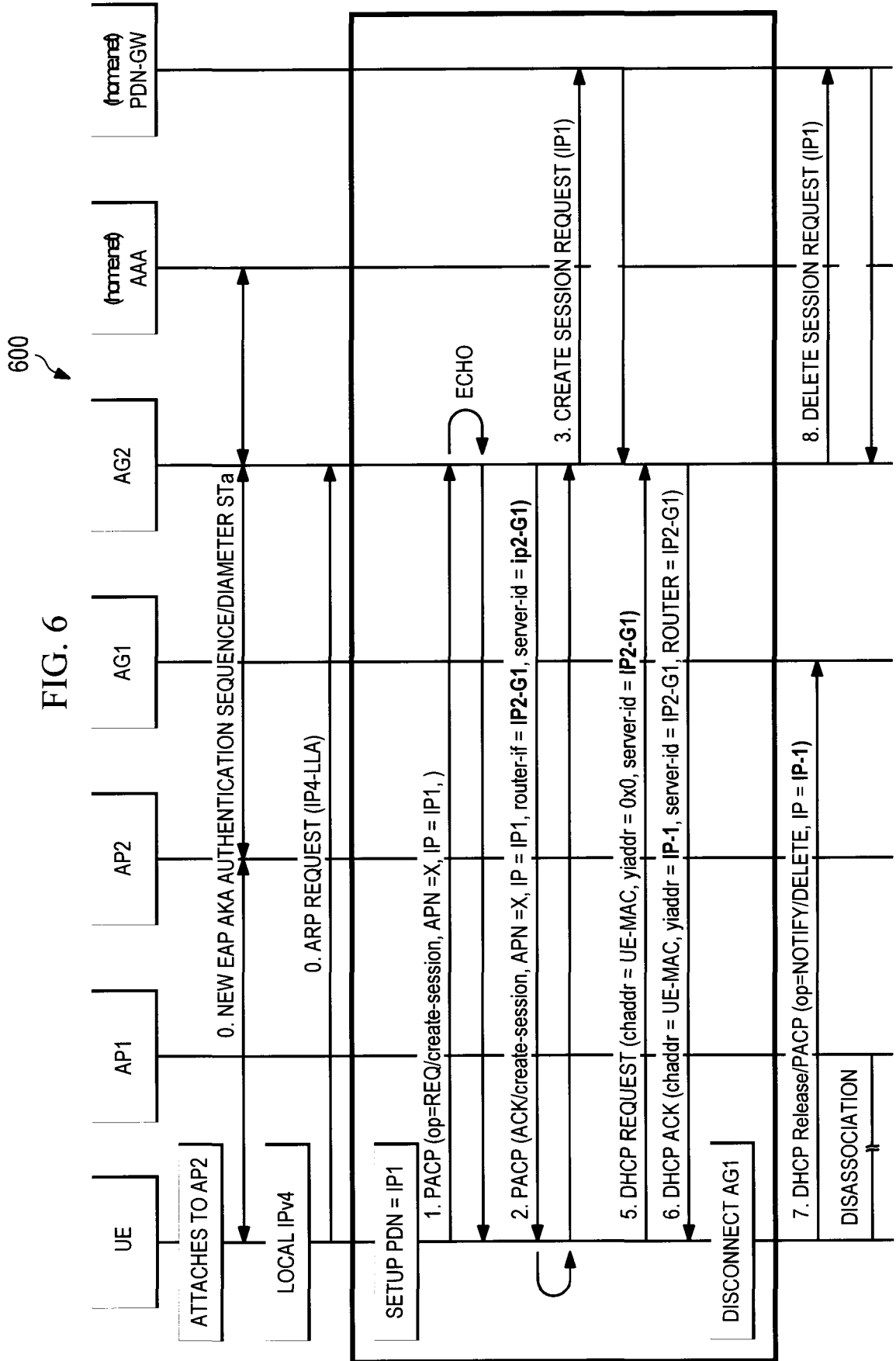

700

FIG. 7

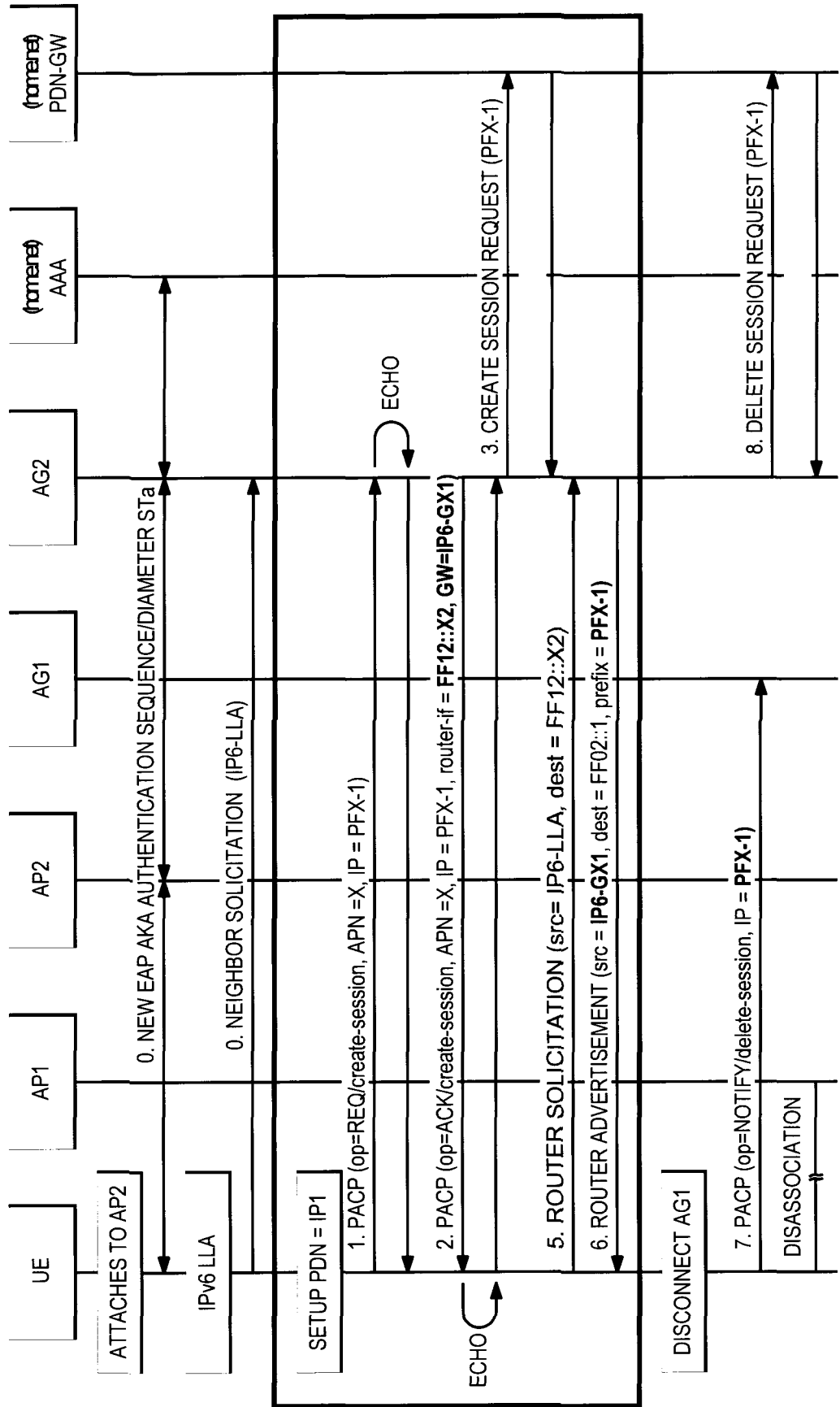

800

FIG. 8

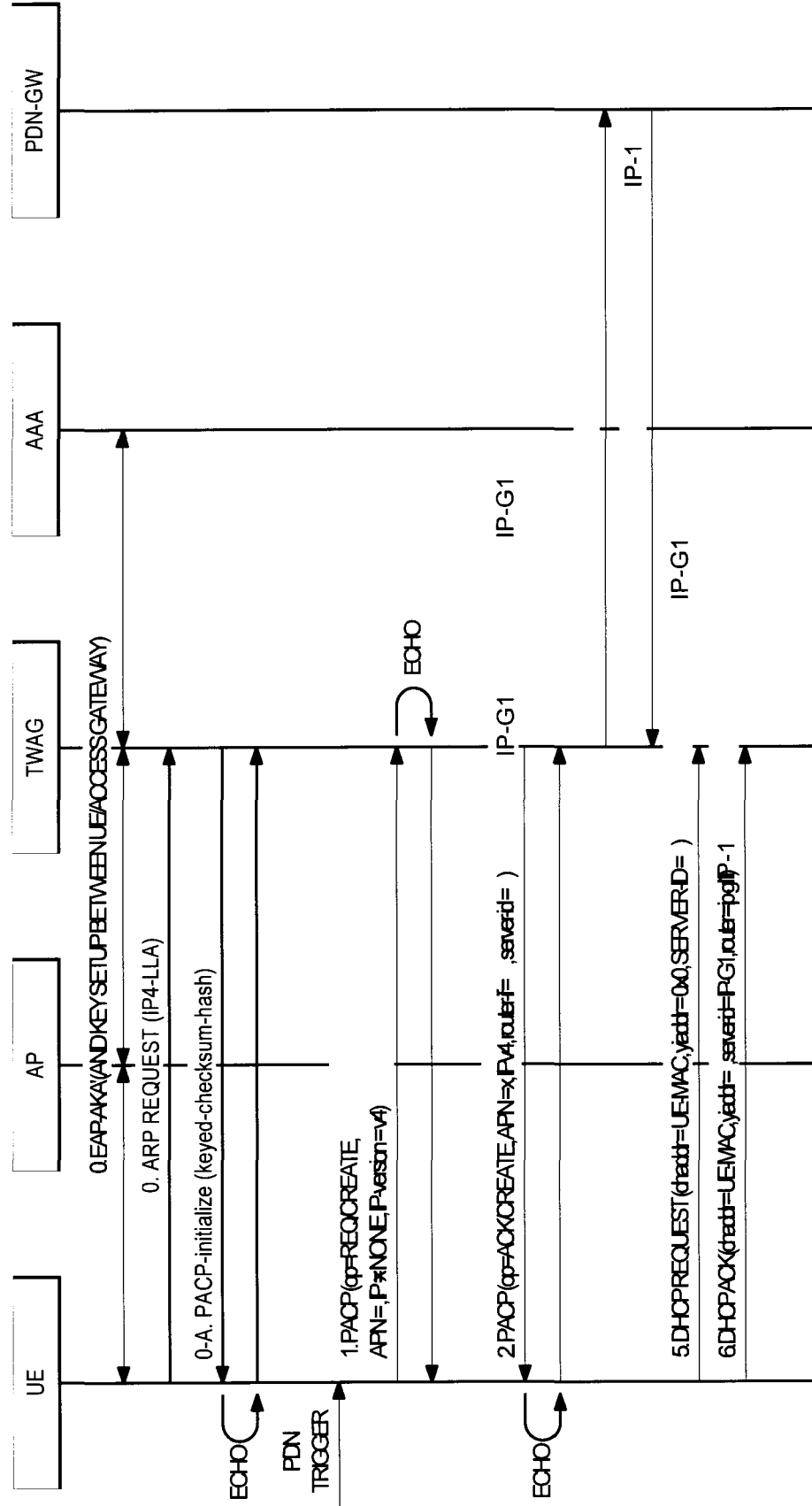

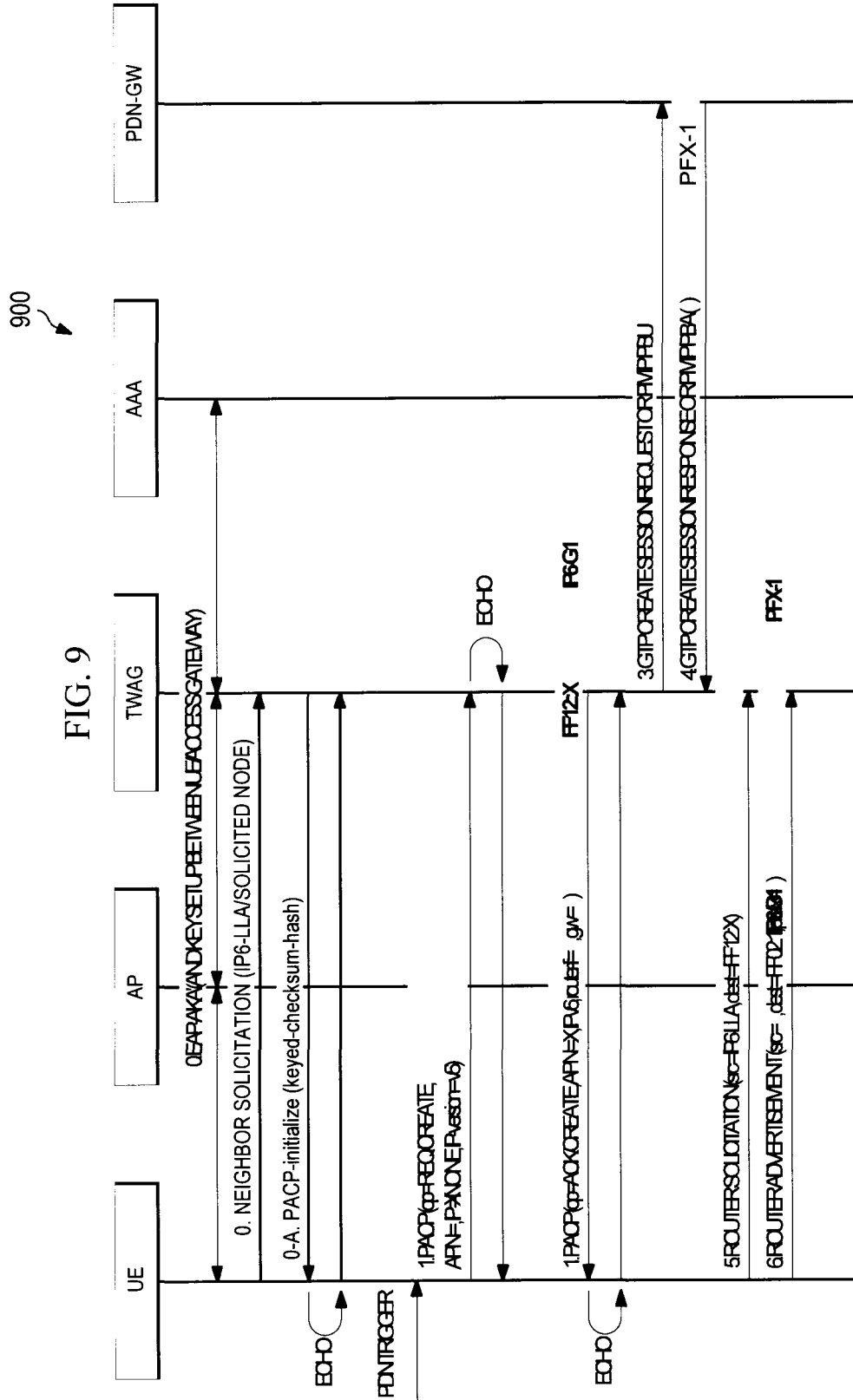

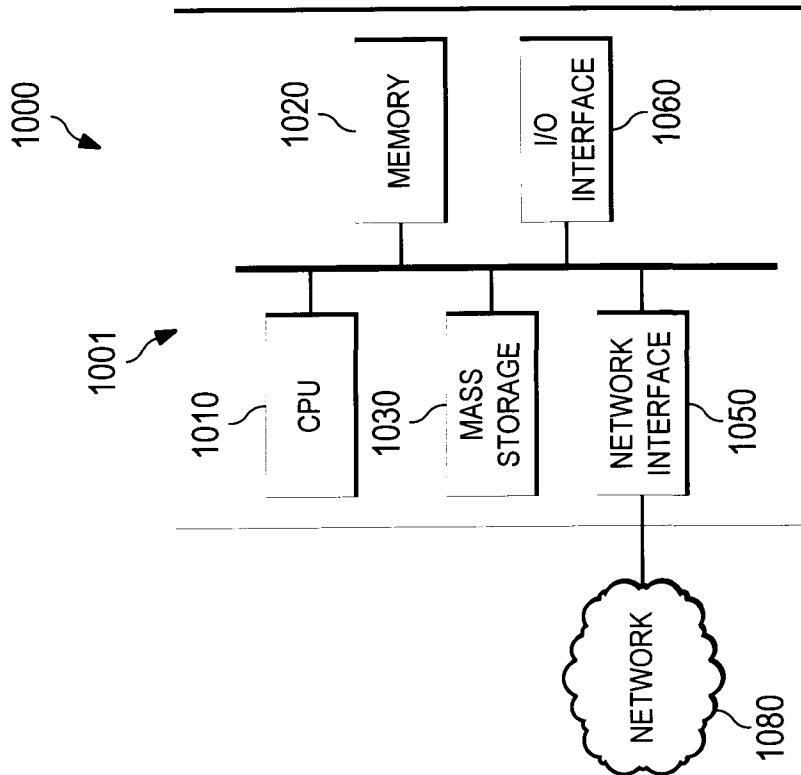

FIG. 10

INTERNATIONAL SEARCH REPORT

International application No.

PCT/CN2013/083557

A. CLASSIFICATION OF SUBJECT MATTER

See the extra sheet

According to International Patent Classification (IPC) or to both national classification and IPC

B. FIELDS SEARCHED

Minimum documentation searched (classification system followed by classification symbols)

IPC: H04W 48/-; H04L12/-; H04L 29/-

Documentation searched other than minimum documentation to the extent that such documents are included in the fields searched

Electronic data base consulted during the international search (name of data base and, where practicable, search terms used)

WPI, EPODOC, IEEE, CNPAT, CNKI, GOOGLE: UE, PDN, APN, IP, multiple, DHCP, gateway, EAP

C. DOCUMENTS CONSIDERED TO BE RELEVANT

Category*	Citation of document, with indication, where appropriate, of the relevant passages	Relevant to claim No.
X	CN 101801102 A (HUAWEI TECHNOLOGIES CO., LTD.) 11 August 2010 (11.08.2010) description, paragraphs [0037]-[0072] and figure 2	1, 7, 9, 15, 26, 30
A	CN 101388830 A (HUAWEI TECHNOLOGIES CO., LTD.) 18 March 2009 (18.03.2009) the whole document	1-33
A	CN 101547142 A (HUAWEI TECHNOLOGIES CO., LTD.) 30 September 2009 (30.09.2009) the whole document	1-33
A	WO 2009158703 A1 (STARENT NETWORKS, CORP.) 30 December 2009 (30.12.2009) the whole document	1-33
A	3rd Generation Partnership Project; Technical Specification Group Services and System Aspects; Architecture enhancements for non-3GPP accesses (Release 11), 3GPP TS 23.402 V11.3.0, June 2012 (06.2012), chapter 16	1-33

 Further documents are listed in the continuation of Box C. See patent family annex.

* Special categories of cited documents:	“T” later document published after the international filing date or priority date and not in conflict with the application but cited to understand the principle or theory underlying the invention
“A” document defining the general state of the art which is not considered to be of particular relevance	“X” document of particular relevance; the claimed invention cannot be considered novel or cannot be considered to involve an inventive step when the document is taken alone
“E” earlier application or patent but published on or after the international filing date	“Y” document of particular relevance; the claimed invention cannot be considered to involve an inventive step when the document is combined with one or more other such documents, such combination being obvious to a person skilled in the art
“L” document which may throw doubts on priority claim (S) or which is cited to establish the publication date of another citation or other special reason (as specified)	“&” document member of the same patent family
“O” document referring to an oral disclosure, use, exhibition or other means	
“P” document published prior to the international filing date but later than the priority date claimed	

Date of the actual completion of the international search 13 November 2013 (13.11.2013)	Date of mailing of the international search report 19 Dec. 2013 (19.12.2013)
--	--

Name and mailing address of the ISA/CN
The State Intellectual Property Office, the P.R.China
6 Xitucheng Rd., Jimen Bridge, Haidian District, Beijing, China
100088
Facsimile No. 86-10-62019451

Authorized officer

MU, Ying

Telephone No. (86-10)62413989

INTERNATIONAL SEARCH REPORT
Information on patent family members

International application No.
PCT/CN2013/083557

Patent Documents referred in the Report	Publication Date	Patent Family	Publication Date
CN 101801102 A	11.08.2010	None	
CN 101388830 A	18.03.2009	WO 2009036694 A1	26.03.2009
CN 101547142 A	30.09.2009	CN 102123493 A	13.07.2011
		WO 2009117891 A1	01.10.2009
WO 2009158703 A1	30.12.2009	US 2010027448 A1	04.02.2010

INTERNATIONAL SEARCH REPORT

International application No.

PCT/CN2013/083557

Continuation of : CLASSIFICATION OF SUBJECT MATTER

H04W 74/00 (2009.01) i

H04L 12/70 (2013.01) n