

(19)
(12)

(KR)
(Y1)

(51) 。 Int. Cl.⁷
A63H 5/00

(45)
(11)
(24)

2003 07 22
20-0320748
2003 07 08

(21) 20-2003-0013296
(22) 2003 04 29

(73) 472 101 1406

(72) 472 101 1406

(74)

:

가 :

(54)

가

1

2

3

4

5

6a 6f

**

**

10 ; 11 ;

20 ; 21 ;

30 ; 40 ;

41 ; 42 ;

43 ;

, 가

1

(2)가

(球)

(1)

(1)

가

, 2
) , (3)가

(2)

(1)

(2)가

X

(1)

가
(3)

(3)

가

(2)가

가

가

가

(1)

가

가

가

가 0) (10) (30) (40)가 가 (20) , 5f (10) (11) (40) (20) (42) (1)

가

(57)

1.

2.

1

가

3.

1

가

4.

1

1

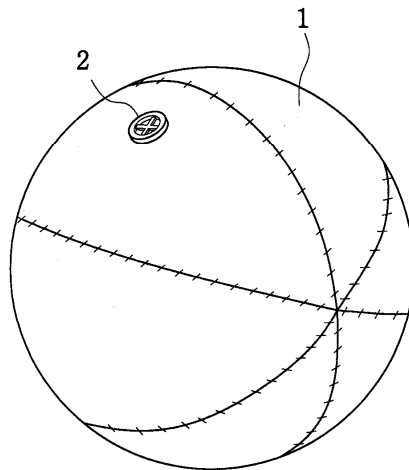

2

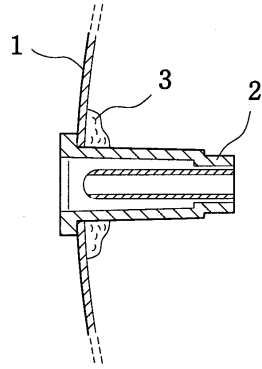

3

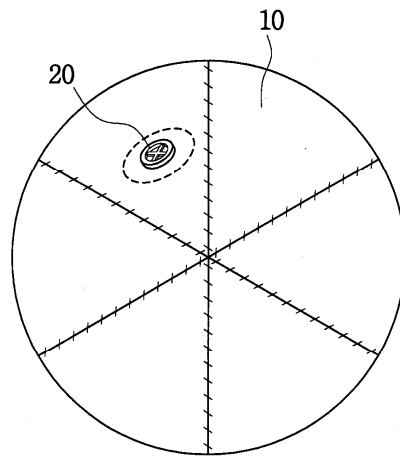

4

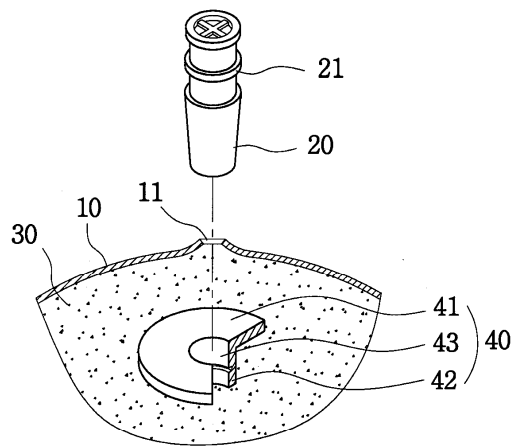

5a

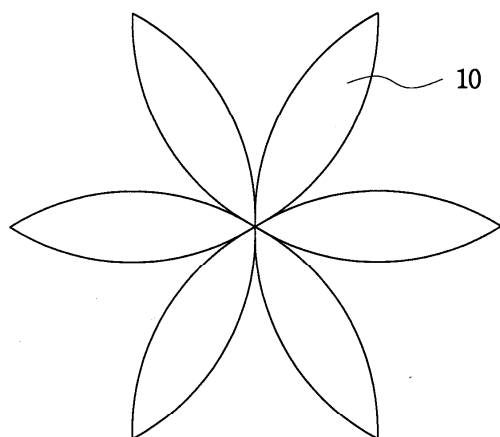

5b

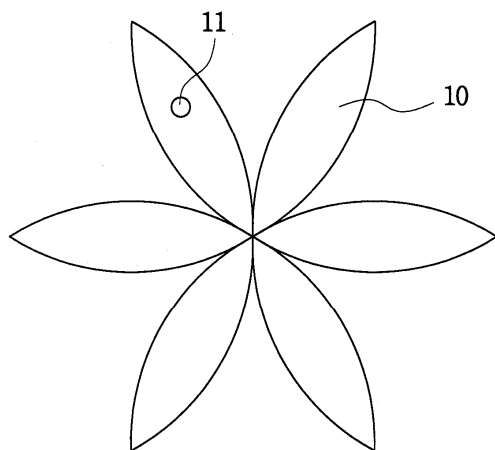

5c

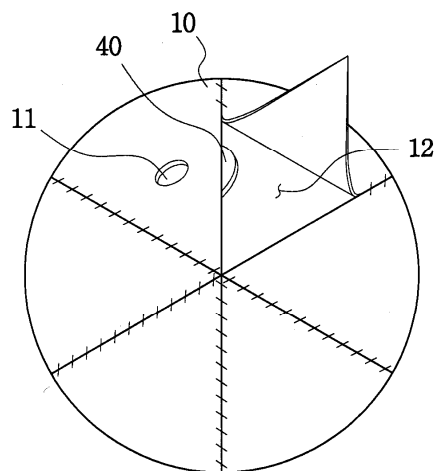

5d

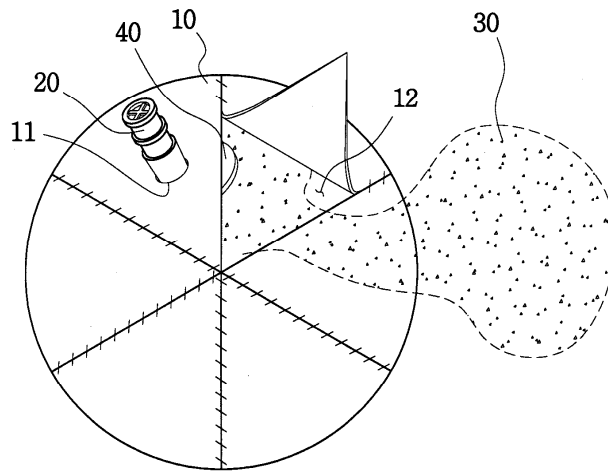

5e

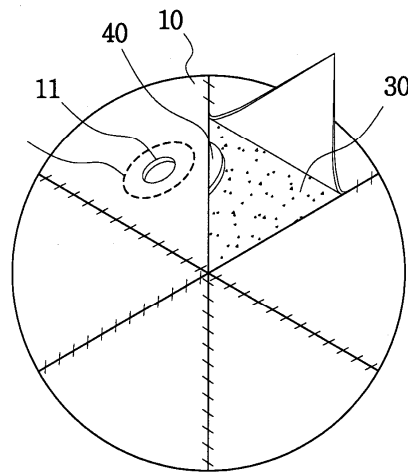

5f

