

Dec. 13, 1932.

R. L. HARDEN  
COMBINATION PACKAGE  
Filed Jan. 20, 1930

1,890,988

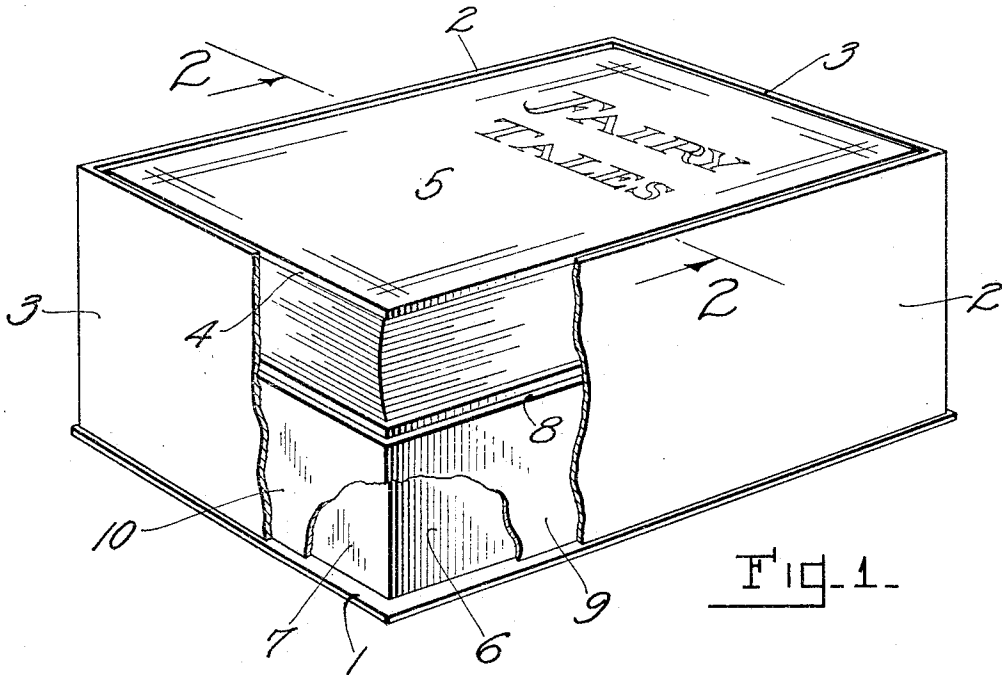

Fig. 1.

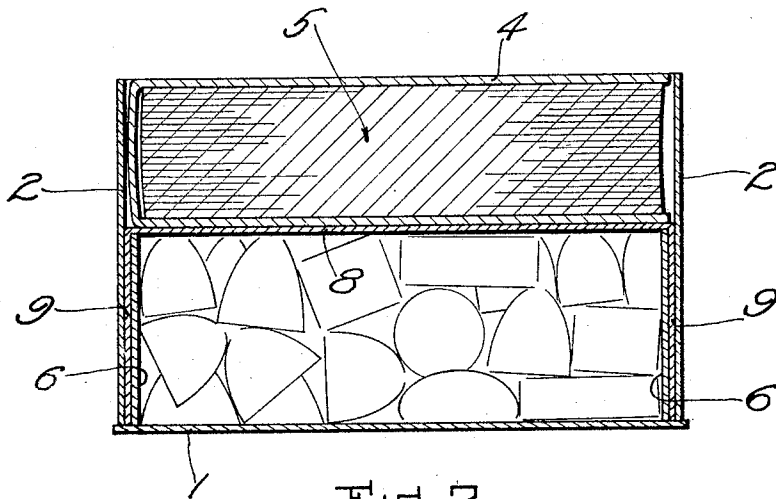

Fig. 2.

*Ralph L. Harden*  
INVENTOR

by *John C. Walton*  
ASSOC. ATTORNEY

# UNITED STATES PATENT OFFICE

RALPH L. HARDEN, OF NORTH ATTLEBORO, MASSACHUSETTS, ASSIGNOR TO THE MASON BOX COMPANY, OF ATTLEBORO FALLS, MASSACHUSETTS, A CORPORATION OF MASSACHUSETTS

## COMBINATION PACKAGE

Application filed January 20, 1930. Serial No. 421,952.

The invention relates to the combining of different and preferably unrelated articles or products in one package for merchandising.

The general object of the invention is to provide a combination package of the above character in a compact form best adapted for merchandising; to provide a package in which the boxing structure is relatively simple and inexpensive, and especially to provide a package attractive in appearance fitted with a display top.

I have found that the objects of the invention may be attained if a book be employed as one of the packaged articles inasmuch as a book may be so combined with the other article in the one package, as will later be explained, as to obtain an ideal form for merchandising; one in which the boxing of the book adds but little to the cost of the package and in fact effects economy in the relative cost of the package having as it does a display top, inasmuch as the cover of the book itself forms this top.

The invention can best be seen and understood by reference to the drawing, in which—

Figure 1 is a longitudinal vertical section of the package, and

Fig. 2 is a vertical cross section of the package.

Referring to the drawing:—

The combination package as shown in Fig. 1, rectangular in form, comprises a bottom 1, side and end walls 2, 2; 3, 3, respectively, and a top 4. The bottom, side and end walls are of cardboard or similar material. The top 4 is the front cover of a contained book 5. This book is so arranged within the enveloping side and end walls 2, 2; 3, 3, of the package that the front cover of the book or the paper jacket thereon forms the top of the package. Inasmuch as the outer cover of the book or jacket thereon as aforesaid is of attractive appearance and usually embellished, it has, when combined with the side and end walls of the package as aforesaid, the effect of imparting a display top to the package in almost perfect simulation of a display cover.

Provision is made for supporting the book and for boxing another article or commodity such as candy inside the package in the fol-

lowing manner: The bottom 1 of the package forms the bottom of a contained or inside box body having side and end walls 6, 6; 7, 7, respectively, these walls cooperating with the bottom to form an ordinary paper or cardboard box. Fitting upon this inside box body is a slip cover comprising a top 8 with depending side and end walls 9, 9; 10, 10, respectively. This cover slips over the body of the box in the usual manner of a slip cover and the top 8 of the cover when fitting on the box body forms the support on which the book rests.

Provision having thus been made for supporting the book and boxing the associated article, the package is completed by the application to the inside box of a rectangular collar made up of the walls 2, 2; 3, 3, respectively which form, as before described, the side and end walls of the completed package. This collar when applied to the inside box rests along its bottom edge against the bottom 1 of the box, which bottom forms also the bottom of the completed package. The upward extension of the collar when bearing along its bottom edge against the bottom 1 is such that it will rise above the top 8 of the box cover, on which the book is resting, a distance substantially equal to the thickness of the book so that the front cover of the back or jacket thereon will lie about flush with the top edge of the collar and thereby cooperate with the collar, forming as it does the side and end walls of the package, to form the finished top of the package. In order that this effect may be properly attained, the length and width of the inside box should be substantially equal to the length and width of the book supported by it, and the height of the enveloping collar should be substantially equal to the thickness of the combined inside box and book. If desired the collar may be fastened, as by gluing, to the side and end walls of the cover of the inside box.

The package thus formed is a very simple and economic one consisting, apart from the contained articles, only of the inside box housing one of the articles, and the enveloping collar. Inasmuch as the inside box is concealed in the complete package, this box

may be a plain box. What might otherwise materially add to the expense of a package of this kind having a display top is entirely obviated in the construction above outlined, for the reason that the cover of the  
5 contained book, or jacket thereon, forms the display top, and the housing of the book and formation of the complete package is effected only by the addition of the collar.

10 By the term "cover" as used herein and in the appended claims is meant a cover with or without a paper jacket.

Having thus fully described my invention, I claim and desire to secure by Letters Pat-  
15 ent of the United States:—

1. In a combination package for achieving a certain display effect, a rectangular box provided with a bottom, side and end walls, a rectangular slip cover for and resting on  
20 the box and comprising side and end walls having a medial horizontal partition forming two compartments, the walls of one of the compartments extending adjacent or close to the bottom edge of the box and so constructed as to maintain the box in its proper  
25 associated position, and a rectangular article filling the top compartment of the slip cover and constituting a display top.

2. A combination package for obtaining a display effect comprising a rectangular box  
30 body having a bottom with upturned sides and ends, and forming within a compartment, a rectangular slip cover for said body having a medial horizontal partition with  
35 side and end walls extending downwardly to substantially conceal said box and having its parts arranged to rest on the box and limit the relative movement toward each other, and further having said walls extending upwardly  
40 to form in cooperation with said partition a top compartment, and a book filling said top compartment, said book having a display cover constituting the display top of said combination package.

45 RALPH L. HARDEN.

50

55

60

65