

[54] **DISPOSABLE MEDICAL ELECTRODE**

3,701,346 10/1972 Patrick et al. .... 128/2.06 E

[75] Inventor: **David L. Krasnow**, Canton, Mass.

*Primary Examiner*—Richard A. Gaudet

[73] Assignee: **Jet Medical Products Inc.**, Braintree, Mass.

*Assistant Examiner*—Lee S. Cohen

[22] Filed: **Aug. 14, 1972**

*Attorney, Agent, or Firm*—Dike, Bronstein, Roberts & Cushman

[21] Appl. No.: **280,350**

[57] **ABSTRACT**

[52] **U.S. Cl.**..... 128/2.1 E, 128/417, 128/DIG. 4

[51] **Int. Cl.**..... A61b 5/04

[58] **Field of Search** ..... 128/2.06 E, 2.1 E, DIG. 4, 128/418, 417, 416, 404, 405, 410, 411; 204/155 B

A disposable medical electrode comprising a support member made of a closed cell plastic material having an adhesive surface. A centrally located contact element is embedded therein so as to leave an exposed portion thereof at the adhesive side of the support member. A smaller pad member made up of an open cell plastic material is adhered to the adhesive surface of the support member at a position opposite to and in contact with the exposed portion of the contact element. In use, the pad member has a conductive gel dispersed throughout so that when the electrode is placed against the skin of a patient a good conductive path is present from the skin through the gelled pad to the contact element.

[56]

**References Cited**

**UNITED STATES PATENTS**

2,055,540	9/1936	Karnofsky.....	128/417 X
3,340,868	9/1967	Darling.....	128/2.06 E
3,534,727	10/1970	Roman.....	128/2.06 E
3,545,432	12/1970	Berman.....	128/2.06 E
3,581,736	6/1971	Zenkieh.....	128/3.06 E
3,587,565	6/1971	Tatoian.....	128/2.06 E
3,696,807	10/1972	Szpur.....	128/DIG. 4 X

**11 Claims, 6 Drawing Figures**

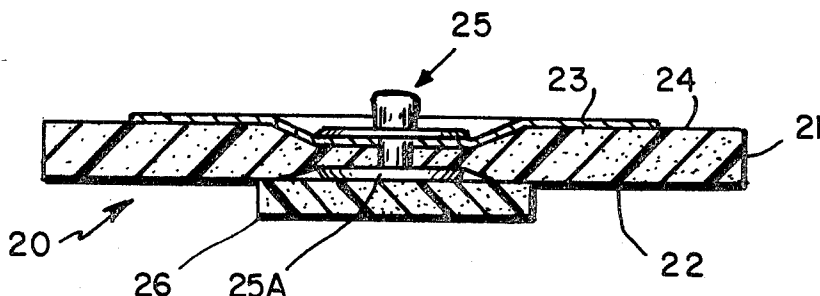

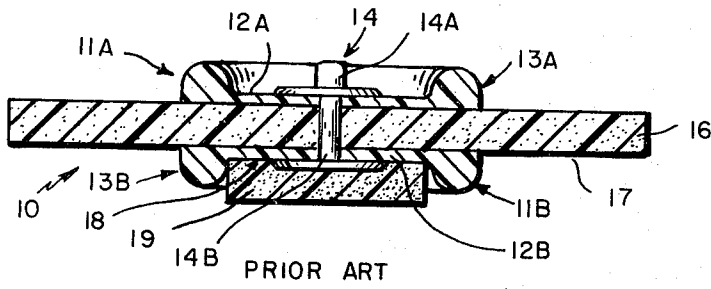
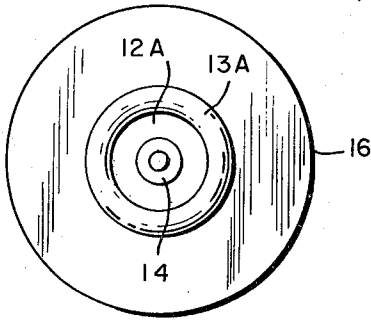

FIG. 1



PRIOR ART  
FIG. 1A

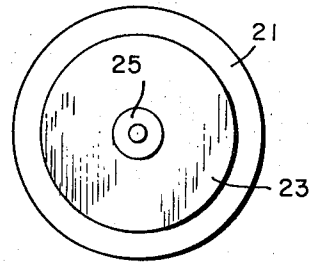

FIG. 2A

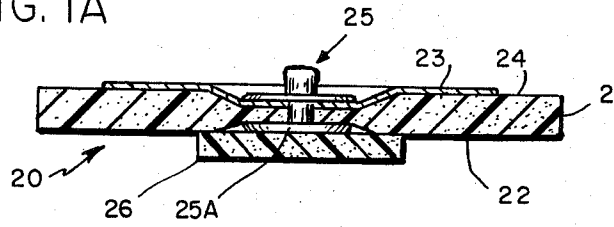

FIG. 2

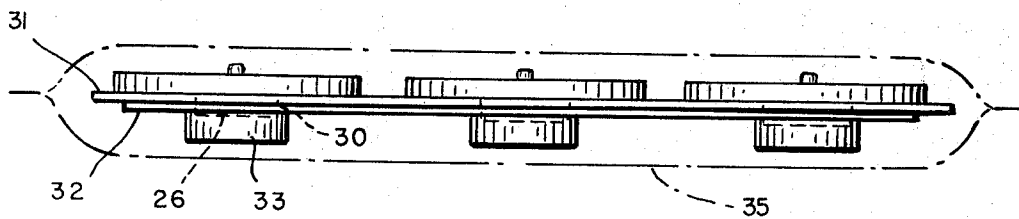

FIG. 4

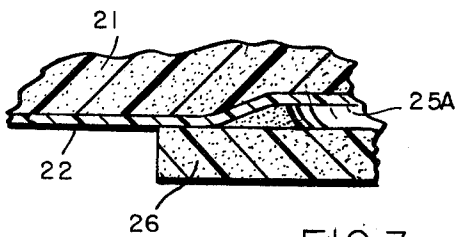

FIG. 3

## DISPOSABLE MEDICAL ELECTRODE

## DISCLOSURE OF THE INVENTION

## 1. Introduction

This application relates generally to medical electrodes and, more particularly, to disposable monitoring electrodes utilizing conductive gels for providing conductive contact between the human body and a metallic contact element.

## 2. Background of the Invention

Disposable electrodes have found widespread use in the medical field where it is desired to make electrical contact at some point on a patient's body so that electrical signals therefrom can be applied to appropriate monitoring equipment. The primary characteristic of such electrodes is to obtain as good a contact as possible between the skin area which is being monitored and the metallic contact element of the electrode so that a maximum electrical signal can be obtained for use in the monitoring equipment. An important further characteristic of such electrodes is that they be so designed as to minimize the discomfort which a patient will suffer, especially when such electrode may be required to be used over a prolonged period of time, sometimes for several days.

It is particularly desirable that such electrodes provide maximum signal strength with minimal discomfort for more sensitive patients, such as adults with sensitive skin and children or infants whose skin is apt to be more tender than that of adults. The comfort factor may be particularly important when used with extremely small infants, less than 30 days old, in the growing field of neo-natology.

## DESCRIPTION OF THE PRIOR ART

A conventionally structured electrode presently available for use in the medical field is a type which utilizes a conductive gel between the skin area which is being contacted and the metallic contact element of the electrode to which the monitoring circuit is connected. In such presently used electrodes the metal contact element is normally affixed to a rigid plastic base member of the electrode, the contact element being in the form of a snap fastener assembly having a first side to which a monitoring circuit is snap connected and a second oppositely disposed side which is in contact with a pad member made of an open cell plastic material permeated with a conductive gel. The pad is in turn in pressure contact with the skin, the conductive gel thereby assuring that a good conductive path is present from the skin to the metal contact element for the signal which is being monitored.

In such prior art electrodes the gel pad is freely nested in a recessed region of the electrode which is formed by a solid ridged portion of the rigid plastic body member, the outer surface of the ridge coming into pressure contact with the skin adjacent the outer perimeter of the gel pad when the electrode is in use. The ridged body member containing the snap fastener contact element is attached to a circularly shaped open cell plastic foam material one side of which has an adhesive thereon so that the electrode can adhere to the skin. The protruding ridge is thereby between the open cell adhesive foam material and the open cell gel pad foam material to form a barrier therebetween so as to prevent the conductive gel in the gel pad from being

absorbed by and dispersed throughout the open cell adhesive foam portion of the overall electrode. Unfortunately, however, the presence of the ridge tends to cause excessive discomfort to the patient on whom the electrode is being used since the ridge which digs into the skin of the patient can become extremely irritating.

Moreover, since the gel pad itself is held within the recessed portion of the electrode only by means of the surface tension created between the gel material and the surface of the solid ridged member of the electrode, the gel pad can often fall out of its recessed nest during handling and must be replaced by hand or other means, all of which tends to cause the gel pad to become less sanitary in use than is desired.

## SUMMARY OF THE INVENTION

In the monitoring electrode of the invention the need for a ridged barrier between a conductor gel pad and an adhesive portion of the electrode is eliminated so that a relatively smooth surface is presented to the skin of the patient and any irritation and discomfort caused by the presence of a ridge is completely avoided. In the structure of the invention, the adhesive base member of the electrode to which a snap fastener contact element is attached is made of a plastic foam material having a closed cell configuration. A gel pad made of a plastic foam material having an open cell configuration is then adhered to the underside of the closed cell foam material opposite the underside of the snap fastener contact element.

In one preferred embodiment of the invention a thin vinyl plastic strip is adhered to the upper side of the closed cell body member to provide some rigidity thereto. Because of the closed cell nature of the adhesive base member of the electrode, substantially none of the conductive gel which is dispersed throughout the open cell gel pad can be absorbed by or dispersed within the closed cell material and the gel is adequately retained within the open cell gel pad during manufacture, shipment and use. Moreover, because no solid plastic ridged member is used, the surface of the electrode which comes into contact with the skin of the patient is essentially soft and relatively smooth with no protruding ridges so that it can be readily placed on the patient's skin for good adherence without discomfort even with prolonged use.

In the preferred embodiment of the invention the lower surface of the contact element which is in contact with the gel pad may be coated with silver so that, in reacting with the gel substance a silver/silver chloride conductive coating is formed which enhances the signal carrying properties of the electrode.

The elimination of the need for a ridged barrier also permits the formation of a relatively smaller electrode than that of presently available electrodes and permits their use with regions of the body where the larger electrodes have not been readily useable. A smaller size also makes the electrode more convenient for use with child and infant patients.

The invention is described in more detail with reference to the attached drawings wherein

FIG. 1 shows a view in cross-section of a monitoring electrode of the prior art;

FIG. 1A shows a plan view of the electrode of FIG. 1;

FIG. 2 shows a view in cross-section of a preferred embodiment of the electrode in accordance with the invention;

FIG. 2A shows a plan view of the electrode of FIG. 2;

FIG. 3 shows a view in cross-section of a portion of the electrode of FIG. 2; and

FIG. 4 shows a view in cross-section of a preferred embodiment for packaging one or more of the electrodes of FIG. 2.

FIG. 1 depicts a conventional monitoring electrode of the prior art which has found relatively widespread use in the medical field at the present time. As can be seen therein the electrode 10 comprises a solid plastic ridged body member having an upper portion 11A and a lower portion 11B, each of a circular configuration, which portions each include flat body portions 12A and 12B respectively, and ridged portions 13A and 13B, respectively, forming the outer peripheries thereof. A contact element 14 is positioned within apertures at the centers of solid portions 11A and 11B, the contact element being in the form of a conventional male snap fastener having a first upper portion 14A with a protruding snap at the center thereof and a lower portion 14B which nests within the upper portion so that the overall element can be attached to and retained in the solid ridged member. The snap fastener 14 provides a snap contact to a corresponding female snap fastener (not shown) which is in turn connected to an appropriate lead for connection to suitable monitoring equipment (also not shown). The upper and lower solid portions 11A and 11B may be made of any appropriately chosen plastic material and are arranged to enclose an adhesive pad member 16 also of substantially circular configuration, as shown. One side of foam pad 16 has a layer 17 of double faced adhesive material placed thereon and extending from ridge 13B to the periphery thereof so as to provide an adhesion surface which permits the electrode to be placed in an adhering manner on the skin of a patient. A circular pad 19 of foam plastic material is nested within the recess 18 formed by ridge 13B, pad 19 being substantially permeated with a conductive gel substance forming a gel pad for providing a good conductive path from the skin which contacts the outer exposed surface thereof and the lower portion 14B of contact element 14, which is in contact with the inner surface of gel pad 19. Gel pad 19 is retained within the recess 18 by the surface tension action of the gel on the underside of solid plastic portion 12B.

In the prior art structure shown both of the plastic pad materials forming the adhesive pad 16 and the gel pad 19 are made of an open cellular plastic foam material which is readily absorbent to liquids and gels which can thereby penetrate into and become dispersed throughout such materials. In order to permit dispersion of conductive gel throughout gel pad 19 without permitting a similar dispersion in the adhesive pad 16, the ridge 13B and body portion 12B form a barrier so that none of the gel in gel pad 19 comes into contact with the adhesive pad 16. Were the conductive gel to become dispersed throughout adhesive pad 16 as well as gel pad 19, the conductivity of the path through pad 19 would be greatly reduced and the effectiveness of the electrode would become diminished. Further, when the prior art electrode 10 is placed on the skin of a patient for any prolonged period of time, ridge 13B tends

to dig into the skin and become so irritating that a high degree of discomfort may result, particularly with patients having relatively tender skin.

Moreover, when the electrode has been placed on the skin the presence of ridge 13B tends to cause the adhesive surfaces in the regions adjacent the ridges to be raised out of contact with the skin so that the area of adhesive contact with the skin is reduced. In order to assure that the surface area of adhesive contact is sufficient, the diameter of the overall electrode must be made relatively large and the electrode becomes less useful for some applications.

A preferred embodiment of the monitoring electrode of the invention is depicted in FIGS. 2 and 2A and shows the contrast between the structure thereof and that of the prior art electrode shown in FIGS. 1 and 1A.

As can be seen in FIGS. 2 and 2A, the electrode 20 of the invention comprises an adhesive foam pad portion 21 which forms the main body of the electrode and has on one surface thereof a layer 22 of double-faced adhesive which effectively covers the entire surface. In a preferred embodiment adhesive foam pad 21 has a substantially circular configuration and at the central region of the surface 24 opposite to the adhesive surface thereof a paper thin circular piece 23 of vinyl plastic material is positioned. Vinyl piece 23 imparts a slightly greater degree of rigidity for the surface 24 of the electrode than to the adhesive surface thereof and, further, can be used as an appropriate label for identifying the electrode and the manufacturer thereof.

A snap fastener contact element 25 is machine fastened at the center of adhesive foam pad 21 as shown. After the fastening process the presence of fastener 25 forms slight depressions at both the upper and the lower surfaces of foam pad 21, as shown. The peripheral region of a gel pad 26 is caused to adhere to the adhesive surface of pad 21 so that the pad 26 is placed at a position opposite the lower contact surface 25A of contact element 25 as shown in enlarged detail in FIG. 3.

Adhesive foam pad 21 is made of a closed cell plastic material, such as a closed cell polyethylene or polyurethane plastic material, while gel pad 26 is made of an open cell material, such as polyurethane foam material. The use of a closed cell material for pad 21 effectively prevents any penetration through the pad 21 of any conductive gel which is present in gel pad 26 within which it is in contact. One such closed cell plastic successfully used in the electrode of the invention is a polyethylene plastic sold under the name "Volara" by the Voltech Company of Lawrence, Massachusetts. One such open cell gel pad material which has been successfully used to provide the necessary gel dispersion action is a polyurethane foam material sold by Rogers Foam Company, Somerville, Massachusetts.

Further, the double sided adhesive layer 22 is selected so as to avoid causing any irritation to the skin, to which it adheres. One such adhesive which has been successfully used and which has been approved for such use by the Federal Drug Administration of the United States Government is identified as Adhesive No. 1524, made by 3M Company, Minneapolis, Minnesota.

The cellular density of open cell material 26 is such as to be sufficiently dense to hold a conductive gel within the material and at the same time sufficiently po-

rous to allow the gel to penetrate throughout the material so that a good electrical contact is made between the skin of the patient and the lower surface 25A of contact element 25. Conductive gels for this purpose are readily available to those in the art and any convenient gel such as that identified as Spectra 360 as sold by Parker Laboratories, Irvington, New Jersey, may be used in the electrode of the invention.

In order to enhance the conductive path from the skin to the contact element 25, the bottom surface 25A thereof is coated with silver. When the conductive gel comes into contact with the silver coated surface thereof it forms a combination silver/silver chloride coating which enhances the conductive properties therebetween. In using conventional snap fasteners which have chrome plated surfaces, for example, contact with electrode conductive gels often causes the formation of an acid coating which may be injurious to the skin against which the electrode is pressed. The silver/silver chloride coating not only has been found to increase the conductivity of the overall electrode, it has also been found to be essentially harmless to the skin of the patient. It can also be seen that when the electrode is applied to the skin of a patient, gel pad 26 is effectively compressed and the lower surface of the electrode forms an effectively soft and smooth contact with the skin over its entire area and little or no discomfort is felt by the patient.

With reference to the dimensions of the various elements of the electrode of the invention, it has been found that the thickness of the adhesive foam pad 21 preferably lies within a range of from 1/32nd of an inch to about 3/16ths of an inch, with a thickness of about 1/16th of an inch being successfully used in a preferred embodiment of the electrode. The thickness is primarily selected so as to retain sufficient flexibility for the overall electrode to permit it to be used in various skin areas, even those having a relatively deep curvature. Moreover, it has been found that if the adhesive foam pad portion is at least 1/32nd of an inch thick, it becomes much easier to remove the electrode both from the card on which it is shipped, as described below, and from the skin after use.

The vinyl label 23 has been found preferably to have a diameter lying between about 0.75 inches to up to the diameter of the foam pad 16. The latter preferably has a diameter of from about 1 inch to 2 1/4 inches and in a preferred embodiment a diameter of 1 3/8 inches has been found to be satisfactory for use not only on adult patients but also on child and infant patients.

The diameter of gel pad 26 is preferably between about 11/16 inch and 13/16 inch with a diameter of about 3/4 inch being successfully used in a preferred embodiment. Thus, the gel pad must be sufficiently large to cover the bottom contact element surface and yet have enough surface area in contact with the adhesive layer 22 to permit the gel pad to be adequately attached to the foam pad 21 about its entire periphery. Since the gel pad 26 is retained on foam pad 21 by the adhesive layer 22 it does not depend for its retention upon the surface tension of the gel itself. Accordingly, in shipping the overall electrode the electrode can be shipped either in a "dry" form, that is, a form wherein the gel is not applied to the open cell pad 26 until just prior to use, or in a "wet" form, that is, where the gel is applied when the electrode is packaged so that it arrives for use in a "pre-gelled" state. Such a construc-

tion is in contrast with that of the prior art where the gel must be shipped in a "wet" state so as to be retained within the recess 18 of electrode 10, for example.

The electrode may be shipped by affixing one or more of said electrodes to an appropriate card having one or more circular apertures each with a diameter substantially equal to the diameter of the gel pad 26. As can be seen in FIG. 4 the electrodes are adhered to the upper surface of a card 31 by means of adhesive layer 22 with the gel pads 26 extending through apertures 30 thereof below the bottom surface of the card 31. The gel pads are further protected by applying a clear plastic cover member 32 having relatively rigid raised portions 33 positioned above each gel pad 26, as shown. Cover member 32 may be appropriately fastened with adhesive material, such as a suitable glue, at appropriate points on the lower surface of the card.

Each card may be inserted into an hermetically sealed bag 35 which also has a light opaque inner surface. If the electrode is of a pre-gelled form, the hermetically sealed bag prevents the escape of any moisture from the gel and keeps the gel pad 26 in an appropriately "wet" conductive state. The use of a light opaque bag prevents the penetration into the interior of the bag of ultraviolet rays which may cause a deterioration of the adhesive layer 22. Accordingly, when the electrode is ready for use it will adhere firmly to the skin without any problems. The semi-rigid cover 32 prevents the gel pad from being inadvertently squeezed during shipment which action would cause an irretrievable loss of the gel material.

In manufacturing the electrodes of the invention, a sheet of closed cell plastic foam material is covered on one surface thereof with a double sided layer of adhesive material. A plurality of vinyl labels are then adhered at various regions to the opposite side thereof and the snap fasteners 25 are machine installed at the center of each vinyl label. A plurality of open cell foam plastic pads are then adhered to the adhesive layer of the closed cell material at positions opposite each snap fastener. The open cell pads can be so applied in a "dry" state and the electrodes then appropriately punched out from the closed cell plastic sheet. If it is desired to ship the electrodes in a wet state, a conductive gel is applied to each of the gel pads before packaging.

Whether in a wet or in a dry state, one or more of the punched electrodes are mounted on a card having one or more circular apertures each having a diameter the same as that of the open cell gel pads and the relatively rigid plastic cover is then glued to the surface of the card through which the open cell gel pad protrudes. The cards are then placed into hermetically sealable and light opaque bags and appropriately sealed for storage and/or shipment.

What is claimed is:

1. A monitoring electrode comprising a substantially flat support member formed of plastic foam material having a closed cellular configuration throughout, one surface of which is adhesive;

a contact element embedded in said support member, a first contact portion thereof being exposed at said one surface and a second contact portion thereof protruding from the opposite surface of said support member;

a pad member formed of plastic foam material having an open cellular configuration adhered to said adhesive surface of said support member at a position such that the inner surface of said pad member is in contact with and substantially covers said exposed portion of said contact element, the outer surface thereof being capable of contacting a surface to be monitored.

2. A monitoring electrode in accordance with claim 1 and further including  
 a conductive gel being dispersed throughout said pad member when said monitoring electrode is in use to provide a conductive path from said outer surface of said pad member to said second contact portion.

3. A monitoring electrode in accordance with claim 2 and further including  
 a plastic strip adhered to a portion of said opposite surface of said support member to impart greater rigidity to said opposite surface than to said one surface thereof.

4. A monitoring electrode in accordance with claim 2 wherein the thickness of said support member is in a range from about 1/32 inch to about 3/16 inches.

5. A monitoring electrode in accordance with claim 4 wherein the thickness of said support member is about 1/16 inch.

6. A monitoring electrode in accordance with claim 2 wherein the thickness of said pad member is in a range from about 1/32 inch to about 3/32 inches.

7. A monitoring electrode in accordance with claim 6 wherein the thickness of said pad member is about 1/16 inch.

8. A monitoring electrode in accordance with claim 2 wherein  
 said support member is substantially circular in configuration and has a diameter in a range from about 1 inch to about 2.25 inches.

9. A monitoring electrode in accordance with claim 8 wherein  
 said support member is substantially circular in configuration and has a diameter of about 1 3/8 inches.

10. A monitoring electrode in accordance with claim 8 wherein  
 said pad member is substantially circular in configuration and has a diameter in a range from about 11/16 inches to about 13/16 inches.

11. A monitoring electrode in accordance with claim 10 wherein  
 said pad member is substantially circular in configuration and has a diameter of about 3/4 inches.

\* \* \* \* \*

30

35

40

45

50

55

60

65