



(19) **United States**  
(12) **Patent Application Publication**  
**BADIN et al.**

(10) **Pub. No.: US 2016/0102895 A1**  
(43) **Pub. Date: Apr. 14, 2016**

(54) **MODULAR AIR COOLED CONDENSER FLOW CONVERTER APPARATUS AND METHOD**

(21) Appl. No.: 14/509,687

(22) Filed: **Oct. 8, 2014**

(71) Applicants: **Francis BADIN**, Binche (BE); **Christophe DELEPLANQUE**, Brussels (BE); **Fabien FAUCONNIER**, Brussels (BE); **Thomas Van QUICKELBERGHE**, Wannebecq (Lessines) (BE); **Francois Van RECHEM**, Brussels (BE); **Michel VOUCHE**, Marbais (BE)

**Publication Classification**

(51) **Int. Cl.**  
**F25B 41/00** (2006.01)  
**F25B 39/00** (2006.01)  
(52) **U.S. Cl.**  
CPC ..... **F25B 41/00** (2013.01); **F25B 39/00** (2013.01); **F25B 39/04** (2013.01)

(72) Inventors: **Francis BADIN**, Binche (BE); **Christophe DELEPLANQUE**, Brussels (BE); **Fabien FAUCONNIER**, Brussels (BE); **Thomas Van QUICKELBERGHE**, Wannebecq (Lessines) (BE); **Francois Van RECHEM**, Brussels (BE); **Michel VOUCHE**, Marbais (BE)

(57) **ABSTRACT**

The present invention relates to a mechanical draft cooling tower that employs air cooled condenser modules. The aforementioned cooling tower operates by mechanical draft and achieves the exchange of heat between two fluids such as atmospheric air, ordinarily, and another fluid which is usually steam. The aforementioned cooling tower utilizes a modular air cooled condenser concept wherein the air cooled condensers utilize heat exchange deltas and uniquely designed fluid flow dividers.

(73) Assignee: **SPX COOLING TECHNOLOGIES, INC.**, Overland Park, KS (US)

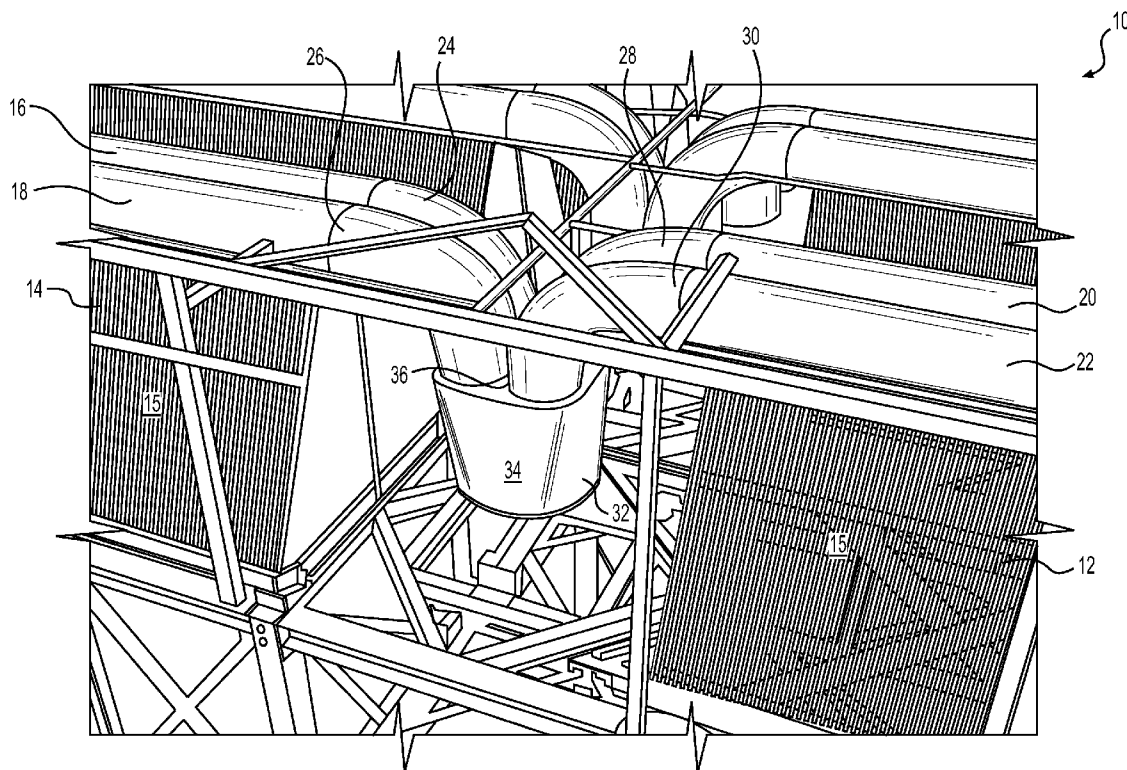

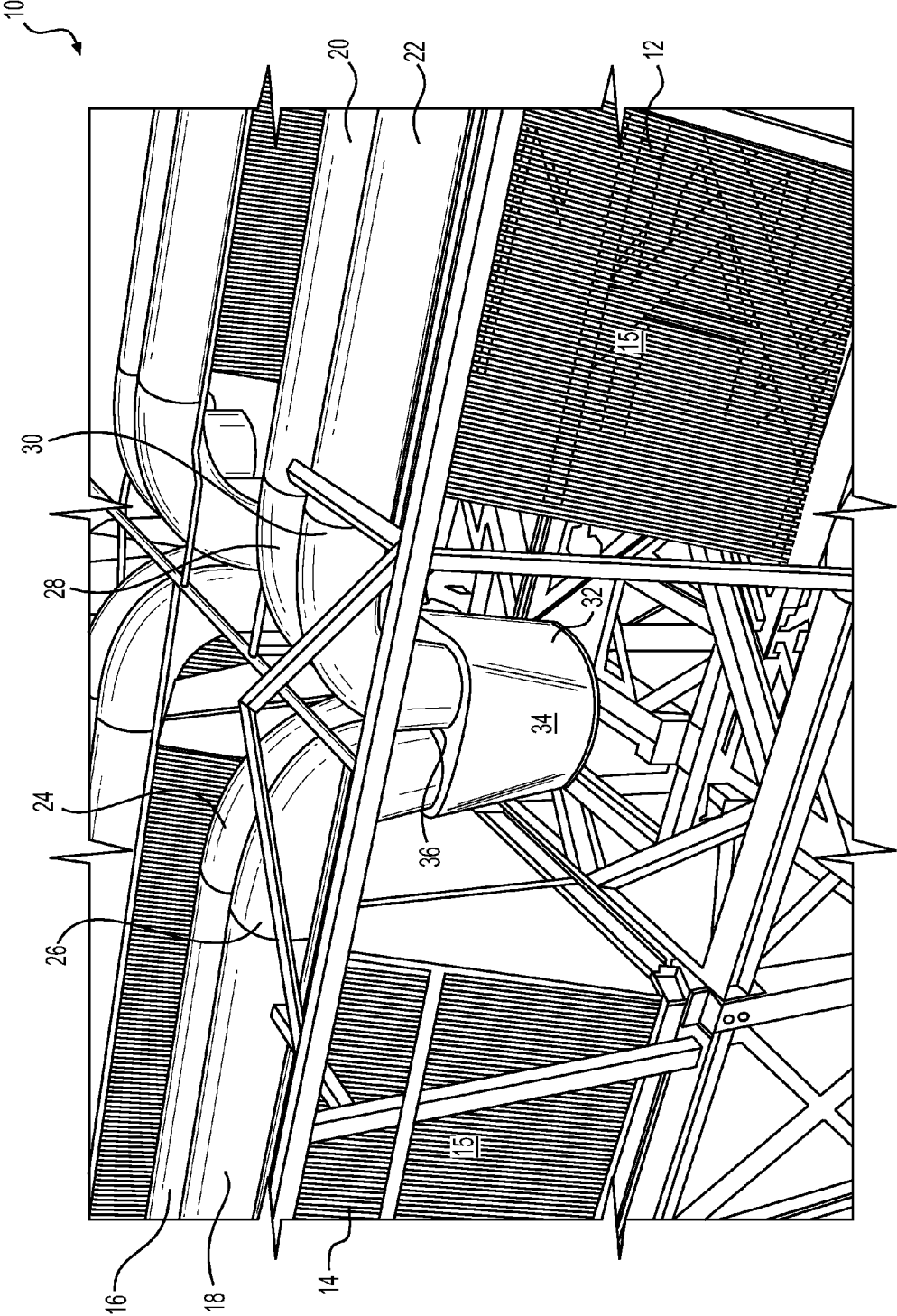
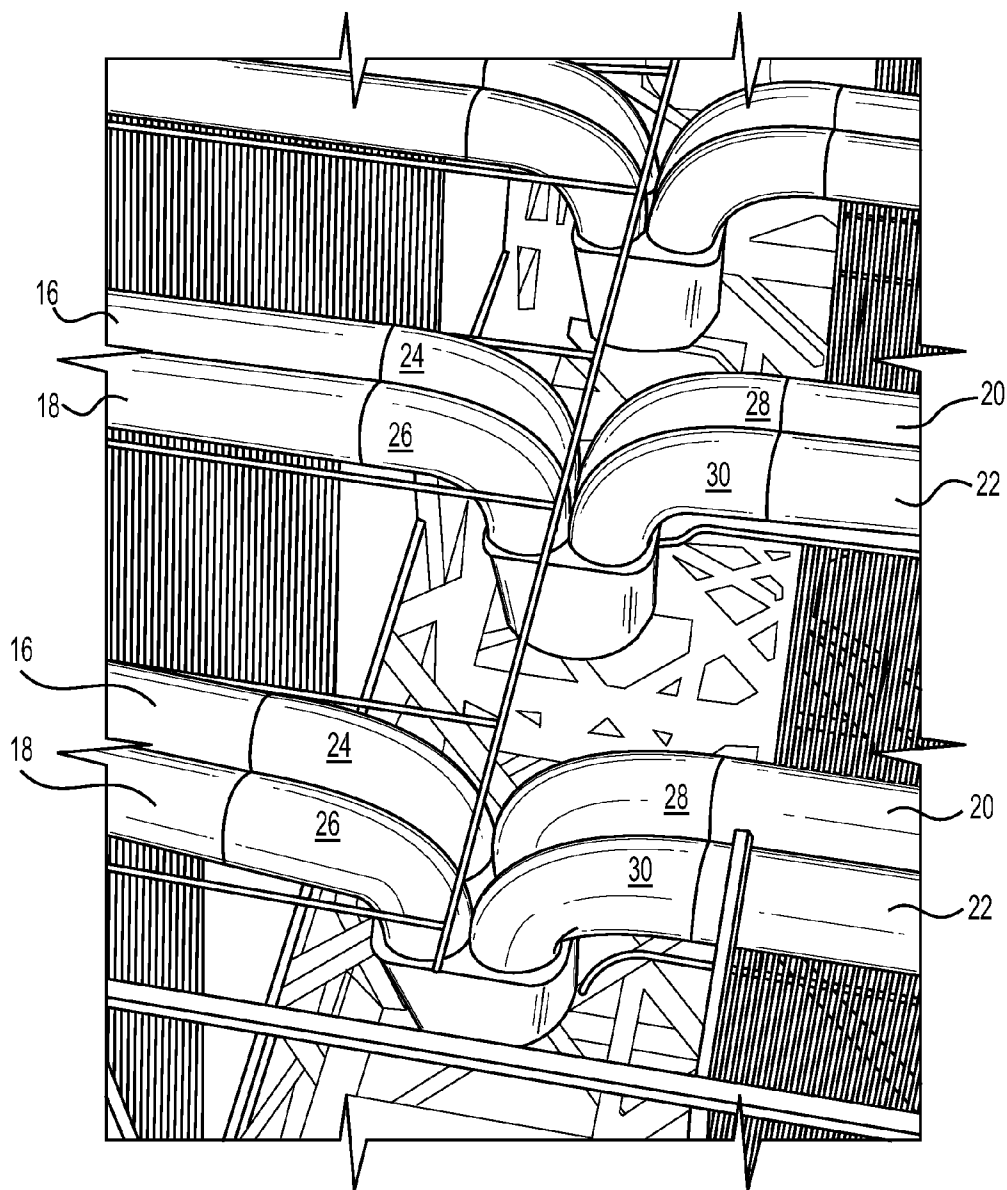
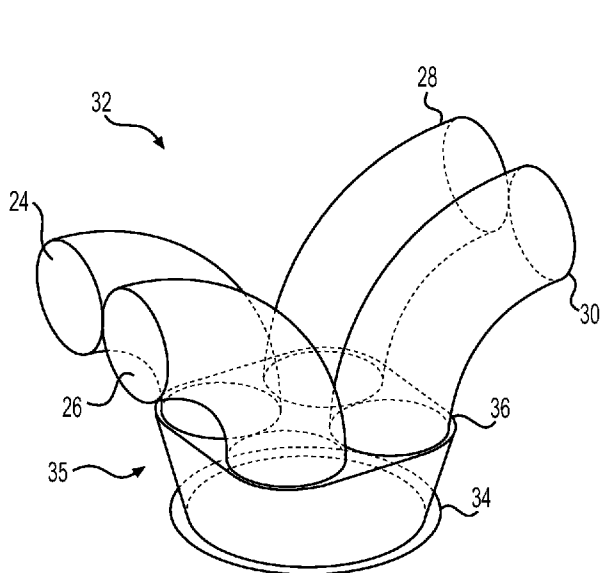

FIG. 1



**FIG. 2**



**FIG. 3**

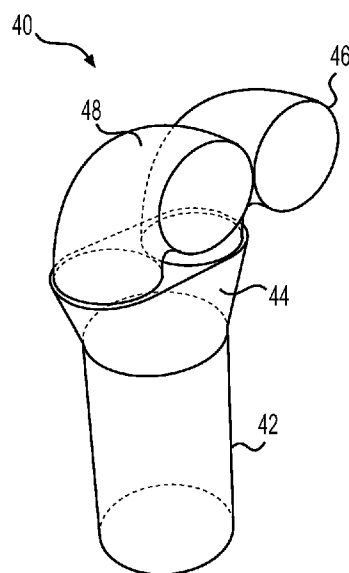

**FIG. 4**

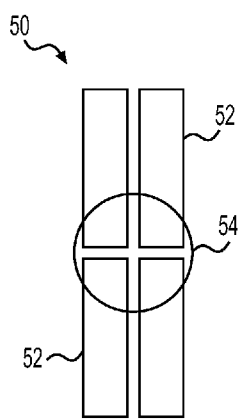

**FIG. 5**

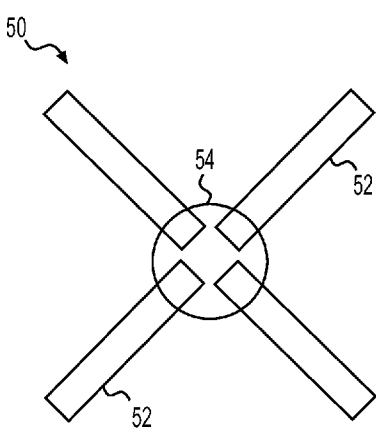

**FIG. 6**

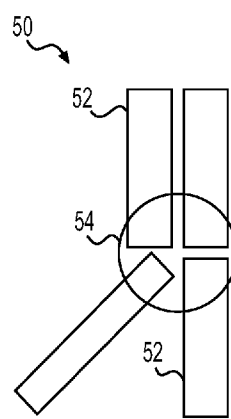

**FIG. 7**

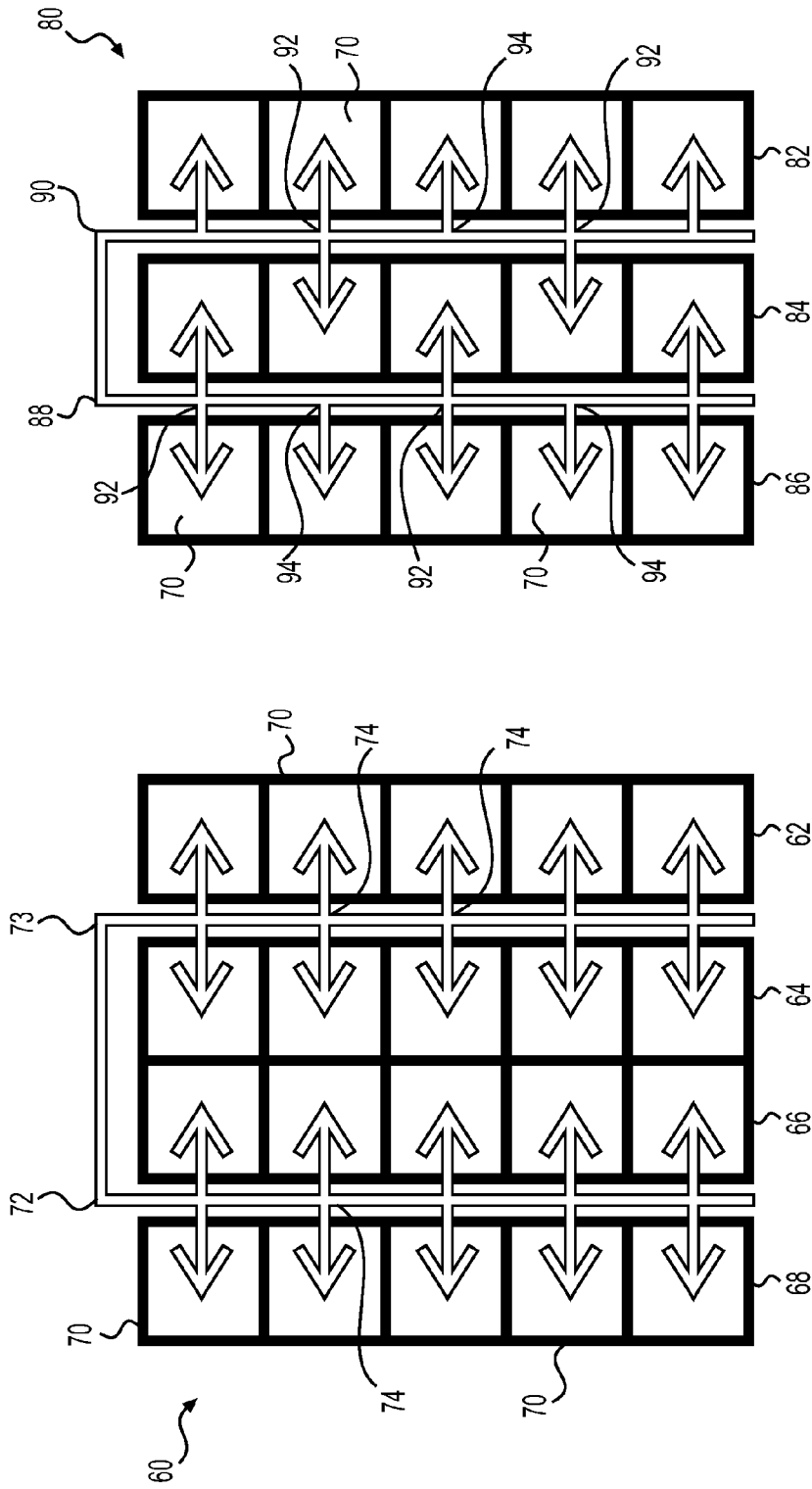
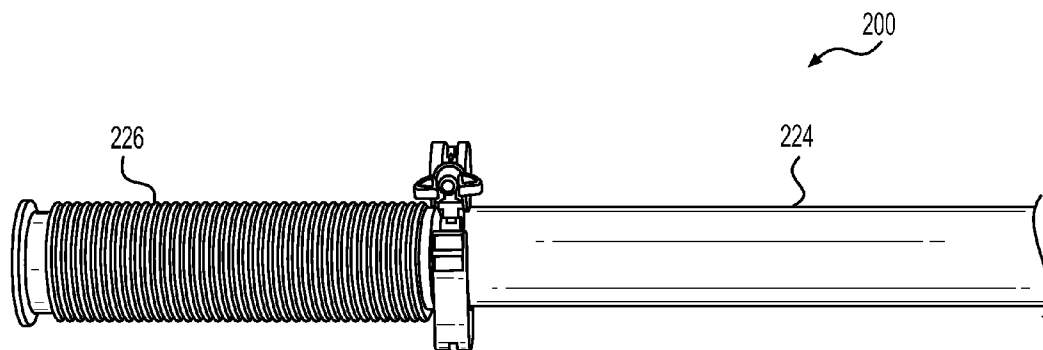
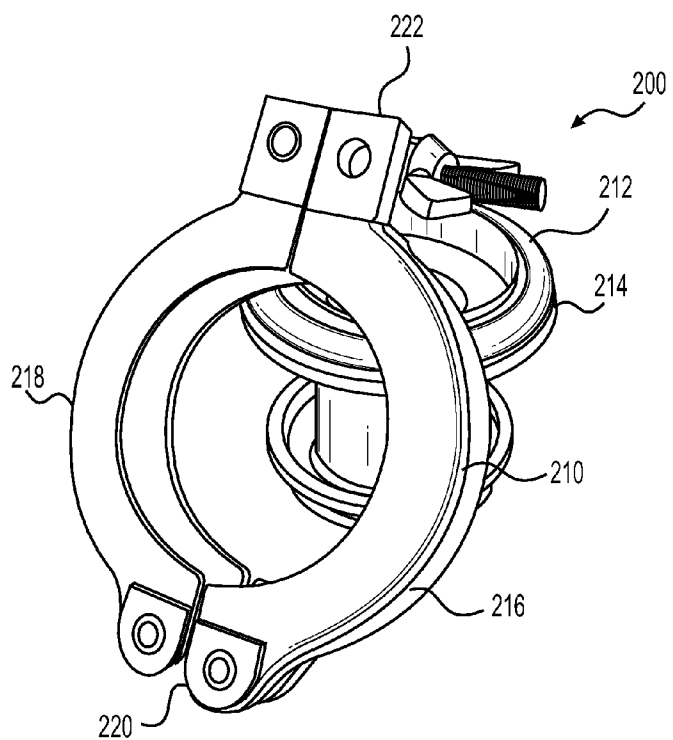

FIG. 9

FIG. 8



**FIG. 10**



**FIG. 11**

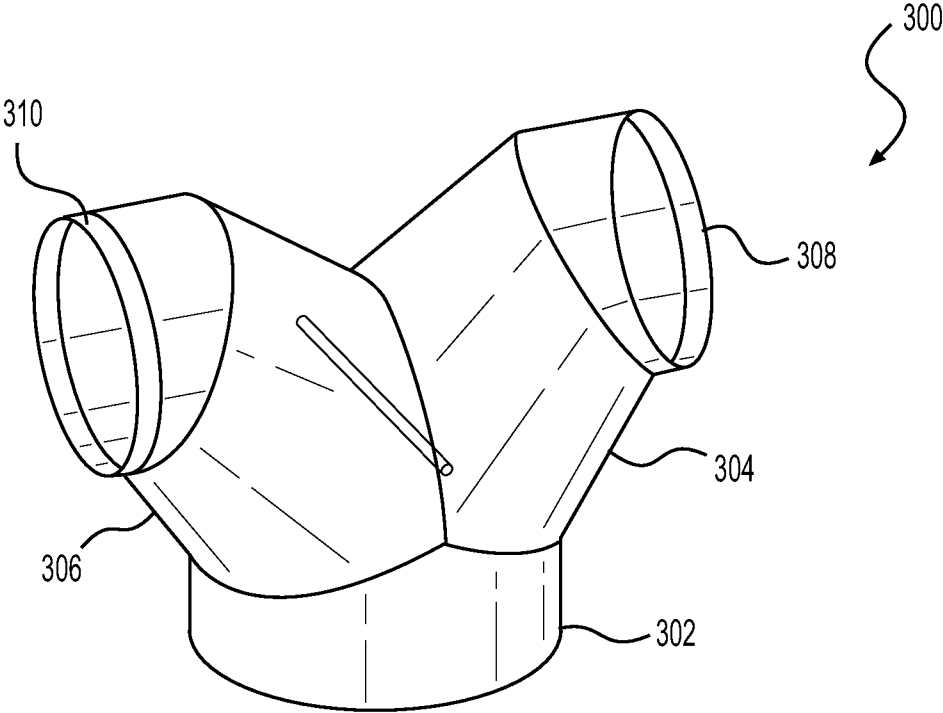

**FIG. 12**

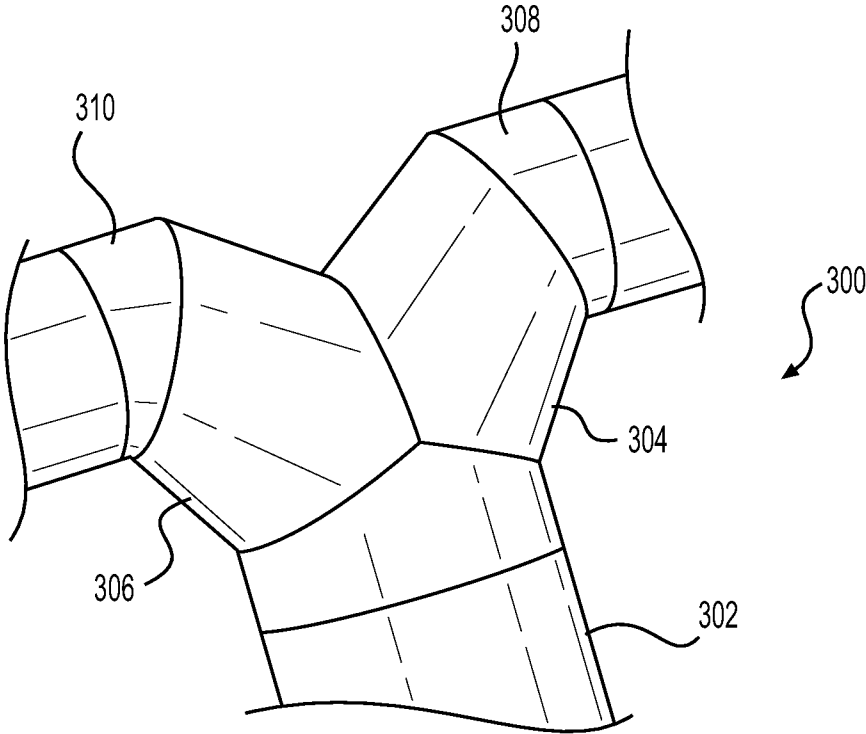

**FIG. 13**

## MODULAR AIR COOLED CONDENSER FLOW CONVERTER APPARATUS AND METHOD

### FIELD OF THE INVENTION

[0001] The present invention relates to a mechanical draft cooling tower that utilizes air cooled condenser modules. The aforementioned cooling tower operates by mechanical draft and achieves the exchange of heat between two fluids such as atmospheric air, ordinarily, and another fluid which is usually steam or an industrial process fluid or the like. The aforementioned cooling tower employs flow dividers that allow for the industrial process fluid to be flowed to multiple tube bundles located in the condenser modules efficiently and economically.

### BACKGROUND OF THE INVENTION

[0002] Cooling towers are heat exchangers of a type widely used to emanate low grade heat to the atmosphere and are typically utilized in electricity generation, air conditioning installations and the like. In a mechanical draft cooling tower for the aforementioned applications, airflow is induced or forced via an air flow generator such as a driven impeller, driven fan or the like. Cooling towers may be wet or dry. Dry cooling towers can be either "direct dry," in which steam is directly condensed by air passing over a heat exchange medium containing the steam or an "indirect dry" type cooling towers, in which the steam first passes through a surface condenser cooled by a fluid and this warmed fluid is sent to a cooling tower heat exchanger where the fluid remains isolated from the air, similar to an automobile radiator. Dry cooling has the advantage of no evaporative water losses. Both types of dry cooling towers dissipate heat by conduction and convection and both types are presently in use. Wet cooling towers provide direct air contact to a fluid being cooled. Wet cooling towers benefit from the latent heat of vaporization which provides for very efficient heat transfer but at the expense of evaporating a small percentage of the circulating fluid.

[0003] To accomplish the required direct dry cooling the condenser typically requires a large surface area to dissipate the thermal energy in the gas or steam and oftentimes may present several challenges to the design engineer. It sometimes can be difficult to efficiently and effectively direct the steam to all the inner surface areas of the condenser because of non-uniformity in the delivery of the steam due to system ducting pressure losses and velocity distribution. Therefore, uniform steam distribution is desirable in air cooled condensers and is critical for optimum performance. Another challenge or drawback is, while it is desirable to provide a large surface area, steam side pressure drop may be generated thus increasing turbine back pressure and consequently reducing efficiency of the power plant. Therefore it is desirable to have a condenser with a strategic layout of ducting and condenser surfaces that allows for an even distribution of steam throughout the condenser, that reduces back pressure, while permitting a maximum of cooling airflow throughout and across the condenser surfaces.

[0004] Another drawback to the current air cooled condenser towers is that they are typically very labor intensive in their assembly at the job site. The assembly of such towers oftentimes requires a dedicated labor force, investing a large amount of hours. Accordingly, such assembly is labor inten-

sive requiring a large amount of time and therefore can be costly. Accordingly, it is desirable and more efficient to assemble as much of the tower structure at the manufacturing plant or facility, prior to shipping it to the installation site.

[0005] It is well known in the art that improving cooling tower performance (i.e. the ability to extract an increased quantity of waste heat in a given surface) can lead to improved overall efficiency of a steam plant's conversion of heat to electric power and/or to increases in power output in particular conditions. Moreover, cost-effective methods of manufacture and assembly also improve the overall efficiency of cooling towers in terms of cost-effectiveness of manufacture and operation. Accordingly, it is desirable for cooling tower that are efficient in both in the heat exchange properties and assembly. The present invention addresses this desire.

[0006] Therefore it would be desirable to have an economical, mechanical draft cooling tower that is efficient not only in its heat exchange properties but also in its time required for assembly and cost for doing the same while minimizing steamside pressure drop relating to the ducting of said cooling tower.

### SUMMARY OF THE INVENTION

[0007] Embodiments of the present invention advantageously provides for a fluid, usually steam and method for a modular mechanical draft cooling tower for condensing said steam.

[0008] In one embodiment of the present invention, a flow divider for the distribution of a flow of industrial fluid for use in an air cooled condenser or the like having a vertical axis, the flow divider comprising: a cylindrical lower base portion that receives the flow of industrial fluid; an upper diffusion region that extends from said cylindrical base portion wherein said upper diffusion region is generally non-cylindrical in geometry; a first port disposed on said upper diffusion region that allows for the flow of industrial fluid there through; and a first conduit connected to said first port.

[0009] In another embodiment of the present invention, an air cooled condenser for cooling an industrial fluid is provided, comprising: a first condenser bundle having a first set of tubes having first and second ends; a steam manifold connected to the third ends of the first set tubes; a condensate header connected to said fourth end of the first set tubes; a second condenser bundle having a second set of tubes having third and fourth ends; a steam manifold connected to the first ends of the second set tubes; a condensate header connected to said second end of the second set tubes; a flow divider for the distribution of a flow of industrial fluid comprising: a cylindrical lower base portion that receives the flow of industrial fluid; an upper diffusion region that extends from said cylindrical base portion wherein said upper diffusion region is generally non-cylindrical in geometry; a first port disposed on said upper diffusion region that allows for the flow of industrial fluid there through; a second port disposed on said upper diffusion region that allows for the flow of industrial fluid there through and a first conduit connected to said first port and said first set of tubes; and a second conduit connected to said second port and said first set of tubes.

[0010] In yet another embodiment of the present invention, a method for distributing a fluid to be cooled using a flow divider is provided, comprising: receiving the fluid to be cooled through a cylindrical lower base portion that; flowing the fluid to be cooled through an upper diffusion region that extends from said cylindrical base portion wherein said upper



diffusion region is generally non-cylindrical in geometry; flowing the fluid to be cooled through a first port disposed on said upper diffusion region; and flowing the fluid to be cooled through a first conduit connected to said first port.

**[0011]** In still another embodiment of the present invention, a flow divider for use with an air cooled condenser or the like is provided, comprising: means for receiving the fluid to be cooled through a cylindrical lower base portion; means for flowing the fluid to be cooled through an upper diffusion region that extends from said cylindrical base portion wherein said upper diffusion region is generally non-cylindrical in geometry; means for flowing the fluid to be cooled through a first port disposed on said upper diffusion region; and means for flowing the fluid to be cooled through a first conduit connected to said first port.

**[0012]** In another embodiment of the present invention, a multi-delta air cooled condenser for cooling an industrial fluid or the like is provided, comprising: a first street that comprises a first air cooled condenser module; a second street comprising a second air cooled condenser module; a first central duct that is in fluid communication with said first air cooled condenser module and said second air cooled condenser module; a third street comprising a third air cooled condenser module; a second central duct that is in fluid communication with said third air cooled condenser module; a first flow divider connected to said first central duct, comprising: a cylindrical lower base portion that receives the flow of industrial fluid; an upper diffusion region that extends from said cylindrical base portion wherein said upper diffusion region is generally non-cylindrical in geometry; a first port disposed on said upper diffusion region that allows for the flow of industrial fluid there through; and a first conduit connected to said first port, wherein said first conduit is in fluid communication with said first air cooled condenser module; a second port disposed on said upper diffusion region that allows for the flow of industrial fluid there through; and a second conduit connected to said first port, wherein said first conduit is in fluid communication with said second air cooled condenser module; a second flow divider connected to said second central duct, comprising: a cylindrical lower base portion that is receives the flow of industrial fluid; an upper diffusion region that extends from said cylindrical base portion wherein said upper diffusion region is generally non-cylindrical in geometry; a third port disposed on said upper diffusion region that allows for the flow of industrial fluid there through; and a third conduit connected to said third port, wherein said third conduit is in fluid communication with said third air cooled condenser module.

**[0013]** In still another embodiment of the present invention, a quick connection coupling for use with an air cooled condenser is provided, comprising: a collar having a first half and; a second half hingedly connected to said first half; an internal sealing piece having a circumference that is disposed within said first half and said second half; a sealing member that encircles the circumference; and a releasable attachment member that releasably attaches said first half to said second half

**[0014]** In an embodiment of the present invention, a method of retaining a first conduit and a second conduit wherein each conduit has a flange is provided, comprising: inserting the first and second conduit into a connection coupling, comprising: a collar having a first half; a second half hingedly connected to said first half; an internal sealing piece having a circumference that is disposed within said first half and said

second half; a sealing member that encircles the circumference; and a releasable attachment member that releasably attaches said first half to said second half; encircling each conduit with the internal sealing piece; engaging each flange with the first half and the second half such that the conduits are retained; and tightening the attachment member such that the collar sealingly retains the conduits.

**[0015]** In still another embodiment of the present invention, a flow divider for the distribution of a flow of industrial fluid for use in an air cooled condenser or the like having a vertical axis is provided, the flow divider comprising: a cylindrical lower base portion that provides an inlet that receives the flow of industrial fluid, wherein said cylindrical base portion has a first diameter; a first truncated cone extending from said lower base portion wherein said first truncated cone has a first end and a second end and wherein said first truncated cone transitions from one diameter to another as said cone extends from said first end to said second end; a second truncated cone extending from said lower base portion wherein said second truncated cone has a third end and a fourth end and wherein said second truncated cone transitions from one diameter to another as said cone extends from said third end to said fourth end; a first conduit connected to said first truncated cone, wherein said first conduit has a second diameter; and a second conduit connected to said second truncated cone, wherein said second conduit has a third diameter.

**[0016]** In another embodiment of the present invention, an air cooled condenser for cooling an industrial fluid is provided, comprising: a first condenser bundle having a first set of tubes having first and second ends; a steam manifold connected to the first ends of the first set tubes; a condensate header connected to said second end of the first set tubes; a second condenser bundle having a second set of tubes having first and second ends; a steam manifold connected to the first ends of the second set tubes; a condensate header connected to said second end of the second set tubes; a flow divider, comprising: a cylindrical lower base portion that provides an inlet that receives the flow of industrial fluid, wherein said cylindrical base portion has a first diameter; a first truncated cone extending from said lower base portion wherein said first truncated cone has a first end and a second end and wherein said first truncated cone transitions from one diameter to another as said cone extends from said first end to said second end; a second truncated cone extending from said lower base portion wherein said second truncated cone has a third end and a fourth end and wherein said second truncated cone transitions from one diameter to another as said cone extends from said third end to said fourth end; a first conduit connected to said first truncated cone, wherein said first conduit has a second diameter and is in fluid communication with said first tube bundle; and a second conduit connected to said second truncated cone, wherein said second conduit has a third diameter and is in fluid communication with said second tube bundle.

**[0017]** In yet another embodiment of the present invention, a method of retaining a first conduit and a second conduit wherein each conduit has a flange is provided, comprising: inserting the first and second conduit into a connection coupling, comprising: a collar having a first half; a second half hingedly connected to said first half; an internal sealing piece having a circumference that is disposed within said first half and said second half; a sealing member that encircles the circumference; and a releasable attachment member that releasably attaches said first half to said second half; encir-

cling each conduit with the internal sealing piece; engaging each flange with the first half and the second half such that the conduits are retained; and tightening the attachment member such that the collar sealingly retains the conduits.

[0018] There has thus been outlined, rather broadly, certain embodiments of the invention in order that the detailed description thereof herein may be better understood, and in order that the present contribution to the art may be better appreciated. There are, of course, additional embodiments of the invention that will be described below and which will form the subject matter of the claims appended hereto.

[0019] In this respect, before explaining at least one embodiment of the invention in detail, it is to be understood that the invention is not limited in its application to the details of construction and to the arrangements of the components set forth in the following description or illustrated in the drawings. The invention is capable of embodiments in addition to those described and of being practiced and carried out in various ways. Also, it is to be understood that the phraseology and terminology employed herein, as well as the abstract, are for the purpose of description and should not be regarded as limiting.

[0020] As such, those skilled in the art will appreciate that the conception upon which this disclosure is based may readily be utilized as a basis for the designing of other structures, methods and systems for carrying out the several purposes of the present invention. It is important, therefore, that the claims be regarded as including such equivalent constructions insofar as they do not depart from the spirit and scope of the present invention.

#### BRIEF DESCRIPTION OF THE DRAWINGS

[0021] The above-mentioned and other features and advantages of this disclosure, and the manner of attaining them, will become more apparent and the disclosure itself will be better understood by reference to the following description of various embodiments of the disclosure taken in conjunction with the accompanying figures.

[0022] FIG. 1 is a perspective view of an air cooled condenser modules in accordance with an embodiment of the present invention.

[0023] FIG. 2 is a perspective, plan view of the air cooled condenser modules depicted in FIG. 1 in accordance with an embodiment of the present invention.

[0024] FIG. 3 is a perspective view of a fluid flow divider in accordance with an embodiment of the present invention.

[0025] FIG. 4 is a perspective view of an alternative embodiment of a fluid flow divider in accordance with an embodiment of the present invention.

[0026] FIG. 5 is a schematic view of a flow divider geometry in accordance with an embodiment of the present invention.

[0027] FIG. 6 is a schematic view of a flow divider geometry in accordance with another embodiment of the present invention.

[0028] FIG. 7 is a schematic view of a flow divider geometry in accordance with yet another embodiment of the present invention.

[0029] FIG. 8 is a schematic depiction of a street configuration for an air cooled condenser in accordance with an embodiment of the present invention.

[0030] FIG. 9 is a schematic depiction of a street configuration for an air cooled condenser in accordance with another embodiment of the present invention.

[0031] FIG. 10 is a perspective view of a quick connection for an air cooled condenser in accordance with an embodiment of the present invention.

[0032] FIG. 11 is a perspective view of a clamp of the quick connection depicted in FIG. 10.

[0033] FIG. 12 is a perspective view of a flow divider in accordance with an alternative embodiment of the present invention.

[0034] FIG. 13 is another perspective view of the flow divider depicted in FIG. 12.

#### DETAILED DESCRIPTION OF THE INVENTION

[0035] In the following detailed description, reference is made to the accompanying drawings, which form a part hereof and show by way of illustration specific embodiments in which the invention may be practiced. These embodiments are described in sufficient detail to enable those skilled in the art to practice them, and it is to be understood that other embodiments may be utilized, and that structural, logical, processing, and electrical changes may be made. It should be appreciated that any list of materials or arrangements of elements is for example purposes only and is by no means intended to be exhaustive. The progression of processing steps described is an example; however, the sequence of steps is not limited to that set forth herein and may be changed as is known in the art, with the exception of steps necessarily occurring in a certain order.

[0036] Turning now to FIG. 1, a sectional view of a series of air cooled condenser modules of an air cooled condenser, generally designated 10, is illustrated. The air cooled condenser modules 10 include multiple A-type geometry deltas, each designated 12 and 14 respectively. Two deltas are identified for ease of description and explanation however the condenser modules employ numerous deltas depending upon the size of the air cooled condenser tower and/or the application of the air cooled condenser tower. Each delta 12, 14 comprises two tube bundle assemblies 15 having a series of finned tubes to conduct heat transfer. The deltas 12, 14 will be discussed in further detail below.

[0037] Referring now to FIGS. 1-3, the flow divider, generally designated 32, is depicted. Whereas the flow divider 32 is illustrated in combination with the A-type deltas in FIGS. 1 and 2, the flow divider 32 is illustrated in isolation in FIG. 3 so as all the components and geometry can be easily viewed and described. In the embodiment depicted FIGS. 1-3, the flow divider 32 functions to feed four finned tube bundles 15 (two bundles per delta 12, 14). As illustrated, the flow divider 32 comprises a base portion, generally designated 35, from which a series of conduits 24, 26, 28, 30 extend. Each conduit 24, 26, 28, 30 has a curved "elbow" shape design and connects to a respective feed conduit 16, 18, 20, 22. Each of the feed conduits 16, 18, 20, 22 is connected to, and in fluid communication with, the A-type deltas 12, 14, and more specifically, the finned tube bundles 15.

[0038] The flow divider 32 is comprised of two portions or regions having geometries or designs distinct from one another. The flow divider 32 has a lower cylindrical base portion or region 34 wherein the main flow of the industrial fluid enters said fluid divider 32. The lower base portion or region 34 transitions to a diffusion region 36 which has a generally square geometry. As depicted in FIGS. 1-3, and more specifically in FIG. 3, the diffusion section 36 includes several holes or ports that coincide with the elbow conduits 24, 26, 28, 30 wherein each allows for the flow of industrial

fluid there through. A typical air cooled condenser employs risers to which each flow divider **32** is connected and accordingly allows flow of industrial fluid, such as steam, there through. The risers are connected to a main steam duct of the air cooled condenser.

**[0039]** The flow divider **32** functions to divide and/or merge the flows of the industrial fluid by switching inlet and outlet conduits extending from said divider **32**. The divider **32** may have any number of dividing or merging flows depending upon the size and application of the divider **32**. Moreover, the flow divider **32** may employ guiding vanes within the base portion **34** and/or the diffusion region **36** which assist the reduction of head loss. Also, the elbow conduits may vary in design and geometry. For example, some embodiments may employ standard elbow conduits, or short elbow conduits or mitered elbow conduits. Alternatively, “T” piece or “Y” fork designs may be utilized.

**[0040]** Turning back to FIG. 1, a delta **12**, **14** will be described in further detail. As depicted, each delta **12**, **14** is comprised of two individual heat exchange bundle assemblies **15**, each having a series of finned tubes. The individual tubes are approximately two (2) meters in length whereas the bundle length is approximately twelve (12) meters. As illustrated, each bundle assembly **15** is positioned at an angle to one another to form the A-type configuration of the delta **12**, **14**. While the bundle assemblies **15** may be positioned at any desired angle, they preferably are positioned at an angle approximately twenty degrees (20°) to approximately thirty degrees (30°) from vertical and approximately sixty degrees (60°) to approximately seventy degrees (70°) from horizontal. More specifically, the bundle assemblies **15** are positioned at twenty-six degrees (26°) from vertical and sixty-four degrees (64°) from horizontal.

**[0041]** Each of the bundle assemblies **15** may be assembled prior to shipping wherein each typically comprises a riser to header transition piece, steam manifold, finned tubes, and steam condensate headers. The embodiments of the current invention can utilize five (5) times the tubes, and also employ condenser tubes that are much shorter in length. As result of the aforementioned design and orientation, the steam velocity traveling through the tube bundles **15** is reduced as result of the increased number of tubes in combination with the reduced tube length, and therefore steam pressure drop within the deltas **12**, **14** is reduced, making the air cool condenser **10** more efficient.

**[0042]** Turning now to FIG. 4, an alternative embodiment of the flow divider is depicted, generally designated **40**. Whereas the flow divider design depicted in FIGS. 1-3 employs four elbow conduits **24**, **26**, **28**, **30**, the flow divider **40** depicted in FIG. 4 employs two elbow conduits **46**, **48**. Like the embodiment illustrated in FIGS. 1-3, the flow divider has a lower cylindrical base portion or region **42** wherein the main flow of the industrial fluid enters said fluid divider **40**. The lower base portion or region **42** transitions to a diffusion region **44**, similar to that described in connection with FIGS. 1-3, having a geometry that is generally rectangular in design. As illustrated in FIG. 4, the diffusion section **44** includes two holes or ports that coincide with elbow conduits **46**, **48** and allow for flow of industrial fluid there through.

**[0043]** Referring now to FIGS. 5-7 plan views of alternative geometric configurations of flow dividers **50** are depicted. As illustrated, the elbow flow conduits, generally **52**, may be oriented in multiple configurations as desired or needed per the air cooled condenser application. FIG. 5 illustrates the

flow conduits **52** in a symmetrical orientation, parallel to one another whereas FIG. 6 illustrates the flow conduits **52** positioned equidistant from one another about the flow divider **54**. Finally, FIG. 7 depicts a non-symmetrical orientation. Moreover, the flow conduits may be non-symmetrical in diameter wherein in one embodiment of the present invention, the size of the conduits may be smaller in diameter whereas other conduits may be larger in diameter.

**[0044]** Turning now to FIG. 8, a schematic view of street arrangements, generally designated **60**, for an air cooled condenser is illustrated in accordance with an embodiment of the present invention. FIG. 8 depicts a top view for an even number of streets, **62**, **64**, **66**, **68** whereas FIG. 9 illustrates an air cooled condenser set up having an odd number which will be discussed in more detail below. Referring back to FIG. 8, the streets **62**, **64**, **66**, **68** are comprised of a series of cooling modules or cells **70**. The cooling modules **70** are connected to, and in fluid communication with, the central duct **72** and **73** which flows industrial process fluid to the modules **70** to be cooled. The modules **70** comprise of multiple A-type geometry deltas similar to those discussed in connection with FIG. 1. Each delta **12**, **14** comprises two tube bundle assemblies **15** (See FIG. 1) with a series of finned tubes to conduct heat transfer. Not shown is the process feeding the process fluid to the central duct **72**, **73** such as exhaust steam from steam turbines.

**[0045]** As illustrated in FIG. 8, the fluid to be cooled flows to each cell **70** via the central duct **72**, **73** as previously described. The industrial fluid, such as turbine exhaust, is distributed to the central duct **72**, **73** which is typically suspended under the air cooled condenser fan deck level. The central duct **72**, **73** feeds the two streets **62**, **64** and **66**, **68** as indicated by the arrows through a series of risers and flow dividers, similar to those described in connection with FIG. 2. The flow dividers, which are designated schematically by reference numeral **74**, function to feed four (4) finned tube bundles **15** (two bundles per delta **12**, **14**) as discussed in connect with FIGS. 1-3. As previously described, each flow divider **74** comprises a base portion, from which a series of four conduits extend where two conduits feed one module **70**, one conduit for each side of the A-type geometry delta, and the two other conduits feed the opposing cell, again, one conduit for each side of the A-type geometry delta. As previously described, each conduit has a curved “elbow” shape design and connects to a respective feed conduit. Each of the feed conduits is connected to, and in fluid communication with the A-type deltas, and more specifically, the finned tube bundles.

**[0046]** Each of the flow dividers **74** is composed to two portions or regions having geometries or designs distinct from one another as previously discussed and described. The fluid flow divider **74** has a lower cylindrical base portion or region **34** wherein the main flow of the industrial fluid enters said fluid divider **74**. The lower base portion or region **34** transitions to a diffusion region which has a generally square geometry. This diffusion section includes several holes or ports that coincide with the elbow conduits and allow for flow of industrial fluid there through.

**[0047]** Turning now to FIG. 9, whereas FIG. 8 depicted an air cooled condenser **60** with an even number of streets **62**, **64**, **66**, **68**, FIG. 9 depicts a schematic plan view of an air cooled condenser **80** having an odd or non-even number of streets **82**, **84**, **86**. The streets **82**, **84**, **86** are comprised of a series of cooling modules or cells **70** similar to those discussed in

connection with FIG. 8. The cooling modules 70 are connected to, and in fluid communication with, the central duct 88 and 90 which flows industrial process fluid to the modules 70 to be cooled. The modules comprise of multiple A-type geometry deltas as discussed in connection with FIG. 1. Each delta 12, 14 comprises two tube bundle assemblies 15 with a series of finned tubes to conduct heat transfer. The cooling modules 70 are connected to, and in fluid communication with, the central duct 88, 90 that flows industrial process fluid to the modules 70 to be cooled (See FIG. 1). The modules include multiple A-type geometry deltas as discussed in connection with FIG. 1. Each delta 12, 14 comprises two tube bundle assemblies 15 with a series of finned tubes to conduct heat transfer. Not shown is the process feeding the process fluid to the central duct 88, 90 such as exhaust steam from steam turbines.

[0048] Similar to the embodiment discussed in connection with FIG. 8, the fluid to be cooled flows to each module 70 via the central duct 88, 90 as previously described. The industrial fluid, such as turbine exhaust, is distributed to the central duct 88, 90 which is typically suspended under the air cooled condenser fan deck level. As illustrated in FIG. 9 the central duct 88 feeds streets 84 and 86, while the central duct 90 feeds streets 82 and 84 as indicated by the arrows. The aforementioned flow is achieved through a series of risers and flow dividers, similar to those described in connection with FIGS. 3 and 4. The flow dividers, which are designated schematically at the intersection of the central ducts and the arrows, reference numerals 92 and 94. Each functions to feed finned tube bundles 15 as discussed in connect with FIGS. 1-3. As can be seen in FIG. 9, the flow dividers designated with reference numeral 92 feed two streets, streets 84 and 86 or streets 82 and 84 whereas the flow dividers 94 feed a single street.

[0049] The flow dividers 92 will be described in connection with the embodiment depicted in FIGS. 1-3, wherein each comprises a base portion, generally designated 35, from which a series of conduits 24, 26, 28, 30 extend. Each conduit 24, 26, 28, 30 has a curved "elbow" shape design and connects to a respective feed conduit 16, 18, 20, 22. Each of the feed conduits 16, 18, 20, 22 is connected to, and in fluid communication with the A-type deltas 12, 14, and more specifically, the finned tube bundles 15.

[0050] The flow divider 92 is composed to two portions or regions having geometries or designs distinct from one another. The flow divider 92 has a lower cylindrical base portion or region 34 wherein the main flow of the industrial fluid enters said flow divider 92. The lower base portion or region 34 transitions to a diffusion region 36 which has a generally square geometry. As depicted in FIG. 3, the diffusion section 36 includes several holes or ports that coincide with the elbow conduits 24, 26, 28, 30 and allow for flow of industrial fluid there through. A typical air cooled condenser employs risers to which the flow divider 32 is connected and accordingly allows flow of industrial fluid, such as steam, there through. The risers are connected to a main steam duct.

[0051] The flow divider 92 functions to divide and/or merge the flows by switching inlet and outlet conduits extending from said divider 92. The divider 92 may have any number of dividing or merging flows depending upon the size and application. Moreover, the flow divider 92 may employ guiding vanes within the base portion 34 and/or diffusion region 36 which assist the reduction of head loss. Also, the elbow conduits may vary in design and geometry. For example, some

embodiments may employ standard elbow conduits, or short elbow conduits or mitered elbow conduits.

[0052] Turning now to the flow dividers designated by the reference numeral 94, said flow dividers are similar to the embodiment illustrated in FIG. 4 and will be described in connection with FIG. 4. Whereas the flow divider design depicted in FIGS. 1-3 employs four elbow conduits 24, 26, 28, 30, the flow divider 40 depicted in FIG. 4 employs two elbow conduits 46, 48. The flow divider 92 has a lower cylindrical base portion 42 or region wherein the main flow of the industrial fluid enters said flow divider 92. The lower base portion or region 42 transitions to a diffusion region 44, having a geometry that is generally rectangular in design. As illustrated in FIG. 4, the diffusion section 44 includes two holes or ports that coincide with elbow conduits 46, 48 and allow for flow of industrial fluid there through.

[0053] In the orientation described in FIGS. 8 and 9, the steam distribution has been adapted such the central ducts 88, 90 have the same diameter. In the depicted orientation, the central ducts operate to feed steam to one street of one side of the central duct and half of the street on the other side of the central duct. Therefore, one central duct is feeding two modules each of the central duct and then alternating to one module each of side and so on and so forth.

[0054] Turning now to FIGS. 10 and 11, a quick connection design, generally designated 200, is illustrated. The quick connection includes a collar 210 and an internal sealing piece 212 that rests in, and is secured by the collar 210. The internal sealing piece 212 is generally circular in diameter and has a sealing component 214 such as an O-ring or the like, which provides sealing engagement between two conduits which will be discussed in further detail below. As illustrated in FIGS. 10 and 11, the collar 210 includes two halves or pieces 216, 218 connected via a swivel or hinge 220 at one end of the collar. The collar 210 also includes a sealing attachment of each side at the other end via an attachment mechanism 222. This attachment 222 is adjustable and in one embodiment, a nut and bolt combination is preferred.

[0055] Due to the fact that air cooled condenser typically operate under vacuum conditions, all connections obviously must be tight and secure. The most common way to provide a tight connection is welding the tubes or conduits together. The quick connection design is an alternative to welding. Accordingly, during operation, the collar 210 captures the flanges of two conduits 224, 226 wherein the sealing component functions to encircle the ends of each respective conduit. The collar 210 is then tightened around said sealing component via the adjustable attachment 222, sealing the conduits together. Quick connection can be employed on air cooled condensers in several connection applications for example condensate lines, air take off lines, and steam lines. Quick connections can be installed by less skilled personnel than required for welding which is very important especially when skilled personnel is in short supply.

[0056] During operation, typically, turbine back pressure of the air cooled condenser or the like is limited by the maximum steam velocity in the tubes (to limit erosion) wherein the steam velocity is increasing with a decrease of back pressure (due to density of steam). Thus, due to the addition of tubes as described in the present invention in combination with the flow divider design, the steam is still maintained at the maximum allowable steam velocity but at a lower back pressure. Another limitation the current delta design addresses is that the pressure at the exit of the secondary bundles cannot be less

than the vacuum pump capability. This pressure typically results from turbine back pressure minus the pressure drop in ducting minus the pressure drop in the tubes. Accordingly, due to the reduced pressure drop in the tubes, the allowable turbine back pressure is lower with the propose air cooled condenser design.

[0057] Furthermore, the above-described bundle design also reduces the pressure drop within the individual delta **12**, **14**. For example, the heat exchange that takes place via the deltas **12**, **14**, is dependent upon the heat exchange coefficient, i.e., the mean temperature difference between air and steam and the exchange surface. Due to the reduced pressure drop as previously described, the mean pressure (average between inlet pressure and exit pressure) in the exchanger is higher with the design of the proposed air cooled condenser. In other words, because steam is saturated, the mean steam temperature is also higher for the same heat exchange surface resulting in increased heat exchange.

[0058] Alternatively, the above described embodiments of the present employ tube bundles manufactured and assembled, prior to shipping, having steam manifold and steam condensate headers, alternative embodiment bundles may not include a manifold prior to shipping. More specifically, in such embodiments, the tube bundles may be ship without steam manifolds attached thereto. In said embodiments, the tube bundles may be assembled in field to form the A-type configuration, as discussed above. However, instead of employing two steam manifolds, this alternative embodiment may employ a single steam manifold wherein the single steam manifold extends along the “apex” of the A configuration.

[0059] Turning now to FIGS. **12** and **13**, a tee piece or flow divider **300** is illustrated in accordance with an alternative embodiment of the present invention. As illustrated in FIGS. **10** and **11**, the flow divider **300** has a main cylindrical portion or base **302** that provides a flow inlet. The flow divider **300** also comprises first and second flow branches each connected to, and extending from, the main cylindrical portion **302**. The flow branches **304**, **306** as illustrated have a geometry similar to truncated cone regions, **304** and **306** respectively, having a first region having a first diameter that transitions to a second region having a smaller diameter. As can be seen in FIGS. **10** and **11**, the flow branch portions **304**, **306** may alternatively be described as a melding or combination or merger of flow regions having a “T” geometry and a “Y” geometry. Also as illustrated in FIGS. **10** and **11**, the flow divider **300** includes cylindrical portions, **308** and **310**, attached to a respective branch **304**, **306**. Said cylindrical portions **308**, **310** have a diameter that is less than the diameter of the inlet portion **302**.

[0060] The above-described design requires less manufacture time, while also providing a lighter design allowing for less fluid side pressure drop. This present solution should also be more easily cut in piece and re-welded on site. Therefore, the current piece should be easily manufactured as it is constructed from simple pieces. Moreover, the above-described divider **200** design minimizes steam side pressure drops during operation of an air cooled condenser or the like.

[0061] As clearly illustrated in Table 1 below, three flow divider or duct riser connections: Design A, Design B and Design C. Design A is a standard “T” shape design currently used in the art whereas Design B is another “T” shaped design that utilizes flow vanes whereas Design C is the flow divider **300** of the present invention. As illustrated in the Table 1, Design C, or the flow divider **300** providing significant

improvement steam side pressure drop wherein it demonstrated **33** percent relative to the pressure loss coefficient, K for Design A. For Design B, demonstrated 90 percent relative to the pressure loss coefficient, K for Design A.

TABLE 1

References Conditions	Flow Divider Connection		
	Design A	Design B	Design C
K	—	0.730	0.239
Relative	%	100%	33%

[0062] The many features and advantages of the invention are apparent from the detailed specification, and, thus, it is intended by the appended claims to cover all such features and advantages of the invention which fall within the true spirit and scope of the invention. Further, since numerous modifications and variations will readily occur to those skilled in the art, it is not desired to limit the invention to the exact construction and operation illustrated and described, for example a forced draft air cooled condenser has been illustrated but an induced draft design can be adapted to gain the same benefits and, accordingly, all suitable modifications and equivalents may be resorted to that fall within the scope of the invention.

1. A flow divider for the distribution of a flow of industrial fluid for use in an air cooled condenser or the like having a vertical axis, the flow divider comprising:

- a cylindrical lower base portion that receives the flow of industrial fluid;
- an upper diffusion region that extends from said cylindrical base portion wherein said upper diffusion region is generally non-cylindrical in geometry;
- a first port disposed on said upper diffusion region that allows for the flow of industrial fluid there through; and a first conduit connected to said first port.

2. The flow divider according to claim 1, further comprising:

- a second port disposed on said upper diffusion region that allows for the flow of industrial fluid there through; and a second conduit connected to said second port.

3. The flow divider according to claim 2, further comprising:

- a third port disposed on said upper diffusion region that allows for the flow of industrial fluid there through; and a third conduit connected to said third port.

4. The flow divider according to claim 3, further comprising:

- a fourth port disposed on said upper diffusion region that allows for the flow of industrial fluid there through; and a fourth conduit connected to said fourth port.

5. The flow divider according to claim 1, wherein said upper diffusion region is generally square in geometry.

6. The flow divider according to claim 1, wherein said first conduit is an elbow conduit.

7. The flow divider according to claim 2, wherein said second conduit is an elbow conduit.

8. The flow divider according to claim 1, further comprising a flow vane disposed within said cylindrical lower base portion.

9. The flow divider according to claim 8, said flow vane is a plurality of flow vanes.

**10.** The flow divider according to claim **4**, wherein said first conduit is rotated about the vertical axis to a first position; wherein said second conduit is rotated about the vertical axis to a second position; wherein said third conduit is rotated about the vertical axis to a third position; and, wherein said fourth conduit is rotated about the vertical axis to a fourth position.

**11.** An air cooled condenser for cooling an industrial fluid, comprising:

a first condenser bundle having a first set of tubes having first and second ends;

a steam manifold connected to the first ends of the first set tubes;

a condensate header connected to said second end of the first set tubes;

a second condenser bundle having a second set of tubes having third and fourth ends;

a steam manifold connected to the third ends of the second set tubes;

a condensate header connected to said fourth end of the second set tubes;

a flow divider for the distribution of a flow of industrial fluid comprising:

a cylindrical lower base portion that receives the flow of industrial fluid;

an upper diffusion region that extends from said cylindrical base portion wherein said upper diffusion region is generally non-cylindrical in geometry;

a first port disposed on said upper diffusion region that allows for the flow of industrial fluid there through;

a second port disposed on said upper diffusion region that allows for the flow of industrial fluid there through;

a first conduit connected to said first port and said first set of tubes; and

a second conduit connected to said second port and said first set of tubes.

**12.** The air cooled condenser according to claim **11**, wherein said upper diffusion region is generally square in geometry.

**13.** The air cooled condenser according to claim **11**, wherein said first conduit is an elbow conduit.

**14.** The air cooled condenser according to claim **11**, wherein said second conduit is an elbow conduit.

**15.** The air cooled condenser according to claim **11**, further comprising a flow vane disposed within said cylindrical lower base portion.

**16.** The air cooled condenser according to claim **15**, said flow vane is a plurality of flow vanes.

**17.** A method for distributing a fluid to be cooled using a flow divider, comprising:

receiving the fluid to be cooled through a cylindrical lower base portion;

flowing the fluid to be cooled through an upper diffusion region that extends from said cylindrical base portion wherein said upper diffusion region is generally non-cylindrical in geometry;

flowing the fluid to be cooled through a first port disposed on said upper diffusion region; and

flowing the fluid to be cooled through a first conduit connected to said first port.

**18.** The method according to claim **17**, further comprising the step of flowing the fluid to be cooled through a second port disposed on said upper diffusion region.

**19.** The method according to claim **17**, wherein the upper diffusion region is generally square in geometry.

**20.** A flow divider for use with an air cooled condenser or the like, comprising:

means for receiving the fluid to be cooled through a cylindrical lower base portion;

means for flowing the fluid to be cooled through an upper diffusion region that extends from said cylindrical base portion wherein said upper diffusion region is generally non-cylindrical in geometry;

means for flowing the fluid to be cooled through a first port disposed on said upper diffusion region; and

means for flowing the fluid to be cooled through a first conduit connected to said first port.

\* \* \* \* \*