

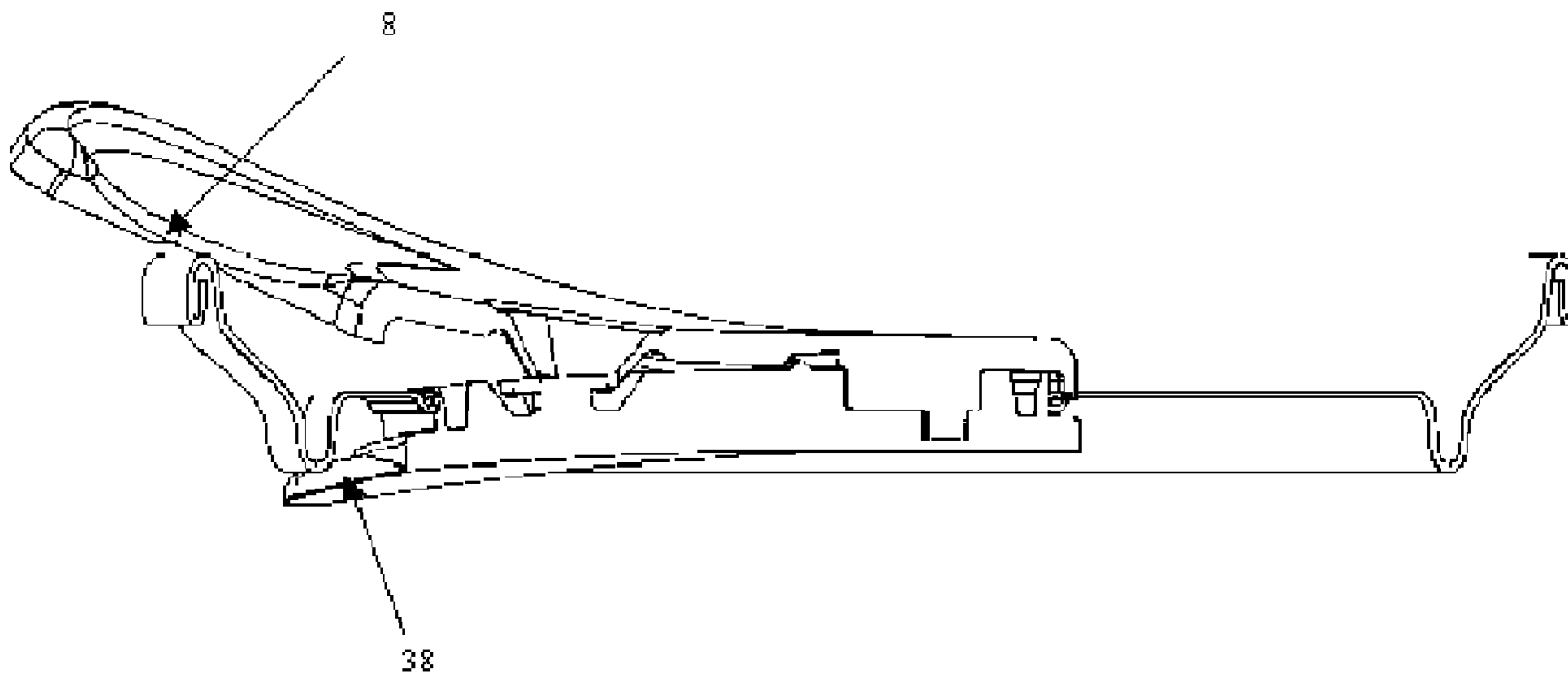

(86) Date de dépôt PCT/PCT Filing Date: 2007/05/08  
 (87) Date publication PCT/PCT Publication Date: 2007/11/15  
 (85) Entrée phase nationale/National Entry: 2008/11/07  
 (86) N° demande PCT/PCT Application No.: EP 2007/054420  
 (87) N° publication PCT/PCT Publication No.: 2007/128810  
 (30) Priorité/Priority: 2006/05/10 (EP06113767.5)

(51) Cl.Int./Int.Cl. *B65D 17/50* (2006.01)  
 (71) Demandeur/Applicant:  
 CROWN PACKAGING TECHNOLOGY, INC., US  
 (72) Inventeurs/Inventors:  
 PARIS, ALEXANDRE, GB;  
 RAMSEY, CHRISTOPHER PAUL, GB;  
 LE FEUVRE, MARK JAMES, GB  
 (74) Agent: FETHERSTONHAUGH & CO.

(54) Titre : DISPOSITIF D'OUVERTURE DE CANETTE  
 (54) Title: CAN OPENING DEVICE



(57) **Abrégé/Abstract:**

An opening device of plastics material, which is suitable for closing and re-closing of a metal can end, for example. The opening device has two distinct parts: a base plate (10) and a tab (1), which are joined together by an integral rivet (14, 15). The opening device is used to close an aperture in the metal panel of a can end by fitting the base plate to the underside of the panel and connecting this to the tab on the top of the panel. A sliding action by pulling or retaining the tab actuates movement of the base plate for opening and reclosing of the closure panel.

## (12) INTERNATIONAL APPLICATION PUBLISHED UNDER THE PATENT COOPERATION TREATY (PCT)

(19) World Intellectual Property Organization  
International Bureau



(43) International Publication Date  
15 November 2007 (15.11.2007)

PCT

(10) International Publication Number  
**WO 2007/128810 A1**

(51) International Patent Classification:  
*B65D 17/50* (2006.01)

(74) Agent: RATLIFF, Ismay; Downsview Road, Wantage,  
Oxfordshire OX12 9BP (GB).

(21) International Application Number:  
PCT/EP2007/054420

(81) Designated States (*unless otherwise indicated, for every kind of national protection available*): AE, AG, AL, AM, AT, AU, AZ, BA, BB, BG, BH, BR, BW, BY, BZ, CA, CH, CN, CO, CR, CU, CZ, DE, DK, DM, DZ, EC, EE, EG, ES, FI, GB, GD, GE, GH, GM, GT, HN, HR, HU, ID, IL, IN, IS, JP, KE, KG, KM, KN, KP, KR, KZ, LA, LC, LK, LR, LS, LT, LU, LY, MA, MD, MG, MK, MN, MW, MX, MY, MZ, NA, NG, NI, NO, NZ, OM, PG, PH, PL, PT, RO, RS, RU, SC, SD, SE, SG, SK, SL, SM, SV, SY, TJ, TM, TN, TR, TT, TZ, UA, UG, US, UZ, VC, VN, ZA, ZM, ZW.

(22) International Filing Date: 8 May 2007 (08.05.2007)

(25) Filing Language: English

(26) Publication Language: English

(30) Priority Data:  
06113767.5 10 May 2006 (10.05.2006) EP

(84) Designated States (*unless otherwise indicated, for every kind of regional protection available*): ARIPO (BW, GH, GM, KE, LS, MW, MZ, NA, SD, SL, SZ, TZ, UG, ZM, ZW), Eurasian (AM, AZ, BY, KG, KZ, MD, RU, TJ, TM), European (AT, BE, BG, CH, CY, CZ, DE, DK, EE, ES, FI, FR, GB, GR, HU, IE, IS, IT, LT, LU, LV, MC, MT, NL, PL, PT, RO, SE, SI, SK, TR), OAPI (BF, BJ, CF, CG, CI, CM, GA, GN, GQ, GW, ML, MR, NE, SN, TD, TG).

(71) Applicants (*for all designated States except US*):  
**CROWN PACKAGING TECHNOLOGY, INC** [US/US]; 11535 S. Central Avenue, Alsip, Illinois 60803-2599 (US). **CROWN PACKAGING UK PLC** [GB/GB]; Downsview Road, Wantage, Oxfordshire OX12 9BP (GB).

(72) Inventors; and

(75) Inventors/Applicants (*for US only*): **PARIS, Alexandre** [FR/GB]; 20 Woodley Close, Abingdon, Oxfordshire OX14 1YH (GB). **RAMSEY, Christopher, Paul** [GB/GB]; Braeside, Manor Road, Wantage, Oxfordshire OX12 8DP (GB). **LE FEUVRE, Mark, James** [GB/GB]; 12 Oxford Road, Littlemore, Oxford, Oxfordshire OX4 4PE (GB).

**Published:**

- with international search report
- before the expiration of the time limit for amending the claims and to be republished in the event of receipt of amendments

*For two-letter codes and other abbreviations, refer to the "Guidance Notes on Codes and Abbreviations" appearing at the beginning of each regular issue of the PCT Gazette.*

(54) Title: CAN OPENING DEVICE

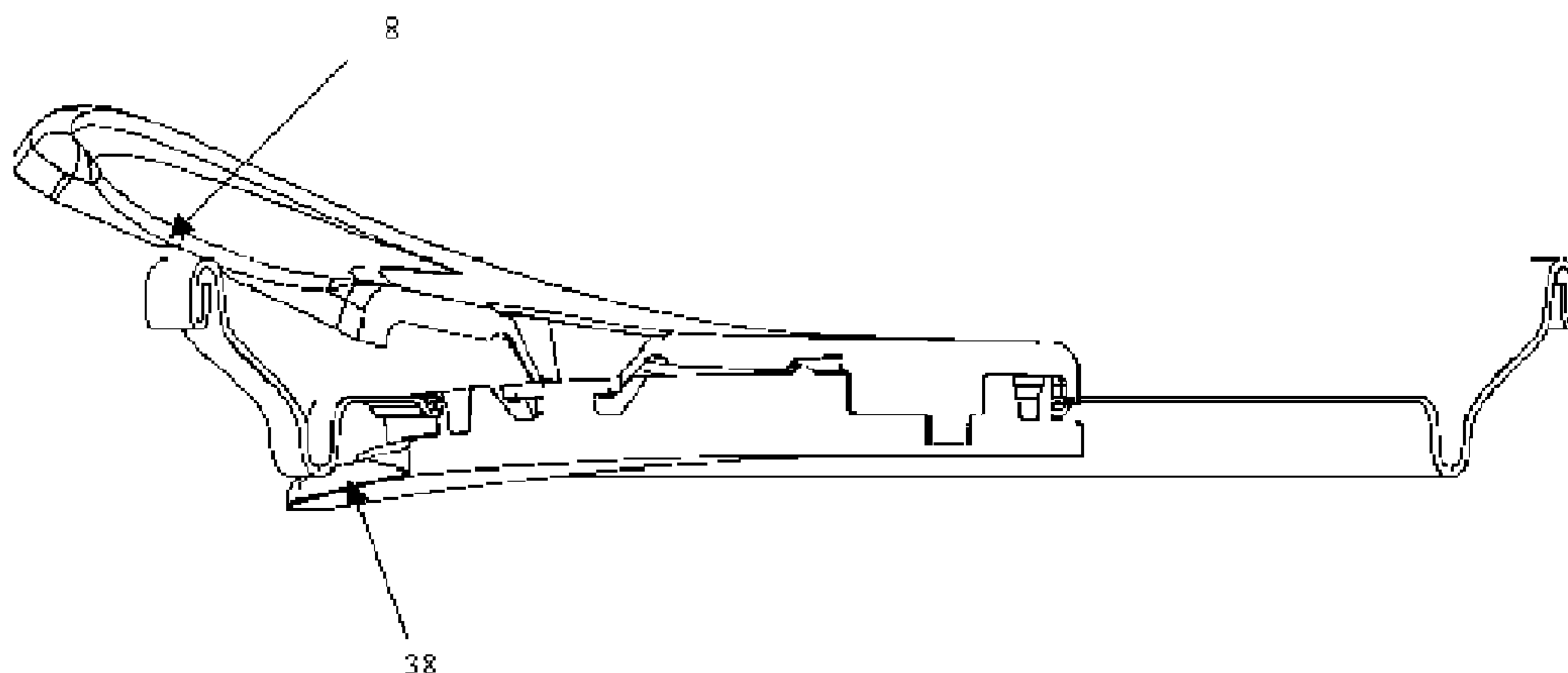

(57) Abstract: An opening device of plastics material, which is suitable for closing and re-closing of a metal can end, for example. The opening device has two distinct parts: a base plate (10) and a tab (1), which are joined together by an integral rivet (14, 15). The opening device is used to close an aperture in the metal panel of a can end by fitting the base plate to the underside of the panel and connecting this to the tab on the top of the panel. A sliding action by pulling or retaining the tab actuates movement of the base plate for opening and reclosing of the closure panel.

WO 2007/128810 A1

# Description

## CAN OPENING DEVICE

### Technical Field

[0001] This invention relates to an opening device. In particular, but not exclusively, it relates to an opening device for use with a metal closure such as a can end or bottle cap.

### Background Art

[0002]

Patent Citation 0001: US 4369888 --.

describes an opening device which forms the whole closure for a metal container. A neck part of the closure snaps around a locking shoulder on the container. A plug section is hinged to the neck part and is folded into the neck part to close the container. A vent hole in the plug section is closed by a lug on an integral ring pull, which is hinged to the plug at the opposite end to the plug-neck fulcrum.

[0003] The hinge between the ring pull and plug sections of the opening device of

Patent Citation 0002: US 4369888 --.

is relatively fragile and may become detached during opening or before removal of the plug can be initiated. Furthermore, the opposing hinges require a high pull force if the plug is to be removed simply by pulling on a ring pull which is attached to the plug at the opposite end to the plug-neck fulcrum. In addition, the device requires special features on the can neck opening to which the closure neck part is directly fixed. The metal of the can body is very thin and the shoulder formed on the can body neck is subject to significant forces when the closure is opened which may deform the shoulder and compromise any seal for recloseability or risk the entire closure being removed from the container.

[0004] Continental Can's patent no.

Patent Citation 0003: FR 1434827 --.

describes a metal can end having a plastics opening device which has a tubular part in an opening of the can end. A tear strip is defined by a score between the tear strip and the tubular part, on the underside of the opening device and inside the container to which the device is attached. The tubular part is said to provide a bore seal with the can end opening and a peripheral edge on the tubular part opposes movement of the tubular part out of the can end opening. However, whilst this patent states that the opening device is easy to open, there is clearly a major risk of accidental opening due

to premature tearing of the score or distortion of the plastics opening device when the container is dropped or mishandled in any way. Similarly, if the container is used for carbonated beverages, which are transported or maintained in high ambient temperatures, the soft plastic may deform or creep, leading to product leakage. Most importantly for the context of the present invention, once the opening device of Patent Citation 0004: FR 1434827 --.

has been opened and the score broken, the device is not capable of reclosing to prevent spillage and maintain residual carbonation.

[0005] This invention seeks to provide an opening device which is capable of reclosing a container, which requires reduced opening force in comparison with the prior art and is easy to manufacture, assemble and operate. Furthermore, the opening device of the invention is adapted to use for packaging carbonated beverages and for use in hot countries. The opening device, whilst being easy to open and reclose, is configured so that creep of the plastic will tend to improve rather than compromise the sealing characteristics.

### **Disclosure of Invention**

[0006] According to the present invention there is provided an opening device which comprises: a base plate and a tab which comprises a nose, and a handle at its distal end; in which the opening device is adapted, in use, to close an aperture in a metal closure panel, with the base plate on one side of the panel and the tab on the opposite side; and in which the base plate and/or tab further includes a wall which extends perpendicularly from the plate or tab respectively and provides an interference or friction fit with the edge of the aperture so as to seal around the perimeter of the closure aperture; characterised in that, when the opening device is used in combination with a metal closure having a metal closure panel, actuation of the tab translates into movement of the base plate, and the closure panel and opening device include complementary features for moving the opening device relative to the closure panel for opening or reclosing.

[0007] The can end of prior art Patent Citation 0005: FR 1434827 --. is not recloseable and cannot maintain carbonation after initial opening. The opening device and can end panel of the prior art do not include complementary features which are able to co-operate for opening without preventing reclosing the closure panel. The complementary features of the opening device of the present invention preferably comprise a cam profile on the closure panel and a cam follower on the base plate. Al-

ternatively, the complementary features may comprise one or more rails on the closure panel and one or more grooves on the base plate, or *vice versa*. When the closure panel is a beverage can end, the cam profile may be provided by the underside of a circumferential bead such as a countersink adjacent chuck wall and seam.

[0008] In a preferred embodiment of the invention, the base plate includes a flange for cooperating with the underside face of the closure panel and providing sealing. The face seal is energised when the closure is in its closed position as pressure from product within the container builds up and may be reactivated when reclosed. The flange is particularly useful at elevated internal can pressure when the seal between the base plate wall and the aperture provides force to energise this face seal.

[0009] Ideally, the base plate includes a button which extends perpendicularly away from the base plate, and the tab includes a rivet hole, such that the tab is fixed to the base plate with the base plate on one side of the panel and the tab on the opposite side, by staking the button in the rivet hole to form a rivet. Alternative fixing features may be provided to connect the base plate and tab together.

[0010] In one embodiment, the tab includes a lug, which is adapted to extend through a complementary vent hole in the base plate or closure panel. This enables venting of can contents, prior to releasing of the primary seal between the base plate wall and aperture of the closure panel.

[0011] The tab may include one or more hinges for venting and/or re-closing. In one embodiment, the tab is hinged at its front, middle and sides so that during opening the back edge of the base plate moves downwardly away from the closure panel to vent, and during re-closing the back edge is levered up to re-engage the bore seal.

[0012] The combination of a metal closure and this opening device may use a tab profile which has a feature for functioning as a cam follower and a complementary feature on the closure which functions as a cam, or *vice versa*. For example, the closure may be a can end having a chuck wall which functions as the cam.

[0013] The opening device may be made as a single component, with the tab being inserted through the aperture and the base plate wall creating a bore seal. Alternatively, the base plate and tab may be separate components.

[0014] According to a further aspect of the present invention, there is provided a method of forming the closure and opening device combination, the method comprising: providing a one piece opening device having a tab part and a base plate part, inserting the tab part of the opening device through an aperture in the closure panel and engaging the edge of the aperture with the wall of the base plate so that the base plate

is seated on the underside of the closure panel and the tab component above the panel. This method may include the steps of orienting the base plate on the underside of the closure aperture and the tab component above the aperture; inserting a button of the opening device through the rivet hole of the tab component, thereby trapping the closure panel therebetween;

crushing and staking the button to form a rivet and fix the opening device onto the closure.

[0015] The orienting step may be achieved by inserting a flexible wall of the base plate through the closure aperture and thereby sealing the aperture. Additional sealing is provided between a flange of the base plate which co-operates with the underside face of the closure panel.

[0016] The metal closure may be a can end, cap or other closure which is not normally re-closable.

### **Brief Description of the Drawings**

[0017] Preferred embodiments of the invention will now be described, by way of example only, with reference to the drawings, in which:

[0018] Figure 1 is a side section of a closure fitted with the opening device of the invention, in closed position;

[0019] Figure 2 is a like side section to that of figure 1, after breaking of a tab for tamper evidence;

[0020] Figure 3 is a like side section to that of figures 1 and 2, after venting of a container to which the closure is fitted;

[0021] Figure 4 is a like side section to that of figures 1 to 3, after release of the base plate;

[0022] Figure 5 is a like side section to that of figures 1 to 4, after opening;

[0023] Figures 6 to 8 are side views showing assembly of the opening device onto a can end;

[0024] Figure 9 is an underneath view of a can end with a cam profile; and

[0025] Figure 10 is a side section of the can end of figure 9;

[0026] Figure 11 is a side section of a closure fitted with a second embodiment of opening device of the invention, in closed position;

[0027] Figure 12 is an underneath view of the closure of figure 11;

[0028] Figure 13 is a perspective view of a can body fitted with the closure of figures 11 and 12;

[0029] Figure 14 is a side section of the closure of figure 11 during venting;

[0030] Figure 15 is an underneath view of the closure of figure 14;

[0031] Figure 16 is a perspective view of the closure of figures 14 and 15, fitted to a can body;

[0032] Figure 17 comprises different views of the can body and closure during opening;

[0033] Figure 18 is a schematic plan view showing opening movement of the opening device;

[0034] Figure 19 is a side view of the opening device in its open position; and

[0035] Figure 20 is a side view of the closure during reclosing of the opening device.

### **Mode for the Invention**

[0036] Figures 1 to 8 show an opening device according to a first embodiment of the invention, fitted to a metal can end 20. The opening device is of plastics material but this is not essential and one or more components of the device, such as the tab for example, could be of metal. The can end has a closure panel 21 in which an aperture has been formed and, in the embodiment shown, the edges of the aperture have been curled 22 so as to avoid exposure of cut edges of the metal. The opening device, which is of plastics material, comprises an upper part or top plate comprising tab 1, and a base plate 10 which provides a "top hat" seal with the aperture.

[0037] In figure 1, the opening device is shown in its closed position with tab 1 lying on an upper side of closure panel 21 of the can end. An optional pin 2 depends from tab 1 and is used as a retention device by engaging a vent hole 23 in the closure panel 21. This vent hole is optional depending on product within the can (i.e. internal pressure), properties such as thickness and flexibility of metal selected for the can end and ability to avoid metal exposure around the vent hole by curling etc. The tab has a primary hinge 3 and, in the embodiment of figures 1 to 8, a secondary hinge 4, the operation of which is set out in detail below.

[0038] The primary function of base plate 10 is to provide an axial face seal between its sealing plate 13 and the underside of closure panel 21. This face seal is triggered by the lateral bore seal between flexible wall 12, which is spaced slightly inwardly from the periphery of the sealing plate, and the curled edge 22 of the closure panel aperture. The base plate is fixed to the tab by a rivet 11, which is formed integrally with the base plate.

[0039] Figure 2 shows the opening device with tamper evident feature 5 hinged ("broken") away from the closure panel 21. In figure 3, venting of the container is possible via vent hole 23 when the tab 1 is raised further by hinging at primary hinge 3. Such venting releases the internal pressure in the can body and reduces forces which seat the sealing plate 13 against the underside of the closure panel.

- [0040] In order to open the can to which the end is fixed, the user presses down on the tab in the direction of the arrow (figure 4). This forces the base plate 10 away from the aperture into the disengaged position shown in figure 4 by hinging at secondary hinge 4. Pulling across the closure panel by the tab causes the closure to slide and thereby opens the can end exposing the pouring/dispensing aperture 25 as shown in figure 5.
- [0041] Reclosing of the can is achieved by carrying out the above steps in reverse. Firstly the entire opening device is slid until its base plate is directly underneath the aperture 25. Lowering tab 1 causes the base plate to move upwardly and re-engage the edge of aperture 25 for closing. Since the tamper evident feature 5 has already been broken, this will remain in the position of figure 2, thus showing that the container has been opened at least once.
- [0042] Steps for assembly of the recloseable can end can be seen from the assembly steps of figures 6 through 8. Figure 6 shows the relative positions of the separate components for orienting prior to assembly. In particular, the button 14 for forming rivet 11 is directly beneath profiled rivet hole 15 in the tab. Hole 15 has a lower cylindrical part, the diameter of which matches the button 14 and an upper part for staking the rivet.
- [0043] Pin 2 of the tab 1 is directly above vent hole aperture 23 in the closure panel 21 of can end 20. The curl 22 around pouring/dispensing aperture 25 can be clearly seen in figure 6, as can the partial curl around vent hole 23.
- [0044] In figure 7, the two parts of the opening device have been brought together and the button 14 inserted into rivet hole 15. Pin 2 engages vent hole 23. Finally, the rivet 11 is formed by staking, in which pressure applied in the direction of the arrow in figure 8 collapses the button 14 into the wider diameter part of rivet hole 15.
- [0045] The embodiment of figures 1 to 8 uses a sliding action to reciprocate between open and closed positions of the opening device. Clearly alternative reciprocating actions are also within the scope of the invention as defined by the claims. For example, in the embodiment of figures 9 and 10 the base plate 10 and closure panel 21 include complimentary cam features 28, 29 such that rotation of the base plate 10 moves cam follower 28 along the cam profile 29 of the closure panel resulting in opening of the aperture 25. Alternative cam features could operate by lateral sliding of the base plate.
- [0046] One alternative embodiment of cam opening can be seen from the embodiment shown in figures 11 to 21.
- [0047] Figure 11 is similar to figure 1 and shows the base, or sealing plate 10 under a can end closure panel 21. The base plate 10 is staked to the top plate 1 in order to form a



pair of rivets 11 in the same manner as described for figures 6 to 8. Rivet pair 11 forms a primary rivet, which fixes the tab (top plate) 1 to the sealing plate. As best seen in figure 13, rivet 11 may comprise more than one rivet, located around the centre of a chord. Alternatively, a single rivet at the centre of the chord, rivets at the ends of the chord or a single long connection between the base plate 10 and tab 1 is possible within the scope of the invention. Although rivets are preferred as a means of connection, other methods of fixing or bonding the base plate and tab together are possible within the scope of the invention.

[0048] In this embodiment, a second post on base plate 10 engages the top plate and is staked to form a tamper evident rivet 6. The tab 1 disengages from rivet 6 for opening, thereby providing tamper evidence. Aperture 7 includes a countersink in which the rivet head is disposed while the closure is in its fully closed position. The rivet head 6 is adapted to be pulled through the aperture when tab 1 is lifted for opening (see figure 14). The rivet 6 cannot then be re-inserted into the countersink after initial opening of the closure, even when the opening device is moved to reclose the pouring aperture. In this way tamper evidence is clear from the rivet 6 not being located in the countersink aperture 7.

[0049] Although not shown in the drawings, another type of tamper evidence could be provided by a thin web in the tab, with at least a part of the aperture 7 being formed in the web. The rivet would then be located in or above the web while the closure is in its fully closed position, and the web would be ruptured upon opening.

[0050] The can end 20 comprises closure panel 21 which extends into a circumferential countersink 31, chuck wall 32 and seaming panel 33. The seaming panel 33 is shown schematically in the figures in its fully curled position, as it would be when forming part of a double seam to join the closure to a can body. The reference numeral 33 is used for both the seaming panel and seam in the figures.

[0051] Referring now to figure 12, a cam follower 38 is formed by a "squared-off" portion of the base plate 10. Countersink 31 forms a cam profile so that rotation of the tab and base plate (fixed together by rivets 11) assists in progressive lowering of the base plate for venting gas pressure from within the container to which the closure is fixed. Venting and pouring is provided through a single hole.

[0052] Other features of the opening device/can end are used to form additional or alternative cam followers and cam profiles. For example as shown in figure 13, in which the can end 20 is shown seamed to a beverage can body, the tab has been provided with a profile which forms a cam follower 8 and the chuck wall angle provides a cam

profile 32. The chuck wall 31 of the figures is inclined at an angle of about 45°. The can end 20 used in this example is of the type described in Patent Citation 0006: EP 0828663 B --.

, which has a chuck wall angle of from 40° to 60°, although more upright, smaller angles are also possible within the scope of the invention. The shape of tab 1 in figure 13 suggests to the user that clockwise rotation is required to open the can.

[0053] Figures 14 to 16 show tamper evidence actuation and venting. As best shown in figure 14, the tab is disengaged from tamper evident rivet 6, the tab 1 is rotated and the cam follower 8 at the apex of tab 1 follows the chuck wall 32. Simultaneously, cam follower 38 on base plate 10 follows the countersink 31 and creates a path for venting. The under plan view of figure 15 shows both tab 1 and base plate 10 in their vent positions.

[0054] The cam follower 8 on tab 1 follows the chuck wall 32 onto seam 33 and the tab 1 thereby moves into the open position (figure 17). The movement of the centre point of the opening device during opening is denoted by the broad arrow in figure 18. By having the pouring aperture 25 close to the closure panel edge, cam action is assisted. The front rivets 11 follow the path 16 shown by the narrower 'spiral' line.

[0055] In order to maintain the opening device in its open position, a lug 17 on base plate 10 clips over the edge of dispensing aperture 25 as shown in figure 19. Lifting of the tab disengages this lug by tilting the base plate and the opening device may then be slid back into the aperture 24.

[0056] The opening device of the present invention is particularly adapted for reclosing by lifting the tab so that the base plate wall re-engages the interference fit with the edge 22 of the closure panel aperture. In particular, the base plate flange then contacts the underside of the closure panel to re-establish a face seal. This face seal is further assisted by residual carbonation of product in the re-closed can: by reclosing the opening device of the present invention to re-establish both bore and face seals, residual carbonation is maintained and allows pressure to build up to maintain the base plate in its closed position. Any remaining beverage in the re-closed container will not spill, even if the container is tipped over.

[0057] Cam profiles according to this invention may be formed by both the countersink and chuck wall/seam as in figures 11 to 21, discrete features as in figures 9 and 10, or by only a single cam on either the base plate side or the tab side of the closure.

[0058] Although the invention has been described above with reference to a metal can end, the opening device could be used to close and reclose other metal closures, such as a

bottle cap.

## Claims

- [0001] An opening device which comprises: a base plate (10) and a tab (1) which comprises a nose, and a handle at its distal end; in which the opening device is adapted, in use, to close an aperture in a metal closure panel (21), with the base plate (10) on one side of the panel (21) and the tab (1) on the opposite side; and in which the base plate and/or tab further includes a wall (12) which extends perpendicularly from the plate or tab respectively and provides an interference or friction fit with the edge of the aperture so as to seal around the perimeter of the closure aperture;
- characterised in that, when the opening device is used in combination with a metal closure having a metal closure panel, actuation of the tab (1) translates into movement of the base plate (10), and
- the closure panel and opening device include complementary features for moving the opening device relative to the closure panel for opening and/or reclosing.
- [0002] An opening device according to claim 1, in which the complementary features comprise a first cam profile (29) on the closure panel and a first cam follower (28) on the base plate.
- [0003] An opening device according to claim 1, in which the complementary features comprise one or more rails on the closure panel and one or more grooves on the base plate, or *vice versa*.
- [0004] An opening device according to any one of claims 1 to 3, in which the base plate includes a flange for co-operating with the underside face of the closure panel and providing sealing, the seal being adapted to be energised when internal pressure builds up when the closure is in its closed position.
- [0005] An opening device according to claim 4, in which the seal is adapted to be re-activated when the closure is reclosed.
- [0006] An opening device according to any one of claims 1 to 5, in which the base plate (10) includes a button (14) which extends perpendicularly away from the base plate (10), and the tab (1) includes a rivet hole (15), such that the tab is fixed to the base plate with the base plate (10) on one side of the panel (21) and the tab (1) on the opposite side, by staking the button (14) in the rivet hole (15) to form a rivet (11).
- [0007] An opening device according to any one of claims 1 to 6, in which the tab

includes a lug which is adapted to extend through a complementary vent hole in the base plate or closure panel.

[0008] An opening device according to any one of claims 1 to 7, in which the tab includes one or more hinges for venting and/or re-closing.

[0009] The combination of a metal closure and the opening device of any one of claims 1 to 8.

[0010] The combination of claim 9, further comprising a tab profile which has a feature for functioning as a second cam follower and a complementary feature on the closure which functions as a second cam, or *vice versa*.

[0011] The combination of claim 10, in which the closure is a can end having a chuck wall which functions as the second cam.

[Fig. 0001]

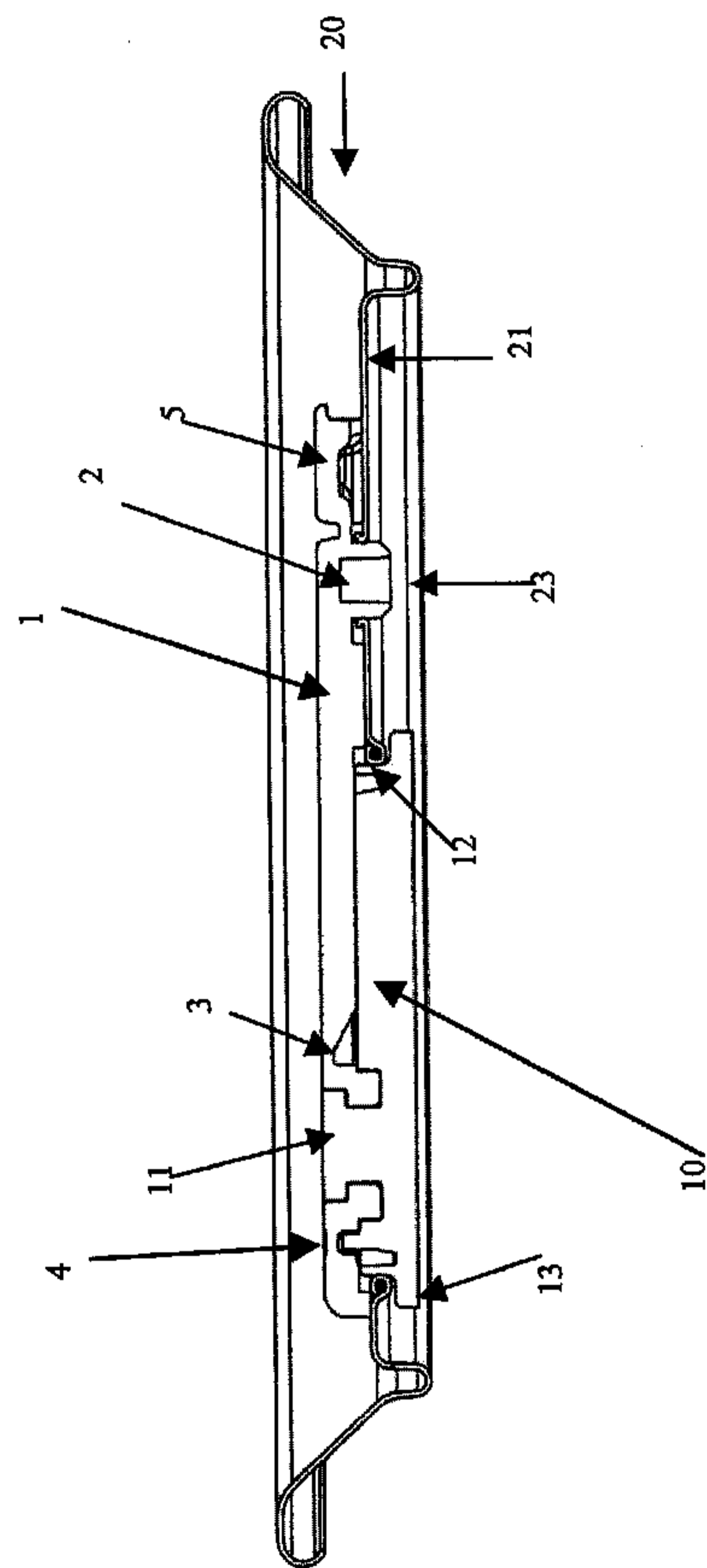

[Fig. 0002]

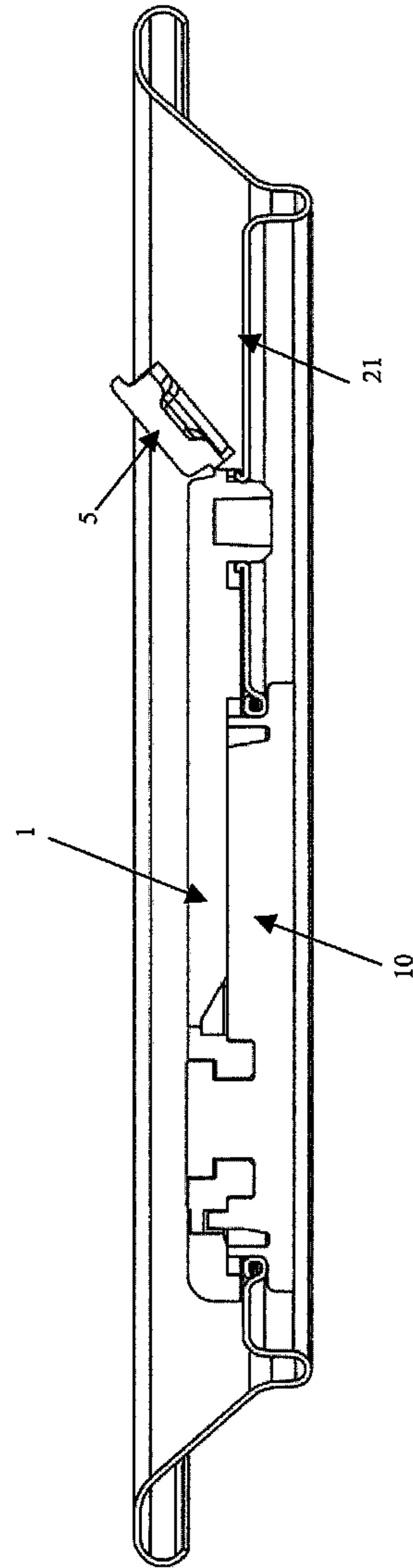

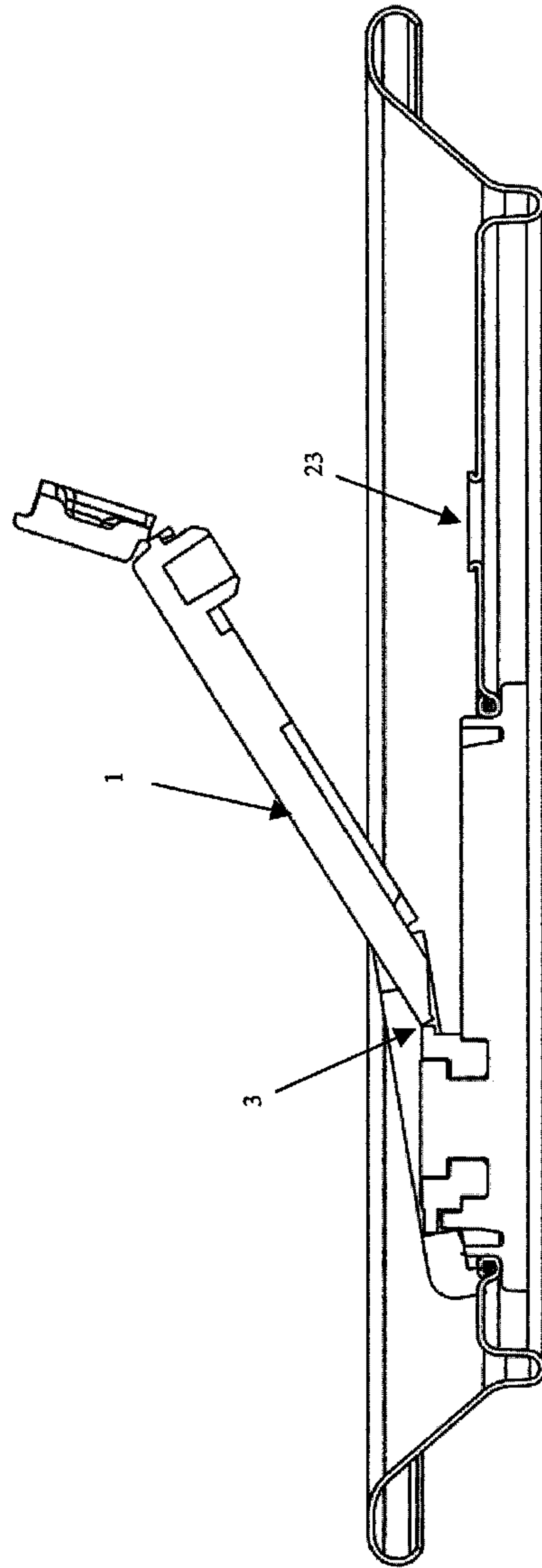



[Fig. 0004]

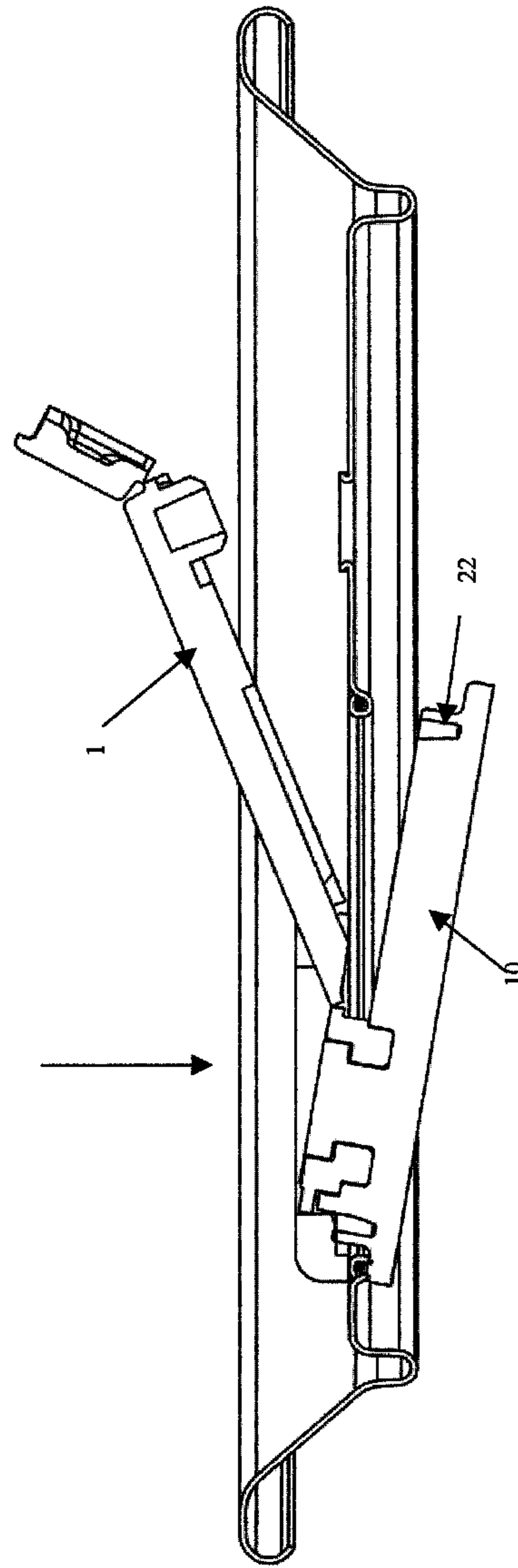

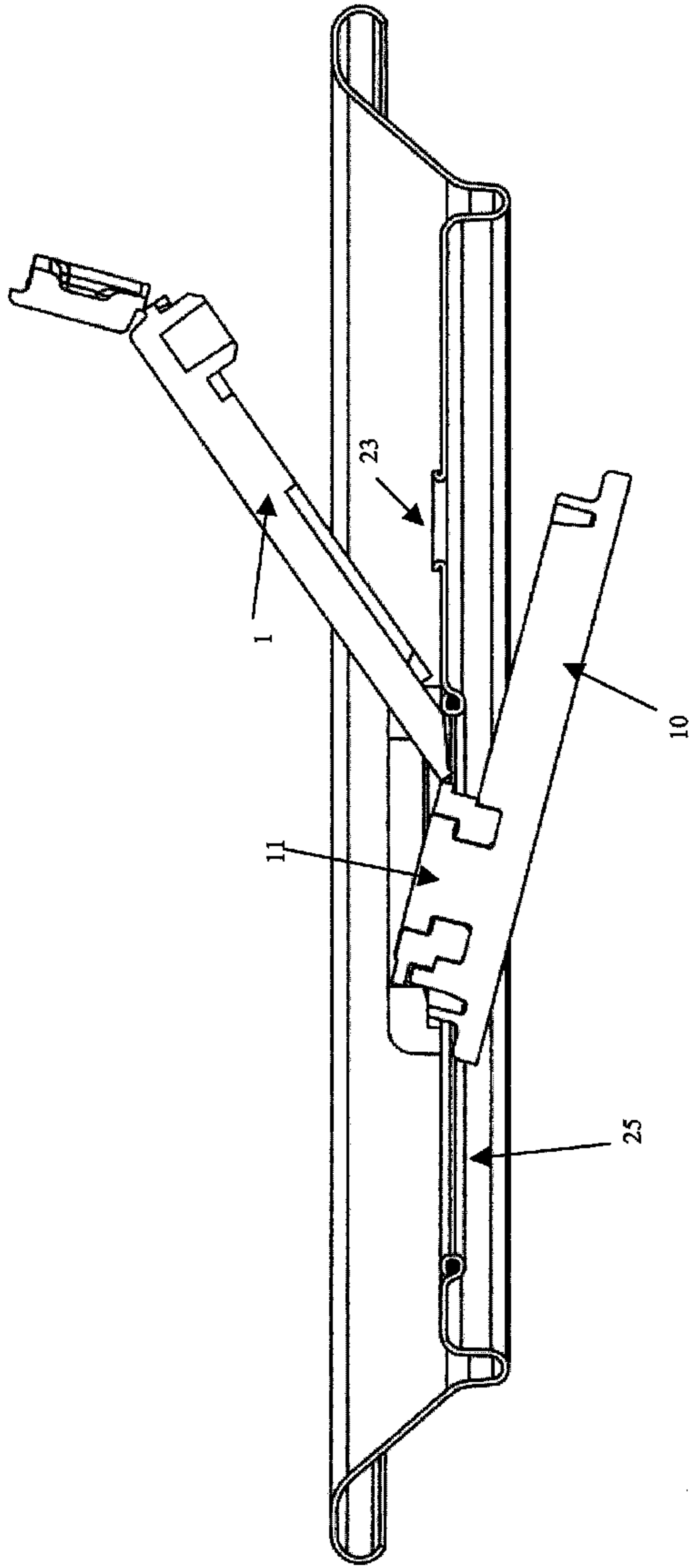

[Fig. 0006]

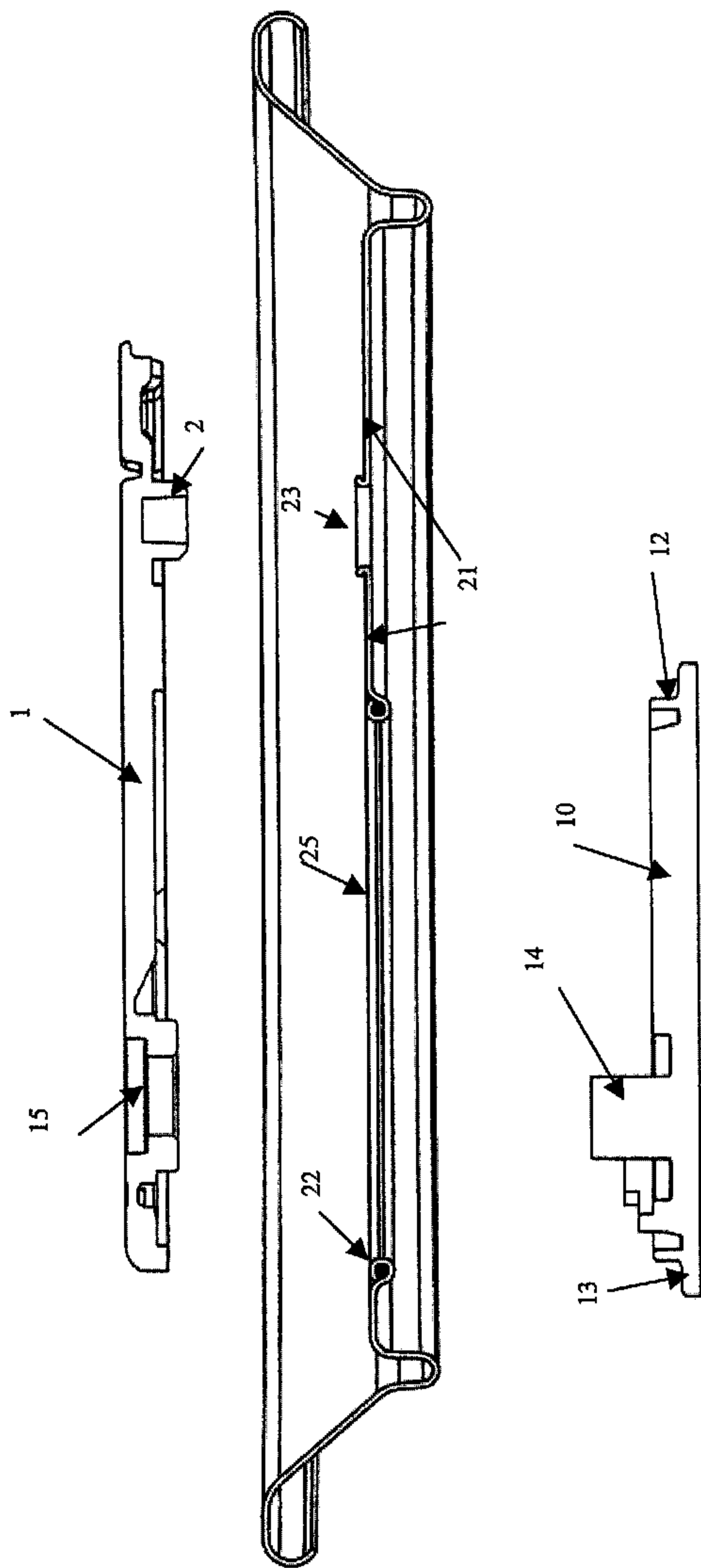

[Fig. 0007]

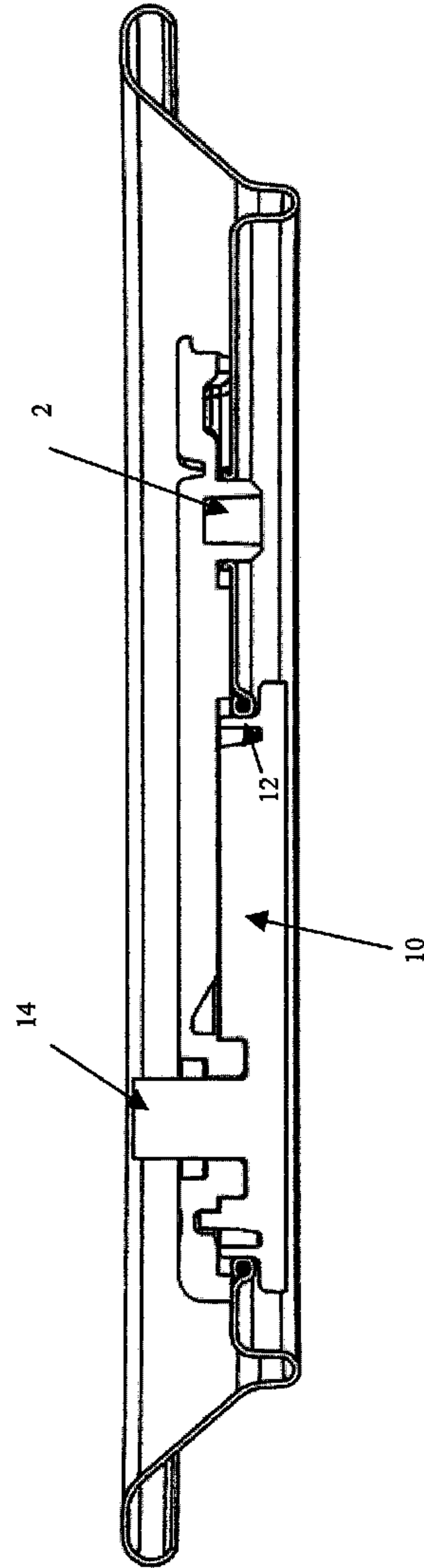

[Fig. 0008]

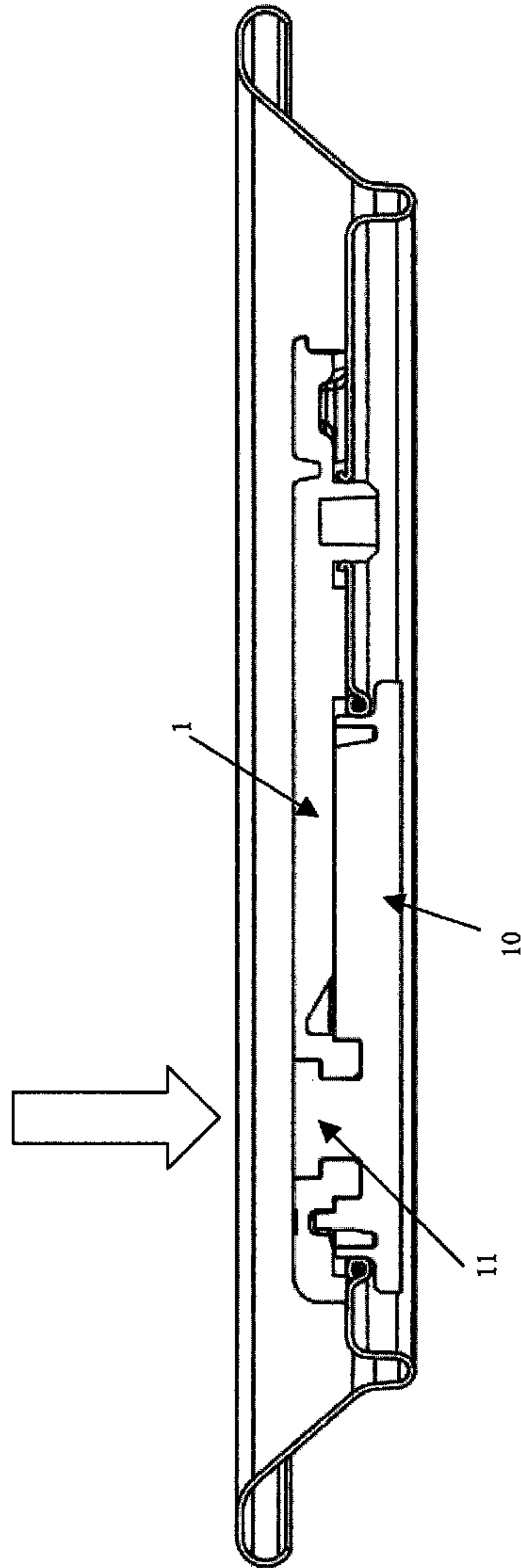

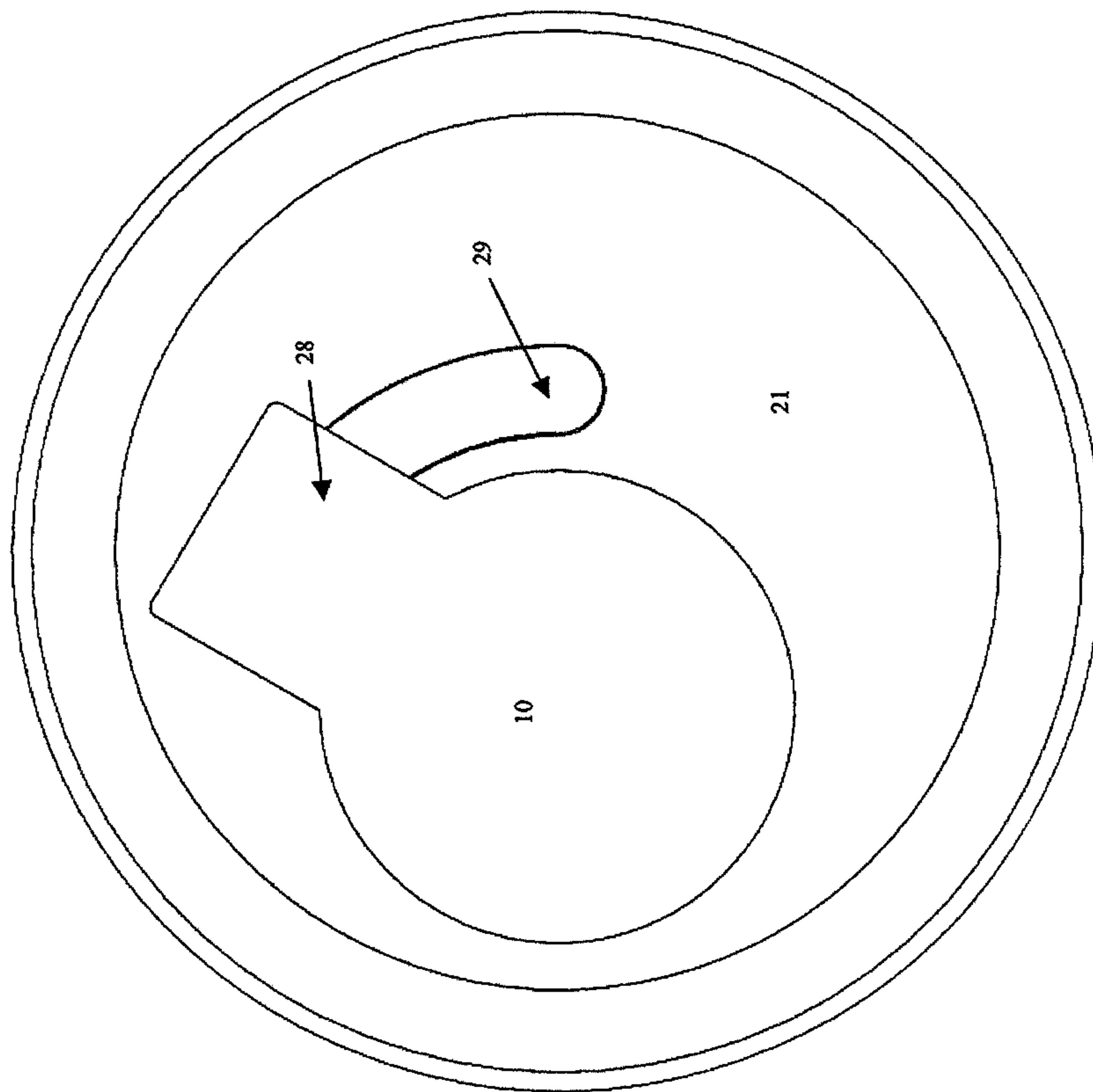

[Fig. 0010]

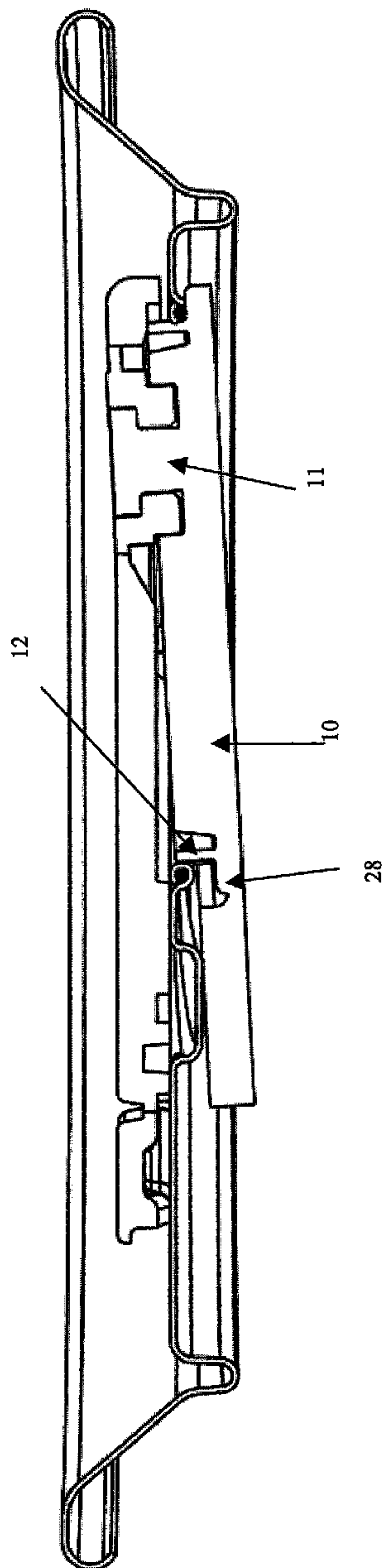

[Fig. 0011]

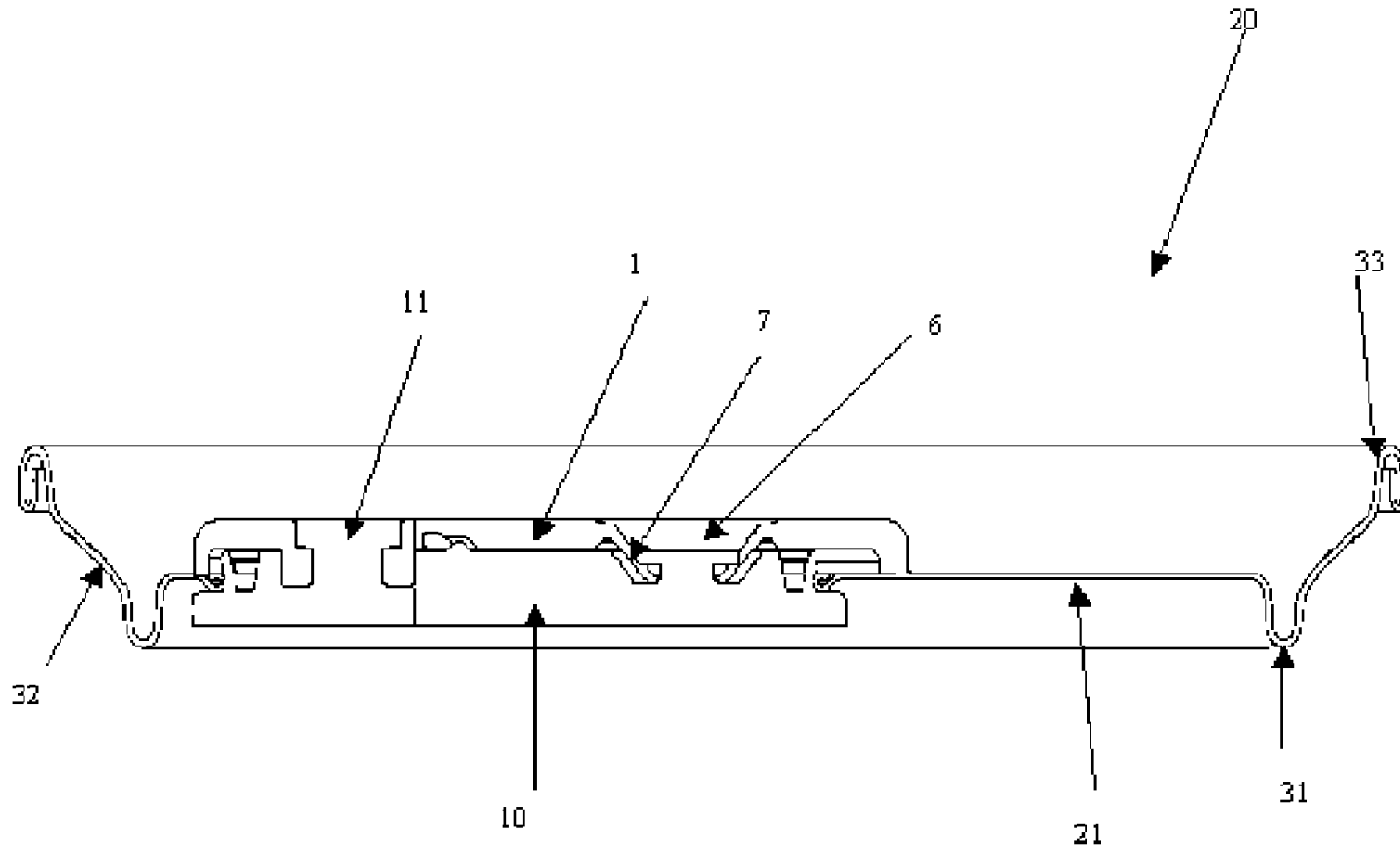



[Fig. 0012]

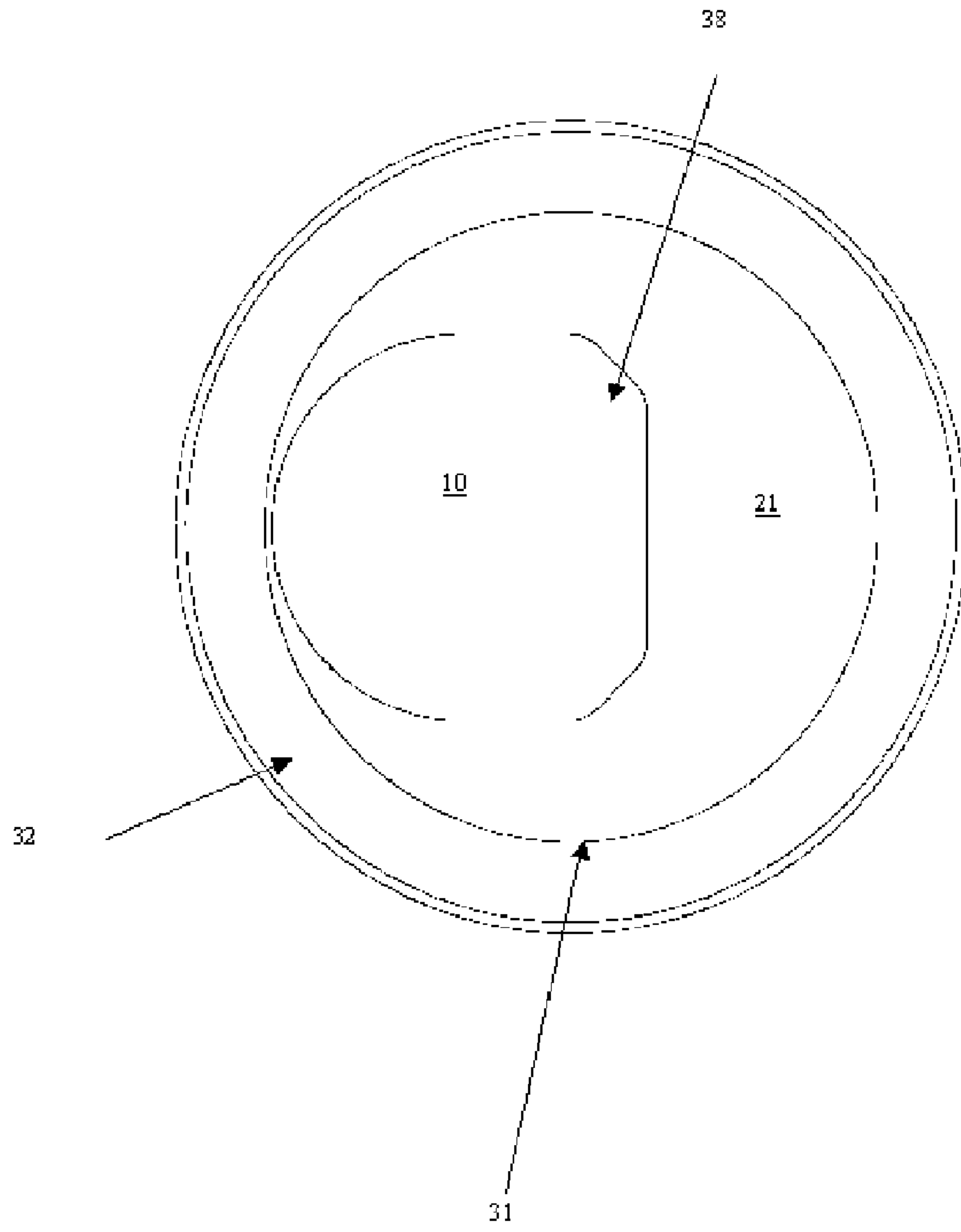

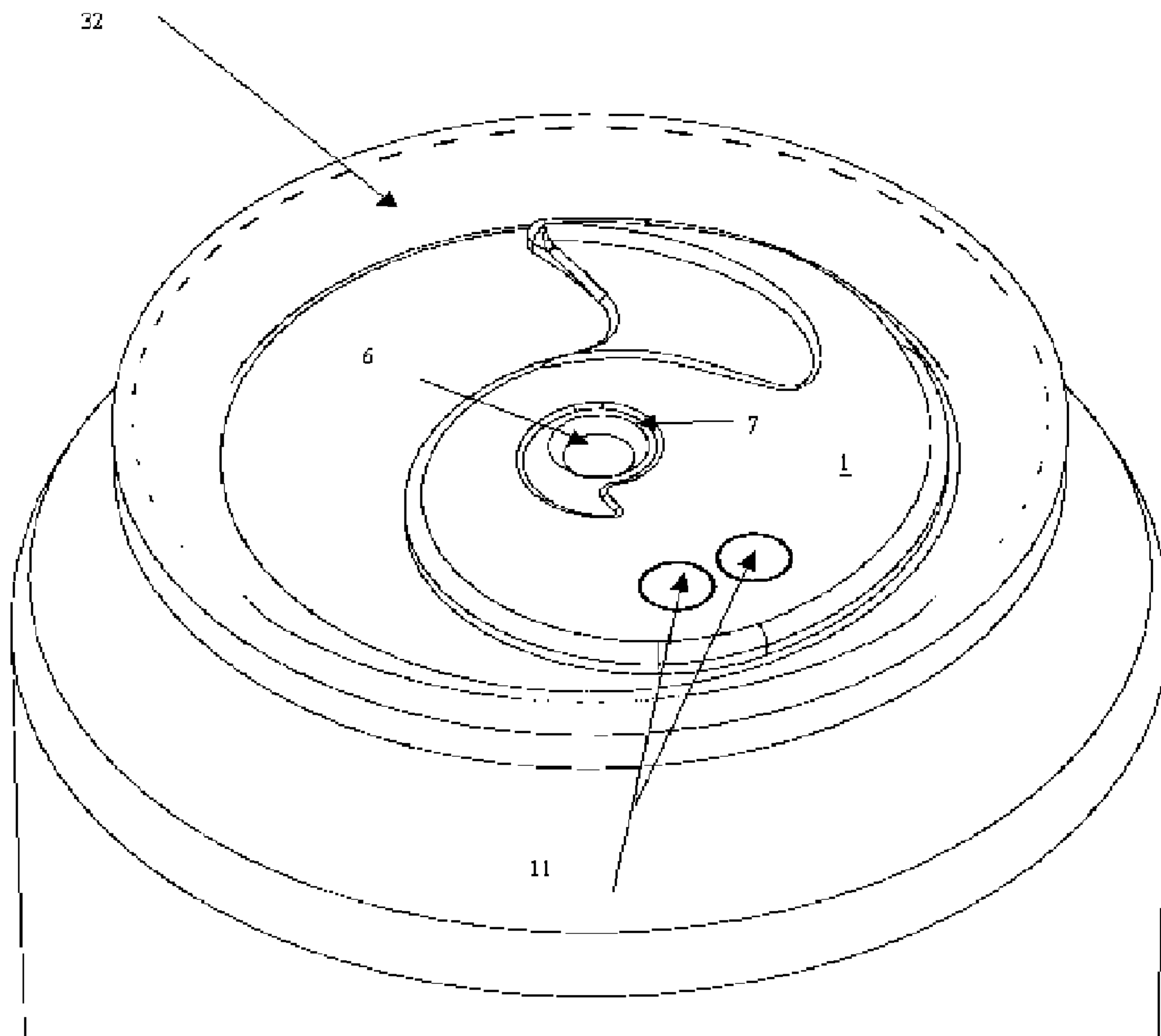

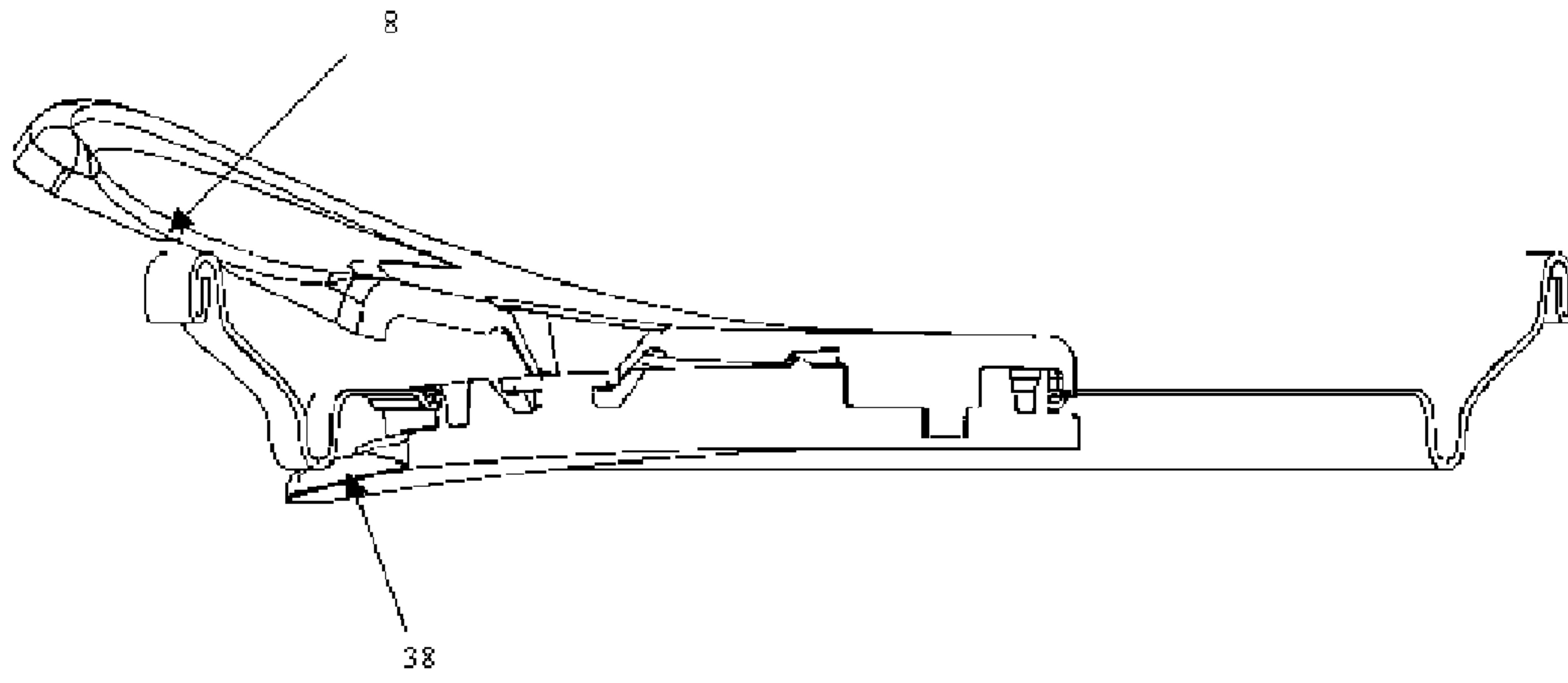

[Fig. 0015]

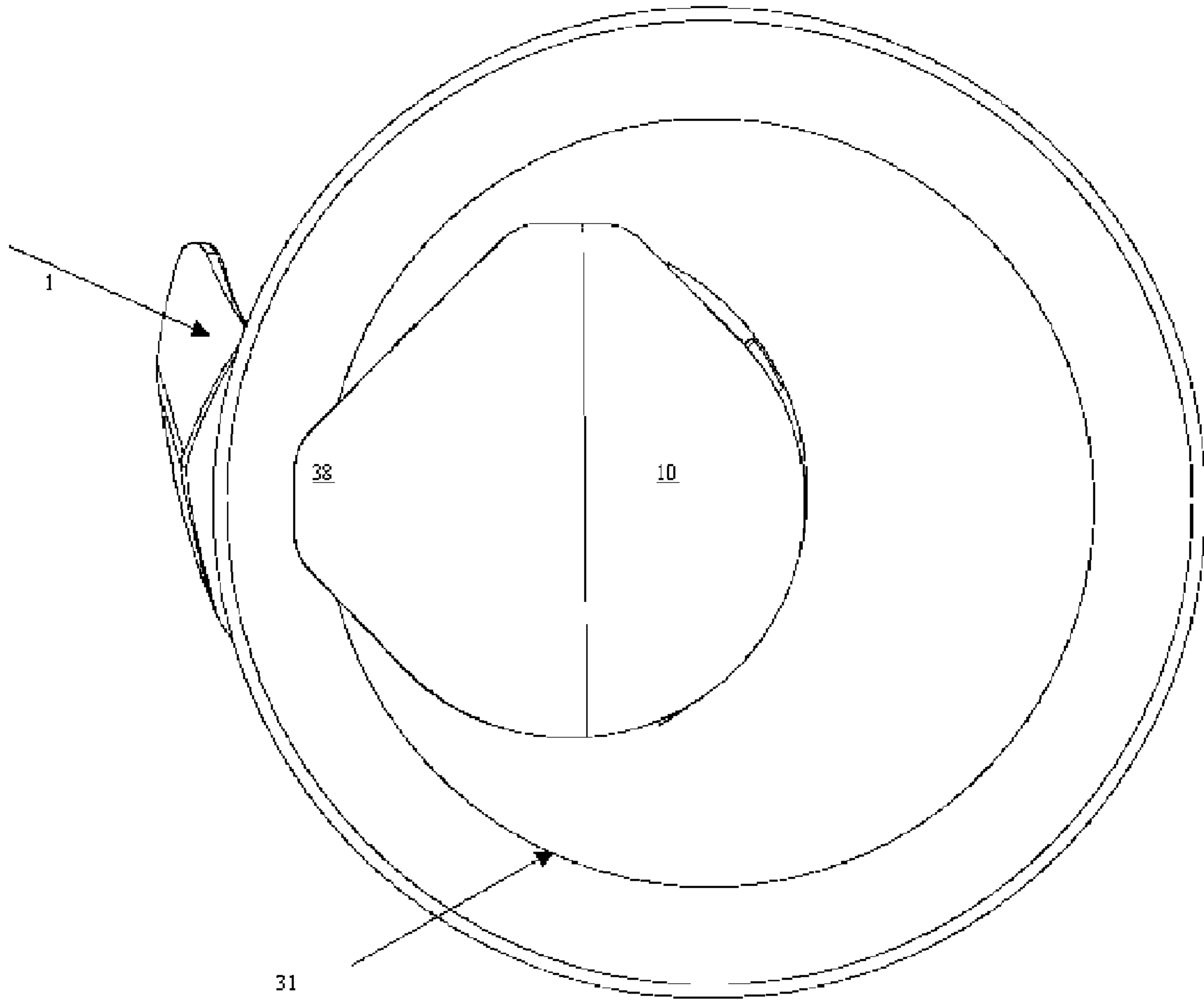

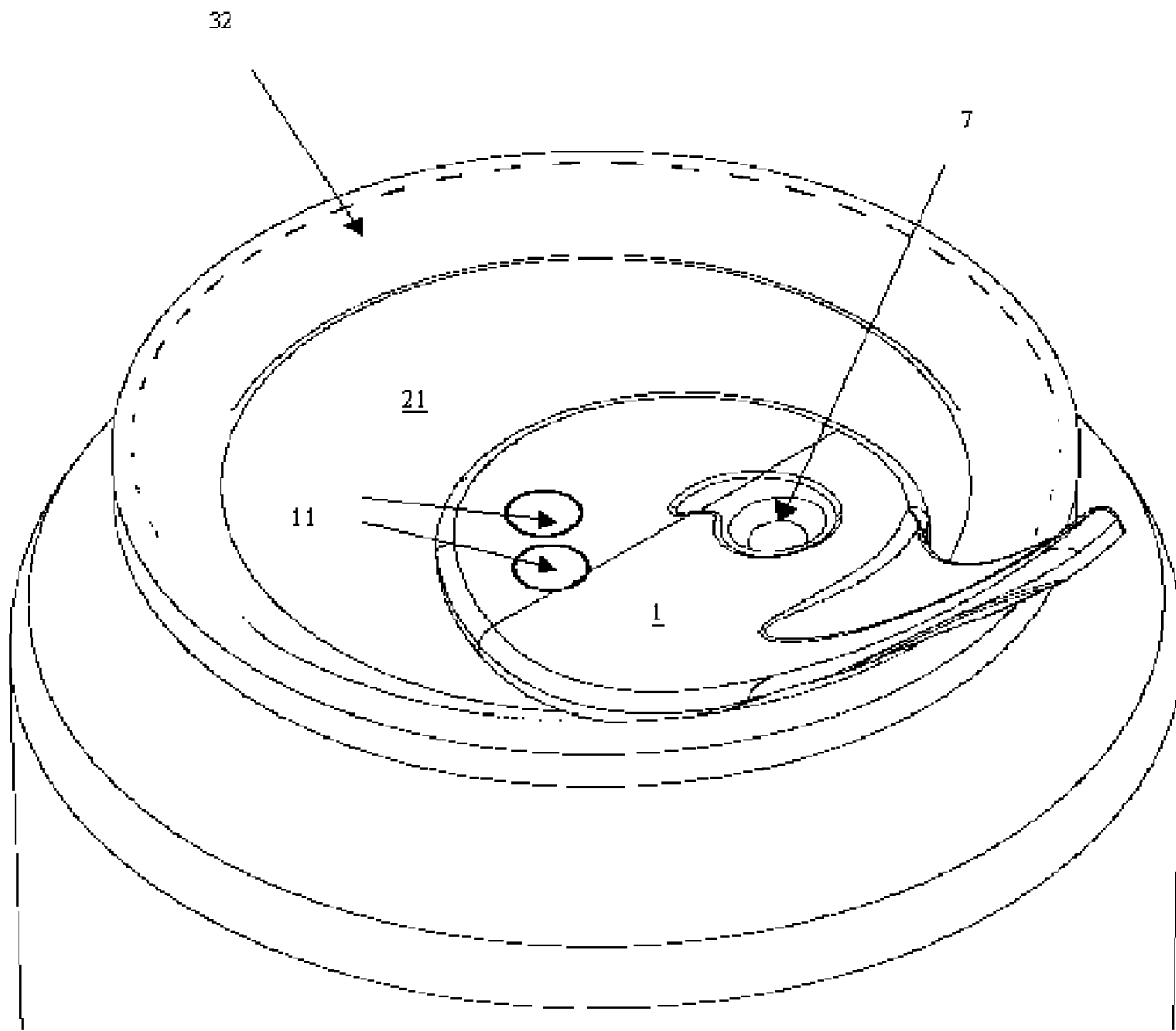

[Fig. 0017]

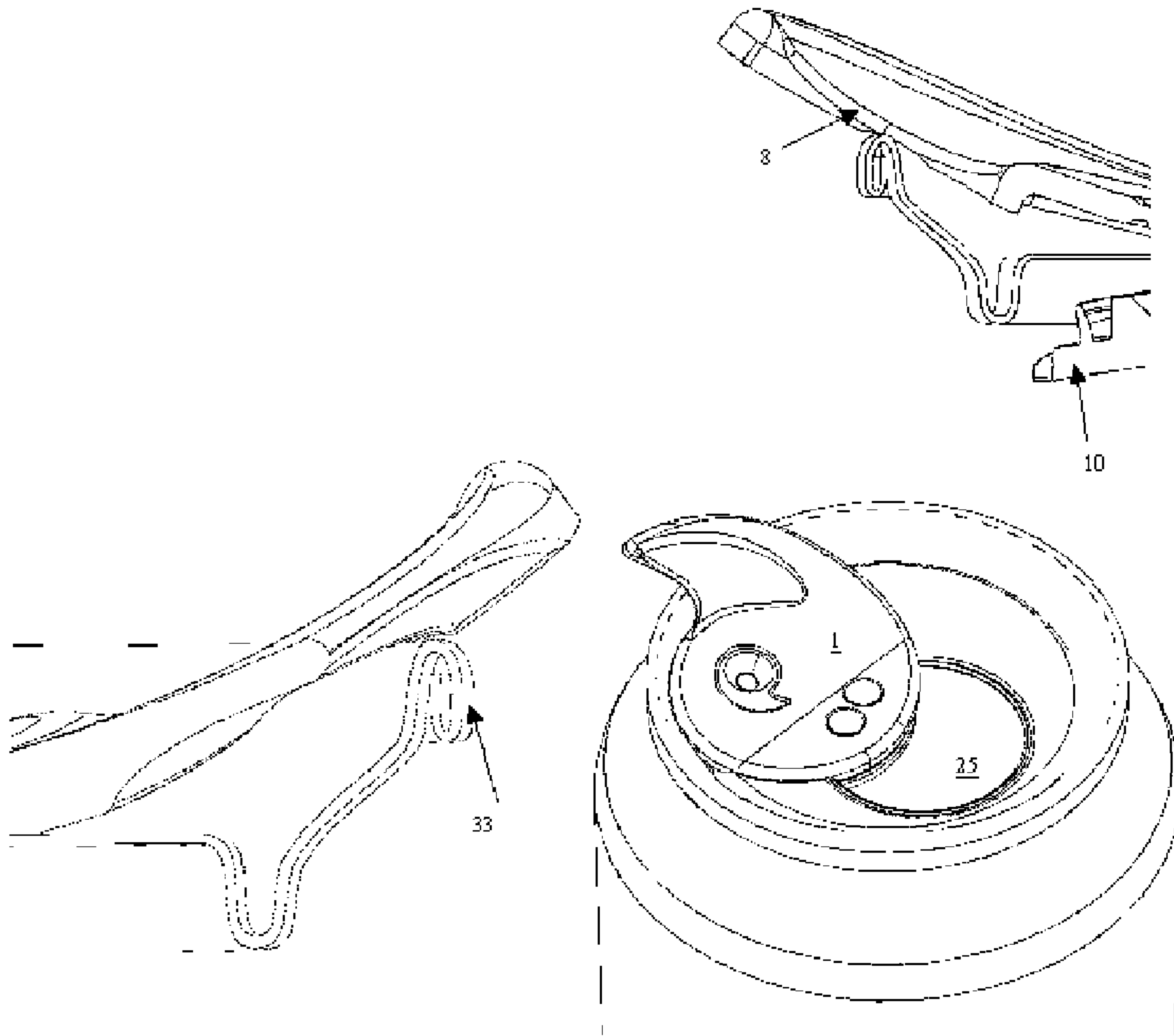

[Fig. 0018]

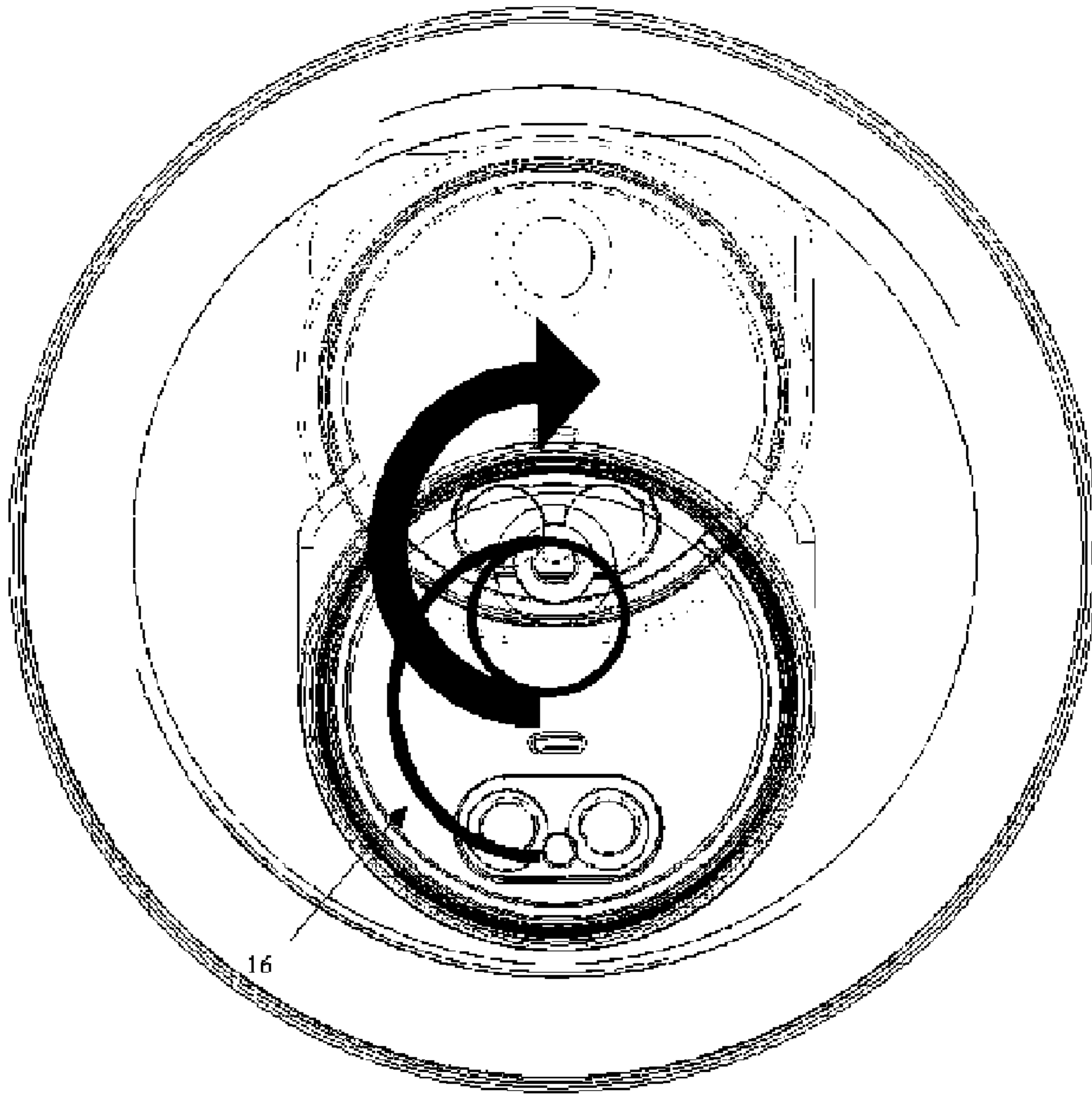

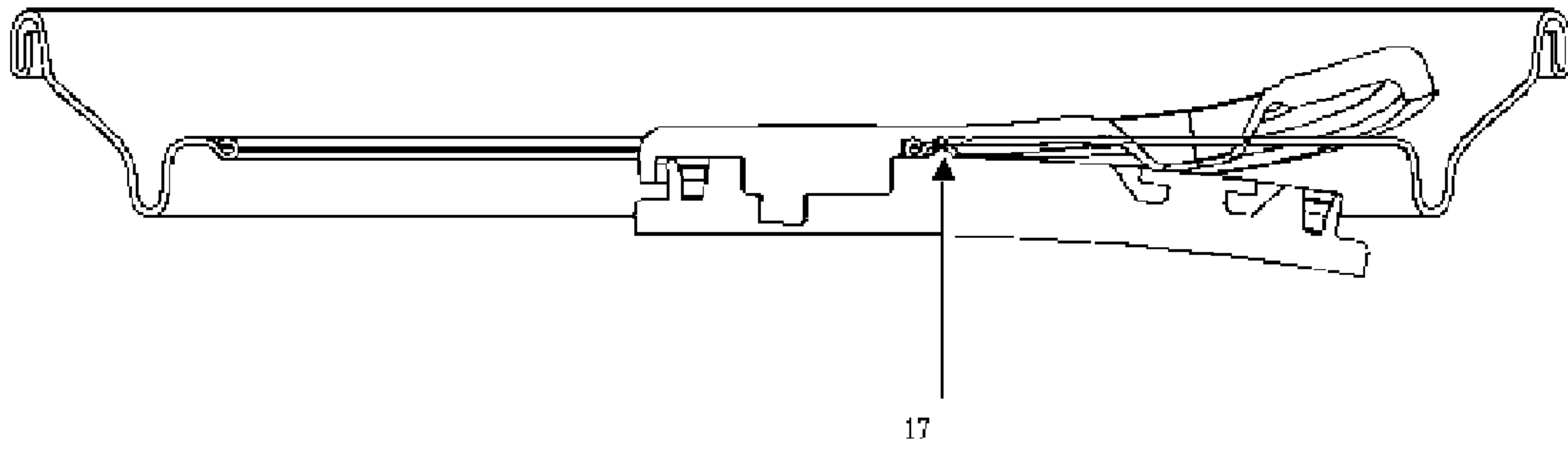



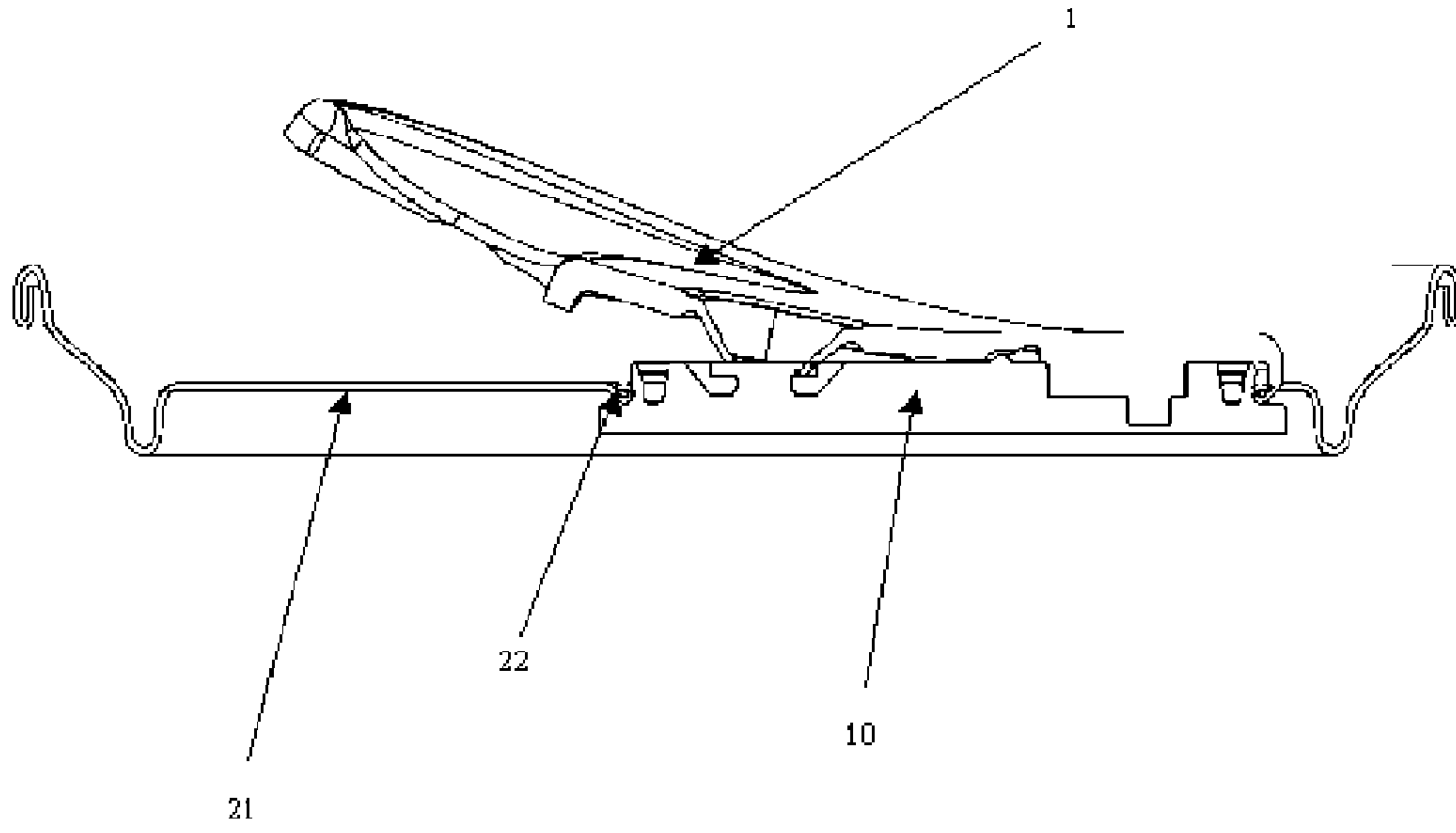

88

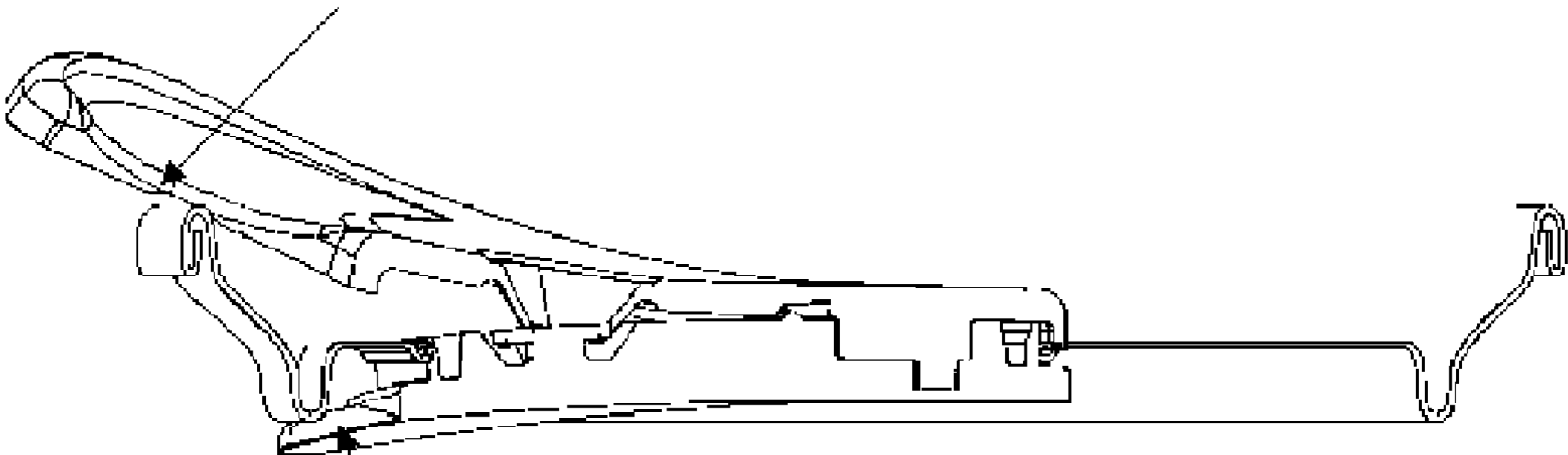

38