

(12) PATENT
(19) AUSTRALIAN PATENT OFFICE

(11) Application No. AU 199710613 B2
(10) Patent No. 714296

(54) Title
Method and system for presenting customized promotional offers

(51)⁶ International Patent Classification(s)
G06F 017/60

(21) Application No: 199710613 (22) Application Date: 1996 .11 .27

(87) WIPO No: W097/20279

(30) Priority Data

(31) Number	(32) Date	(33) Country
08/561338	1995 .11 .30	US

(43) Publication Date : 1997 .06 .19
(43) Publication Journal Date : 1997 .08 .14
(44) Accepted Journal Date : 1999 .12 .23

(71) Applicant(s)
Inter*Act Systems, Incorporated

(72) Inventor(s)
Paul A. Nash; William F. Penwell; Michael R Jones

(74) Agent/Attorney
WATERMARK PATENT and TRADEMARK ATTORNEYS, Locked Bag 5, HAWTHORN VIC 3122

(56) Related Art
US 5353218
US 5056019
US 5327508



INT

<p>(51) International Patent Classification 6 : G06F 17/60</p>	<p>A1</p>	<p>(11) International Publication Number: WO 97/20279 (43) International Publication Date: 5 June 1997 (05.06.97)</p>
<p>(21) International Application Number: PCT/US96/18930 (22) International Filing Date: 27 November 1996 (27.11.96) (30) Priority Data: 08/561,338 30 November 1995 (30.11.95) US (71) Applicant: INTER*ACT SYSTEMS, INCORPORATED [US/US]; 14 Westport Avenue, Norwalk, CT 06851 (US). (72) Inventors: NASH, Paul, A.; 1010 Catamount Road, Fairfield, CT 06430 (US). PENWELL, William, F.; 18 Mayo Avenue, Greenwich, CT 06870 (US). JONES, Michael, R.; 23 Palmer Hill Road, Old Greenwich, CT 06830 (US). (74) Agents: LIPSITZ, Randy et al.; Brown Raysman Millstein Felder & Steiner L.L.P., 120 West 45th Street, New York, NY 10036 (US).</p>	<p>(81) Designated States: AL, AM, AT, AU, AZ, BA, BB, BG, BR, BY, CA, CH, CN, CU, CZ, DE, DK, EE, ES, FI, GB, GE, HU, IL, IS, JP, KE, KG, KP, KR, KZ, LC, LK, LR, LS, LT, LU, LV, MD, MG, MK, MN, MW, MX, NO, NZ, PL, PT, RO, RU, SD, SE, SG, SI, SK, TJ, TM, TR, TT, UA, UG, UZ, VN, ARIPO patent (KE, LS, MW, SD, SZ, UG), Eurasian patent (AM, AZ, BY, KG, KZ, MD, RU, TJ, TM), European patent (AT, BE, CH, DE, DK, ES, FI, FR, GB, GR, IE, IT, LU, MC, NL, PT, SE), OAPI patent (BF, BJ, CF, CG, CI, CM, GA, GN, ML, MR, NE, SN, TD, TG).</p> <p>Published With international search report.</p>	

(54) Title: METHOD AND SYSTEM FOR PRESENTING CUSTOMIZED PROMOTIONAL OFFERS

(57) Abstract

A computerized system for presenting promotional offers customized to individual consumers includes one primary machine (14) including a data processing unit (34) coupled to a storage device (36) for storing individual consumer preference information, product information, and customized promotional offer information. A secondary machine (12) is adapted to receive the customized promotional offer information from the primary machine and to present customized offers and accumulate promotional offer selection information in response to consumer interaction therewith. The secondary machine transmits the offer selection information to the primary machine. A plurality of point of sale terminals (16) accumulate consumer transaction information which is in turn transmitted to the primary machine. The primary machine stores the individual offer selection information and individual consumer brand purchase information and generates an individual consumer profile. Then the primary machine generates customized promotional offer information based on the individual consumer file and product promotion information.

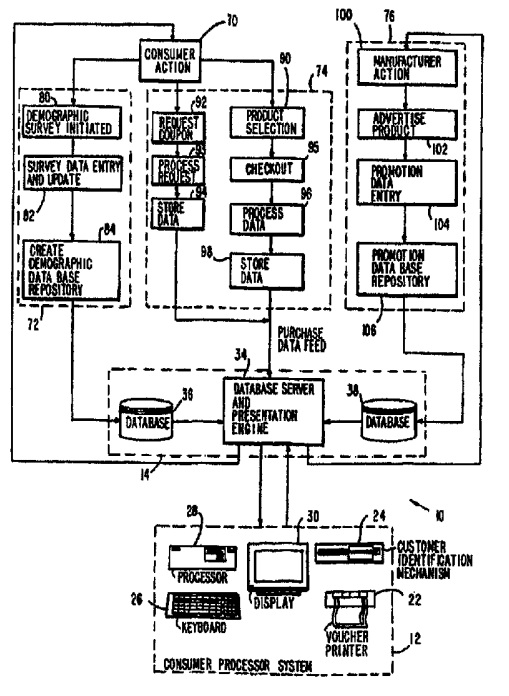

METHOD AND SYSTEM FOR
PRESENTING CUSTOMIZED PROMOTIONAL OFFERS

BACKGROUND OF THE INVENTION

This invention relates to a computerized system for presenting promotional offers, and in particular, to a system that creates a profile of individual consumers and tailors promotional offers to each individual consumer based on the consumer's profile and product promotion information generated by management.

There are many different types of consumers, some of which shop based primarily on brand name, while others shop based primarily on price. Over the years, large manufacturers have competed for brand loyalty, and have historically been able to influence consumers and gain consumer loyalty through advertising and promotion of their products. A primary means of promotion has been through the medium of couponing. It is estimated that less than 1% of magazine coupons are redeemed; 1.8% of newspaper coupons are redeemed; and 3.8% of direct mail coupons are redeemed by consumers. Accordingly, product manufacturers who spend a great deal of money on coupons desire to increase consumer redemption of coupons. Also, manufacturers desire to increase the effectiveness of promotional money spent by customizing offers to specific consumers based on consumer profiles.

Computerized couponing systems are known in the prior art as exemplified in US Patent No. 4,554,446 (Murphy, et al.). This prior art couponing system provides for the validated redemption of coupons presented at checkout, and may be provided as a front-end couponing system where coupons are

issued based on consumer interaction at the beginning of the shopping event. This patent discloses a combined coupon distribution and inventory control system. This early patent laid the ground work for consumer generation of coupons electronically, and for the electronically generated coupons to be scanned electronically at the check-out to ensure compliance with the terms of the promotion. However, the patent does not teach a way of customizing offers to target particular consumers based on consumer profiles.

A second prior art couponing system was the subject of three related patents, US Patent Nos. 4,723,212 (Mindrum et al.); 4,910,672 (Off, et al.); and 5,173,851 (Off, et al.). These three related patents are directed to a system also based on consumer interaction and may be provided as a back-end couponing system. A back-end couponing system provides consumers with coupons at the end of the shopping event. For example, the consumer walks through a supermarket and gathers products. At check-out, the products are scanned and the store controller indicates the price, etc. A memory device is provided for recording the terms of at least one coupon deal. Then, when a triggering product is scanned, it automatically causes a coupon to be printed. Accordingly, a coupon is printed in response to consumer interaction through the purchase of a triggering product.

The prior art couponing systems have made preliminary attempts and set preliminary ground work for the printing and handling of coupons in store locations in accordance with some consumer activity. The consumer activity could be a consumer

choosing the coupon from a kiosk screen (front-end), or purchasing a triggering product (back-end). However, none of the prior art couponing systems have developed customized individual computer databases based on consumer purchase characteristics.

Accordingly, it is desirable to provide a couponing system which overcomes the shortcomings of the prior art configurations described above.

SUMMARY OF THE INVENTION

Generally speaking, in accordance with the invention, a computerized system for presenting customized promotional offers to individual consumers is provided. Promotional offers include product discounts, discount coupons, vouchers, advertising messages or any other promotional message that attempts to modify consumer purchase behavior. The system includes at least one primary machine including data processing unit coupled to a storage device for storing individual consumer preference information. At least one secondary machine is adapted to receive the customized offer information from the primary machine and to produce customized offers and offer selection information in response to consumer interaction therewith. The at least one secondary machine transmits the consumer offer selection information to the at least one primary machine. A plurality of point of sale terminals are provided and each includes a member for accumulating consumer transaction information from check-out including consumer brand purchase information. Transaction

information is transmitted by the accumulating member to the at least one primary machine. The at least one primary machine stores the individual offer selection information and consumer transaction information and generates an individual consumer profile. Then, the at least one primary machine generates customized promotional offer information based on the individual consumer profile and product information.

The present invention is designed such that the primary machine (a computer) includes storage (memory) where individual consumer data is stored. The data is received at least in part from the secondary machines and the point of sale terminals. The secondary machines present the offers available for consumer selection, and summarize selection information for transmission to the primary machine. The point of sale terminals transmit to the primary machine (in the transaction information) the products purchased by the consumer, and customized offers the consumer accepted.

Accordingly, it is an object of the invention to provide an improved presentation mechanism that displays customized promotional offers targeted to individual consumers.

Another object of the invention is to categorize consumers based on purchase quantities and brand loyalty.

Yet another object of the invention is to use consumer profile information to present offers that are designed to persuade consumers toward the purchase and trial of new brand products.

Still another object of the invention is to present offers on products that the consumer does not have a history of purchasing.

A further object of the invention is to provide a presentation mechanism for promotional offers that can be accessed by a consumer at the consumer's home or office by using a personal or other computer as the secondary machine.

Still other objects and advantages of the invention will in part be obvious and will in part be apparent from the specification.

The invention accordingly comprises the several steps and the relation of one or more of such steps with respect to each of the others, and the apparatus embodying features of construction, combinations of elements and arrangements of parts which are adapted to effect such steps, all as exemplified in the following detailed description, and the scope of the invention will be indicated in the claims.

BRIEF DESCRIPTION OF THE DRAWINGS

For a fuller understanding of the invention, reference is had to the following description taken in connection to the accompanying drawings, in which:

Fig. 1 is a block diagram of a preferred embodiment of the apparatus for presenting customized promotional offers:

Fig. 2 is a schematic block diagram illustrating information flow patterns; and

Figs. 3A and 3B are flow charts illustrating the logic steps of the method of the present invention.

DETAILED DESCRIPTION OF THE PREFERRED EMBODIMENTS

Reference is first made to Fig. 1, which illustrates the preferred embodiment of the apparatus for presenting customized promotional offers which is generally indicated at 10. The apparatus includes three main portions, the primary machine 14, at least one secondary machine 12 (only one machine is shown) and at least one point of sale terminal 16 (only one is shown).

Primary machine 14 is the central portion of the system and includes a database server and presentation engine 34 coupled to a manufacturer database 38 and a consumer database 36. Information is provided to database server and presentation engine 34 on an ongoing basis in order to update manufacturer database 38. Furthermore, the database server and presentation engine 34 continuously updates consumer database 36 based on offer selection information by the consumer through use of a secondary machine 12, and consumer purchases recorded through point of sale terminals 16.

The secondary machines 12 are preferably kiosks located at in-store locations. These are generally known in the art as front-end couponing terminals. Each secondary machine 12 includes a processor 28 that is coupled to a display 30, data input terminal 26, consumer ID terminal 24, coupon printer 22 and storage device 32. The processor is not required to be very powerful, and can be a single purpose processor, rather than a multipurpose processor. However, in the preferred embodiment, the processor in each secondary machine 12 is a conventional CPU, such as a Pentium processor produced by

Intel. Processor 28 is coupled to display 30, such as a conventional computer monitor used with a home computer. The processor is coupled to a data input terminal 26 which can be a keyboard, a touch screen, a mouse, or a combination thereof.

Optionally, a consumer ID terminal 24 is provided.

Consumer ID input terminal 24 can be some type of magnetic stripe reader for use with consumer ID cards. Each consumer ID card is preferably similar to a credit card and includes a magnetic stripe that indicates the identification of the user. Other options are that each consumer may simply have an identification number, so that no ID card is required, or the ID card can include a bar code that is readable by a scanner.

Storage device 32 is provided to temporarily store consumer data, and promotion information, as well as screen displays and the like used by the kiosk. Finally, after the consumer chooses a particular offer, it is printed by coupon printer 22.

In a retail store scenario, after the consumer receives coupons and shops throughout the store, the consumer checks out at point of sale terminals 16. Point of sale terminal 16 is generally an electronic cash register check-out system which includes a central processor 40 which is coupled to a cash register 44, a scanner 46, a storage device 48 and optionally a system ID scanner 42. Cash register 44 includes a data input device such as a keyboard, mouse, display screen and the like. The consumer ID scanner 42 is similar to that of consumer ID input terminal 24 of secondary machine 12, and includes means for reading the magnetic stripe on an ID card

or may optionally include a bar code scanner in a system where a bar code is used to identify the consumer, rather than a magnetic stripe.

Scanner 46 is a conventional scanner as used in conventional check-out systems to read the UPC codes on products during check-out. Storage device 48 is memory in the form of ROM, RAM or can be conventional hard disk. Storage device 48 includes the check-out program, and optionally stores the consumer purchase information, temporarily, until it is transmitted to primary machine 14. Point of sale terminals 16 preferably transmit information to primary machine 14 at predetermined intervals.

It is to be understood that primary machine 14 is the central processor of the system, and preferably is located at a retail store using the system, or located centrally in the case of global consumer access. Secondary machines 12 are preferably also located at in-store locations, or, can be a personal computer in a user's home or office, and can interact with a primary machine 14 through an on-line service, or over the Internet or interactive television service. In this way, a consumer that is preparing to go shopping may determine what items he/she would like to purchase, and may access different manufacturer databases, or retail store databases, in order to determine where he/she may receive the most favorable promotional discounts.

As stated above, point of sale terminals 16 are preferably located at the check-out area of a retail store; however, point of sale terminals in an on-line system may be

at the shipping locations. For example, a catalogue company may have a point of sale terminal where the shipping department enters the products purchased, the consumer ID and the consumer discount offered at that time. This enables coupon discounts to be accessed and either printed for in-store use or transmitted over on-line services for redemption on-line.

Referring now specifically to Fig. 2, apparatus for presenting customized promotional offers 10 is illustrated in an information flow block schematic representation, and like reference numerals are used to refer to like elements.

Primary machine 14 is coupled to secondary machine 12. The elements of secondary machine 12 and primary machine 14 are described above in connection with Fig. 1, and primary machine 14 receives three types of information. There are two types of consumer data which are received in connection with consumers' actions 70. There is consumer demographic information, generally indicated at 72, and individual consumer behavior information, generally indicated at 74. Furthermore, there is manufacturer promotional data information, generally indicated at 76.

Consumer demographic and preference information 72 is received by initializing a demographic survey in step 80, proceeding to enter and update survey data in step 82 thereby creating a demographic database repository 84. The data from demographic database repository 84 is then transmitted to database server and presentation engine 34 in the form of

demographic behavioral and consumer preference data which is then entered into consumer database 36.

Furthermore, when consumers take action in step 70, individual consumer behavior information 74 is activated. Consumer action 70 takes place either by the consumer obtaining a coupon throughout the system, or making a purchase. The consumer can request a coupon in step 92, which takes place at secondary machine 12. Then the information is processed in step 93 by secondary machine data processor 28, and stored in step 94 (in storage device 32 of Fig. 1). At predetermined intervals this stored information is transmitted to database server and presentation engine 34 for transmission to consumer data storage 36.

Consumer action 70 can also result in product selection 90. The product is selected 90 and is checked out 95 at a point of sale terminal 16. Check-out 95 can either be through a cash register or scanner. The information from check-out 95 is processed in step 96 by point of purchase data processor 40. This data is temporarily stored in step 98 and is then transmitted to database server and presentation engine 34 for entry into consumer database 36.

Manufacturer promotional data information 76 considers consumer data compiled in the consumer database 36, and processed by database server and presentation engine 34, and particular information is transmitted to manufacturer promotional data information 76. Then, manufacturer actions 100 are considered. In step 102 (advertise product) the manufacturer contacts the system supplier and signs up for the

service. The particular discount coupons being offered by the manufacturer are entered onto the system in step 104 (promotion data entry). This forms a promotion database repository 106 which is transmitted to database server and presentation engine 34 for storing in manufacturer database 38.

Accordingly, a database is created that contains consumer characteristics on a demographic basis, and consumer characteristics from actual individual consumer activities. Furthermore, manufacturer discount offers are logged into a separate database. Thus, for each consumer, the database system works from the first use to customize the database based on demographic data, and the database becomes more customized as the user continues to make purchases and obtain coupons.

Reference is next made to Figs. 3A and 3B which in combination illustrate the flow of information in database server and presentation engine 34. As described above, the presentation engine receives consumer data from consumer database 36 of Fig. 1, and manufacturer data from manufacturer database 38 of Fig. 1. Manufacturer data is entered in the form of promotion availability data entry 150 (described in more detail in Fig 2). In step 152 this data is formed into a machine useable promotion and marketing database format (manufacturer database 38 of Fig. 1). Alternatively, transaction/behavioral data entry 156 and import consumer purchase/profiles 158 are constantly updated and are formed into a machine useable consumer behavioral database in step

160. As described above, transaction/behavioral data 156 is received from demographic studies, described above as consumer demographic information 72. Import consumer purchases/profiles 158 is essentially received from individual consumer behavior information 74, and the combination thereof forms consumer database 36 which is essentially the same as the consumer behavioral database formed in step 160.

The consumer presentation process is initiated in step 162 by receiving promotional and marketing database, formed in step 152, and consumer behavioral database, formed in step 160, and with the information in these databases the database server and presentation engine chooses the applicable coupons for each consumer. The information flow diagram of Figs. 3A and 3B illustrate one cycle of the presentation engine for a single consumer and the presentation engine starts at step 162 for each consumer.

The promotional offers made available by manufacturers which are listed in the promotion and marketing database formed in step 152 are reviewed one promotion at a time beginning in step 162. After step 162, a single promotion is considered in step 164 and it is determined whether any behavior from the consumer database 160 for the individual consumer being considered is associated with the promotion under consideration in step 162. If there is not any behavior from consumer database 160 that is associated with the entry in step 162, then a default presentation (offer choice) is presented in step 166. The process then loops back to step 162 to consider the next potential promotion.

Alternatively, if the answer in step 164 is "yes", then the process moves to logic block 172 and asks whether the consumer's purchasing behavior is loyal. Loyal behavior refers to the behavior of the consumer as consistently purchasing products, as defined by management, of the manufacturer whose product is now being considered. If the answer is yes the consumer is loyal, then the process moves to logic block 174 and asks whether the consumer's purchase behavior is strong or heavy. Strong or heavy behavior refers to large amounts of purchases. If the answer in logic block 174 is "yes", then the process moves to block 176 and the consumer is logged in as a heavy loyal consumer. Alternatively, if the answer is "no", then the process moves to block 178 and the consumer is logged in as a light loyal consumer. In either case, after step 176 or 178, the process moves to "A" which appears at the top of Fig. 3B.

If the answer was "no" in logic block 172 (the behavior is not loyal) then the process moves to logic block 170 and asks whether the consumer is a "switcher" in connection with the particular product. A "switcher" is defined as a person who does not have any particular brand loyalty, as defined by management, in connection with the particular product being considered. If the answer is "yes" the consumer is a "switcher", then the process moves to block 180 and asks whether the consumer is a strong or heavy "switcher". If the answer is "yes" the consumer is a heavy "switcher" then the process moves to block 182 and the consumer is logged in as a heavy "switcher". Alternatively, if the answer is "no" the

user is not a heavy "switcher", then the process moves to block 184 and the consumer is logged in as a light "switcher". In either case, after step 182 or 184, the process moves to "A" which appears at the top of Fig. 3B.

If the answer was "no" in logic block 170 (the behavior is not a "switcher"), then the process moves to logic block 168 and asks whether the consumer behavior is competitive, as defined by management, in connection with the particular product. Competitive consumer behavior is defined as a consumer behavior that is loyal to brands that are in competition with the brand now being considered for the promotion. For example, a consumer who purchases Pepsi Cola soft drinks exclusively would be categorized as a competitive user for a promotion of Coca-Cola. If the answer is "yes", the consumer behavior is competitive, then the process moves to block 186 and asks whether the consumer behavior is strong or heavy competitive, then the process moves to block 188 and the consumer is logged in as exhibiting heavy competitive behavior. Alternatively, if the answer is "no" the user does not exhibit heavy competitive behavior, then the process moves to block 190 and the consumer is logged in as exhibiting light competitive behavior. In either case, after step 188 or 190 the process moves to "A" which appears at the top of Fig. 3B.

In each scenario above after logging in the consumer's behavior characteristics the process moves to "A" which appears at the top of Fig. 3A, and moves to logic block 200. Logic block 200 asks "are there offers (coupons/vouchers/advertising messages/other) for this

promotion segment?" If there are not any offers, then the process moves to "B". "B" returns the process to step 162 in order to review the next offer in the promotion and marketing database formed in step 152.

If the answer is "yes" in logic block 200, there are offers, then the process moves to logic block 202 and asks "has the consumer not seen this offer twice with no response?" If the answer is "no", the consumer has seen this offer twice with no response, then the process moves to "B". Alternatively, if the answer is "yes", the consumer has not seen offer twice with no response, then the process moves to step 204 and the offer is added to the list of possible offers.

The process next moves to logic block 206 and asks whether the promotion and marketing database formed in step 152 is exhausted? If the database is not exhausted, then the process loops back to "A". If the database is exhausted, then the process moves to step 208 and sorts the presentation list by consumer purchase cycle. The consumer purchase cycle is one way of sorting the list of possible promotions. The consumer purchase cycle sort reviews the consumer database and determines purchase frequency for the possible promotions, and determines whether the consumer is ready for another purchase of the product based on past purchase history. For example, if the consumer purchases oven cleaner approximately every six months, and the last purchase of oven cleaner by the consumer was one month ago, then oven cleaner would be low on the purchase cycle list. Alternatively, if it had been five

months since the last purchase of oven cleaner, then it would be high on the purchase cycle list.

The process then moves to block 210 and sorts the presentation list by highest percentage of discount. This is a second sort choice, and gives more weight to coupons offering higher percentage of discounts. After block 210, the process moves to step 212 and applies a custom sort when applicable. A custom sort is a third sort option which is based on management preference. In particular, a custom sort may focus on seasonal items, such as providing candy prior to Halloween, or cranberry sauce prior to the Thanksgiving holiday. After completion of step 212 the process moves to step 214 and shows the top ranked promotions on the presentation list. The rank is based on any or all of the three sort options. In the preferred embodiment 35-40 promotions are shown; however this number is variable based on management preference.

Accordingly, the present invention provides a system for presenting promotional offers customized to individual consumers which can either be a front-end or back-end system, and the promotional offers can be obtained in store locations or over on-line computer services. The system includes a primary computer having a data processing unit coupled to memory for storing information about consumer and information concerning available promotional offers. A secondary computer receives customized offer information produced by the primary computer and presents customized offers and generates offer selection information in accordance with interaction from the

consumer. The offer selection information is then sent back to the primary machine to update the consumer profile information. Point of sale terminals are also provided to record the consumer transaction information generated at check-out for later transmission to the primary machine, so that the primary machine can update the individual consumer database.

It will thus be seen that the objects set forth above, among those made apparent from the preceding description, are efficiently attained and, since certain changes may be made in carrying out the above method and in the construction set forth without departing from the spirit and scope of the invention, that is intended that all matter contained in the above description and shown in the accompanying drawings shall be interpreted as illustrative and not in a limiting sense.

It is also to be understood that the following claims are intended to cover all of the generic and specific features of the invention herein described and all statements of the scope of the invention which, as a matter of language, might be said fall there between.

THE CLAIMS DEFINING THE INVENTION ARE AS FOLLOWS:

1. A system for making customised promotional offers available to individual consumers, including:

at least one primary machine including a data processing unit coupled to a storage device for storing individual consumer preference information, product information and customised promotional offer information;

at least one secondary machine adapted to receive said customised promotional offer information from said primary machine and present customised promotional offers while generating promotional offer selection information in response to consumer interaction;

said at least one secondary machine transmitting said promotional offer selection information to said at least one primary machine;

a plurality of point of sale terminals including means for accumulating consumer transaction information;

said accumulating means being adapted to transmit said consumer transaction information to said at least one primary machine;

said at least one primary machine storing said individual promotional offer selection information and individual consumer transaction information, and generating an individual consumer profile; and

said at least one primary machine generating customised promotional offer information based on said individual consumer profile and said product information.

2. The system for making customised promotional offers of claim 1, wherein said system categorises each consumer based on past purchase history of particular products.

3. The system for making customised promotional offers of claim 2, wherein said system categorises the consumers based on the quantity of goods purchased by the consumer.

4. The system for making customised promotional offers of claim 2, wherein said system categorises the consumers based on the consumers' brand loyalty.



5. The system for making customised promotional offers of claim 2, wherein said system creates a list of possible promotions.

6. The system for making customised promotional offers of claim 5, wherein said list of possible promotions is sorted based on the consumer purchase cycle information.

7. The system for making customised promotional offers of claim 6, wherein said consumer purchase cycle information is obtained from said individual consumer profile.



8. The system for making customised promotional offers of claim 5, wherein said list of possible promotions is sorted based on the percentage of discount offered in the promotional offers.

9. A method of customising promotional offers to individual consumers, including the steps of:

obtaining individual consumer preference information including promotional offers presented, selected and redeemed;

storing said individual consumer preference information in a storage means;

inputting, by an input means, manufacturer promotional availability information;

storing said manufacturer promotional availability information in said storage means;

classifying consumer behaviour with respect to each stored manufacturer promotion available;

ranking available promotional offers based on predetermined parameter; and

presenting a predetermined number of the top ranked promotional offers to each individual consumer.



10. The method of customising promotional offers of claim 9, wherein said individual consumer preference information includes demographic data.

11. The method of customising promotional offers of claim 9, wherein said individual consumer preference information includes part promotional offers requested.

12. The method of customising promotional offers of claim 9, wherein said individual consumer preference information includes consumer purchase history information.

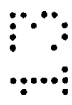

13. The method of customising promotional offers of claim 9, wherein said classifying step includes classifying said consumer behaviour in connection with brand loyalty.



14. The method of customising promotional offers of claim 9, wherein said classifying step includes classifying said consumer behaviour in connection with consumer purchase quantities.



15. The method of customising promotional offers of claim 13, wherein said classifying step includes classifying said consumer behaviour in connection with purchase quantities.



16. The method of customising promotional offers of claim 9, wherein said ranking is based on consumer purchase cycle information.



17. The method of customising promotional offers of claim 9, wherein said ranking is based on the percentage of discount offered in the promotional offers.

18. The method of customising promotional offers of claim 9, further including the step of selecting promotional offers from those presented.

19. The method of customising promotional offers of claim 18, further including the step of printing the selected promotional offers.



20. A method of presenting customised promotional offers to consumers including the steps of presenting a plurality of promotional offers to a consumer, storing, in a storage means, a list of the promotional offers selected by the consumer from the plurality of promotional offers presented, storing, in said storage means, a list of the promotional offers redeemed by the consumer from the promotional offers selected by the consumer, and generating an updated list of promotional offers to be presented to said consumer based on the list of promotional offers presented to and selected by the consumer and the list of promotional offers redeemed by the consumer.



21. The method of presenting customised promotional offers to consumers as claimed in claim 20, wherein the steps of presenting a plurality of promotional offers and selecting from the plurality of promotional offers are performed at in-store locations.

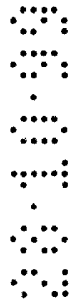

22. The method of presenting customised promotional offers as claimed in claim 21, wherein said steps of presenting a plurality of promotional offers and selecting from the plurality of promotional offers are performed at an in-store kiosk.



23. The method of presenting customised promotional offers as claimed in claim 20, wherein said step of presenting a plurality of promotional offers is performed at an out-of-store location.



24. The method of presenting customised promotional offers as claimed in claim 23, wherein said step of selecting from the plurality of promotional offers is performed at an out-of-store location.

25. The method of presenting customised promotional offers as claimed in claim 24, wherein said steps of presenting and selecting are performed on a personal computer.



26. The method of presenting customised promotional offers as claimed in claim 25, wherein said steps of presenting and selecting are performed through an on-line computer service.

27. A method of presenting customised promotional offers to consumers including the steps of identifying a consumer, presenting a plurality of promotional offers to said consumer, storing, in a storage means, a list of the promotional offers presented to said consumer, storing, in said storage means, a list of the products purchased by said consumer, analysing the products purchased by said consumer, and generating an updated list of promotional offers to be presented to said consumer based on the list of products purchased by said consumer.



28. The method of presenting customised promotional offers to consumers as claimed in claim 27, further including the steps of storing a list of the promotional offers selected by the consumer from the plurality of promotional offers presented.



29. The method of presenting customised promotional offers as claimed in claim 28, wherein said steps of presenting a plurality of promotional offers and selecting from the plurality of promotional offers are performed at an in-store kiosk.



30. The method of presenting customised promotional offers as claimed in claim 27, wherein said step of presenting a plurality of promotional offers is performed at an out-of-store location.

31. The method of presenting customised promotional offers as claimed in claim 30, wherein said step of selecting from the plurality of promotional offers is performed at an out-of-store location.

32. The method of presenting customised promotional offers as claimed in claim 31, wherein said steps of presenting and selecting are performed on a personal computer.



33. The method of presenting customised promotional offers as claimed in claim 32, wherein said steps of presenting and selecting are performed through an on-line computer service.

34. A method of presenting customised promotional offers to consumers including the steps of identifying a particular consumer from the group of consumers, presenting at least one promotional offer to said particular consumer, storing, in a storage means, a list of the at least one promotional offer presented to said consumer, identifying the products purchased by said consumer and generating consumer transaction information in response thereto, and generating an updated list of promotional offers to be presented to said consumer based on said consumer transaction information.



35. The method of presenting customised promotional offers to consumers as claimed in claim 34, wherein said consumer transaction information includes a list of products purchased by said consumer as a result of said at least one promotional offer redeemed by said consumer.

36. The method of presenting customised promotional offers as claimed in claim 35, wherein said step of presenting at least one promotional offer is performed at an in-store kiosk.



37. The method of presenting customised promotional offers as claimed in claim 34, wherein said step of presenting a plurality of promotional offers is performed at an out-of-store location.

38. The method of presenting customised promotional offers as claimed in claim 37, further including the step of determining whether said consumer has selected said at least one promotional offer.

39. The method of presenting customised promotional offers as claimed in claim 34, wherein said step of presenting said at least one promotional offer is performed on a personal computer.



40. The method of presenting customised promotional offers as claimed in claim 39, wherein said step of presenting is performed through an on-line computer service.

DATED this 22nd day of October, 1999.

INTER*ACT SYSTEMS, INC.

WATERMARK PATENT & TRADEMARK ATTORNEYS
4TH FLOOR "DURACK CENTRE"
263 ADELAIDE TERRACE
PERTH WA 6000

D
O
S
E

S
E
E
S
E



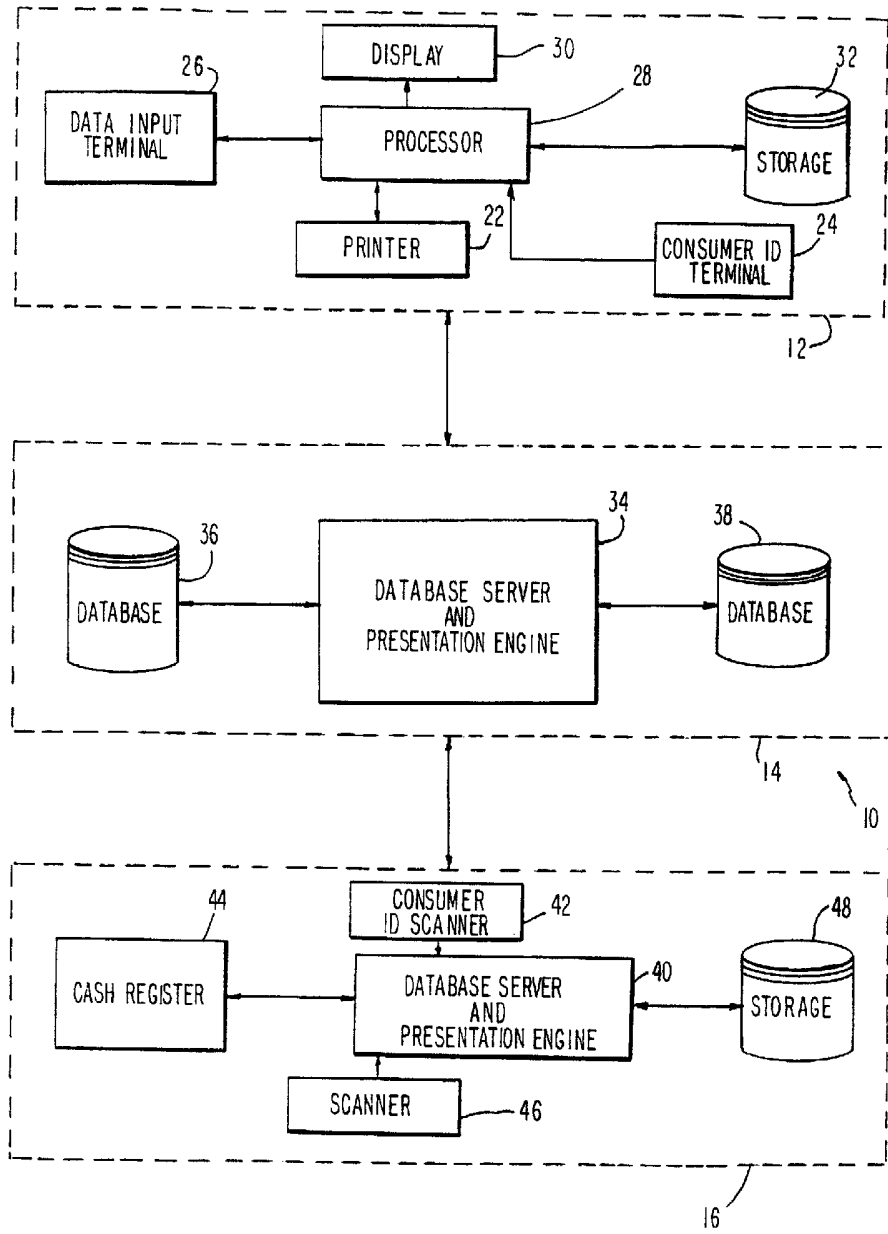

FIG. 1

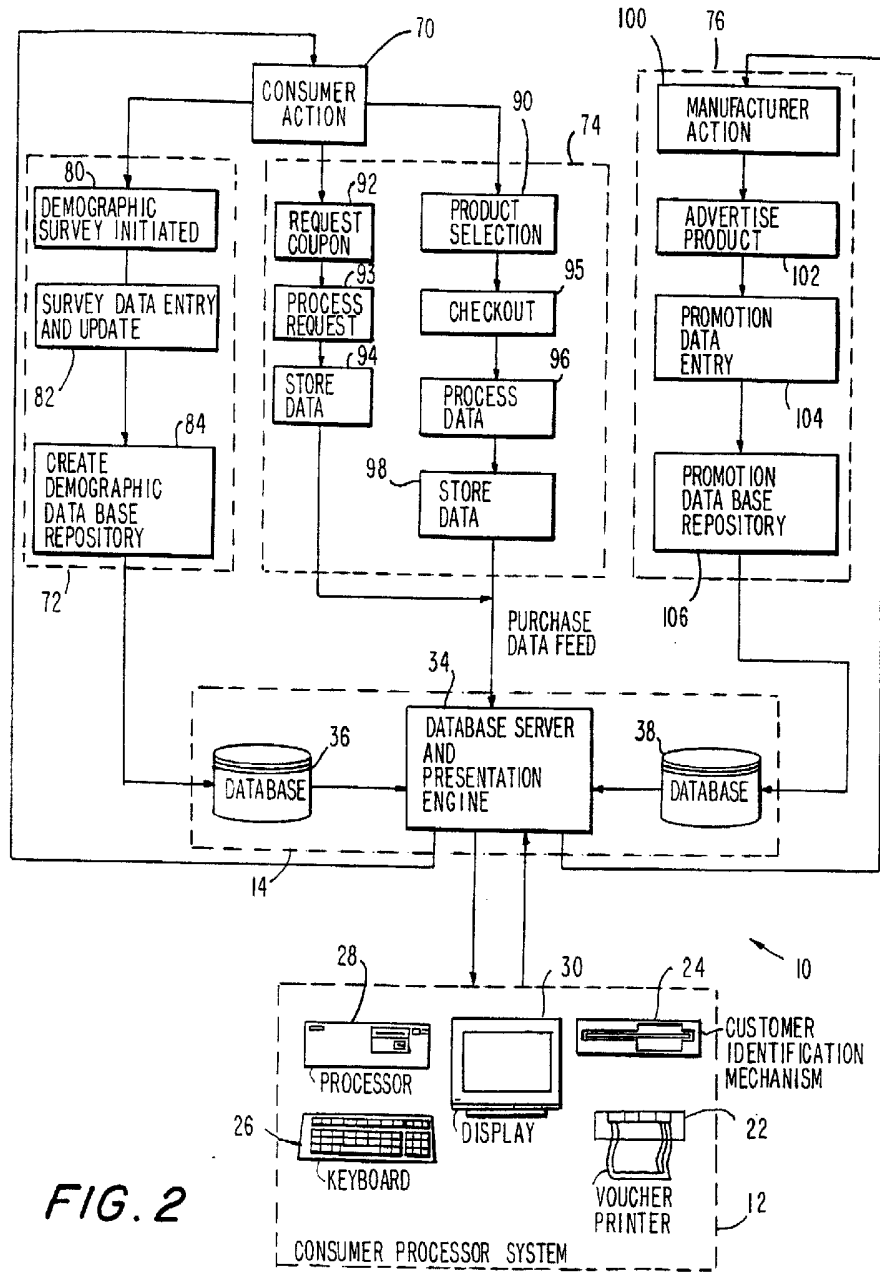

FIG. 2

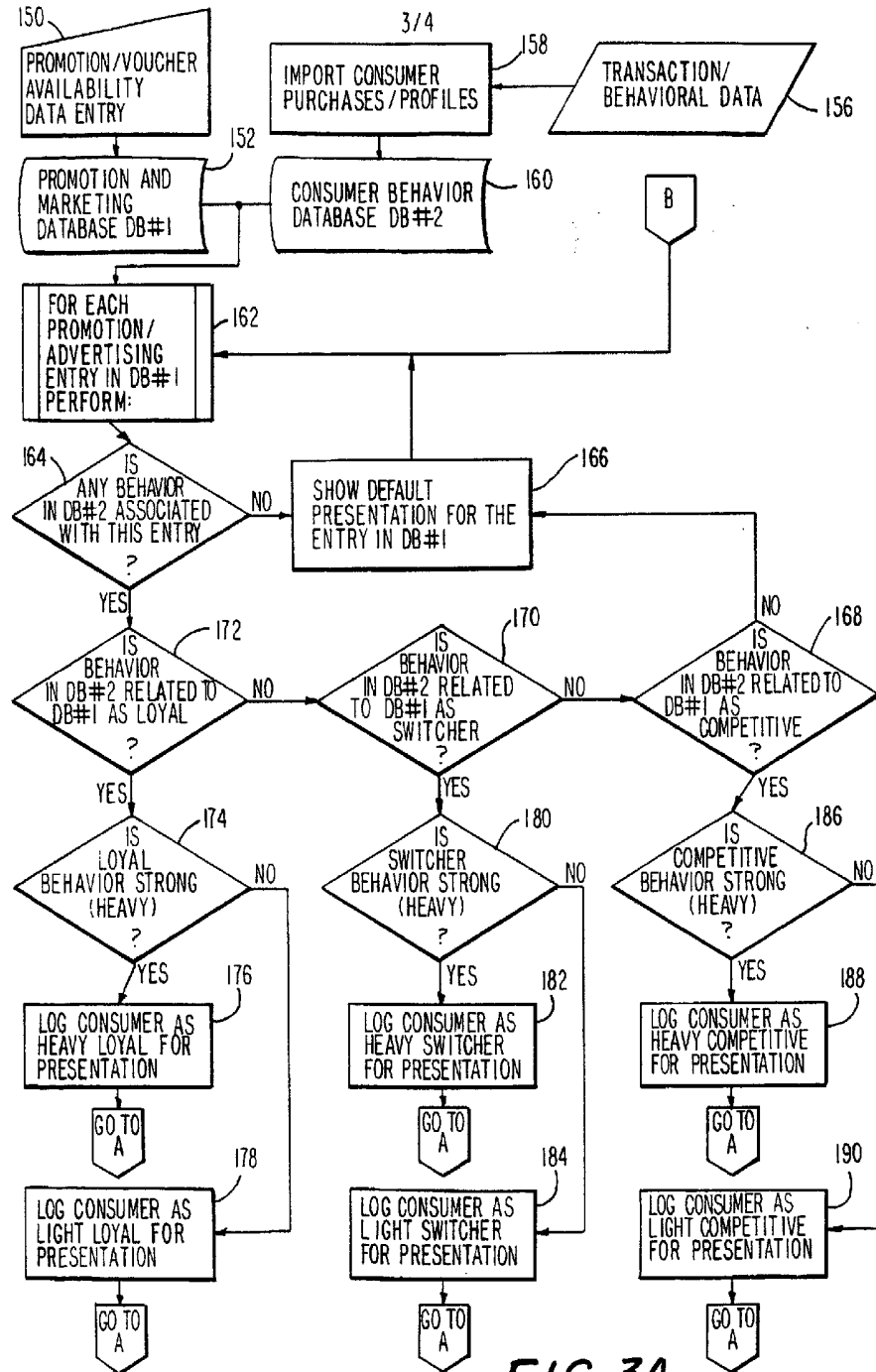

FIG. 3A

FIG. 3B

