

1 597 354

(21) Application No. 18261/76 (22) Filed 4 Oct. 1976

(23) Complete Specification filed 22 Dec. 1977

(44) Complete Specification published 9 Sept. 1981

(51) INT. CL.³ C05 9/04 9/02

(52) Index at acceptance

C1B 12

(54) AEROBIC, THERMOPHILE FERMENTATION OF ORGANIC WASTE MATERIALS



(71) I, VICTOR STAHLSCHMIDT, a Danish subject of Seestrasse 220, CH 8002 Zürich, Switzerland, do hereby declare the invention, for which I pray that a patent may be granted to me, and the method by which it is to be performed, to be particularly described in and by the following statement:—

The invention relates to a method of, and an apparatus for, aerobic, thermophile fermentation of organic waste materials such as domestic or industrial refuse with or without addition of sewage sludge.

According to the invention there is provided a method of aerobic, thermophile fermentation of organic waste materials, wherein the waste materials are stored as a stationary mass and an aeration medium comprised predominantly of air is passed through the mass with there being at least partial recirculation of the medium within the mass and with the aeration medium being heated by passage through part of the fermenting mass, the aeration medium being recirculated at a temperature of at least 40°C and being passed through the mass in such volume as to prevent the temperature in the fermenting mass rising above 60°C.

The method according to the invention is inter alia based on the recognition that the heat produced by the biological oxidation must be removed from all parts of a fermenting mass at a rate sufficient to prevent the temperature to rise beyond an upper limit for the fermentation conditions in order not to delay or interrupt the process of fermentation. The thermal conductivity of solid waste materials is low, and by far the greatest part of the heat generated by the process of fermentation can only be removed and transferred by evaporation and condensation of water and transfer of water vapour. The quantity of aeration medium necessary for transfer of the heat in form of water vapour is more than one order of magnitude larger than the amount of air necessary to supply the equivalent amount of oxygen for the fermentation.

In a preferred embodiment of the method

the mass of waste material has an outer surface exposed to the atmosphere and is supported with one portion thereof over a zone of reduced pressure and another portion thereof over a zone of superatmospheric pressure, aeration medium being sucked from the reduced pressure zone and fed under pressure to the superatmospheric pressure zone whereby air is sucked from the atmosphere through the one portion as aeration medium, during which time it is heated, and is then forced into the other portion of the mass, the two portions of the mass being contiguous whereby part of the aeration medium passing through said other portion recirculates directly into said one portion within the mass without passing to atmosphere.

Periodically the direction of flow of aeration medium through the mass may be reversed with the zone beneath the one portion having superatmospheric pressure and the zone beneath the other portion being at reduced pressure.

Conveniently a plurality of low pressure zones and a plurality of superatmospheric pressure zones may be provided beneath a single mass of waste material.

In an alternative arrangement aeration medium leaving the upper surface of the mass is recirculated and admitted into the bottom of the mass. Preferably fresh air from the atmosphere is continually added to aeration medium leaving the upper surface of the mass for admission therewith into the bottom of the mass.

A part of the heat which must be removed from a charge in which the process of fermentation is at an advanced stage, may be used for the preheating of a charge of fresh unfermented material, while another part of the heat may be lost to the atmosphere and the rest, if any, of the heat may be eliminated by intermediary cooling during the transfer from the warmer to the colder charge. The intermediary cooling of the air can be effected by injection of water or by indirect cooling or by both.

The method of the invention can readily be used to provide an expedient way to pro-

duce air saturated with moisture at an elevated temperature but at the lower end of the optimal temperature range for fermentation, which prevents any parts of the fermenting material from becoming too cold or too dry for optimal fermentation. A part of the aeration medium moved between the charges is allowed to escape and substituted by fresh air supplying the necessary oxygen.

The invention also concerns apparatus when used to carry out the method of the invention, such apparatus comprising a porous support for a mass of fermenting waste material, means for passing aeration medium through the support into the mass, and means for conducting aeration medium leaving at least part of the mass to the means for passing it through the support.

The invention will be further explained in the following in conformity with the accompanying drawings, in which:

FIGURE 1 shows schematically a cross-section through an embodiment of the apparatus according to the invention;

FIGURE 2 shows a longitudinal section II-II of the apparatus according to Figure 1;

FIGURE 3 shows a longitudinal section III-III of the apparatus according to Figure 2;

FIGURE 4 shows schematically a cross-section through another embodiment of the apparatus according to the invention;

FIGURE 5 shows a longitudinal section IV-IV of the apparatus according to Figure 3;

FIGURE 6 shows a plan view of a third embodiment of the apparatus according to the invention;

FIGURE 7 shows a longitudinal section VII-VII of the apparatus according to Figure 6; and

FIGURE 8 shows a cross-section VIII-VIII of the apparatus according to Figure 6.

In the embodiment shown in Figures 1-3, the apparatus consists of a horizontal platform 1, an upstanding partitioning wall 2, and two underlying channels 3 for aeration medium, one channel at each side of the wall 2. Each channel 3 has a top support wall 4 which is permeable for a gaseous aeration medium, and each channel is provided with cooling means 5. Moreover, each channel is provided with discharge tubes 6 for the discharge of condensate which might have been collected in the channels. The end walls 7 of the channels 3 are perforated and provided with passages 3' so that the channels 3 communicate with channels 8 outside the walls 7. In the channels 8, a reversible fan 9 is mounted by means of which aeration medium can be sucked from one of said channels 3 and be fed to the other channel dependent on the working direction of the fan 9.

A heap 10 consisting of, or at least con-

taining a substantial proportion of, organic waste material is deposited on said platform 1, and this material is to be fermented by artificial aeration through the channels 3. The outer surface of the heap is in contact with the atmosphere.

In the example shown in Figure 1 it is assumed that the different portions of the heap deposited to opposite sides of the partitioning wall 2 are at different stages of fermentation, the portion 10a still consisting of fresh, substantially unfermented material, in which the fermentation process has not yet started or only is at its initial stage, while the process of fermentation is at an advanced stage in the heap portion 10b. This difference of stages may have been obtained by filling up the heap 10 from the right to the left in Figure 1, i.e. the material 10a being the one which has been deposited last, by artificially cooling the portion 10a with respect to portion 10b by means of an aeration medium, by blowing in preheated aeration medium into the heap portion 10b, or by a combination of two or more of these steps.

On the assumption that the process of fermentation is at an advanced stage in heap portion 10b in relation to heap portion 10a, a volume of aeration medium as indicated by arrows *a* is then transferred from heap portion 10b to heap portion 10a by means of operation of the fan 9, the aeration medium being sucked through the heap portion 10b and into the underlying channel 3, and then by means of the fan 9 being blown into the other channel 3 and admitted from beneath to the other heap portion 10a. In this way the heap portion 10a will be supplied with an aeration medium, which has become moist and been preheated during its passage through the heap portion 10b. If necessary for maintaining an optional fermentation temperature in the portion 10a, the aeration medium may be cooled by said cooling means 5.

In case the heap portion 10a is at an advanced stage of fermentation in relation to the heap portion 10b, e.g. as a result of a promotion of the fermentation in the heap portion 10a as described before, the conditions of operation may be reversed by reversing the direction of operation of the fan 9, thus sucking moist preheated aeration medium from the heap portion 10a and admitting it to the heap portion 10b, as indicated by dotted arrows *b*.

In the embodiment shown in figs. 4-5, the process of fermentation is performed in a substantially closed chamber 10. A channel 11 for the admission of aeration medium is provided beneath the chamber, the top panel 12 of the channel which is permeable for a gaseous aeration medium constituting the floor of the chamber. The channel 11 is

provided with at least one discharge tube 13 for the discharge of condensate which might have been collected in the channel. At its top, the chamber 10 is closed by a roof 14 forming a gable. The chamber can be filled with fresh organic waste material through a supply opening e.g. in the top of the chamber. This opening is not shown. In this way, the material may be deposited in a number of layers as indicated by *a, b, c*, etc.

Beneath the top portion of the roof 14, an air channel 15 is mounted which communicates with the interior of the chamber 10 through openings 16. The channel 15 is connected to one side of a fan 17, the opposite side of which is connected to the channel 11. Moreover, the channel 15 is connected to a channel 18 which leads to one side of a fan 19. The opposite side 20 of said fan 19 communicates with the atmosphere.

The chamber 10 is not absolutely airtight, but provided e.g. with passages indicated by 21, windows or doors not shown, which allow the admission of atmospheric air to the interior of the chamber 10 as described later on.

The channel 11 is provided with cooling means 22.

In operation, the chamber 10 is filled as shown with a heap of waste material to be fermented. The fan 17 operates so as to draw exhaust medium from the top space of the chamber between the upper surface of the heap and the roof 14 and to reintroduce at least part of this medium into the heap from beneath through the channel 11, as indicated by arrows *f*. A certain amount of the circulated medium is withdrawn from the channel 15 through the channel 18 by means of the fan 19 and exhausted to the atmosphere, a corresponding amount of atmospheric air being sucked into the said top space through the said passages 21, doors, windows or other leakages.

If necessary, for maintaining an optimal fermentation temperature in the heap, the aeration medium passing the channel 11 may be cooled by means of the cooling means 22. A cooling effect can also be obtained by controlling the withdrawal of medium through the channel 18, an increased withdrawal resulting in an increased sucking-in of fresh atmospheric air which normally will lower the temperature of the exhaust medium in said top space. The two modes of cooling may also be mutually combined.

Figs. 6-8 show an embodiment, in which the apparatus comprises a platform 23. A channel, generally indicated by 24, for the admission of aeration medium is provided with a top panel 25 which is permeable for a gaseous aeration medium, and which constitutes part of said platform area. The channel 24 is oblong and subdivided partly by paral-

lel longitudinal partitions 26 and 27, partly by mutually parallel transverse partitions 28 into a number of partial channels, the longitudinal partitions 26 and 27 defining two narrow channels 29 and 30 along each of the long sides of the channel 24, while the transverse partitions 28 extend between the longitudinal partitions 26 and 27 so as to define transverse partial channels 31 and 32, which alternately communicate through ports 33 with one of the narrow channels 29 and 30, respectively. The top panel 25 covers the channel area defined by the longitudinal partitions 26 and 27 and the two end walls 34 and 35 of the channel 24, while the narrow channels 29 and 30 are closed at their top. In the embodiment shown, the narrow channels 29 and 30 are at their right end mutually connected by an air duct 36, in which a fan 37 is incorporated.

In operation, waste material is heaped up over the channel 24 as indicated by 38. The free surface of the heap is in contact with the atmosphere. When operating the ventilator, aeration medium will be sucked through the zones defined by the partial channels 32. During its passage through the material mass, the aeration medium will become moist and be preheated. By means of the fan 37, the aeration medium is then admitted from beneath to the zones defined by the partial channels 31. The flowing directions of the aeration medium is indicated by arrows *g*.

Example 1

The fermentation process in a predetermined charge of organic waste material is allowed to develop without any positive treatment resulting in cooling the charge. The temperature in the charge developed by the fermentation process will rise slowly, but after having passed an optimal temperature of about 60°C, it will further rise quickly to a point at which the fermentation process will only proceed at a low speed or even stop completely.

Example 2

The fermentation process in a predetermined charge of organic waste material is allowed to develop and be controlled by aerating the waste material with an aeration medium saturated with moisture. The aeration medium is admitted at a temperature which is at the lower range of a temperature interval of about 40-60°C, and in a rate sufficient to absorb substantially all the heat produced by the fermentation of the material without allowing the saturation temperature of the aeration medium to rise beyond the upper range of said temperature interval, thus quickly obtaining a steady state temperature and maintaining said temperature throughout the charge thereby achieving an optimal rate of fermentation.

Example 3

In an embodiment of the apparatus as shown in fig. 1, a heap of organic waste material comprising two heap portions 10a and 10b as defined by means of the partitioning wall 2 is aerated by means of an aeration medium, which is passed through the channels 3 by means of the ventilator 9. The heap is approximately 2 m high, thus being substantially higher than the partitioning wall 2, approximately 60 m long and 4-5 m broad, thus containing approximately 500 m³ organic waste material to be fermented. By means of the fan 9, aeration medium is sucked into and downwardly through the heap portion 10b having an elevated temperature, and from beneath blown upwardly into the heap portion having a lower temperature than the heap portion 10b at a rate of at least 5 m³ aeration medium per hour per m³ of organic waste material. From the heap portion 10a a portion of the admitted aeration medium will escape to the atmosphere, while another portion of the aeration medium is short circuited within the interior of the heap with the first mentioned heap portion 10b. The directions of said flows of the aeration medium are indicated by arrows *a*. These flows of aeration medium will result in a cooling of the heap portion 10b, while the admission of warm aeration medium saturated with moisture, as developed by means of the fermentation process in the heap portion, to the heap portion 10a will promote the fermentation process in this portion, temperature, and consequently the evaporation being considerably increased in this portion.

In accordance with a preset time interval of e.g. 10 minutes the direction of flow of the aeration medium is changed by reversing the fan 9, the directions of flow of aeration medium now being as indicated by arrows *b*. The alternating admission of aeration medium is continued, until the organic waste material is satisfactorily fermented.

By means of a thermometer, the temperature of the aeration medium passed through the channels 3 is controlled. If the temperature is sinking below 40-50°C, the preset time interval for reversing the direction of the medium flow is reduced, while on the contrary the present time interval is extended should the temperature be rising beyond 50-60°C.

55 Example 4

A substantially closed chamber 10 as indicated in fig. 4 and fig. 5 is filled with organic waste material to an extent so as to leave a space between the upper surface of the material heap and the cover of the chamber. Aeration medium is circulated from said space through the channel 18 and reintroduced to the heap from beneath through the channel 11 by means of the fan 17, as indicated by arrows *f*, a further

amount of aeration medium being removed from said space and exhausted to the atmosphere by means of the fan 19. By means of the sub-pressure thus created in said space, a corresponding amount of fresh air is sucked into said space through adequate passages, as formerly described.

The exhaust of aeration medium by means of the fan 19 is controlled thermostatically in such a way that the temperature of the aeration medium to be introduced into the material is kept within an interval of 40-50°C.

Example 5

In an embodiment of the apparatus as shown in figs. 6-8, an oblong heap of organic waste material positioned on the platform 23 is aerated by means of an aeration medium which is passed through the channels 29 and 30 by means of the fan 37, aeration medium being sucked from the heap from beneath through the channels 30, and being introduced into the heap from beneath through the channels 29. Contrary to Example 3, the directions of flow of aeration medium is maintained unaltered seeing that the channels 29 and 30 are mutually placed close to each other. The temperature of the aeration medium to be admitted is kept within an interval of 40-50°C by varying the amount of medium passed through the channels by controlling the working speed of the fan 37.

As far as cooling of the aeration medium is concerned, it has hitherto been exemplified by sucking-in fresh atmospheric air, by using indirectly operating cooling means 5 or 22 or by altering the amount of aeration medium. The aeration medium may also be cooled by injection of a cold fluid, e.g. water or waste water into said medium.

Moreover in all examples the free surface of the waste material mass is in free contact with atmospheric air. This contact in combination with the sucking operations described will normally be sufficient to maintain a suitable oxygen content in the aeration medium. If necessary, however, fresh air from the atmosphere may be admitted to the aeration medium before introducing it into the material mass to be aerated.

WHAT I CLAIM IS:

1. A method or aerobic, thermophile fermentation of organic waste materials, wherein the waste materials are stored as a stationary mass and an aeration medium comprised predominantly of air is passed through the mass with there being at least partial recirculation of the medium within the mass and with the aeration medium being heated by passage through part of the fermenting mass before passing into another part of the fermenting mass, the aeration medium being recirculated at a temperature of at least 40°C and being passed through

the mass in such volume as to prevent the temperature in the fermenting mass rising above 60°C.

2. A method according to claim 1, wherein the mass of waste material has an outer surface exposed to the atmosphere and is supported with one portion thereof over a zone of reduced pressure and another portion thereof over a zone of superatmospheric pressure, aeration medium being sucked from the reduced pressure zone and fed under pressure to the superatmospheric pressure zone whereby the air is sucked from the atmosphere through the one portion as aeration medium, during which time it is heated, and is then forced into the other portion of the mass, the two portions of the mass being contiguous whereby part of the aeration medium passing through said other portion recirculates directly into said one portion within the mass without passing to atmosphere.

3. A method according to claim 2, wherein periodically the direction of flow of aeration medium through the mass is reversed with the zone beneath the one portion having superatmospheric pressure and the zone beneath the other portion being at reduced pressure.

4. A method according to claim 2 or 3, wherein a plurality of low pressure zones and a plurality of superatmospheric pressure zones are provided beneath a single mass of waste material.

5. A method according to claim 2, 3 or 4, wherein an upstanding partition wall extends upwardly into the mass between the or each reduced pressure zone and the or each adjacent superatmospheric pressure zone.

6. A method according to any preceding claim, wherein the mass of waste material is comprised by an unconstrained heap.

7. A method according to claim 1, wherein aeration medium leaving the upper surface of the mass is recirculated and admitted into the bottom of the mass.

8. A method according to claim 7, wherein fresh air from the atmosphere is continually added to aeration medium leaving the upper surface of the mass for admission therewith into the bottom of the mass.

9. A method according to any preceding claim, wherein the aeration medium is cooled after leaving the one part of the fer-

menting mass before passing into the other part of the fermenting mass.

10. A method according to claim 9, wherein the cooling is carried out by the addition of cold fluid into the medium.

11. A method according to claim 10, wherein the fluid is air.

12. A method according to claim 9, wherein the aeration medium is cooled by indirect cooling.

13. Apparatus when used to carry out the method of any preceding claim which comprises a porous support for a mass of fermenting waste material, means for passing aeration medium through the support into the mass, and means for conducting aeration medium leaving at least part of the mass to the means for passing it through the support.

14. Apparatus according to claim 13, wherein the means for conducting aeration medium comprises a fan for circulating aeration medium from a second porous support to the first porous support.

15. Apparatus according to claim 13, wherein a partition wall projects upwardly into the mass from a location between the two porous supports.

16. Apparatus according to claim 14 or 15, wherein a plurality of high and low pressure zones are provided alternately beneath respective porous supports beneath the mass.

17. Apparatus according to claim 13, wherein the conducting means is arranged to take aeration medium leaving the top of the mass and to feed it to the support.

18. A method of aerobic, thermophile fermentation of organic waste material according to claim 1 and substantially as herein described with reference to the accompanying drawings.

19. An apparatus when used to carry out the method of claim 1 and constructed and arranged substantially as herein described with reference to and as illustrated in Figures 1 to 3, Figures 4 and 5 or Figures 6 to 8 of the accompanying drawings.

J. A. KEMP & CO.
Chartered Patent Agents,
14 South Square,
Gray's Inn,
London, WC1R 5EU.

Fig. 1

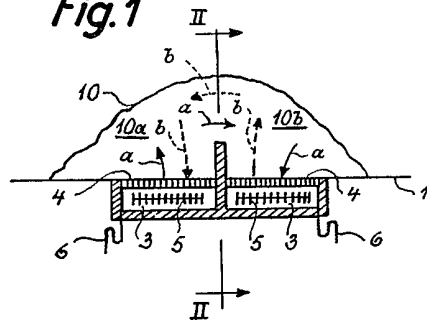

Fig. 2

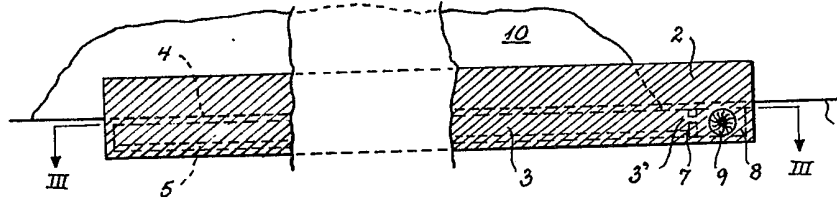

Fig. 3

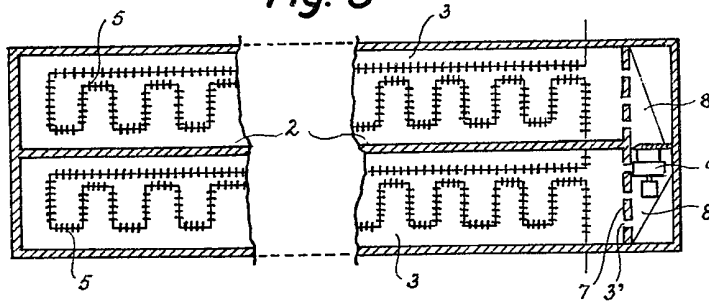

Fig. 4

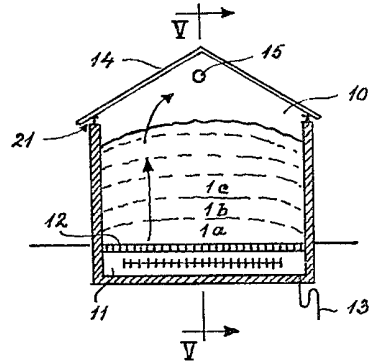

Fig. 5

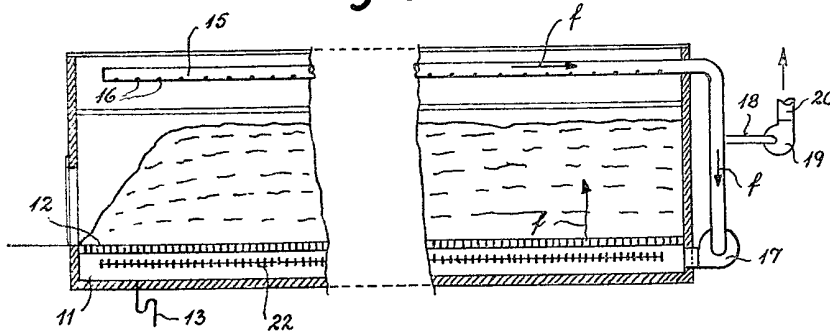

Fig. 6

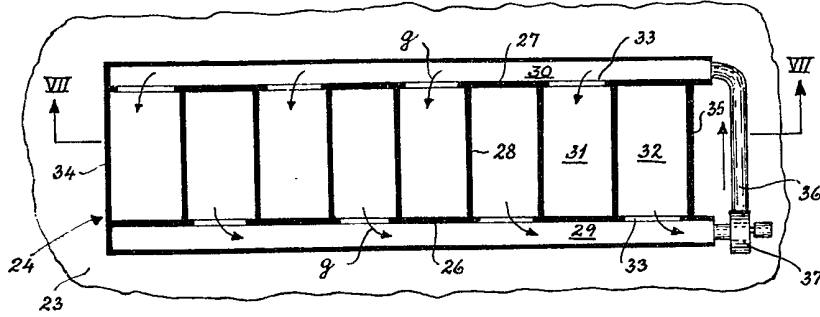

Fig. 7

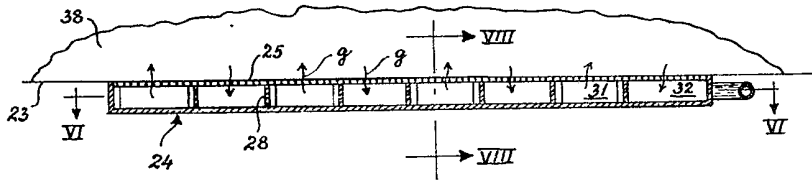

Fig. 8

