



US00D782427S

(12) **United States Design Patent**
Yeh et al.

(10) **Patent No.:** **US D782,427 S**

(45) **Date of Patent:** **** Mar. 28, 2017**

(54) **LIGHT-EMITTING DIODE ARRAY**

(71) Applicant: **EPISTAR CORPORATION**, Hsinchu (TW)

(72) Inventors: **Hui-Chun Yeh**, Hsinchu (TW);
Chien-Fu Shen, Hsinchu (TW);
Tsun-Kai Ko, Hsinchu (TW)

(73) Assignee: **EPISTAR CORPORATION**, Hsinchu (TW)

(**) Term: **15 Years**

(21) Appl. No.: **29/552,985**

(22) Filed: **Jan. 27, 2016**

(30) **Foreign Application Priority Data**

Jul. 29, 2015 (TW) 104304069

(51) **LOC (10) Cl.** **13-03**

(52) **U.S. Cl.**
USPC **D13/180**

(58) **Field of Classification Search**

USPC D13/180; D26/1
CPC ... H01L 25/167; H01L 25/0753; H01L 27/15;
H01L 27/156; H01L 33/00; H01L 33/04;
H01L 33/08; H01L 33/10; H01L 33/20;
H01L 33/38; H01L 33/42; H01L 33/48;
H01L 33/483; H01L 33/486; F21K 9/135;
F21K 9/30; F21K 9/50; Y10S 362/80

See application file for complete search history.

(56) **References Cited**

U.S. PATENT DOCUMENTS

D681,559 S * 5/2013 Shen D13/180
D681,560 S * 5/2013 Shen D13/180
D681,569 S * 5/2013 Yeh D13/180

D684,550 S * 6/2013 Yeh D13/180
8,546,840 B2 * 10/2013 Inoue H01L 33/38
257/99
D697,490 S * 1/2014 Yeh D13/180
D716,238 S * 10/2014 Yeh D13/180
D728,494 S * 5/2015 Yeh D13/180

(Continued)

Primary Examiner — Selina Sikder

(74) *Attorney, Agent, or Firm* — Muncy, Geissler, Olds & Lowe, P.C.

(57) **CLAIM**

The ornamental design for a light-emitting diode array, as shown and described.

DESCRIPTION

FIG. 1 is a perspective view of a light-emitting diode array showing our first example of the new design; FIG. 2 is another perspective view thereof; FIG. 3 is a front elevational view thereof; FIG. 4 is a rear elevational view thereof; FIG. 5 is a left side view thereof; FIG. 6 is a right side view thereof; FIG. 7 is a top plan view thereof; FIG. 8 is a bottom plan view thereof; FIG. 9 is a perspective view of a light-emitting diode array showing our second example of the new design; FIG. 10 is another perspective view thereof; FIG. 11 is a front elevational view thereof; FIG. 12 is a rear elevational view thereof; FIG. 13 is a left side view thereof; FIG. 14 is a right side view thereof; FIG. 15 is a top plan view thereof; and, FIG. 16 is a bottom plan view thereof.

The broken line showing is for the purpose of illustrating environmental structure only and forms no part of the claimed design.

1 Claim, 12 Drawing Sheets

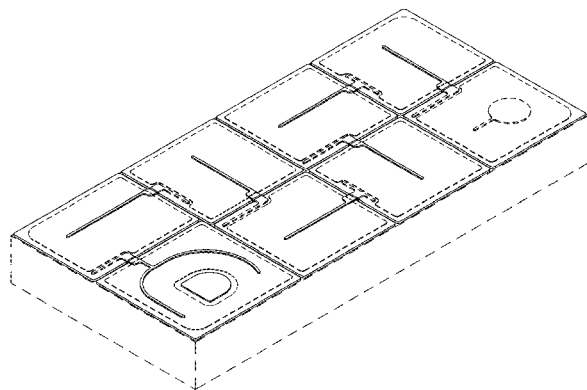
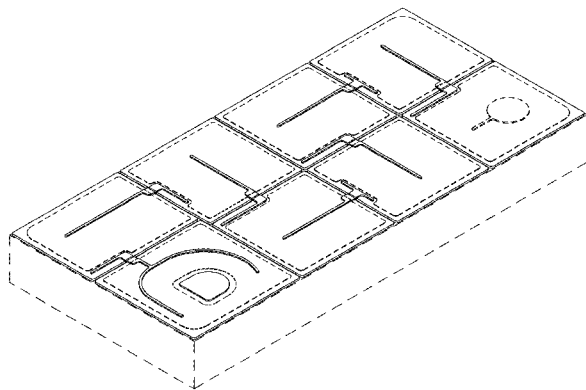

(56)

References Cited

U.S. PATENT DOCUMENTS

D748,592	S *	2/2016	Yeh	D13/180
9,373,751	B2 *	6/2016	Sato	H01L 33/36
9,472,724	B2 *	10/2016	Emura	H01L 33/38
2005/0212002	A1 *	9/2005	Sanga	H01L 33/20
					257/96
2011/0215363	A1 *	9/2011	Kimura	H01L 33/36
					257/99
2011/0272730	A1 *	11/2011	Bae	H01L 33/38
					257/99
2012/0018766	A1 *	1/2012	Emura	H01L 33/38
					257/99

* cited by examiner

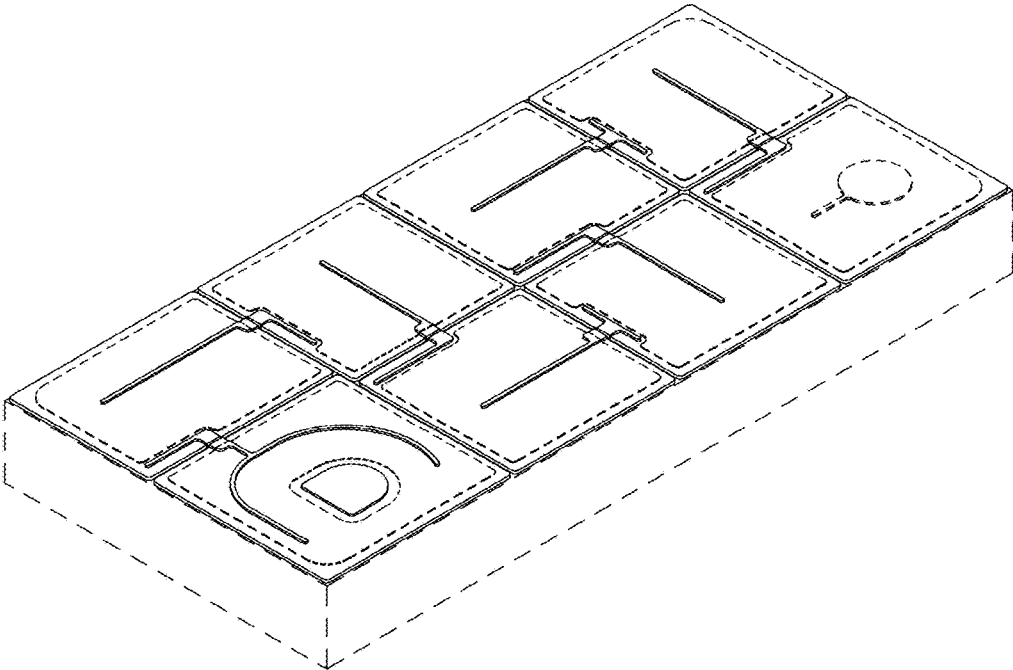

FIG. 1

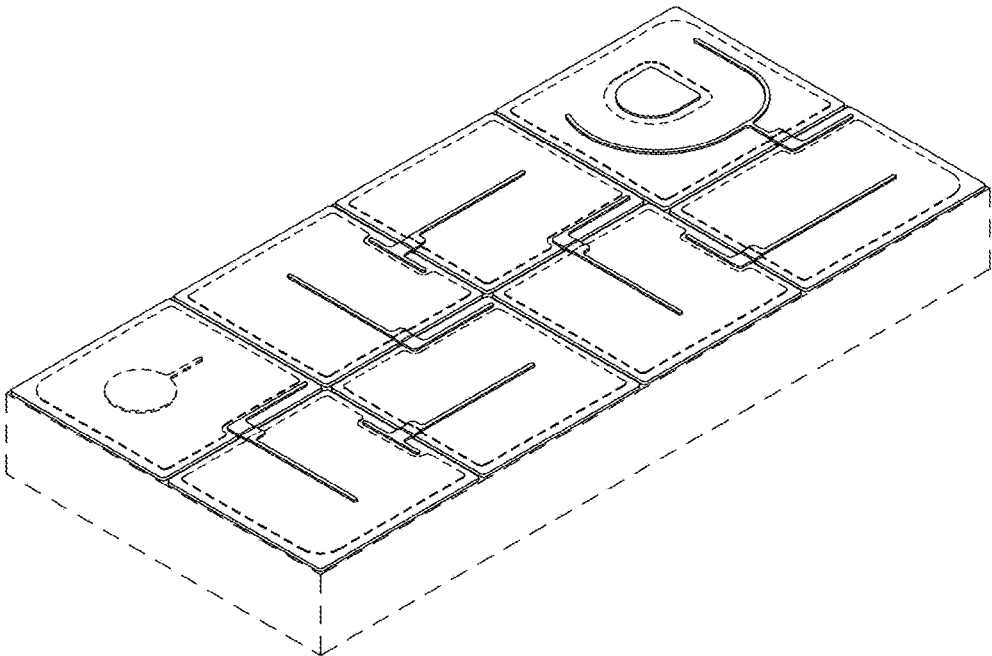

FIG. 2

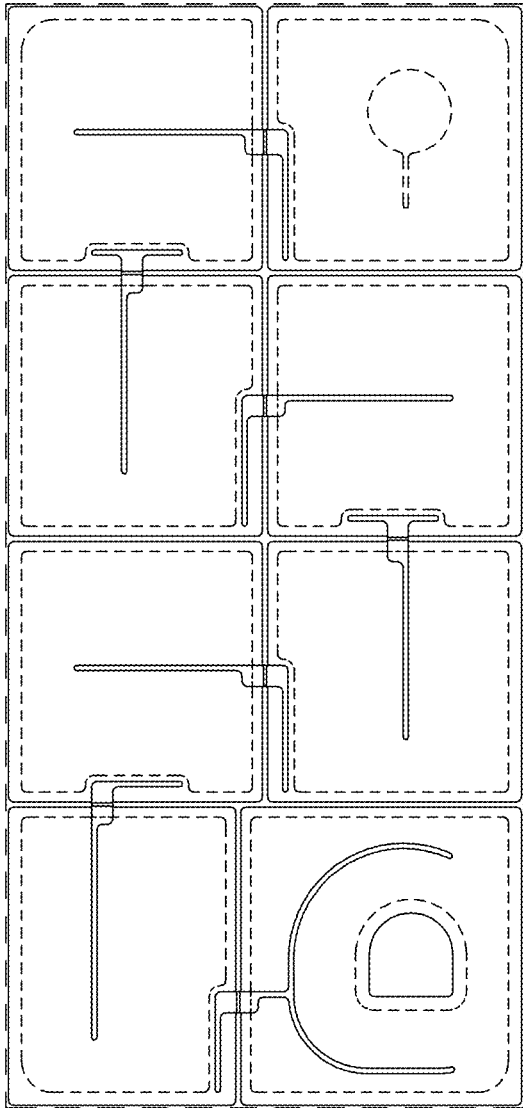

FIG. 3

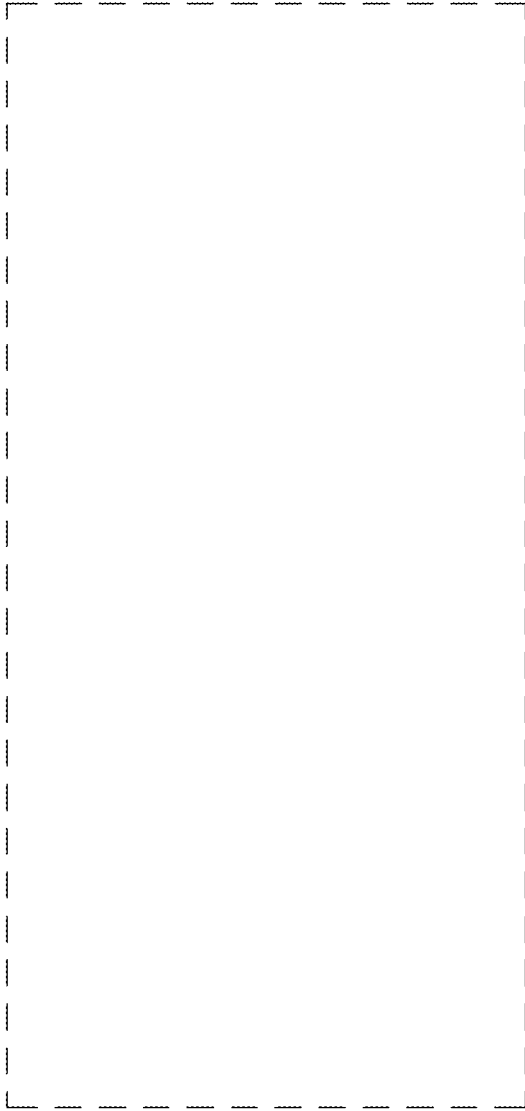

FIG. 4



FIG. 5



FIG. 6



FIG. 7



FIG. 8

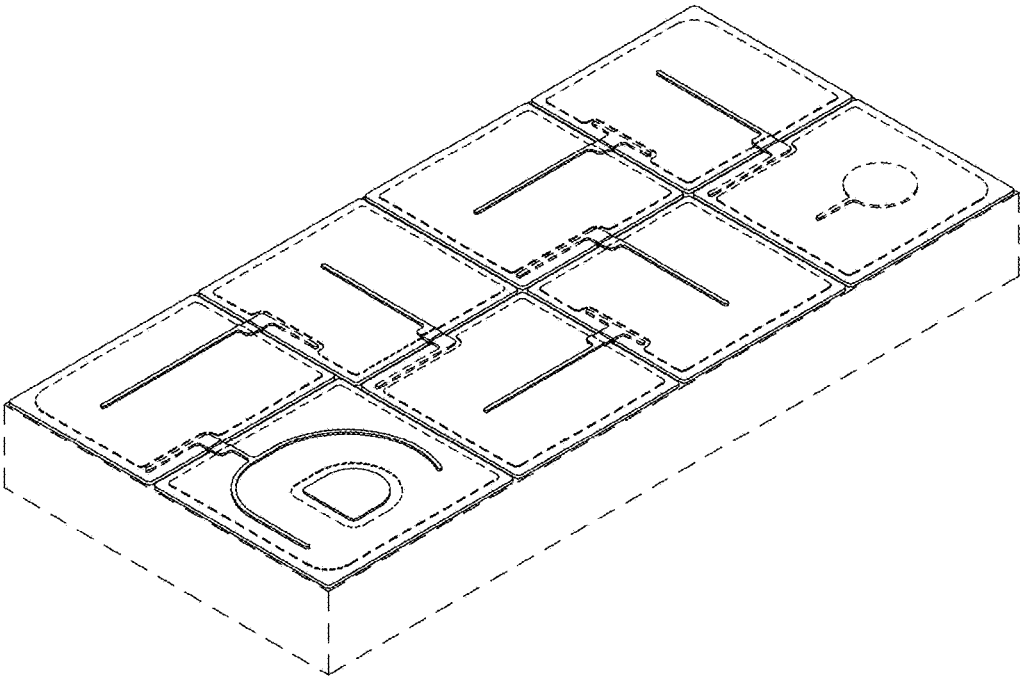

FIG. 9

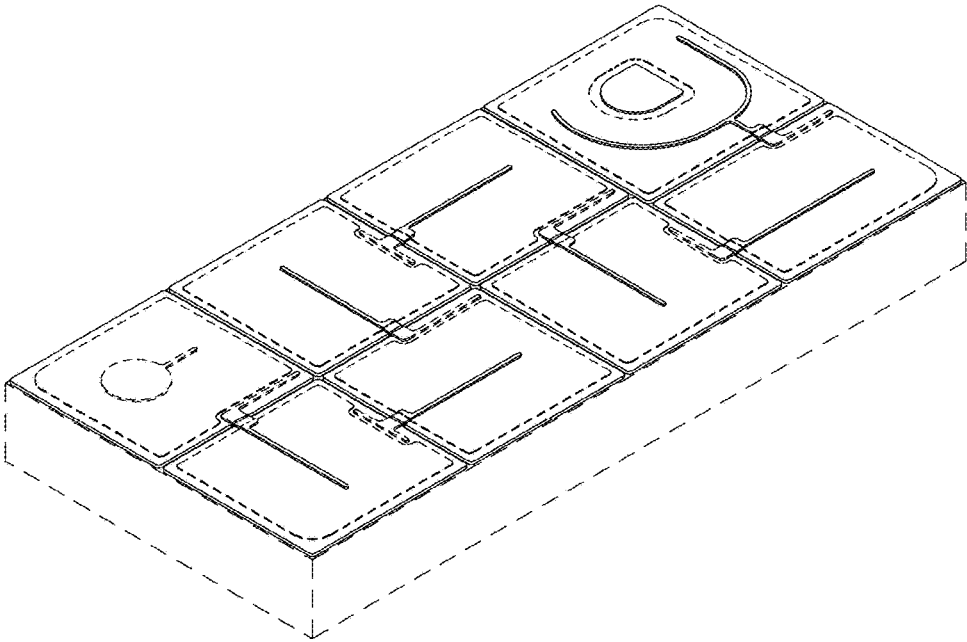

FIG. 10

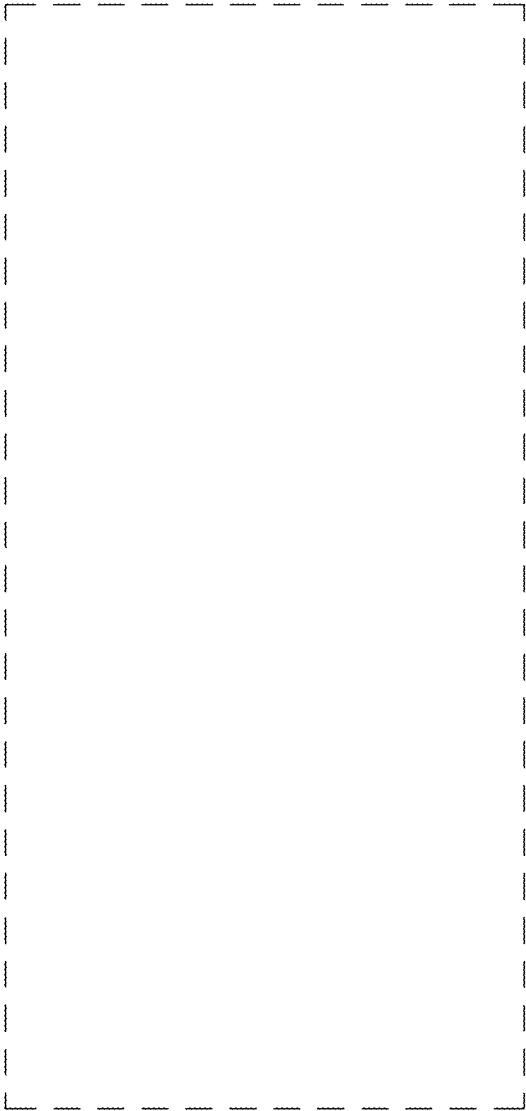

FIG. 12



FIG. 13



FIG. 14



FIG. 15

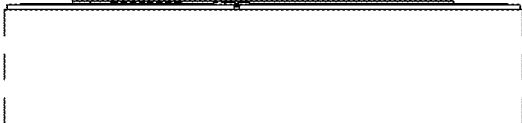

FIG. 16