



INTERNATIONAL APPLICATION PUBLISHED UNDER THE PATENT COOPERATION TREATY (PCT)

<p>(51) International Patent Classification ⁵ : A61L 9/12, F24F 3/12</p>	<p>A1</p>	<p>(11) International Publication Number: WO 94/23765 (43) International Publication Date: 27 October 1994 (27.10.94)</p>
<p>(21) International Application Number: PCT/NL94/00084 (22) International Filing Date: 20 April 1994 (20.04.94) (30) Priority Data: 93201166.1 21 April 1993 (21.04.93) EP (34) Countries for which the regional or international application was filed: AT et al. (71) Applicant (for all designated States except US): SARA LEE/DE N.V. [NL/NL]; Keulsekade 143, NL-3532 AA Utrecht (NL). (72) Inventor; and (75) Inventor/Applicant (for US only): DUTERLOO, Caroline, Gertrude [NL/NL]; Damloperwerf 1, NL-2317 DS Leiden (NL). (74) Agent: SMULDERS, Th., A., H., J.; Vereenigde Octrooibureaux, Nieuwe Parklaan 97, NL-2587 BN The Hague (NL).</p>		<p>(81) Designated States: AT, AU, BB, BG, BR, BY, CA, CH, CN, CZ, DE, DK, ES, FI, GB, GE, HU, JP, KG, KP, KR, KZ, LK, LU, LV, MD, MG, MN, MW, NL, NO, NZ, PL, PT, RO, RU, SD, SE, SI, SK, TJ, TT, UA, US, UZ, VN, European patent (AT, BE, CH, DE, DK, ES, FR, GB, GR, IE, IT, LU, MC, NL, PT, SE), OAPI patent (BF, BJ, CF, CG, CI, CM, GA, GN, ML, MR, NE, SN, TD, TG).</p> <p>Published With international search report. Before the expiration of the time limit for amending the claims and to be republished in the event of the receipt of amendments.</p>
<p>(54) Title: DEVICE FOR CONTINUOUSLY DISPENSING AN ACTIVE COMPONENT TO THE SURROUNDINGS</p>		
<p>(57) Abstract</p>		
<p>The invention relates to a device for continuously dispensing an active component to the surroundings, comprising a holder (5) for a liquid (10) containing an active component, which holder (5) is provided with means for continuously dispensing this liquid to the surroundings and means for building up pressure in the holder through osmosis, under the influence of which pressure the liquid can be dispensed to the surroundings.</p>		

FOR THE PURPOSES OF INFORMATION ONLY

Codes used to identify States party to the PCT on the front pages of pamphlets publishing international applications under the PCT.

AT	Austria	GB	United Kingdom	MR	Mauritania
AU	Australia	GE	Georgia	MW	Malawi
BB	Barbados	GN	Guinea	NE	Niger
BE	Belgium	GR	Greece	NL	Netherlands
BF	Burkina Faso	HU	Hungary	NO	Norway
BG	Bulgaria	IE	Ireland	NZ	New Zealand
BJ	Benin	IT	Italy	PL	Poland
BR	Brazil	JP	Japan	PT	Portugal
BY	Belarus	KE	Kenya	RO	Romania
CA	Canada	KG	Kyrgystan	RU	Russian Federation
CF	Central African Republic	KP	Democratic People's Republic of Korea	SD	Sudan
CG	Congo	KR	Republic of Korea	SE	Sweden
CH	Switzerland	KZ	Kazakhstan	SI	Slovenia
CI	Côte d'Ivoire	LI	Liechtenstein	SK	Slovakia
CM	Cameroon	LU	Luxembourg	SN	Senegal
CN	China	LK	Sri Lanka	TD	Chad
CS	Czechoslovakia	LV	Latvia	TG	Togo
CZ	Czech Republic	MC	Monaco	TJ	Tajikistan
DE	Germany	MD	Republic of Moldova	TT	Trinidad and Tobago
DK	Denmark	MG	Madagascar	UA	Ukraine
ES	Spain	ML	Mali	US	United States of America
FI	Finland	MN	Mongolia	UZ	Uzbekistan
FR	France			VN	Viet Nam
GA	Gabon				

Title: Device for continuously dispensing an active component to the surroundings.

The invention relates to a system with which a continuous and constant quantity of an active substance can be dispensed to the surroundings. Specifically, the invention relates to an air freshener or an insecticide vaporizer for household or industrial use. Such vaporizers can be used in different places in the home, such as the living room; placement is also possible at very specific places, such as for example under the rim of a toilet bowl.

Many kinds of air fresheners and insecticide vaporizers are known. One of the oldest systems consists of a bottle from which the active substance is absorbed into a wick and evaporated on the surface. Solid carrier materials are also known, where the active substance has been impregnated in the carrier. The active substance, which is to be found on the surface, evaporates as soon as the package is opened. The active substance then diffuses to the evaporation surface. Air freshening gels are based on the same principle. The perfume or insecticide in these products is contained in a jelly instead of a solid carrier.

Systems are also known in which the vaporization of the perfume is achieved or accelerated by heating the evaporation surface.

All of these systems have disadvantages. A serious objection is that completely uniform vaporization over time is usually not achieved. This is partly because the transport of active substance is not uniform but concentration-dependent. On the other hand, dirt or insoluble constituents of the product often precipitate on the evaporation surface so that the quantity of active substance which is dispensed per unit of time to the surroundings is decreased.

Another disadvantage is that the relative proportion of the active substances dispensed varies markedly with time if a

mixture of active substances is involved, which is often the case with an air freshener. If the active substance is a perfume, the most volatile components evaporate first, followed by the least volatile components. This causes an
5 undesirable change in scent.

Another drawback of most of the known systems is that solvents have to be used, which is undesirable from an environmental viewpoint.

The object of the invention is to provide a system which
10 does not have the above disadvantages and which provides for a constant and continuous dispensation of active substances during the whole lifetime of the product, where no scent change occurs during use and only a very limited amount of solvents is necessary, if at all.

15 Accordingly, the invention relates to a device for continuously dispensing an active component to the surroundings, comprising a holder for a liquid containing the active component mentioned, which holder is provided with means for continuously dispensing this active component to the
20 surroundings and means for building up a pressure in the holder through osmosis, under the influence of which pressure the active component can be dispensed to the surroundings.

The invention is therefore based on the principle of an osmotic pump, which means that the pressure in the holder is
25 built up by osmosis, so that the active component in the holder is brought continuously and uniformly to the means for the dispensation of these components to the surroundings, and specifically to an evaporation surface where the active component can be continuously and uniformly dispensed to the
30 surroundings.

In order for the osmotic pressure to be built up, it is important that the holder is provided with a semi-permeable membrane which can stand in contact with a liquid on both sides, and where the liquid on the inside of the holder should
35 have a higher concentration of dissolved substances than the liquid on the outside of the holder. The liquid, in general water, will diffuse in through the semi-permeable membrane by

osmotic action (osmosis), so that pressure is built up in the holder, under the influence of which pressure the active component will be transported to the means for dispensation to the surroundings.

5 In its simplest form the device according to the invention can consist of a holder comprising some sort of means for the dispensation of an active component, such as an evaporation surface and a semi-permeable membrane, which holder is otherwise closed. This membrane will preferably be
10 located at the bottom of the holder, whilst the evaporation surface is located at the top. The holder is filled with two, preferably immiscible, liquids. One liquid, which preferably has the highest specific gravity, consists of an aqueous solution, whilst the other liquid is the liquid active
15 component itself or a solution thereof in a liquid. If the liquid active component, or its solution, is water-immiscible and has a lower density than water, the holder can consist of a single chamber. In that case, due to the difference in density, the active component will always be at the top of the
20 holder, near the evaporation surface, so that the active substance will be moved outward as the osmotic pressure in the holder is built up. Only when the holder no longer contains any active component will water come onto the evaporation surface. In such a case it can be advantageous to add a dye to
25 the water, so that it immediately becomes clear that the device no longer contains any active component.

Of course, with this simplest embodiment of the invention, it is necessary that a liquid is provided on the other side of the semi-permeable membrane, that has a lower
30 concentration of dissolved substances, so that it can act as a medium for building up the pressure. In the simplest case this can be ordinary water, for example tap water, distilled water or demineralised water. In a simple embodiment of the invention the above holder can be simply placed in a basin of
35 water, or provided at the bottom with a second chamber, which can be filled with water from the outside.

In the case described above, a system is assumed in which there are two immiscible liquids in the holder. However, if liquids are used which are wholly or partly miscible, then it is preferable to separate the liquids in the holder, e.g. by a piston or a foil. If a piston is used it is still possible to use two different chambers. In one chamber, the pressure can be built up and transmitted via a piston rod or other connection to a piston provided in a second chamber. This two-chamber system need not be solely reserved for liquids which are wholly or partly miscible. It can also be desirable to separate the liquids if the device is used in places where it is regularly subjected to movement, such as bumps or shaking, so as to prevent the liquid which is responsible for building up the osmotic pressure from emerging via the evaporation surface at undesirable moments.

The device according to the invention can be made up of a number of separate components, such as a first holder which has been described above, and a separate second holder, inside which the first holder with the active component can be placed. This has the particular advantage that the system can be made with a disposable holder for the active component, whilst the second holder only needs to be purchased once and can be reused with a refill to be purchased separately. It is of course also possible to make the system as a complete whole which cannot be taken apart.

As will be clear from the elucidation given above, the invention is based on the principle of an osmotic pump. In the holder, on the inner side of a membrane, a preferably saturated solution is provided. As soon as the other side of the membrane is brought into contact with water or an aqueous solution with a lower concentration of dissolved substance, such as electrolyte, water will be transported through the semi-permeable membrane from the outside reservoir to the inside reservoir. This causes the active substance in the holder to be forced towards the means for dispensing the active substance to the surroundings, where it is then dispensed to the surroundings.

The means referred to generally contain either an evaporation surface which is fed directly from the holder, or one or more openings in the holder, which openings may optionally be provided with a permeable partition, whence the active component is fed to a separate evaporation surface, such as a collector basin or a porous material.

In their simplest form these means therefore comprise a simple provision of the holder, where the released liquid containing the dissolved active component, or the active component itself, is collected and evaporated. The condition is that the size of the evaporation surface is chosen so that the quantity of evaporated liquid is larger than or equal to the amount of liquid fed to it. Adjuvants can be used to accelerate the evaporation so that a limited evaporation surface will suffice. This will make it possible to achieve a large evaporation from a relatively small area. The evaporation surface can be increased appreciably by using paper. Sintered metals also produce this effect, as do natural and synthetic materials. The most commonly used methods for increasing the evaporation rate are heating the evaporation surface and increasing the air circulation by arranging a ventilator near this evaporation surface.

In a preferred embodiment, the liquid on the inside of the semi-permeable membrane consists of water having an electrolyte dissolved therein. An advantage of the use of water is that it can be obtained virtually everywhere and can be used without problems. Electrolytes are preferred as the dissolved substance, and preferably easily obtainable, harmless substances such as sodium chloride. It is possible, however, to use any substance where a pressure can be built up by osmosis. Accordingly, sugars are also suitable, as are salts such as magnesium sulphate and borax.

Because, during use, liquid is added to the osmotic liquid via the semi-permeable membrane, dilution occurs, so that the salt concentration falls and the dispensation of the upper liquid to the evaporation element would be reduced. To obviate this drawback, the lower liquid will preferably be a

supersaturated solution. It is preferred to add an excess of substance to be dissolved, which may be provided at the bottom of the inside holder. This layer of substance to be dissolved will ensure that a saturated solution as is always present as osmotic liquid during the lifetime of the device, and that there will therefore be a continuous and constant transport of the outside liquid via the semi-permeable membrane to the inner holder.

To activate the osmotic pump, the outer holder, which surrounds a reservoir, must be filled by the user with a liquid which has a lower concentration of electrolyte than the lower liquid in the inner holder. Tap water is the most obvious choice. The holder is provided with special filling openings for this purpose. If the holder is to be fitted under the rim of a toilet bowl these openings must be chosen so that the outer reservoir is filled during the first flush.

The semi-permeable membrane can be any membrane which is permeable to the chosen liquid and impermeable to the chosen electrolyte. Suitable membranes, such as ceramic and plastic membranes, are commercially available.

In order to determine if the vaporizer has reached the end of its lifetime, it may be advantageous to include an "end of lifetime" indicator in the system. An example of this is the selective coloration of the lower, osmotic liquid. As soon as the evaporation surface acquires this colour, it can be assumed that the vaporizer is spent.

The products according to the invention are very suitable for use as air fresheners for household use. They can also be used as vaporizers for insecticides. A specific application is their use as a toilet cleaner and air freshener. The active substances can then consist of non-volatile substances which are dissolved in the flushing water as the toilet is flushed. These are typically cleaning and disinfecting agents. Volatile components are also included as active substances which are active for some time as an air freshener. The duration of the activity of the substance after each flush is determined by the volume of the outer holder, in which a part of the

flushing water is collected and by the residence time of the flushing water in the holder, which can be regulated by attaching an outflow opening in the outer holder.

The invention will now be explained with reference to the drawing. This shows an example of a device according to the invention.

The holder consists of an outer holder (5), provided with a filling opening (11) and an inner holder (1), filled with liquid (10). Provided in the inner holder (1) are two liquids. The upper liquid (2) contains the active ingredients. The lower liquid (4), which contains undissolved electrolyte (9) or another osmotic substance, ensures that a continuous quantity of the upper liquid (2) is delivered to an evaporation element (6) for a prolonged time.

The upper liquid (2) may exclusively consist of one or more active ingredients. Active ingredients are perfumes, odour absorbers, odour modifying agents, substances which influence odour, insecticides, insect repellents and insect attractants, substances which clear the respiratory passages, and the like. Adjuvants may also be added, such as solvents, evaporation inhibitors or accelerators, carriers, specific gravity regulators, thickening agents, fillers and the like.

The lower liquid (4) is separated from the upper liquid by an interface (3). This interface can be simply achieved by selecting two immiscible liquids. Preferably, hydrophobic liquids are used for the upper liquid (2) and hydrophilic liquids for the lower liquid (4).

The interface is then obtained automatically. Preferred is a formulation wherein the upper liquid is an oil (perfume oil) and the lower liquid is water.

The interface (3) can also be realized in some other way, for example via a wax layer, a polymeric foil or a simple partition of plastics or other materials.

A separation between the upper and lower liquid is a requisite if the two liquids are miscible or if one or more of the active components is soluble in the lower liquid.

The lower liquid (4) ensures a uniform and continuous delivery of the upper liquid to the evaporation element (5). This aim is achieved by choosing an osmotically working solution for the lower liquid, for which purpose the inner
5 holder is separated from a liquid in the outer holder (5) by a semi-permeable membrane (7).

Thus, an osmotic pump is formed, whereby liquid is added continuously and uniformly from the outer holder to the lower liquid via the semi-permeable membrane. The interface is
10 displaced upwards because of the increase in volume of the lower liquid, and as a result the upper liquid (2) is transported to the evaporation surface (6) via the openings (8) which have been provided.

CLAIMS

1. A device for continuously dispensing an active component to the surroundings, comprising a holder for a liquid containing an active component, which holder is provided with means for continuously dispensing this liquid to the surroundings and means for building up a pressure in the holder through osmosis, under the influence of which pressure the liquid can be dispensed to the surroundings.
2. A device according to claim 1, wherein the means for building up pressure in the holder comprise a semi-permeable membrane which forms a separation between two liquids which can build up pressure through osmosis.
3. A device according to claim 2, wherein the liquids which can build up pressure through osmosis at least consist of a liquid having one or more components dissolved therein which can exert an osmotic action, said liquid being situated on the inside of the membrane and on the other hand of a liquid in which none or less of the above components are dissolved.
4. A device according to claims 1-3, wherein as a first liquid a saturated salt solution is used.
5. A device according to claim 4, wherein on the inner side of the membrane an amount of non-dissolved salt is present in the saturated salt solution, such that the solution remains saturated during the lifetime of the device.
6. A device according to claims 1-5, wherein the means for dispensing the liquid to the surroundings consist of an evaporation surface.
7. A device according to claims 1-6, wherein the evaporation of the liquid is partly effected by heating and/or ventilation.
8. A device according to claims 1-7, wherein the active component has been chosen from the group consisting of perfume, insecticide, insect repellent substances, odour destroyers or combinations of two or more of these products.

9. A device according to claims 1-8, wherein the active component is dispensed as such to the surroundings or in the form of a solution in a low boiling organic solvent.

10. A device according to claims 1-9, comprising a first
5 holder provided with means for continuously dispensing the liquid to the surroundings and means for building up pressure in the holder through osmosis, as well as a second holder which at least partly surrounds the first holder and which is provided with a chamber in which a liquid can be introduced
10 which comes into contact with the means for building up pressure in the holder through osmosis.

11. A device according to claims 1-10, wherein water as well as an aqueous solution are used as liquids for building up pressure through osmosis.

15 12. A device according to claim 11, wherein the aqueous solution consists of a solution of a salt, such as sodium chloride, magnesium sulfate or borax, or a non-electrolyte, such as sugar.

20 13. A device according to claims 1-12, wherein the liquid which contains the active component is immiscible with the liquid which builds up pressure through osmosis.

25 14. A device according to claim 13, wherein a movable partition is present between the liquid containing the active component and the liquid which builds up pressure through osmosis.

15. A device according to claims 1-14, wherein means are present which indicate visually or otherwise if the device has no or substantially no active component left.

30 16. A holder for continuously dispensing an active component to the surroundings, filled with a liquid containing an active component, and provided with means for continuously dispensing this active component to the surroundings and with means for building up a pressure in the holder through osmosis, suitable for use in the device according to claims 1-15.

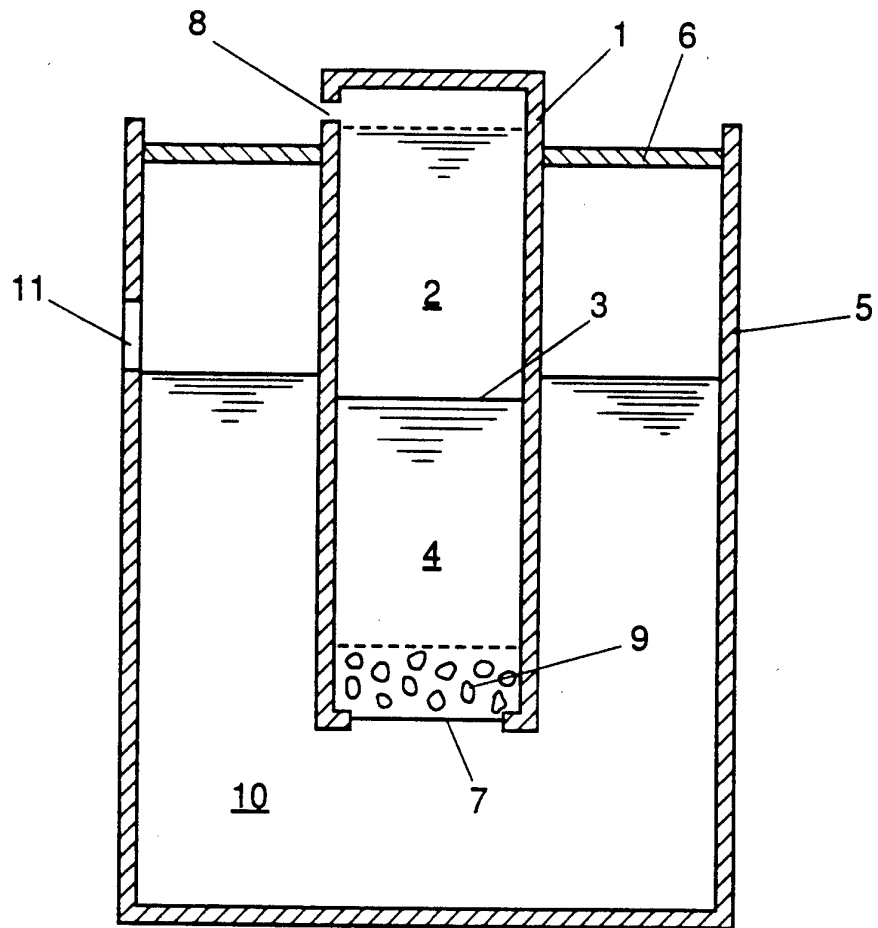

INTERNATIONAL SEARCH REPORT

International application No.
PCT/NL 94/00084

A. CLASSIFICATION OF SUBJECT MATTER
IPC 5 A61L9/12 F24F3/12

According to International Patent Classification (IPC) or to both national classification and IPC

B. FIELDS SEARCHED

Minimum documentation searched (classification system followed by classification symbols)
IPC 5 A61L F24F A61M

Documentation searched other than minimum documentation to the extent that such documents are included in the fields searched

Electronic data base consulted during the international search (name of data base and, where practical, search terms used)

C. DOCUMENTS CONSIDERED TO BE RELEVANT

Category *	Citation of document, with indication, where appropriate, of the relevant passages	Relevant to claim No.
A	CH,A,441 863 (CIBA) 15 January 1968 see claim 1	1
A	US,A,3 587 968 (HENNART) 28 June 1971 see abstract; figures 7,10	1

Further documents are listed in the continuation of box C.

Patent family members are listed in annex.

* Special categories of cited documents :

- "A" document defining the general state of the art which is not considered to be of particular relevance
- "E" earlier document but published on or after the international filing date
- "L" document which may throw doubts on priority claim(s) or which is cited to establish the publication date of another citation or other special reason (as specified)
- "O" document referring to an oral disclosure, use, exhibition or other means
- "P" document published prior to the international filing date but later than the priority date claimed

- "T" later document published after the international filing date or priority date and not in conflict with the application but cited to understand the principle or theory underlying the invention
- "X" document of particular relevance; the claimed invention cannot be considered novel or cannot be considered to involve an inventive step when the document is taken alone
- "Y" document of particular relevance; the claimed invention cannot be considered to involve an inventive step when the document is combined with one or more other such documents, such combination being obvious to a person skilled in the art.
- "&" document member of the same patent family

Date of the actual completion of the international search

18 August 1994

Date of mailing of the international search report

22. 08. 94

Name and mailing address of the ISA

European Patent Office, P.B. 5818 Patentlaan 2
NL - 2280 HV Rijswijk
Tel. (+ 31-70) 340-2040, Tx. 31 651 epo nl,
Fax: (+ 31-70) 340-3016

Authorized officer

Peschel, G

INTERNATIONAL SEARCH REPORT

information on patent family members

International application No.
PCT/NL 94/00084

Patent document cited in search report	Publication date	Patent family member(s)	Publication date
CH-A-441863		GB-A- 1074957	
US-A-3587968	28-06-71	NONE	