

(19) World Intellectual Property Organization  
International Bureau



(43) International Publication Date  
6 August 2009 (06.08.2009)

PCT

(10) International Publication Number  
**WO 2009/097583 A1**

(51) International Patent Classification:  
A61F 2/84 (2006.01)

(74) Agent: WICKHEM, Scot, J.; Crompton, Seager & Tufte, LLC, 1221 Nicollet Avenue, Suite 800, Minneapolis, Minnesota 55403 (US).

(21) International Application Number:  
PCT/US2009/032738

(81) Designated States (unless otherwise indicated, for every kind of national protection available): AE, AG, AL, AM, AO, AT, AU, AZ, BA, BB, BG, BH, BR, BW, BY, BZ, CA, CH, CN, CO, CR, CU, CZ, DE, DK, DM, DO, DZ, EC, EE, EG, ES, FI, GB, GD, GE, GH, GM, GT, HN, HR, HU, ID, IL, IN, IS, JP, KE, KG, KM, KN, KP, KR, KZ, LA, LC, LK, LR, LS, LT, LU, LY, MA, MD, ME, MG, MK, MN, MW, MX, MY, MZ, NA, NG, NI, NO, NZ, OM, PG, PH, PL, PT, RO, RS, RU, SC, SD, SE, SG, SK, SL, SM, ST, SV, SY, TJ, TM, TN, TR, TT, TZ, UA, UG, US, UZ, VC, VN, ZA, ZM, ZW.

(22) International Filing Date: 30 January 2009 (30.01.2009)

(25) Filing Language: English

(26) Publication Language: English

(30) Priority Data:  
12/022,513 30 January 2008 (30.01.2008) US

(71) Applicant (for all designated States except US): BOSTON SCIENTIFIC SCIMED, INC. [US/US]; One Scimed Place, Maple Grove, Minnesota 55311 (US).

(84) Designated States (unless otherwise indicated, for every kind of regional protection available): ARIPO (BW, GH, GM, KE, LS, MW, MZ, NA, SD, SL, SZ, TZ, UG, ZM, ZW), Eurasian (AM, AZ, BY, KG, KZ, MD, RU, TJ, TM), European (AT, BE, BG, CH, CY, CZ, DE, DK, EE, ES, FI, FR, GB, GR, HR, HU, IE, IS, IT, LT, LU, LV, MC, MK, MT, NL, NO, PL, PT, RO, SE, SI, SK, TR), OAPI (BF, BJ, CF, CG, CI, CM, GA, GN, GQ, GW, ML, MR, NE, SN, TD, TG).

(72) Inventors; and

(75) Inventors/Applicants (for US only): GERDTS, Michael [US/US]; 17073 232 Avenue NW, Big Lake, Minnesota 55309 (US). MOBERG, John, R. [US/US]; 12477 194th Lane NW, Elk River, Minnesota 55330 (US). FORD, James, J. [US/US]; 389 E. Mainzer Street, West Saint Paul, Minnesota 55118 (US). DITTER, Theresa [US/US]; 1410 Willow Creek Lane, Shoreview, Minnesota 55126 (US).

Published:  
— with international search report

(54) Title: MEDICAL SYSTEMS AND RELATED METHODS

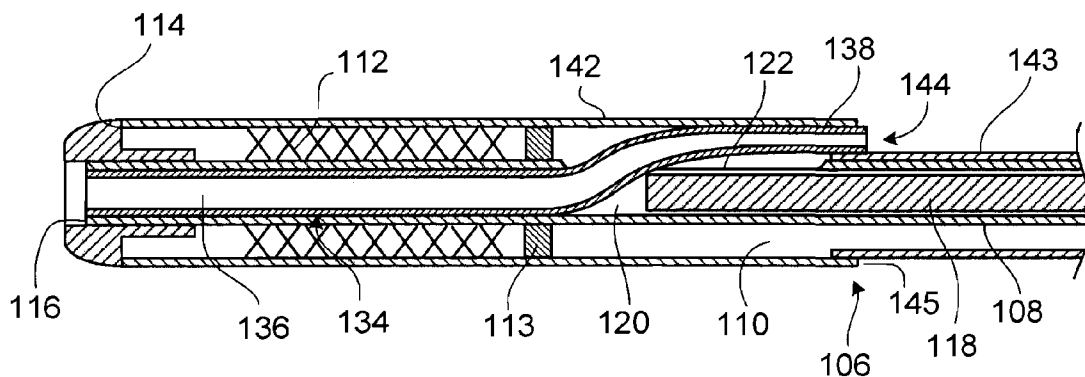

FIG. 2

(57) Abstract: Medical systems and related methods are disclosed. In some embodiments, the medical systems include an inner tubular member defining an aperture and an outer tubular member at least partially surrounding the inner tubular member. The inner and outer tubular members can be arranged such that an implantable medical endoprosthesis can be disposed therebetween.

WO 2009/097583 A1

## Medical Systems and Related Methods

### TECHNICAL FIELD

This invention relates to medical systems and related methods.

5

### BACKGROUND

Devices are known for delivering implantable endoprotheses, such as stents, into a body vessel. Devices of this kind often include a proximal portion that remains external to the body vessel during use and a distal portion that is inserted into the body vessel (e.g., through an incision). The proximal portion typically provides for manipulation of the device during use. The distal portion often includes an outer member slidably positioned about an inner tubular member with an endoprosthesis disposed therebetween. Generally, the distal portion of the device is advanced through the body vessel to a treatment site (e.g., a stenosis or aneurysm). The outer member can then be retracted to allow the endoprosthesis to expand to engage a wall of the body vessel at the treatment site. Thereafter, the device is removed leaving the endoprosthesis engaged with the body vessel.

10

15

### SUMMARY

In one aspect of the invention, a system includes an outer tubular member defining a lumen, an inner tubular member extending within the lumen of the outer tubular member, and a support member disposed in a lumen of the inner tubular member. The inner tubular member has a sidewall defining an aperture configured to allow a guide wire to pass therethrough. The inner and outer tubular members are configured so that an implantable medical endoprosthesis can be disposed between the inner and outer tubular members. The support member is configured such that at least a portion of the support member can be disposed adjacent the aperture, and the support member and the outer tubular member are configured to retract relative to the inner tubular member.

20

25

In another aspect of the invention, a system includes an inner tubular member having a sidewall defining an elongate slot and an outer tubular member at least partially surrounding the inner tubular member. The inner tubular member is formed of one or more metals. The outer tubular member has a sidewall at least partially

30

defining an opening arranged such that a guide wire can be passed through the elongate slot of the inner tubular member and the opening of the outer tubular member. The inner tubular member and the outer tubular member are arranged such that an implantable medical endoprosthesis can be disposed between the inner tubular member and the outer tubular member.

In an additional aspect of the invention, a system includes an inner tubular member extending within a lumen of an outer tubular member and a support member disposed in a lumen of the inner tubular member. The inner tubular member has a sidewall defining an aperture configured to allow a guide wire to pass through the aperture. The support member is configured so that at least a portion of the support member can be adjacent to the aperture. The support member and the outer tubular member are configured to retract relative to the inner tubular member.

In another aspect of the invention, a system includes an inner tubular member extending within a lumen of an outer tubular member from a proximal end of the outer tubular member toward a distal end of the outer tubular member. The inner tubular member is of unitary construction and has a sidewall defining an aperture configured to allow a guide wire to pass through the aperture. The outer tubular member and the inner tubular member are configured so that an implantable medical endoprosthesis can be disposed between the outer tubular member and the inner tubular member. The outer tubular member is retractable relative to the inner tubular member.

Embodiments can include one or more of the following features.

In some embodiments, the elongate slot extends longitudinally along the inner tubular member.

In certain embodiments, the elongate slot has a length greater than or equal to a length of an implantable medical endoprosthesis disposed between the outer tubular member and the inner tubular member distal to the elongate slot.

In some embodiments, the inner tubular member is of unitary construction.

In certain embodiments, the inner tubular member extends within a lumen of the outer tubular member from a proximal end of the outer tubular member toward a distal end of the outer tubular member.

In some embodiments, the inner tubular member is formed of the one or more metals.

In certain embodiments, a portion of the sidewall of the inner tubular member

proximal to the elongate slot defines cuts.

In some embodiments, the cuts are in the form of an interrupted spiral.

In certain embodiments, a portion of the sidewall of the inner tubular member distal to the elongate slot defines at least one cut.

5 In some embodiments, at least one cut is in the form of a continuous spiral.

In certain embodiments, a distal cross-sectional area of the inner tubular member is greater than a proximal cross-sectional area of the inner tubular member.

In some embodiments, the system further includes a support member disposed in a lumen of the inner tubular member. The support member is configured so that at least a portion of the support member can be disposed adjacent the aperture. The support member is arranged to retract relative to the inner tubular member.

In certain embodiments, a distal end portion of the support member is configured to (e.g., shaped to) direct a guide wire toward the aperture when the guide wire is passed through a lumen of the inner tubular member in a proximal direction.

15 In some embodiments, the distal end portion of the support member is tapered.

In certain embodiments, the support member is longitudinally fixed relative to the outer tubular member.

In some embodiments, a distal end portion of the support member is fixed relative to the outer tubular member at a location adjacent the opening in the sidewall of the outer tubular member.

In certain embodiments, the support member includes a distal member secured to a pull wire.

In some embodiments, the support member is substantially rotationally fixed relative to the inner tubular member.

25 In certain embodiments, at least a portion of the support member has a non-circular cross-section and at least a portion of a lumen of the inner tubular member has a non-circular cross-section.

In some embodiments, at least a portion of the support member has a square cross-section and at least a portion of a lumen of the inner tubular member has a square cross-section.

In certain embodiments, the support member includes a radial projection configured to be received in a longitudinal channel defined by the inner tubular member.

In some embodiments, the system further includes a sleeve extending within a

distal portion of the inner tubular member. The sleeve is configured to allow a guide wire to be passed through the sleeve.

In certain embodiments, the sleeve includes a polymer.

In some embodiments, the sleeve includes a polyimide.

5 In some embodiments, the sleeve is arranged to direct a guide wire into the aperture when the guide wire is passed through the sleeve in a proximal direction.

In certain embodiments, the sleeve includes a proximal portion (e.g., a proximal curved portion) that extends into the aperture.

10 In some embodiments, the system further includes an implantable medical endoprosthesis disposed between the inner tubular member and the outer tubular member.

In certain embodiments, the implantable medical endoprosthesis is a self-expanding implantable medical endoprosthesis.

15 In some embodiments, the implantable medical endoprosthesis is disposed distal to the elongate slot.

In certain embodiments, the aperture is a longitudinally extending elongate slot.

In some embodiments, the implantable medical endoprosthesis is disposed distal to the aperture.

20 Embodiments can include one or more of the following advantages.

In some embodiments, the elongate slot of the inner tubular member is configured so that a guide wire can extend radially through the elongate slot and through an opening in the outer sheath during use. The elongate slot can permit the outer tubular assembly to be retracted relative to the inner tubular member and the guide wire without substantial resistance. For example, the elongate slot can be arranged to inhibit the guide wire extending therethrough from getting pinched between the outer tubular assembly and the inner tubular member as the outer tubular member is retracted relative to the inner tubular member.

25 In certain embodiments, the inner tubular member is a continuous member of unitary construction. As a result, the inner tubular member can be manufactured relatively simply and inexpensively.

In some embodiments, the support member is disposed within the inner tubular member adjacent the elongate slot in the inner tubular member. The support member can thus support the portion of the inner tubular member including the elongate slot

and inhibit that portion of the outer tubular member from kinking.

In certain embodiments, the support member is arranged to be retracted along with the outer sheath of the outer tubular assembly to allow the location at which the guide wire passes radially through the slot to move proximally as the outer sheath is proximally retracted. The retracting support member can inhibit the guide wire from becoming pinched between the outer sheath of the outer tubular assembly and the support member as the outer sheath is retracted. This arrangement can thus help to ensure that the outer sheath can be retracted sufficiently to fully deploy the endoprosthesis.

In some embodiments, the flexibility of the inner tubular member gradually increases (i.e., does not change abruptly) in the distal direction. As a result, the inner tubular member can exhibit improved distal pushability. For example, the inner tubular member can be less prone to hinging and prolapsing as it is navigated through a vessel.

In certain embodiments, the inner tubular member includes one or more portions with material removed from the inner tubular member. The inner tubular member can, for example, include proximal and distal portions with one or more apertures (e.g., a pattern of apertures). The apertures can be arranged to provide the proximal portion of the inner tubular member with a relatively high compressive strength and the distal portion of the inner tubular member with a relatively high level of flexibility. This arrangement can improve the ability of the system to be navigated through tortuous body vessels.

Other features and advantages are in the description, drawings, and claims.

## DESCRIPTION OF DRAWINGS

Figure 1 is a broken, side view of a self-expanding stent delivery system.

Figure 2 is a cross-sectional view of a distal region of the self-expanding stent delivery system of Figure 1, taken along line 2-2 in Figure 1.

Figure 3 is a perspective view of the inner tubular member of Figure 2.

Figure 4 illustrates a connection between the inner tubular member of the catheter assembly and the housing of the handle assembly of the self-expanding stent delivery system of Figure 1.

Figure 5 is a side view of the handle assembly of the self-expanding stent delivery system of Figure 1 in an operative configuration with the near side of its

housing removed to expose certain interior components of the handle assembly.

Figure 6 is a cross-sectional view of the handle assembly of the self-expanding stent delivery system of Figure 5 in a fully assembled configuration, taken along line 6-6 in Figure 5.

5            Figures 7A-7D illustrate a method of using the self-expanding stent delivery system of Figure 1 to implant a self-expanding stent within a blood vessel.

Figure 8 is a cross-sectional view of a catheter assembly of a self-expanding stent delivery system including a support member with a distal ramped portion.

10            Figure 9 is a perspective view of an inner tubular member having a lumen with a rectangular cross-section and a support member having a rectangular cross-section disposed in the lumen.

Figure 10 is a cross-sectional view of a unitary outer sheath that has a guide wire exit port extending through its side wall.

15            Figure 11 is a perspective view of a support member that includes a support portion attached to a pull wire.

### DETAILED DESCRIPTION

Referring to Figures 1 and 2, a stent delivery system 100 includes a catheter assembly 102 and a handle assembly 104. Catheter assembly 102 includes an outer tubular assembly 106 and an inner tubular member 108 extending through a lumen 110 formed by outer tubular assembly 106. A support member 118 extends along an inner lumen 120 formed by inner tubular member 108. A self-expanding stent 112 is disposed between outer tubular assembly 106 and inner tubular member 108, near distal ends 114, 116 of outer tubular assembly 106 and inner tubular member 108. A bumper 113 extends radially from inner tubular member 108 slightly proximal to stent 112. During use, as described in more detail below, a distal portion of catheter assembly 102 can be disposed within a body vessel (e.g., a blood vessel) of a patient, and outer tubular assembly 106 and support member 118 can be moved proximally relative to inner tubular member 108 to deploy stent 112 within the body vessel.

30            Figure 3 illustrates a perspective view of inner tubular member 108. Inner tubular member 108 is of unitary construction and is formed of stainless steel. Inner tubular member 108 includes inner lumen 120, which has a substantially circular cross-section along the longitudinal axis of inner tubular member 108. An elongate slot 122 is formed in the sidewall of inner tubular member 108. Elongate slot 122 has

a width  $W_1$  that is at least large enough to allow a guide wire 124 to pass therethrough. Width  $W_1$  can, for example, be about 0.4 millimeters or greater (e.g., about 0.5 millimeters or greater). In certain embodiments, Width  $W_1$  is about 0.4 millimeters to about 1.0 millimeter (e.g., about 0.6 millimeters to about 0.8 millimeters). Elongate slot 122 extends generally parallel to the longitudinal axis of inner tubular member 108. As will be described in further detail below, the length of elongate slot 122 is typically greater than or equal to a longitudinal dimension of stent 112. In some embodiments, slot 122 has a length of about 20 millimeters or more (e.g., about 60 millimeters or more). In certain embodiments, slot 122 has a length of about 20 millimeters to about 310 millimeters (e.g., about 30 millimeters to about 300 millimeters).

The distal end of elongate slot 122 can be spaced from distal end 116 of inner tubular member 108 by about 30 millimeters or more (e.g., about 70 millimeters or more). In certain embodiments, the distal end of elongate slot 112 is spaced from distal end 116 of inner tubular member 108 by about 30 millimeters to about 320 millimeters (e.g., about 40 millimeters to about 310 millimeters).

Material can be removed from a substantial portion of the circumference of inner tubular member 108 to form elongate slot 122. In some embodiments, for example, material is removed from about 30 percent or more (e.g., about 40 percent or more, about 50 percent or more, about 60 percent or more) of the circumference of inner tubular member 108 to form elongate slot 122. In certain embodiments, material is removed from about 40 percent to about 60 percent (e.g., about 50 percent) of the circumference of inner tubular member 108 to form elongate slot 122.

Elongate slot 122 can be formed in inner tubular member 108 using any of various material removal techniques. In certain embodiments, for example, the sidewall of inner tubular member 108 is skived to form elongate slot 122. In such embodiments, elongate slot 122 can have a longitudinal cross-section substantially formed in the shape of a trough. Elongate slot 122 can alternatively or additionally be formed by using laser machining to remove material from inner tubular member 108 such that inner lumen 120 becomes exposed. In addition or in the alternative, elongate slot 122 can be formed using wire electrical discharge machining (EDM).

Inner tubular member 108 further includes a first portion 126 proximal to elongate slot 122 and a second portion 128 distal to elongate slot 122. First portion 126 includes multiple apertures (e.g., slits or cuts) 130 that extend through the sidewall



of inner tubular member 108. Apertures 130 are arranged in the form of an interrupted spiral. As a result, apertures 130 increase the flexibility of inner tubular member 108 along first portion 126 while allowing first portion 126 to remain pushable in the distal direction. For example, those regions of first portion from which material has been removed provide enhanced flexibility while the portions therebetween from which no material has been removed enhance pushability by inhibiting compression of inner tubular member 108. Second portion 128 includes an aperture (e.g., a slit or cut) 132 that extends through the sidewall of inner tubular member 108. Aperture 132 is arranged in the form of an uninterrupted spiral extending along the distal portion of inner tubular member 108. The spiral path from which material has been removed increases the flexibility of inner tubular member 108 along second portion 128. As a result of spiral aperture 132, second portion 128 of inner tubular member 108 has greater flexibility than first portion 126 of inner tubular member 108. The increased flexibility of second portion 128 relative to first portion 126 allows second portion 128 to traverse tortuous regions of body vessels during use. Similarly, the high level of stiffness of first portion 126 relative to second portion 128 enhances the overall pushability of inner tubular member 108.

Apertures 130, 132 can be configured to achieve any of various different desired flexibility characteristics of inner tubular member 108. For example, the pitch of the spiral of apertures 130 and 132 can be decreased to increase the flexibility of first and second portions 126 and 128, respectively. Similarly, the pitch of the spiral of apertures 130 and 132 can be increased to increase the rigidity and pushability of first and second portions 126 and 128, respectively. As another example, the distance between adjacent apertures 130 in the interrupted spiral pattern in first portion 126 can be increased to increase the distal pushability of first portion 126 and can be decreased to increase flexibility of first portion 126. In some embodiments, the pitch of the spiral of aperture(s) 130 and/or 132 decreases in the distal direction, resulting in increased flexibility in the distal direction along aperture(s) 130 and/or 132.

Apertures 130, 132 can be formed in the sidewall of inner tubular member 108 using any of various material removal techniques. For example, a laser can be used to cut apertures 130, 132 into the sidewall of inner tubular member 108. Alternatively or additionally, EDM techniques or mechanical material removal techniques can be used.

Referring again to Figure 2, support member 118 is disposed within inner

lumen 120 of inner tubular member 108 in a region of inner lumen 120 that is adjacent elongate slot and slightly proximal to the location at which a polymeric sleeve 134 exits elongate slot 122. Due to the reduced amount of material in the portion of inner tubular member including elongate slot 122, this portion of inner tubular member 108 tends to be more flexible than the region directly adjacent (e.g., directly proximal or directly distal) to it. In some instances, the portion of inner tubular member 108 that includes elongate slot 122 has a greater flexibility than first and second portions 126 and 128 of inner tubular member 108. The presence of support member 118 in the region of lumen 120 adjacent elongate slot 122 stiffens inner tubular member 108 and inhibits buckling of inner tubular member 108. As will be described in further detail below, when outer tubular assembly 106 is retracted to deploy stent 112, the distal end of support member 118 moves proximally within inner lumen 120 adjacent elongate slot 122, which allows the location at which the guide wire exits elongate slot 122 (i.e., via polymeric sleeve 134) to move proximally during the process.

Support member 118 is a solid member (e.g., a solid wire or a mandrel) that is movable along the longitudinal axis of inner lumen 120. The outer surface of support member 118 contacts the inner surface of inner tubular member 108 in the region of inner tubular member 108 that includes elongate slot 122 and in the region of inner tubular member 108 proximal to elongate slot 122. This contact between support member 118 and inner tubular member 108 provides inner tubular member with radial support, which can inhibit inner tubular member 108 from kinking when compressive forces are applied to it during use. This contact between support member 118 and inner tubular member 108 also prevents distortion or deformation of inner tubular member 108 along elongate slot 122.

An outer diameter of support member 118 and an inner diameter of inner tubular member 108 can be dimensioned to inhibit air from traveling through inner lumen 120 (e.g., to reduce the need to flush the portion of inner tubular member 108 proximal to elongate slot 122). In some embodiments, the clearance between the outer diameter of support member 118 and the inner diameter of inner tubular member 108 is 0.05 millimeters or less. In certain embodiments, the clearance between the outer diameter of support member 118 and the inner diameter of inner tubular member 108 is about 0.025 millimeters to about 0.05 millimeters (e.g., about 0.03 millimeters to about 0.04 millimeters).

Support member 118 can be made of any of various materials. For example,

support member 118 can include one or more metals or alloys, such as stainless steel or Nitinol. In addition or in the alternative, support member 118 can include one or more relatively rigid polymers, such as polyetheretherketone (PEEK) polymers, nylon, polyimides, high durometer polyether block amides (e.g., PEBAX®70D, 5 PEBAX® 72D). In some embodiments, the distal end portion of support member 118 includes one or more relatively rigid materials while the proximal end portion of support member 118 includes more flexible materials.

Referring still to Figure 2, polymeric sleeve 134 extends proximally from distal end 116 of inner tubular member 108 and extends radially through elongate slot 10 122. A proximal end region 138 of sleeve 134 extends into a port 144 formed by outer tubular assembly 106. Sleeve 134 contacts a portion of outer tubular assembly 106 (e.g., in the region of port 144) but is not bonded to outer tubular assembly 106. This arrangement allows outer tubular assembly 106 to be retracted relative to sleeve 134. As will be discussed in further detail below, during use, a guide wire extends 15 through a lumen 136 in sleeve 134. Sleeve 134 helps to direct the guide wire toward port 144 and also helps to prevent metal to metal contact between guide wire 124 and the sidewall of inner lumen 120. Sleeve 134 can also inhibit direct contact between guide wire 124 and support member 118, which can reduce friction between the guide 20 and support member 118. By inhibiting direct contact between guide wire 124 and support member 118, sleeve 134 can also reduce surface changes (e.g., scratches, etc.) to the guide wire. Sleeve 134 can be formed of any of various different polymers, such as polyimides, polytetrafluoroethylene (PTFE), polyethylenes, and nylons. In certain embodiments, the inner surface of sleeve 134 can include a lubricious coating to reduce friction between sleeve 134 and a guide wire that passes therethrough. 25 Examples of lubricious coatings include fluoropolymer (e.g., PTFE) coatings, silicone coatings, ultrahigh molecular weight polyethylene coatings, oil coatings, and coatings formed of blends of two or more of the previously mentioned materials.

Still referring to Figure 2, outer tubular assembly 106 includes a proximal outer sheath 143 secured to the distal end of a tubular rack 218 (shown in Figure 1) 30 and bonded to the proximal end region of a distal outer sheath 142. Proximal outer sheath 143 is arranged over inner tubular member 108. Distal outer sheath 142, which extends distally from proximal outer sheath 143, surrounds stent 112 to retain stent 112 in an unexpanded state when outer tubular assembly 106 is in a fully distal position, as shown in Figure 2. As described in further detail below, distal and

proximal outer sheaths 142, 143 are retractable together in the proximal direction to release stent 112.

A portion of the outer circumference of proximal outer sheath 143 is attached (e.g., thermally bonded, adhesively bonded, etc.) to at least a portion of the inner  
5 circumference of distal outer sheath 142 to form a joint 145. At joint 145, the outer diameter of proximal outer sheath 143 is smaller than the inner diameter of distal outer sheath 142, forming port 144, which accommodates proximal end region 138 of sleeve 134.

Distal and proximal outer sheaths 142, 143 can each be flexible along the  
10 longitudinal axis of catheter assembly 102. For example, distal and proximal outer sheaths 142, 143 can include one or more compliant polymeric materials. Examples of suitable polymeric materials include polyether-block co-polyamide polymers (e.g., PEBAX®), copolyester elastomers (e.g., Arnitel® copolyester elastomers), thermoplastic polyester elastomers (e.g., Hytrel.RTM.), thermoplastic polyurethane  
15 elastomers (e.g., Pellethane™), polyolefins (e.g., Marlex® polyethylene, Marlex® polypropylene), high-density polyethylene (HDPE), low-density polyethylene (LDPE), polyamides (e.g., Vestamid® and combinations of these materials. In certain embodiments, inner tubular member 108 and distal and proximal outer sheaths 142, 143 include one or more silicones. In certain embodiments (e.g., when it is desirable  
20 to reduce force used to retract distal and proximal outer sheaths 142, 143), distal and proximal outer sheaths 142, 143 can be made of a material having a relatively low coefficient of friction (e.g., a fluoropolymer or a silicone). Examples of fluoropolymers include PTFE and FEP. Alternatively or additionally, distal and proximal outer sheaths 142, 143 can be made of a material that includes a lubricious  
25 additive (e.g., a fluoropolymer, a silicone, an ultrahigh molecular weight polyethylene, an oil, or blends thereof). In some embodiments, distal outer sheath 142 can be formed of a different material than proximal outer sheath 143. In such embodiments, for example, distal outer sheath 142 can be formed of a more flexible material than proximal outer sheath 143.

30 Referring again to Fig. 1, outer tubular assembly 106 of catheter assembly 102, further includes tubular rack 218, which is attached to the proximal end of proximal outer sheath 143. Tubular rack 218 includes multiple radially extending teeth 222 that are axially spaced apart along tubular rack 218. A longitudinal slot 224 is formed in the sidewall of tubular rack 218. Slot 224 provides a radial passage from

lumen 110 of outer tubular assembly 106 to an area surrounding tubular rack 218. A pull grip 226 is provided on a proximal end region of tubular rack 218. Pull grip 226 is located proximal to a proximal end 228 of handle assembly 104 and includes radially extending projections that can be grasped by the user.

5           Figure 4 illustrates a section of handle assembly 104 in a partially assembled state with one of the sides of housing 232 removed to show how inner tubular member 108 is secured to housing 232. As shown in Figure 4, inner tubular member 108 is secured to an inner surface of housing 232 by a connector 234 near the proximal end of housing 232. Connector 234 includes a tubular segment 236 through which inner  
10   tubular member 108 partially extends. Inner tubular member 108 is attached (e.g., welded, thermally bonded, adhesively bonded) to the inner surface of tubular segment 236. A rib portion 238 extends radially outwardly from tubular segment 236 and is attached (e.g., welded, thermally bonded, adhesively bonded, insert molded) to the inner surface of the side wall of housing 232 of handle assembly 104. As a result,  
15   connector 234 and inner tubular member 108 are axially fixed relative to housing 232.

          Figure 5 illustrates a side view of handle assembly 104 in an operable configuration with the near side of its housing 232 (i.e., the side of housing 232 to which connector 234 is secured, as shown in Figure 4) removed to expose certain interior components of handle assembly 104. As shown in Figure 5, a rotatable knob  
20   240 is rotatably mounted to housing 232. Rotatable knob 240 includes a pin 242 that extends laterally from a side surface of rotatable knob 240 and can be disposed within a cylindrical recess defined by the side wall housing 232. Rotatable knob 240 also includes a gear 244 that laterally extends from the side surface of rotatable knob 240. Gear 244 includes multiple circumferentially spaced teeth 246 that extend radially  
25   from a peripheral surface of gear 244. A top wall 248 of housing 232 includes an aperture 250 through which an upper portion of rotatable knob 240 protrudes to allow rotatable knob 240 to be rotated by the thumb of a user.

          Referring to Figures 4 and 5, support member 118 extends through inner tubular member 108 and beyond connector 234 in the proximal direction. Support  
30   member 118 is axially movable relative to housing 232, while inner tubular member 108 is axially fixed relative to housing 232. Thus, in use, support member 118 is retractable relative to inner tubular member 108. Support member 118 is attached (e.g., welded, thermally bonded, adhesively bonded, etc.) to a portion of tubular rack 218 proximal to connector 234. As a result, support member 118 is retracted when

tubular rack 218 is retracted. In certain embodiments, the outer surface of support member 118 is attached to the inner surface of tubular rack 218 proximal to connector 234. A proximal end region of support member 118 can alternatively or additionally be attached to pull grip 226.

5 Referring still to Figures 4 and 5, in the operable configuration, inner tubular member 108, support member 118, and tubular rack 218 of catheter assembly 102 extend within a cavity formed by housing 232 of handle assembly 104. Teeth 222 of tubular rack 218 mate with teeth 246 of gear 244. Thus, tubular rack 218, as well as support member 118 which is fixed to tubular rack 218, can be axially displaced by  
10 rotating rotatable knob 240. Tubular rack 218 extends entirely through handle assembly 104 such that, in an initial configuration, a proximal region of tubular rack 218 extends proximal to a proximal end 228 of handle assembly 104 and a distal region of tubular rack 218 extends distal to distal end 252 of handle assembly 104. Housing 232 of handle assembly 104 includes proximal and distal openings 254, 256  
15 that provide sufficient clearance for tubular rack 218, support member 118, and proximal outer sheath 143 to pass through the openings and thus move axially through housing 232 without substantial interference.

Figure 6 illustrates a cross-sectional view of handle assembly 104 in a fully assembled configuration (i.e., with the near side of housing 232 in place). As shown  
20 in Figure 6, rib portion 238 of connector 234 extends radially through slot 224 of tubular rack 218. Slot 224 is configured (e.g., sized and shaped) so that tubular rack 218 can be retracted relative to connector 234 while rib portion 238 extends through slot 224.

Referring to Figures 5 and 6, slot 224 extends from the proximal end of  
25 tubular rack 218 to a location proximal to the distal end of tubular rack 218. As a result, tubular rack 218 can be proximally retracted until rib portion 238 of connector 234 abuts the distal end of slot 224. Due to the arrangement of slot 224, when outer tubular assembly 106 and support member 118 are fully retracted, the distal end of tubular rack 218 is located proximal to proximal end 228 of handle assembly 104 and  
30 portions of proximal outer sheath 143 and support member 118 are retracted into housing 232 of handle assembly 104.

Distal and proximal outer sheaths 142, 143 and support member 118 can be simultaneously retracted using either rotatable knob 240 or pull grip 226. To retract distal and proximal outer sheaths 142, 143 and support member 118 using rotatable

knob 240, the user rotates rotatable knob 240 in a clockwise direction (in the view illustrated in Figure 5). The rotation of gear 244 causes teeth 246 of gear 244 to engage teeth 222 of tubular rack 218, and thereby proximally displace tubular rack 218. Because tubular rack 218 is secured to proximal outer sheath 143 and support member 118, the proximal displacement of tubular rack 218 results in retraction of distal and proximal outer sheaths 142, 143 and support member 118 at the same rate. To retract distal and proximal outer sheaths 142, 143 and support member 118 using pull grip 226, the user grasps pull grip 226 and pulls pull grip 226 in the proximal direction.

Figures 7A-7D illustrate a method of using system 100 to implant stent 112 within a blood vessel 158 of a patient. Referring to Figure 7A, guide wire 124 is first inserted into blood vessel 158, and catheter assembly 102 is passed over guide wire 124 toward a treatment site. To pass catheter assembly 102 over guide wire 124, the proximal end of guide wire 124 is first inserted into lumen 136 of polymeric sleeve 134 via distal openings in polymeric sleeve 134 and inner tubular member 108. Catheter assembly 102 is then backloaded onto guide wire 124 by passing the distal end portion of inner tubular member 108 over the proximal end portion of guide wire 124. As inner tubular member 108 is further passed over guide wire 124 in the distal direction, guide wire 124 passes through sleeve 134, exits elongate slot 122, and exits catheter assembly 102 via port 144. Guide wire 124 exits elongate slot 122 with sleeve 134 disposed between guide wire 124 and the sidewall of inner tubular member 108 that defines elongate slot 122. Sleeve 134 provides a path for guide wire 124 to follow through catheter assembly 102. Sleeve 134 inhibits metal-to-metal contact between guide wire 124 and the sidewall of inner tubular member 108. Proximal to port 144, guide wire 124 extends along the exterior surface of catheter assembly 102. A distal portion of catheter assembly 102 is navigated through blood vessel 158 and toward an occluded region 162 of blood vessel 158 by passing catheter assembly 102 over guide wire 124.

The distal portion of catheter assembly 102 is navigated through blood vessel 158 until the stent-carrying portion of catheter assembly 102 is positioned within occluded region 162 of blood vessel 158, as shown in Figure 7B. Fluoroscopy or any of various other imaging techniques can be used to help the user position the stent-carrying portion of catheter assembly 102 within occluded region 162.

Referring to Figure 7C, after positioning the stent-carrying portion of catheter

assembly 102 within occluded region 162, tubular rack 218, support member 118, and distal and proximal outer sheaths 142, 143 are retracted an initial distance relative to inner tubular member 108 by rotating rotatable knob 240 in a clockwise direction (in the view illustrated in Figure 7C). This initial retraction of distal outer sheath 142  
5 allows a distal portion of stent 112 to self-expand within occluded region 162 and contact a wall of body vessel 158. Retraction of tubular rack 218 moves distal and proximal outer sheaths 142, 143 proximally relative to inner tubular member 108 and guide wire 124. In addition, because support member 118 is fixed to tubular rack 218, support member 118 also moves proximally within lumen 120 of inner tubular  
10 member 108. As support member 118 retracts, the point of contact between sleeve 134 and the distal end of support member 118 moves proximally, allowing sleeve 134 to change orientation such that an increased portion of sleeve 134 extends into inner lumen 120. The portion of guide wire 124 disposed within sleeve 134 changes profile along with sleeve 134, while guide wire 124 remains substantially fixed in the  
15 longitudinal direction. For example, sleeve 134 and a portion of guide wire 124 disposed therein can initially form substantially "s" shaped profiles and, as support member 118 retracts, the inflection points of the "s" shaped profiles move proximally. As the inflection points of sleeve 134 and guide wire 134 move proximally, sleeve 134 and guide wire 124 remain substantially, longitudinally fixed relative to inner tubular  
20 member 108.

This proximal movement of support member 118 inhibits sleeve 134 and/or guide wire 124 from becoming pinched between distal outer sheath 142 and the distal end of support member 118. This arrangement helps to ensure that distal outer sheath 142 can be retracted a sufficient distance to fully deploy stent 112. In addition, as  
25 discussed above, sleeve 134 inhibits contact between guide wire 124 and inner tubular member 108 as guide wire 124 changes profile (e.g., as described above) along elongate slot 122.

Referring to Figure 7D, the user subsequently pulls proximally on pull grip 226 until the stent is fully deployed. For example, the user can pull proximally on  
30 pull grip 226 until the distal end of slot 224 abuts rib portion 238 of connector 234, preventing further retraction of tubular rack 218, support member 118, and distal and proximal outer sheaths 142, 143. In this fully retracted position, the entire length of tubular rack 218 is proximal to distal end 252 of handle assembly, and proximal portion of proximal outer sheath 143 resides within the cavity formed by housing 232



of handle assembly 104. Pull grip 226 generally permits the user to retract tubular rack 218, support member 118, and distal and proximal outer sheaths 142, 143 more rapidly than rotatable knob. In addition, pull grip 226 permits the user to retract distal and proximal outer sheaths 142, 143 even when the portion of tubular rack 218 that includes teeth 222 thereon has been retracted proximally beyond rotatable knob 240, rendering rotatable knob 240 incapable of retracting distal and proximal outer sheaths 142, 143 and support member 118 when rotated. As distal outer sheath 142 is retracted past the proximal end of stent 112, the full length of stent 112 is allowed to self-expand to a larger diameter and contact the blood vessel wall.

After deploying stent 112, system 100 and guide wire 124 are withdrawn from blood vessel 158, leaving stent 112 in blood vessel 158.

Due to the rapid exchange configuration of system 100, system 100 can be quickly exchanged with another system (e.g., a system of a different size or a different type of system) during use. To exchange systems, the user pulls handle assembly 104 proximally to move catheter assembly 102 proximally over guide wire 124. At the same time, the user holds the proximal end portion of guide wire 124 outside of the patient's body to help ensure that guide wire 124 remains in a substantially axially fixed position within the blood vessel. The user continues to retract catheter assembly 102 until the proximal end of guide wire 124 has passed distally beyond the distal end of catheter assembly 102 (e.g., distally beyond the distal end of sleeve 134 and the tip of catheter assembly 102). At this point, the user can backload a new system over guide wire 124 and navigate the new system to a desired region of treatment within the blood vessel.

While certain embodiments have been described, other embodiments are possible.

As an example, while inner tubular member 108 has been described as being formed of stainless steel, it can be formed of any of various materials that allow it to be deflected and articulated, e.g., to traverse a tortuous body vessel. For example, as an alternative to or in addition to stainless steel, inner tubular member 108 can be formed of one or more other metals and/or alloys, such as Nitinol. Alternatively or additionally, inner tubular member 108 can include one or more polymeric materials, such as polyetheretherketone (PEEK) polymers, nylon, polyimides, and high durometer polyether block amides (e.g., PEBAX® 70D, PEBAX® 72D).

As another example, while system 100 has been described as including sleeve

134 disposed within a distal portion of lumen 120 of inner tubular member 108, certain embodiments include no such sleeve.

In some embodiments, the distal end of the support member is shaped to direct a guide wire toward port 144 of outer tubular assembly 106. For example, as shown  
5 in Figure 8, the distal end of a support member 418 forms a ramped portion 419. In operation, the distal end portion of inner tubular member 408 is backloaded over the proximal end of guide wire 124. The catheter assembly is moved distally relative to guide wire 124 such that the proximal end of guide wire 124 moves within an inner  
10 lumen 420 of an inner tubular member 408, toward ramped portion 419 of support member 418. As the catheter assembly continues to move distally relative to guide wire 124, ramped portion 419 of support member 418 directs the proximal end of guide wire 124 out of inner lumen 420 through an elongate slot 422 formed in the side wall of inner tubular member 408. As the catheter assembly moves still further in the distal direction relative to guide wire 124, the proximal end of guide wire 124 exits the  
15 catheter assembly via port 144.

Still referring to Figure 8, support member 418 includes a radial projection 460 configured to be received in a channel 462 formed in the side wall of inner tubular member 408. Radial projection 460 and channel 462 cooperate to limit rotation of support member 418 relative to inner tubular member 408. This arrangement helps to  
20 ensure proper orientation of support member 418 to allow guide wire 124 to be directed toward port 144. Moreover, this arrangement helps to ensure that this proper orientation of support member 418 is maintained while support member 418 is being retracted relative to inner tubular member 408.

As another example, while projection 460 in the system described above  
25 extends radially from the support member 418 and channel 462 is formed in the side wall of inner tubular member 408, other arrangements are possible. For example, in certain embodiments, the locations of the projection and channel are reversed such that the projection extends from the inner tubular member and the channel is formed in the support member.

30 As still another example, while the support members and inner lumens of the above-described systems have circular cross-sectional areas, in some embodiments, at least a portion of the support member includes a non-circular cross-section and at least a portion of a lumen of the inner tubular member has a non-circular cross-section. For example, as shown in Figure 9, a support member 518 and an inner lumen

520 of an inner tubular member 508 each have a rectangular (e.g., square) cross-section such that support member 518 is inhibited from rotating relative to inner tubular member 508. As an alternative to or in addition to rectangular cross-sections, any of various other cross-sections that can inhibit rotation of the support member  
5 relative to the inner tubular member can be used.

As another example, other embodiments for inhibiting rotation of the support member relative to the inner tubular member are possible. For example, the inner tubular member can include a lip extending into the inner lumen. The lip can be arranged to engage a ramped portion of the support member to inhibit further distal  
10 motion of the support member. The lip can be further arranged to limit rotational movement of the support member when the ramped portion of the support member is substantially engaged with the lip of the inner tubular member.

As yet another example, while the embodiments described above are configured to inhibit rotation of the support member relative to the inner tubular  
15 member, in certain embodiments, the support member is allowed to freely rotate relative to the inner tubular member.

As another example, while the inner tubular members of the systems above have been described as including an elongate slot defined by the sidewall of the inner tubular member, other types of openings can be formed in the side wall of the inner  
20 tubular member to allow a guide wire to pass therethrough. For example, the sidewall of the inner tubular member can include a circular aperture, an elliptical aperture, etc.

As still another example, while the inner tubular members of the systems above have been described without a polymer coating, the inner member can include a polymer coating (e.g., to prevent sharp edges from apertures 130, 132 from causing  
25 damage to catheter assembly 102). For example, the inner tubular member can include a polymer coating over its entire length. As another example, the inner tubular member can include a polymer coating over a portion of the inner tubular member (e.g., in the region of apertures 130, 132). The polymer coating can include high durometer polyether block amides (e.g., PEBAX® 70D, PEBAX®72D), heat  
30 shrunk polyethylene terephthalate (PET), nylon, polyimides, a polytetra-fluoroethylene (PTFE) sleeve, etc.

As another example, while first and second pattern of apertures 130, 132 in inner tubular member 108 have been described as including an interrupted spiral pattern and an uninterrupted spiral pattern, respectively, other arrangements can be

used. For example, first and second apertures 130, 132 can each include an interrupted spiral pattern or can each include an interrupted spiral pattern. As another example, one or both of first and second apertures 130, 132 can include a combination of an interrupted and uninterrupted spiral pattern. As a further example, first and second apertures 130, 132 can include vertical slots extending substantially perpendicular to the longitudinal axis of inner tubular member 108. The vertical slots defining apertures 130 along first portion 126 of inner tubular member 108 can be substantially spaced apart to allow first portion 126 to allow some flexibility while enhancing overall pushability of the inner tubular member 108. The vertical slots defining apertures 132 along second portion 128 of inner tubular member 108 can be spaced close together (e.g., a minimum distance required to maintain structural strength of inner tubular member 108 along second portion 128) to allow second portion 128 to traverse tortuous regions of body vessels during use.

As still another example, in certain embodiments, distal outer sheath 142 includes a multi-layer construction to facilitate containing stent 112 in a compressed state prior to deployment. In certain embodiments, for example, distal outer sheath 142 includes an inner layer formed of PTFE, a middle layer formed of a stainless steel mesh, and an outer layer formed of nylon 12 and/or polyether block amide (e.g., PEBA). Any of various techniques can be used to attach tubular rack to outer sheath. For example, tubular rack and outer sheath can be adhesively bonded, thermally bonded, welded, etc.

As yet another example, while outer tubular assembly 106 has been described as including distal and proximal outer sheaths 142, 143, other embodiments are possible. For example, referring to Figure 10, the outer tubular assembly can include a single, continuous outer sheath 300. A port 344 extends through the sidewall of continuous outer sheath 300, near distal end 316, to allow a guide wire to extend through the continuous outer sheath. Port 344 can extend at an acute angle (e.g., a 45 degree angle) relative to the longitudinal axis of outer sheath 300 to reduce stress imparted on a guide wire by continuous outer sheath 300 as the guide wire exits port 344 and extends substantially parallel to the longitudinal axis of the outer sheath 300. Such an angled arrangement can, for example, reduce friction between the guide wire and outer sheath 300 as outer sheath 300 is retracted relative to the guide wire. Additionally or alternatively, the port extending through the side wall of outer sheath 300 can extend at any of various other angles. In some embodiments, for example, the

port extends substantially perpendicular to the longitudinal axis of outer sheath 300.

As still another example, while support member has been described as a solid wire or mandrel, other configurations can be used. For example, as shown in Figure 11, a support member 618 includes a support portion 620 attached to a pull wire 622. This and other similar embodiments reduce the amount of material required to form the support member and help to localize added rigidity to the region of the inner tubular member in which the support portion is located. During use, support portion 620 can be positioned adjacent an elongate slot in an inner tubular member to prevent kinking, prolapsing, or otherwise deforming along the elongate slot of the inner tubular member. Pull wire 622 can be used to move support portion 620 in the distal direction as the stent is deployed. For example, pull wire 622 can be attached to a tubular rack in a manner similar to that in which support member 118 is attached to tubular rack 218.

As another example, while stent delivery system 100 has been described as including a support member, the stent delivery system 100 can be configured without a support member. In some embodiments, the portion of the inner tubular member proximal to the aperture is solid.

As a further example, while the stent deployment methods described above include retracting tubular rack 218, support member 118, and distal and proximal outer sheaths 142, 143 by rotating rotatable knob 240 and then pulling proximally on pull grip 226, other techniques can be used. In certain embodiments, for example, tubular rack 218, support member 118, and distal and proximal outer sheaths 142, 143 are retracted by pulling proximally on pull grip 226 only. Alternatively, tubular rack 218, support member 118, and distal and proximal outer sheaths 142, 143 can be retracted by rotating rotatable knob 240 only. In certain embodiments, tubular rack 218, support member 118, and distal and proximal outer sheaths 142, 143 are retracted for an initial distance by pulling proximally on pull grip 226 and then retracted the remaining distance by rotating rotatable knob 240.

As an additional example, while the systems above have been described as being used to deliver and deploy self-expanding stents, in certain embodiments, the system can be used to deliver and deploy other types of implantable medical endoprostheses, such as stent-grafts, and filters (e.g., arterial and venous filters).

As another example, while the systems above have been described as being used in various different types of blood vessels, the systems can alternatively or

additionally be used in any of various other types of body vessels.

Other embodiments are in the claims.

**WHAT IS CLAIMED IS:**

1. A system, comprising:  
an outer tubular member defining a lumen;  
an inner tubular member extending within the lumen of the outer tubular member, the inner tubular member having a sidewall defining an aperture configured to allow a guide wire to pass therethrough, the inner and outer tubular members being configured so that an implantable medical endoprosthesis can be disposed between the inner and outer tubular members;  
a support member disposed in a lumen of the inner tubular member, the support member being configured such that at least a portion of the support member can be disposed adjacent the aperture, the support member and the outer tubular member being configured to retract relative to the inner tubular member.
2. The system of claim 1, wherein the aperture is a longitudinally extending elongate slot.
3. The system of claim 2, wherein the elongate slot has a length greater than or equal to a length of an implantable medical endoprosthesis disposed between the outer tubular member and the inner tubular member.
4. The system of any of claims 1-3, wherein the inner tubular member is of unitary construction.
5. The system of any of claims 1-4, wherein the inner tubular member is formed of one or more metals.
6. The system of any of claims 1-5, wherein a portion of the sidewall of the inner tubular member proximal to the aperture defines a plurality of cuts.
7. The system of claim 6, wherein the cuts are in the form of an interrupted spiral.
8. The system of any of claims 1-7, wherein a portion of the sidewall of the inner tubular member distal to the aperture defines at least one cut.

9. The system of claim 8, wherein the at least one cut is in the form of a continuous spiral.
10. The system of any of claims 1-9, wherein the support member is longitudinally fixed relative to the outer tubular member.
11. The system of claim 10, wherein a distal end portion of the support member is longitudinally fixed relative to the outer tubular member at a location adjacent an opening in a sidewall of the outer tubular member.
12. The system of any of claims 1-11, wherein a distal end portion of the support member is shaped to direct a guide wire into the aperture when the guide wire is passed through the lumen of the inner tubular member in a proximal direction.
13. The system of any of claims 1-12, wherein the support member is substantially rotationally fixed relative to the inner tubular member.
14. The system of claim 13, wherein at least a portion of the support member has a non-circular cross-section and at least a portion of the lumen of the inner tubular member has a non-circular cross-section.
15. The system of claim 13, wherein the support member comprises a radial projection configured to be received in a longitudinal channel defined by the inner tubular member.
16. The system of any of claims 1-15, further comprising a sleeve extending within a distal portion of the inner tubular member and being configured to allow a guide wire to be passed through the sleeve.
17. The system of claim 16, wherein the sleeve comprises a polymer.
18. The system of claim 16, wherein the sleeve is arranged to direct a guide wire into the aperture when the guide wire is passed through the sleeve in a proximal direction.



19. The system of claim 18, wherein the sleeve comprises a proximal portion that extends into the aperture.
20. The system of any of claims 1-19, further comprising an implantable medical endoprosthesis disposed between the outer tubular member and the inner tubular member.
21. The system of claim 20, wherein the implantable medical endoprosthesis is a self-expanding implantable medical endoprosthesis.
22. A system, comprising:
  - an inner tubular member having a sidewall defining an elongate slot, the inner tubular member being formed of one or more metals;
  - an outer tubular member at least partially surrounding the inner tubular member, the outer tubular member having a sidewall at least partially defining an opening arranged such that a guide wire can be passed through the elongate slot of the inner tubular member and the opening of the outer tubular member, the inner tubular member and the outer tubular member being arranged such that an implantable medical endoprosthesis can be disposed between the inner tubular member and the outer tubular member.
23. The system of claim 22, wherein the elongate slot extends longitudinally along the inner tubular member.
24. The system of claim 23, wherein the elongate slot has a length greater than or equal to a length of an implantable medical endoprosthesis disposed between the outer tubular member and the inner tubular member distal to the elongate slot.
25. The system of any of claims 22-24, wherein the inner tubular member is of unitary construction.
26. The system of any of claims 22-25, wherein a portion of the sidewall of the inner tubular member proximal to the elongate slot defines a plurality of cuts.

27. The system of claim 26, wherein the cuts are in the form of an interrupted spiral.
28. The system of any of claims 22-27, wherein a portion of the sidewall of the inner tubular member distal to the elongate slot defines at least one cut.
29. The system of claim 28, wherein the at least one cut is in the form of a continuous spiral.
30. The system of any of claims 22-29, further comprising a support member disposed in a lumen of the inner tubular member, the support member being configured such that at least a portion of the support member can be disposed adjacent the aperture, and the support member being arranged to retract relative to the inner tubular member.
31. The system of claim 30, wherein a distal end portion of the support member is configured to direct a guide wire toward the aperture when the guide wire is passed through a lumen of the inner tubular member in a proximal direction.
32. The system of claim 30, wherein the support member is longitudinally fixed relative to the outer tubular member.
33. The system of claim 32, wherein a distal end portion of the support member is longitudinally fixed relative to the outer tubular member at a location adjacent the opening in the sidewall of the outer tubular member.
34. The system of any of claims 22-33, further comprising a sleeve extending within a distal portion of the inner tubular member and being configured to allow a guide wire to be passed through the sleeve.
35. The system of claim 34, wherein the sleeve is arranged to direct a guide wire into the aperture when the guide wire is passed through the sleeve in a proximal direction.

36. The system of any of claims 22-35, further comprising an implantable medical endoprosthesis disposed between the inner tubular member and the outer tubular member.

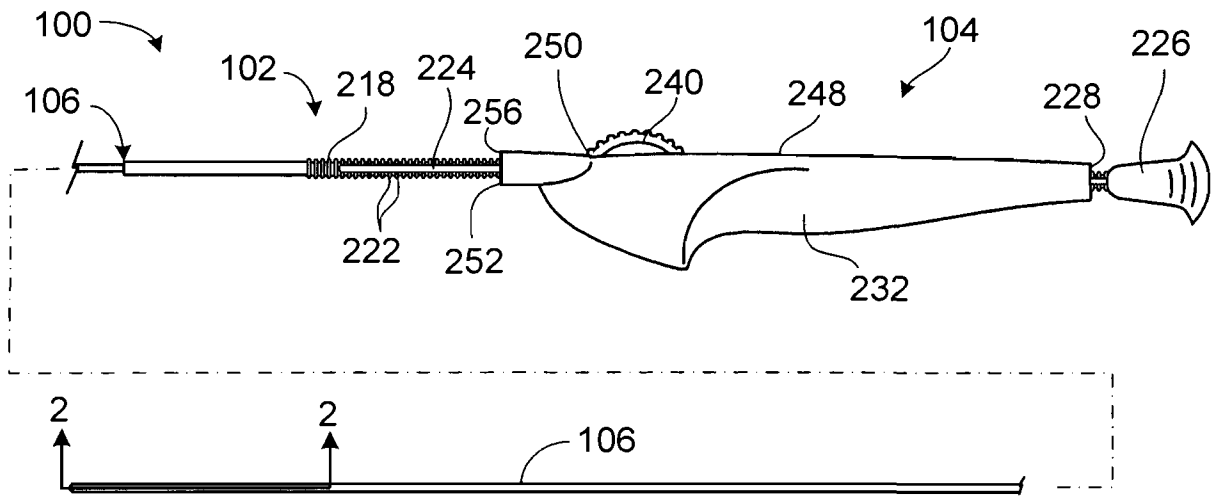

FIG. 1

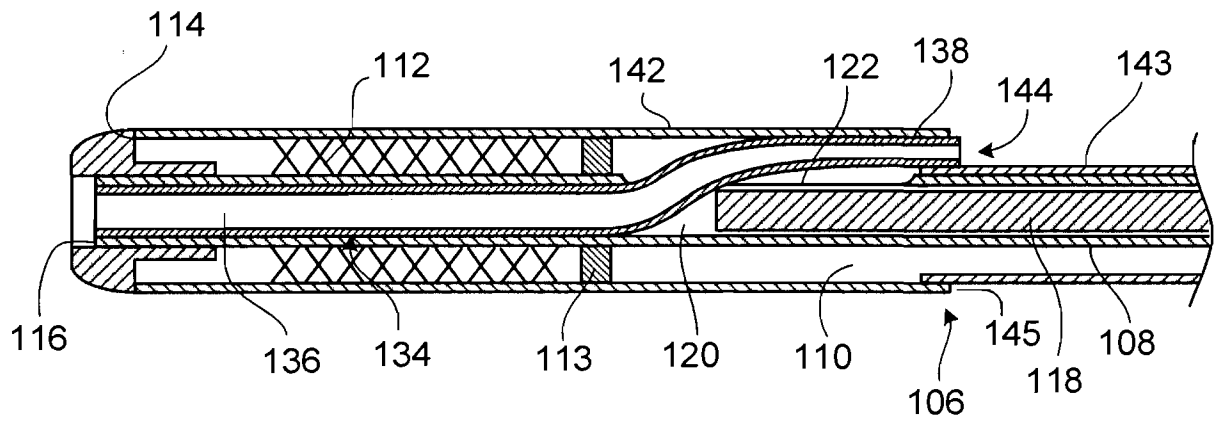
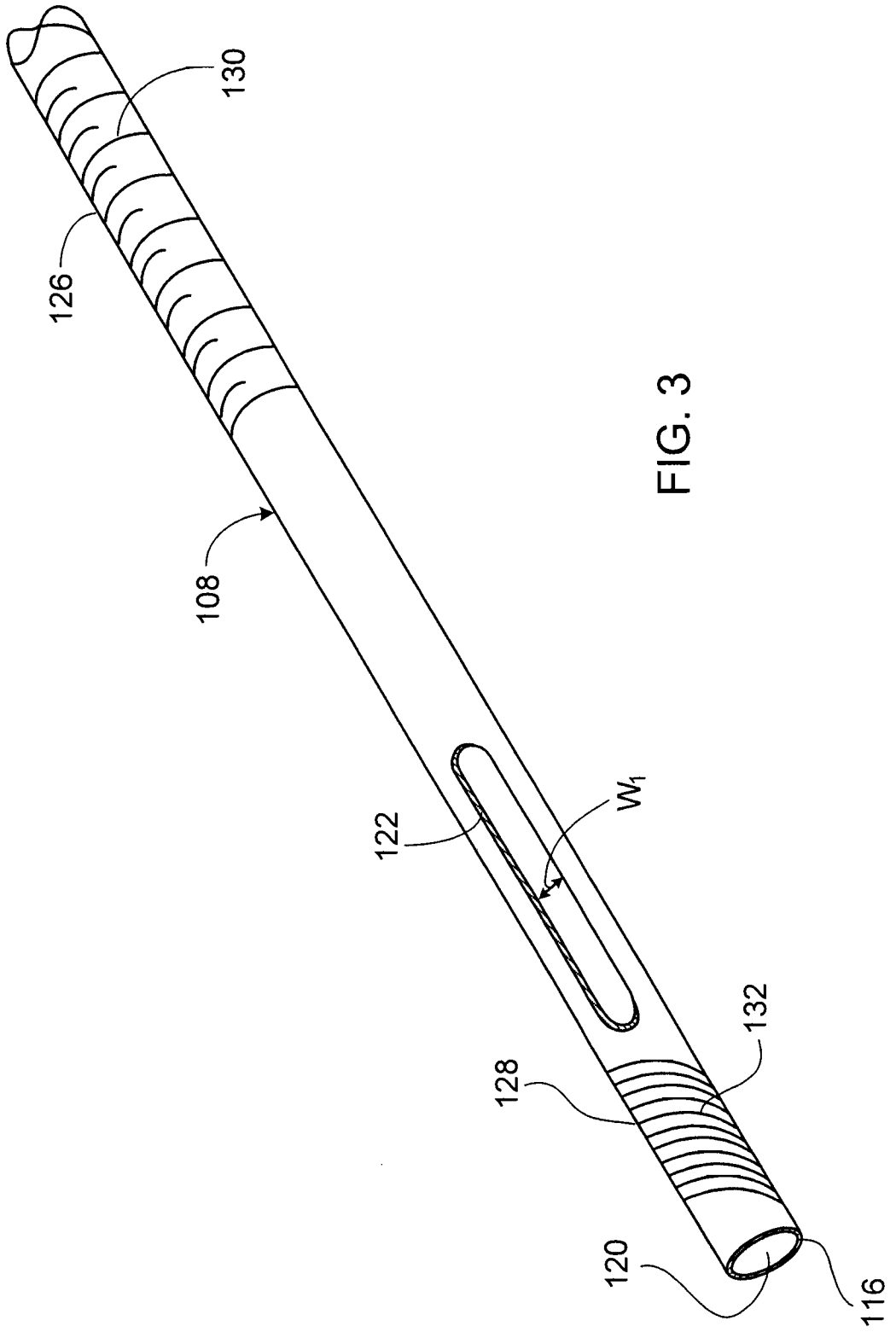

FIG. 2



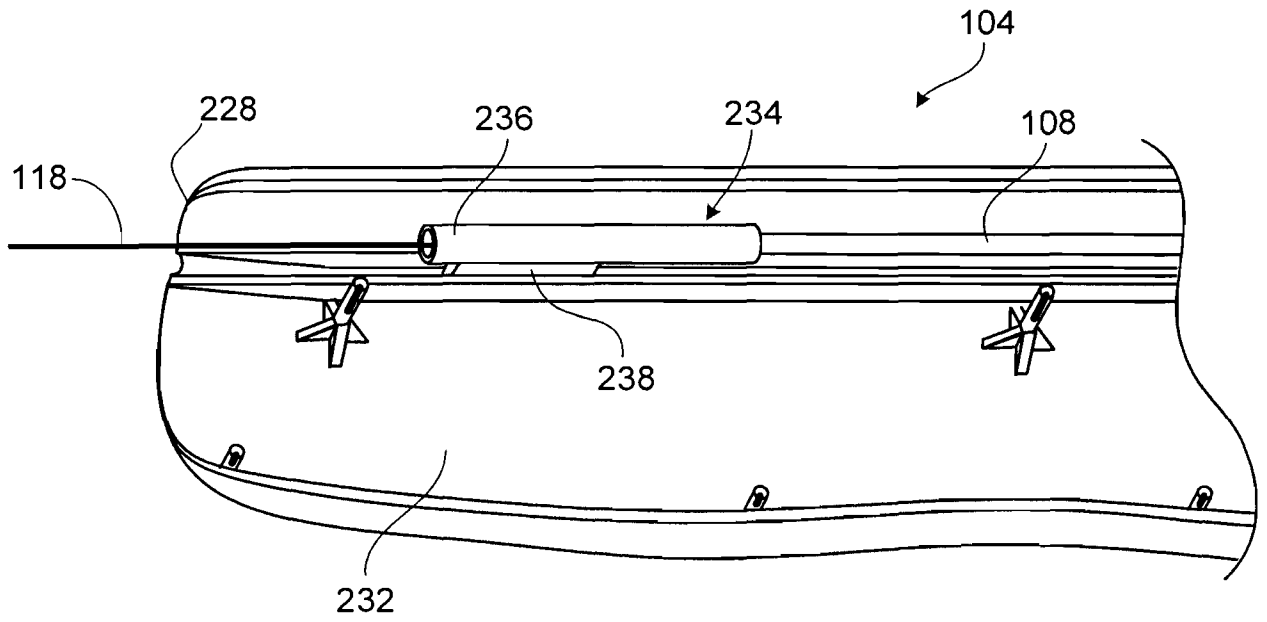

FIG. 4



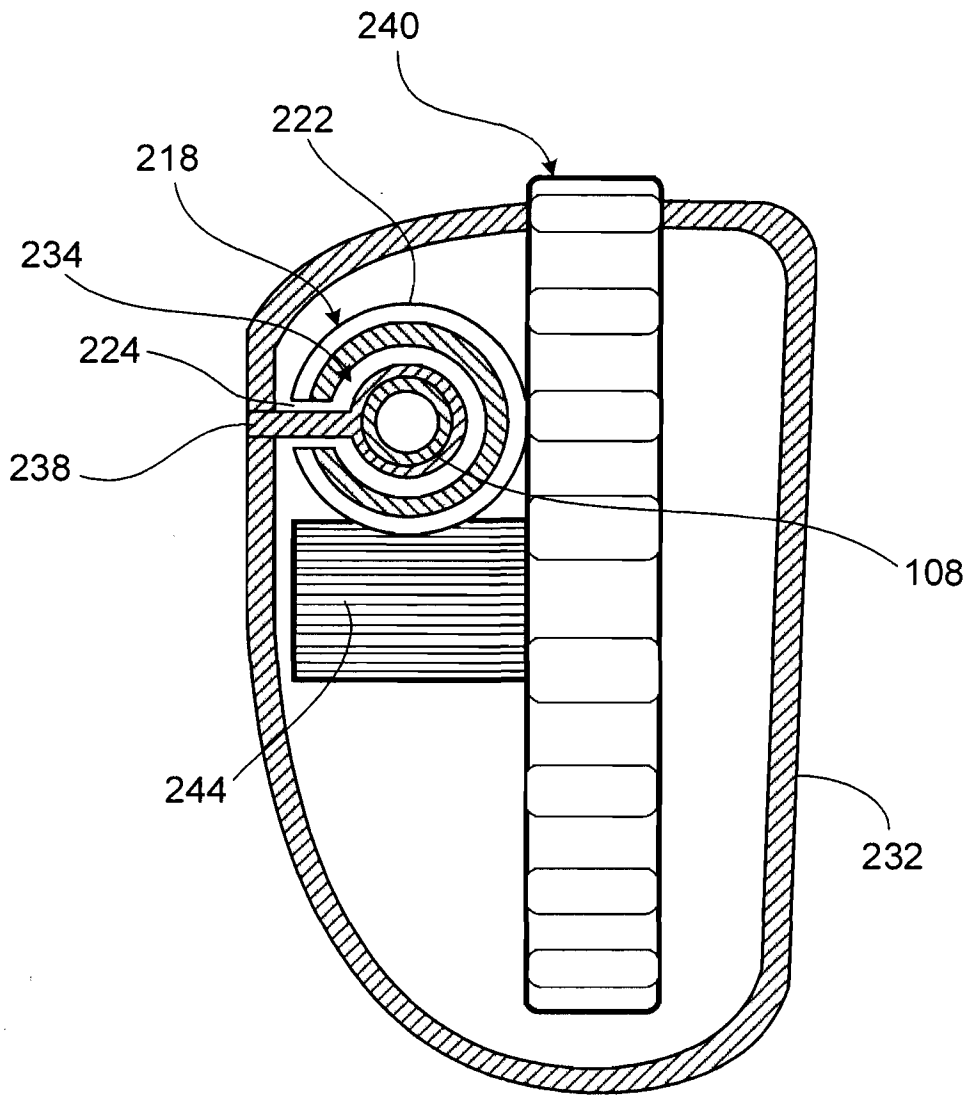

FIG. 6





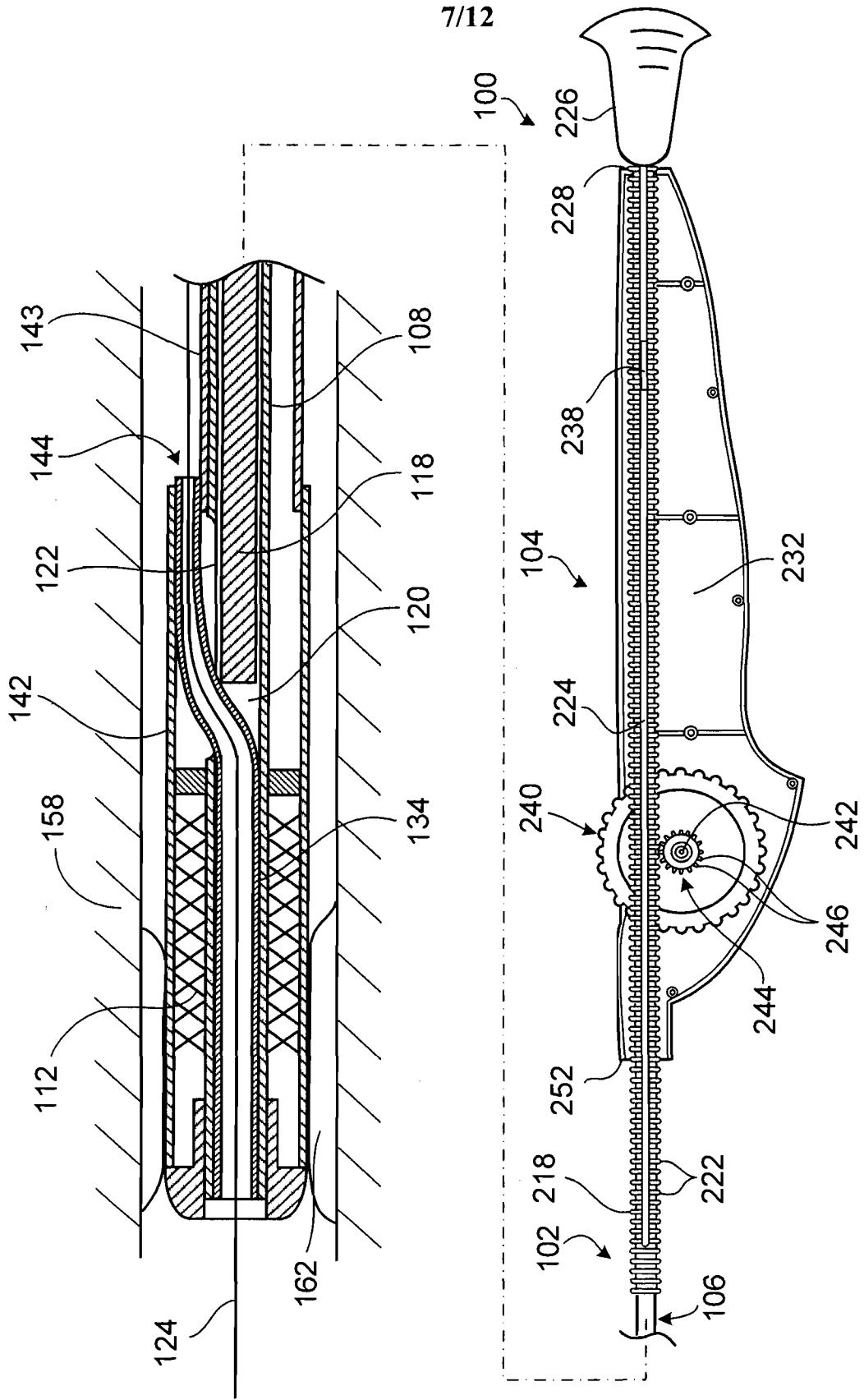

FIG. 7B

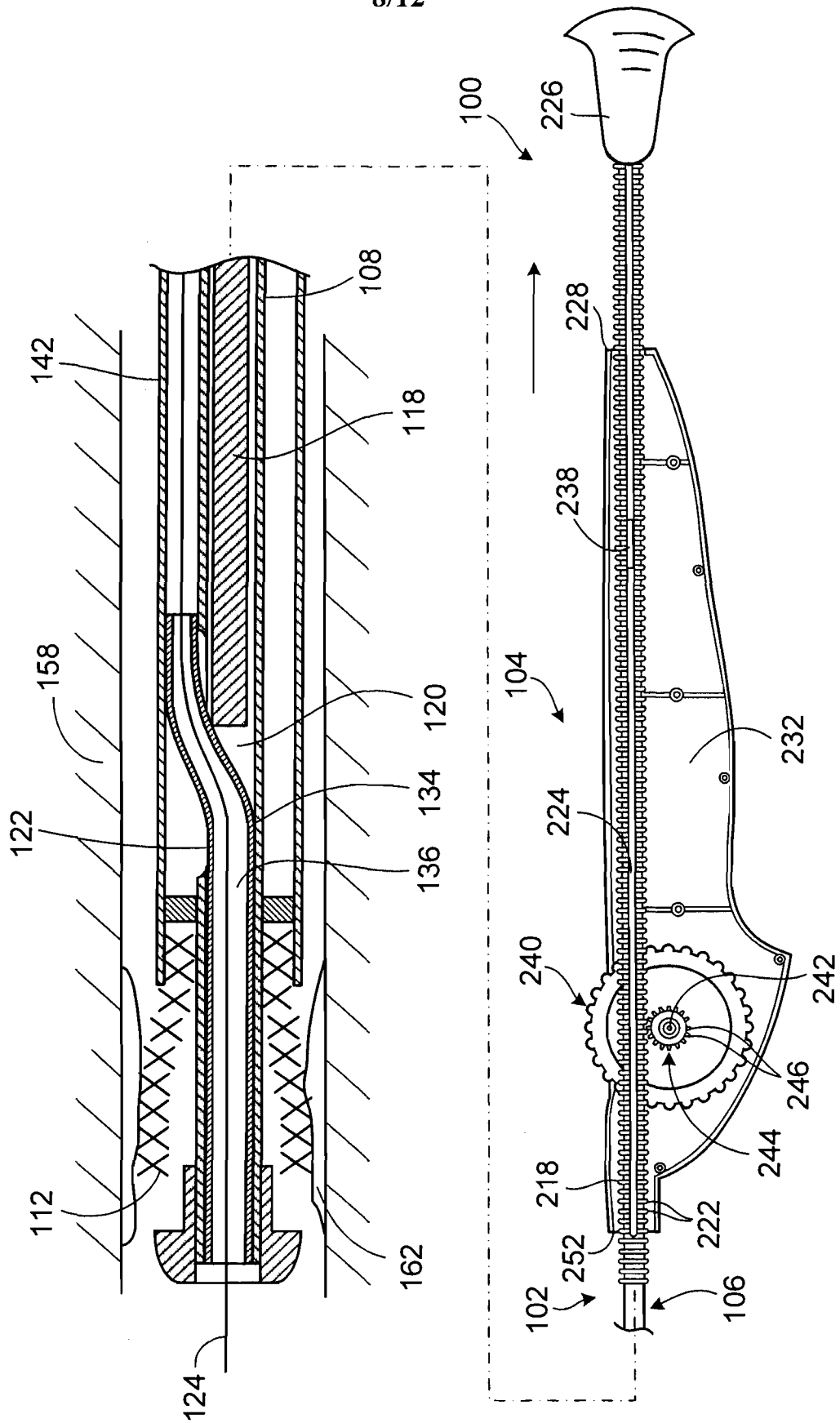

FIG. 7C



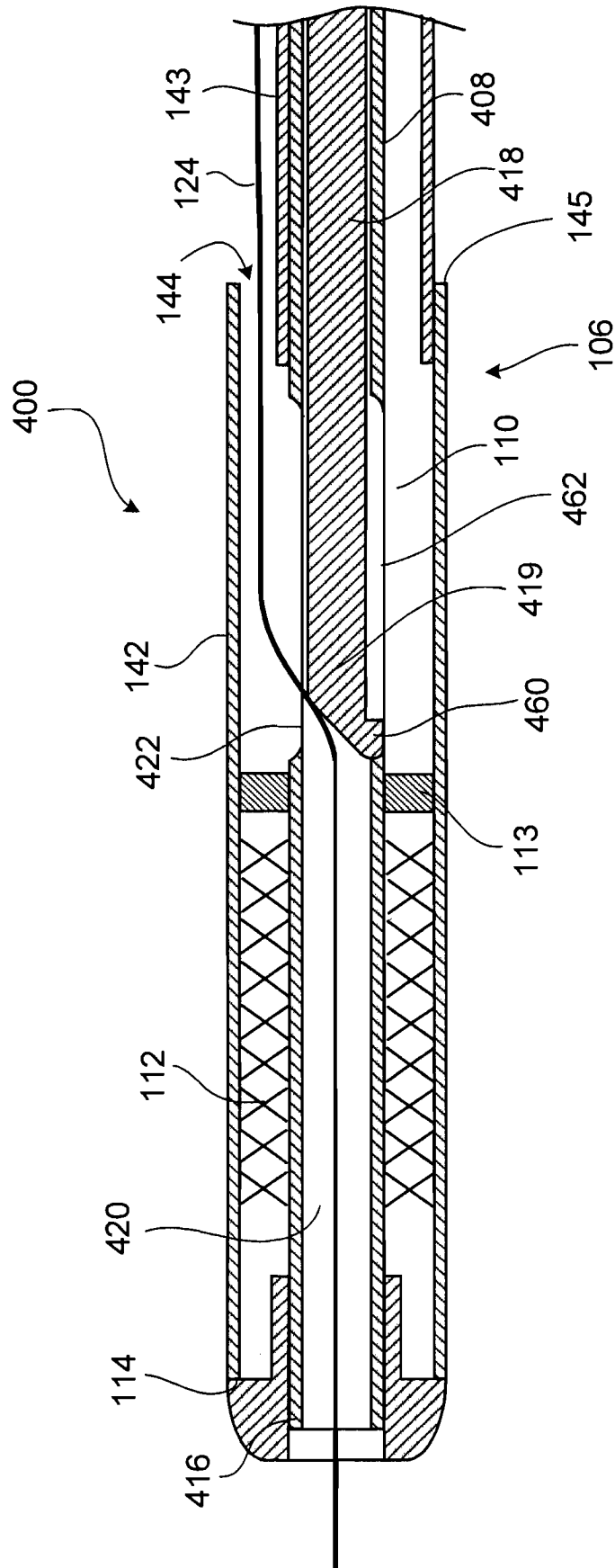

FIG. 8

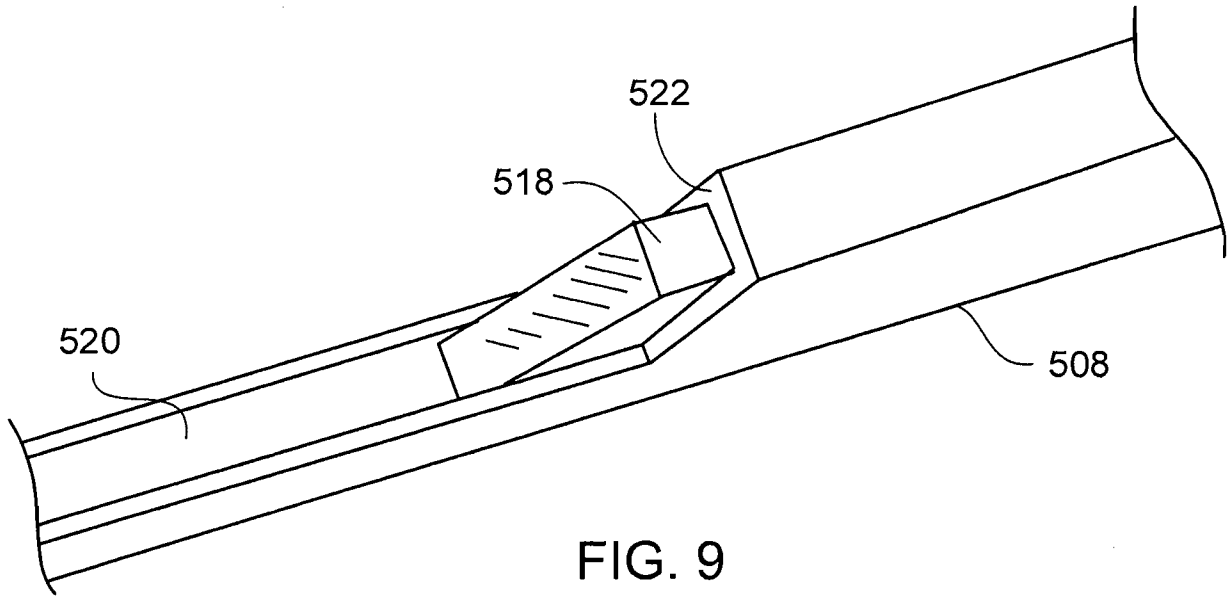

FIG. 9

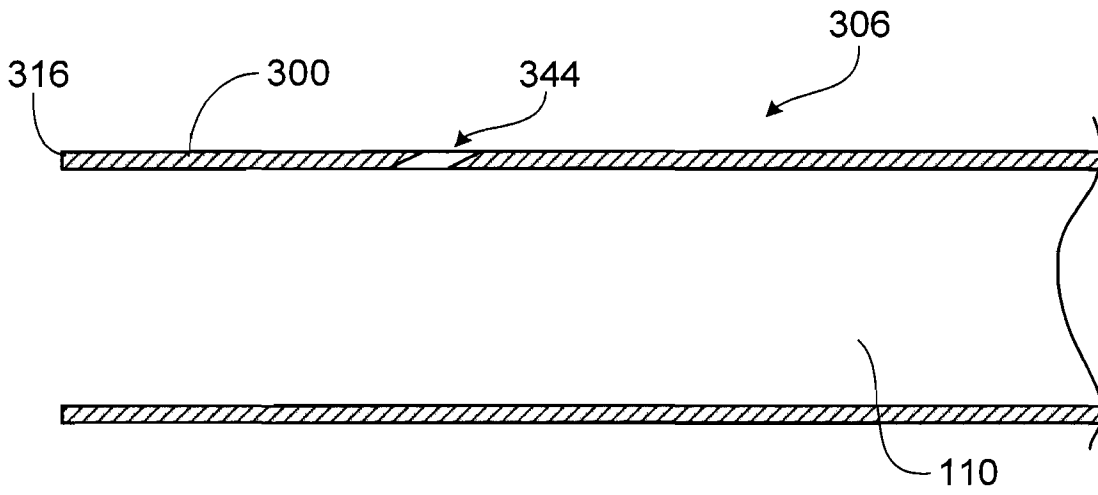

FIG. 10

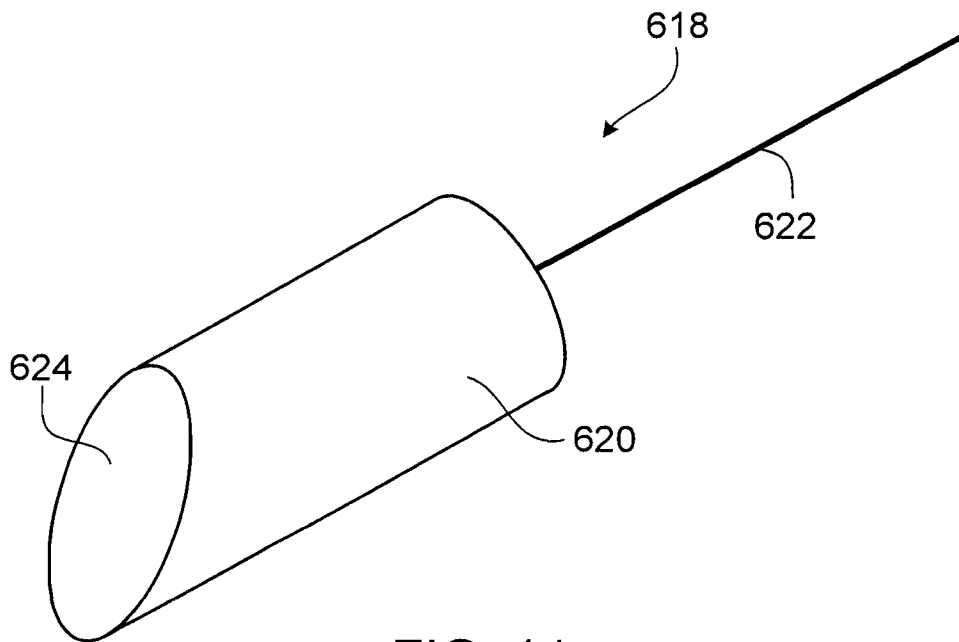

FIG. 11

## INTERNATIONAL SEARCH REPORT

International application No

PCT/US2009/032738

## A. CLASSIFICATION OF SUBJECT MATTER

INV. A61F2/84

According to International Patent Classification (IPC) or to both national classification and IPC

## B. FIELDS SEARCHED

Minimum documentation searched (classification system followed by classification symbols)

A61F A61M

Documentation searched other than minimum documentation to the extent that such documents are included in the fields searched

Electronic data base consulted during the international search (name of data base and, where practical, search terms used)

EPO-Internal

## C. DOCUMENTS CONSIDERED TO BE RELEVANT

Category*	Citation of document, with indication, where appropriate, of the relevant passages	Relevant to claim No.
X	US 2003/093106 A1 (BRADY EAMON [IE] ET AL) 15 May 2003 (2003-05-15) paragraph [0126] - paragraph [0254]	1-36
X	US 2006/282147 A1 (ANDREAS BERNARD [US]) 14 December 2006 (2006-12-14) figures 2a,2b paragraph [0072] paragraph [0078] - paragraph [0084]	1-3
P,X	WO 2008/039846 A (BOSTON SCIENT SCIMED INC [US]; EIDENSCHINK TRACEE E J [US]; HEIDNER MA) 3 April 2008 (2008-04-03) page 4, line 5 - page 21, line 2	22-36
A	WO 2007/110224 A (ANGIOMED AG [DE]; DORN JUERGEN [DE]) 4 October 2007 (2007-10-04) page 9, line 5 - page 15, line 5	1-36
	-/--	

 Further documents are listed in the continuation of Box C. See patent family annex.

\* Special categories of cited documents :

- \*A\* document defining the general state of the art which is not considered to be of particular relevance
- \*E\* earlier document but published on or after the international filing date
- \*L\* document which may throw doubts on priority claim(s) or which is cited to establish the publication date of another citation or other special reason (as specified)
- \*O\* document referring to an oral disclosure, use, exhibition or other means
- \*P\* document published prior to the international filing date but later than the priority date claimed

\*T\* later document published after the international filing date or priority date and not in conflict with the application but cited to understand the principle or theory underlying the invention

\*X\* document of particular relevance; the claimed invention cannot be considered novel or cannot be considered to involve an inventive step when the document is taken alone

\*Y\* document of particular relevance; the claimed invention cannot be considered to involve an inventive step when the document is combined with one or more other such documents, such combination being obvious to a person skilled in the art.

\*Z\* document member of the same patent family

Date of the actual completion of the international search

11 March 2009

Date of mailing of the international search report

26/03/2009

Name and mailing address of the ISA/

European Patent Office, P.B. 5818 Patentlaan 2  
 NL - 2280 HV Rijswijk  
 Tel. (+31-70) 340-2040,  
 Fax: (+31-70) 340-3016

Authorized officer

Mary, Céline



## INTERNATIONAL SEARCH REPORT

International application No  
PCT/US2009/032738

C(Continuation). DOCUMENTS CONSIDERED TO BE RELEVANT

Category*	Citation of document, with indication, where appropriate, of the relevant passages	Relevant to claim No.
A	US 2003/109886 A1 (KEEGAN MARTIN [IE] ET AL) 12 June 2003 (2003-06-12) figures 2e,3b-3j,5 paragraph [0117] - paragraph [0190] -----	1-21

# INTERNATIONAL SEARCH REPORT

Information on patent family members

International application No PCT/US2009/032738
---

Patent document cited in search report	A1	Publication date	Patent family member(s)	Publication date
US 2003093106	A1	15-05-2003	NONE	
US 2006282147	A1	14-12-2006	AU 2006309285 A1 CA 2610950 A1 EP 1887978 A2 JP 2008545505 T US 2006282148 A1 US 2006282149 A1 US 2007027521 A1 US 2008071345 A1 WO 2007053187 A2	10-05-2007 10-05-2007 20-02-2008 18-12-2008 14-12-2006 14-12-2006 01-02-2007 20-03-2008 10-05-2007
WO 2008039846	A	03-04-2008	US 2008077085 A1	27-03-2008
WO 2007110224	A	04-10-2007	NONE	
US 2003109886	A1	12-06-2003	US 2008039863 A1	14-02-2008