

[72] Inventor **Wilfried Herbst**
Essen, Germany
 [21] Appl. No. **810,204**
 [22] Filed **March 25, 1969**
 [45] Patented **Nov. 24, 1970**
 [73] Assignee **Heinrich Koppers Gesellschaft mit**
beschränkter
Haftung, Essen, Germany
 [32] Priority **March 26, 1968**
 [33] **Germany**
 [31] **12,921, 32.3**

Primary Examiner—Robert G. Sheridan
 Attorney—Stanley J. Price, Jr.

[54] **APPARATUS FOR CLOSING THE COAL HOPPER**
OUTLET ON A LARRY CAR
5 Claims, 5 Drawing Figs.

[52] U.S. Cl. **214/18,**
202/263
 [51] Int. Cl. **C10b 31/04**
 [50] Field of Search **214/18,**
18PH, 35, 35A; 202/262, 263

[56] **References Cited**
UNITED STATES PATENTS
 3,070,516 12/1962 Wethly **214/18X**
FOREIGN PATENTS
 971,533 9/1964 Great Britain **214/18**

ABSTRACT: This disclosure relates to apparatus for preventing the flow of coke oven gas from a coke oven into a larry car coal hopper. The larry car has a plurality of coal hoppers that carry the coal from the storage bins to the coke ovens. The coal is discharged from the hopper through a discharge chute into a charging hole in the roof of the coke oven. A turntable serves as the bottom wall of the hopper and upon rotation discharges a controlled amount of coal through a tapered chute that extends from an outlet opening in the hopper side wall. The tapered chute has a depending telescopic sleeve that is positioned in the charging hole of a coke oven. A normally closed check valve is positioned in the discharge chute and closes and seals the outlet opening in the hopper sidewall. The check valve includes a pair of partially overlapped plates pivotally secured adjacent their upper edges to the chute sidewalls. The plates are pivoted upwardly by the stream of coal being discharged through the opening in the hopper side wall and pivot downwardly by gravity to close the opening when the hopper is empty and thus prevent the flow of gas from the coking chamber into the coal hopper. A lever on the check valve actuates a switch to provide a signal that the hopper is empty and may also deenergize the drive for rotating the turntable.

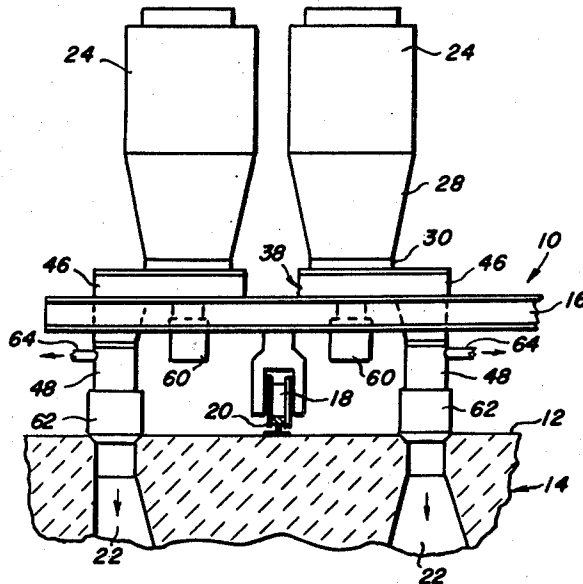

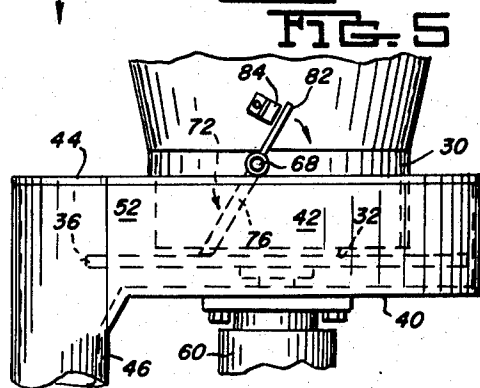
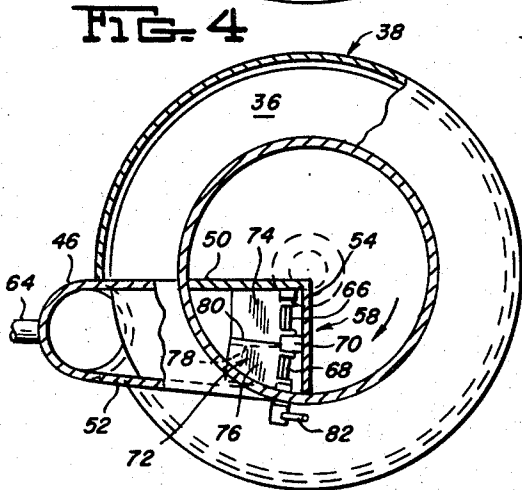
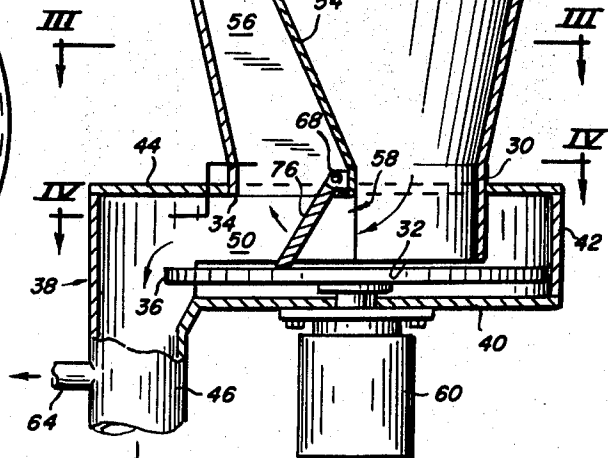
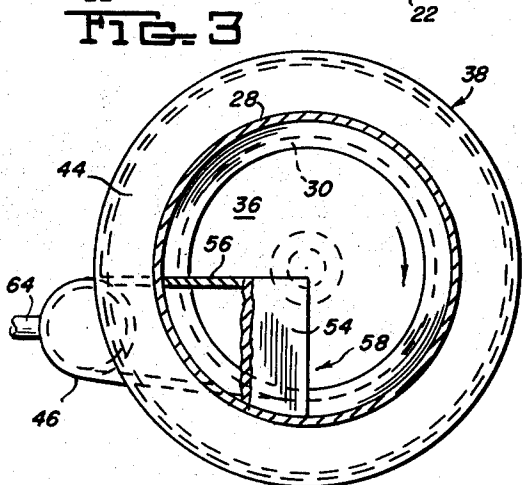
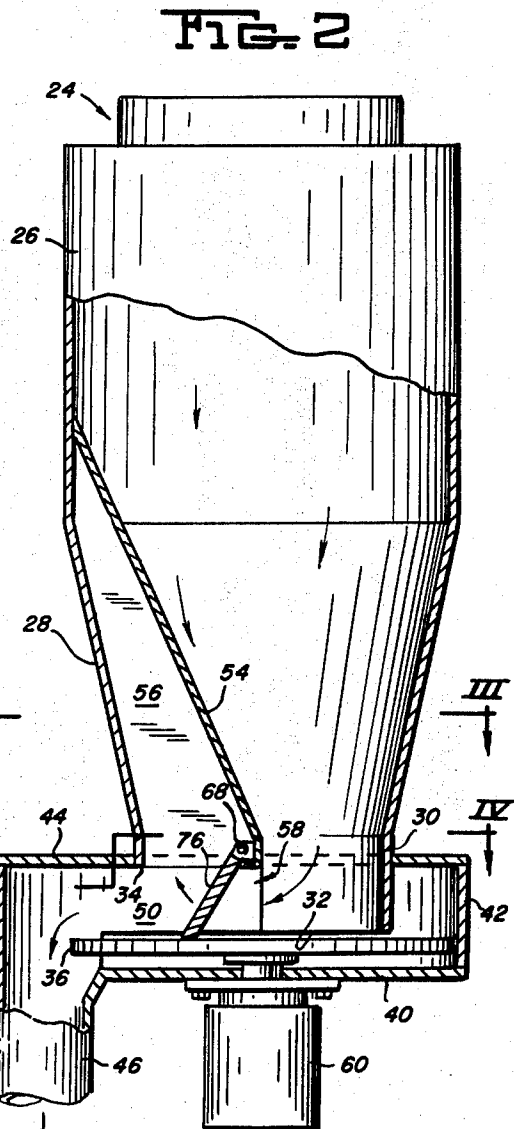
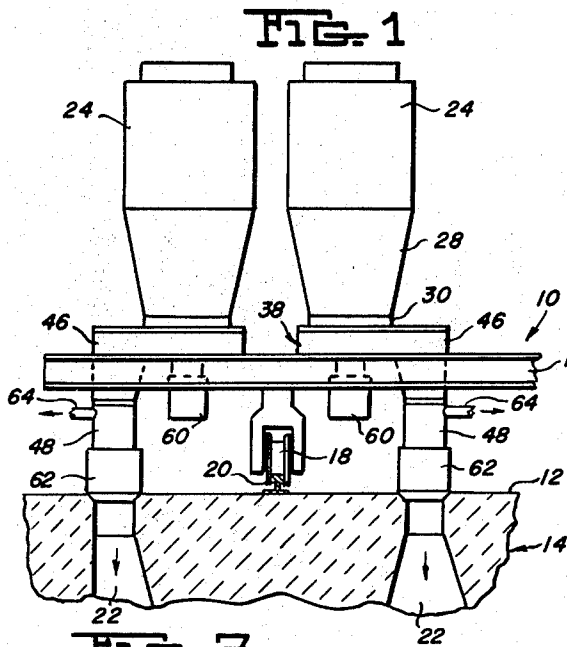

APPARATUS FOR CLOSING THE COAL HOPPER OUTLET ON A LARRY CAR

BACKGROUND OF THE INVENTION

1. Field of the Invention

The invention relates to apparatus for preventing the flow of gases from the coke oven into the larry car coal hoppers and more particularly to a valve that automatically closes the outlet opening in a larry car coal hopper sidewall when the hopper is empty and thereby prevents the flow of coke oven gas into the coal hopper.

2. Description of the Prior Art

Horizontal byproduct coke ovens are charged with coal by conveying the coal from storage bins to the coke ovens in the coal hoppers on the larry car. The larry car is mounted on rails on the top of the coke oven battery and moves longitudinally along the battery from the storage bins to the coke oven to be charged. The coke oven batteries have a plurality of charging holes in the top of the battery for each of the transverse coke ovens and the same number of coal hoppers are provided on the larry car. The larry car is positioned with the coal hoppers in overlying relation with the charging holes and the coal is discharged from the hoppers by means of a turntable. Rotation of the turntable discharges the coal through a chute connected to an opening in the sidewall of the hopper. The chute has a depending telescopic sleeve positioned in the charging hole of the coke oven battery. As the coal fills the coking chamber through the charging holes, the gases within the coke oven and the coal dust have a tendency to flow upwardly from the coke oven chamber through the charging holes and through the depending telescopic sleeve into the coal hopper. There is an inherent danger that the gas from the coke oven entering the hopper will mix with the oxygen of the air present in the hopper and either ignite or explode. Even though the gas does not ignite or explode, it is discharged into the atmosphere from the top of the hopper and is a source of air pollution. There is a need, therefore, for apparatus to prevent the coke oven gases and coal dust from entering the coal hopper of a larry car.

SUMMARY OF THE INVENTION

The hereinafter described invention is directed to apparatus for sealing the coal hopper outlet on a larry car and includes a check valve positioned in the tapered chute connected to the outlet opening in the sidewall of the coal hopper. The normally closed check valve pivots upwardly to open the outlet by the stream of coal discharged through the outlet opening upon rotation of the turntable. When the coal hopper is empty the check valve pivots downwardly by gravity into abutting relation with the turntable and seals the outlet opening in the coal hopper to thereby prevent the flow of gas into the coal hopper.

Accordingly, the principal object of this invention is to provide an automatic sealing means for the outlet opening of a coal hopper after the coal has been discharged therefrom.

Another object of this invention is to provide a means to prevent the gases from a coke oven from flowing into the coal hopper after the coal has been discharged therefrom.

These and other objects and advantages of this invention will be more completely disclosed and described in the following specification, the accompanying drawings and the appended claims.

BRIEF DESCRIPTION OF THE DRAWINGS

FIG. 1 is a fragmentary view in elevation of a portion of a larry car with a pair of coal hoppers positioned for charging a coke oven chamber through adjacent charging holes in the roof of the oven.

FIG. 2 is a view in elevation and partially in section of a coal hopper with a check valve closing the outlet in the hopper sidewall.

FIG. 3 is a view in section taken along the line III-III of FIG. 2 illustrating the portion of the chute extending into the coal hopper and serving as a scraper to direct the coal from the turntable into the depending sleeve portion of the chute.

FIG. 4 is a view in section taken along the lines IV-IV of FIG. 2 illustrating in detail the tapered sidewalls of the chute and the partially overlapped plates of the valve positioned in the tapered chute.

FIG. 5 is a fragmentary view in elevation illustrating the actuator portion of the valve that actuates a signal device when the hopper is empty.

DESCRIPTION OF THE PREFERRED EMBODIMENT

Referring to the drawings there is illustrated a portion of a larry car generally designated by the numeral 10 positioned on the top 12 of a coke oven battery generally designated by the numeral 14. The larry car 10 has a frame member 16 with depending trolley wheels 18 mounted thereon. The trolley wheels 18 are positioned on longitudinal rails 20 on the coke oven battery roof 12 to permit longitudinal movement of the larry car 10 from the coal storage bins to the coking chambers of the coke oven battery. Each coking chamber has a plurality of charging holes 22 through which the coal is introduced into the coking chambers.

A plurality of coal hoppers 24 are mounted on the frame 16 of the larry car 10 and are filled with a preselected volume of coal at the storage bin. The larry car 10 is moved into charging position to discharge the coal from the hoppers 24 into the respective charging holes 22 of the particular oven being charged.

FIGS. 2-5 illustrate the coal hopper 24 in greater detail. The coal hopper 24 has a cylindrical upper portion 26 and an inverted conical intermediate portion 28 that terminates in a lower cylindrical end portion 30. The lower cylindrical portion 30 has a lower circular opening 32 and a discharge opening 34 in the sidewall. A turntable 36 abuts the bottom edge of the circular hopper lower portion 30 and closes the opening 32. A housing 38 has a base portion 40 with upstanding circular sidewall 42 and a top portion 44. A chute generally designated by the numeral 46 (FIGS. 3 and 4) extends tangentially from the hopper lower portion 30 and has a depending telescopic sleeve 48. The chute 46 has a sidewall 50 that extends into the hopper 24 to a location adjacent the axial center of the turntable 36 and a tangential other sidewall 52 that extends from the hopper wall 30. Positioned within the hopper 24 are a pair of inclined plates 54 and 56 which are in overlying relation with the portion of the chute extending into the hopper 24 to enclose that portion of the chute and form a horizontal opening 58 within the hopper 24 that is aligned with the opening 34 in the hopper sidewall. The lower edge of plate 56 is secured to the upper edge of plate 50 of the tapered chute 46.

The turntable 36 is rotated by a motor 60 positioned therebeneath and suitably secured to the base portion 40 of housing 38. The sidewall 50 of chute 46 serves as a scraper within the hopper 24 to direct the coal on the turntable 36 outwardly into the depending sleeve 48 of chute 46 into the charging hole 22.

To discharge the coal from the hopper 24 into the charging hole 22, the motor 60 is energized to rotate the turntable 36. Upon rotation, the coal on the turntable 36 is directed against the scraper sidewall 50 of chute 46 to flow downwardly through the sleeve member 48 into the charging hole 22. The depending sleeve 48 has a telescopic portion 62 (FIG. 1) that connects the depending sleeve 48 to the charging hole 22 and seals the opening therebetween. There is an opening in the sidewall of the depending sleeve 48 to which conduit 64 is connected. The conduit 64 is arranged to convey the gases from the coke oven chamber that flow upwardly through the charging hole 22 to a washer or the like before they are discharged to the atmosphere.

A pair of shafts 66 and 68 are rotatably secured to the chute sidewalls 50 and 52 in suitable bearings adjacent the opening 58. The shafts are suitably supported within the chute 48 by a support means 70 nonrotatably secured to a depending portion of the plate 54. A check valve generally designated by the numeral 72 includes a pair of plate members 74 and 76 that

have their upper portions nonrotatably secured to the respective shafts 66 and 68. The plates 74 and 76 are preferably fabricated from a gas impermeable material that is relatively flexible and relatively noncombustible. The plates 74 and 76 may be fabricated from metal, rubber, plastic or the like. The plates 74 and 76 have their side edge portions 78 and 80 in overlapped relation to conform to the taper between the chute sidewalls 50 and 52. The plates 74 and 76 have their lower edge portions in abutting relation with the upper surface of turntable 36 so that when the hopper 24 is empty the plates 74 and 76 seal or close the outlet opening 58 to prevent the flow of gas through the chute 56 into the hopper 24. The shaft 68 has a portion extending outwardly beyond the chute sidewall 52 and has an upstanding arm portion 82 connected thereto. The arm portion is rotatable with the shaft 68 and is arranged when the check valve 72 is in the normally closed position as illustrated in FIG. 5 to close switch 84 and provide a signal that the hopper 24 is empty. The switch 84 may also be arranged to deenergize the turntable motor 60.

The above described check valve 72 operates in the following manner. When the turntable 36 is rotating to discharge the coal from the hopper 24, the coal entering the chute 46 pivots the plates 74 and 76 of the check valve 72 upwardly so that the check valve 72 is open and does not interfere with the discharge of the coal from hopper 24 by means of turntable 36. When all of the coal has been discharged from the hopper 24 the plates 74 and 76 of check valve 72 move by their own weight into the position illustrated in FIG. 2 with the lower edge portions of the plates 74 and 76 in abutting relation with the upper surface of turntable 36 to close the opening 58 to prevent the flow of gas into the hopper 24. As the plates 74 and 76 move by gravity into the position illustrated in FIGS. 2 and 5, the arm 82 actuates the switch 84 to provide a signal that the hopper 24 is empty and deenergize the turntable motor 60. The gases flowing upwardly through the charging holes 22 into the sleeve member 48 are conveyed through conduit 64 to a suitable washer before they are discharged into the atmosphere.

With the above described invention there is now provided an automatic valve device 72 within the discharge chute 46 that is automatically opened when the coal is being discharged from the hopper 24 and substantially fills the opening 58. The valve 72 automatically closes by gravity when all of the coal has been discharged from the hopper 24 to seal or close the openings 58 to prevent the flow of gas into the hopper 24.

According to the provisions of the patent statutes, the principle, preferred construction and mode of operation of this invention have been explained and what is considered to represent its best embodiment has been illustrated and described.

I claim:

1. Apparatus for closing the coal hopper outlet opening on a larry car to prevent the flow of gas from a coke oven chamber into the coal hopper comprising:

- a larry car mounted on rails and operable to move longitudinally on the roof of a coke oven battery above the coking chambers;
- a coal hopper positioned on said larry car and having a bottom opening and a side opening adjacent said bottom opening;
- a rotatable turntable positioned in abutting relation with the bottom of said hopper and closing said hopper bottom opening, said turntable operable upon rotation relative to

said hopper to discharge coal from said hopper through said side opening;

a discharge chute extending from said side opening and having a depending telescopic sleeve member operable to be positioned in a charging hole of a coke oven chamber; and

a normally closed valve member positioned in said discharge chute, said valve member being operable to close said hopper side opening and arranged to be opened by the coal being discharged into the chute by the turntable, said valve member operable to close when the hopper is empty to thereby seal the hopper side opening and prevent gas from the coke oven chamber from flowing upwardly into said coal hopper.

2. Apparatus for closing the coal hopper outlet opening on a larry car as set forth in claim 1 in which:

said valve member includes plate means supported adjacent said plate means upper edge portion on a shaft means within said discharge chute;

said plate means operable to pivot upwardly about the axis of said shaft means to an open position by the coal being discharged from said hopper into said chute by said turntable; and

said plate means operable to pivot downwardly by gravity into a closed position with said plate means lower edge portion in abutting relation with the upper surface of said turntable when said hopper is empty.

3. Apparatus for closing the coal hopper outlet opening on a larry car as set forth in claim 1 in which:

said discharge chute including a pair of tapered sidewalls;

said valve member includes a pair of plates positioned in side by side relation with the adjacent edges of said plates in overlapped relations, said plate members supported adjacent their upper edges on a shaft means within said discharge chute, said plate members operable to pivot upwardly about the axis of said shaft means to an open position by the coal being discharged from said hopper into said chute by said turntable; and

said plate members operable to pivot downwardly by gravity into a closed position with the plate members lower edge portions in abutting relation with the upper surface of said turntable when said hopper is empty, said plate members having their adjacent edge portions in overlapped relation to close the coal hopper outlet opening between said tapered sidewalls.

4. Apparatus for closing the coal hopper outlet on a larry car as set forth in claim 1 which includes:

actuator means connected to said valve member; and

signal means, said actuator means operable to actuate said signal means when said valve member is in a closed position and provide a signal that said coal hopper is empty.

5. Apparatus for closing the coal hopper outlet opening on a larry car as set forth in claim 2 in which:

said shaft means extends through a sidewall of said discharge chute;

an arm member secured adjacent one end to said shaft means externally of said discharge chute; and

a switch member mounted on said hopper external wall adjacent said shaft means, said arm member operable to pivot with said plate means and actuate said switch means when said plate means is in a closed position to thereby provide a signal that said hopper is empty.

65

70

75