



US00D755549S

(12) **United States Design Patent**
Akkad

(10) **Patent No.:** **US D755,549 S**

(45) **Date of Patent:** **** May 10, 2016**

(54) **CHECKERED SAUCER CHAIR**
(71) Applicant: **Idea Nuova, Inc.**, New York, NY (US)
(72) Inventor: **Benjamin S. Akkad**, New York, NY (US)

2,473,090 A 6/1949 Becker
2,587,543 A 2/1952 Smith
2,590,049 A 3/1952 Sidlinger
D168,212 S 11/1952 Cicchelli
D168,843 S 2/1953 Johnson

(Continued)

(73) Assignee: **Idea Nuova, Inc.**, New York, NY (US)

FOREIGN PATENT DOCUMENTS

(**) Term: **14 Years**

CN 87201431 U 2/1988
CN 2103938 U 5/1992

(Continued)

(21) Appl. No.: **29/499,507**

OTHER PUBLICATIONS

(22) Filed: **Aug. 15, 2014**

(51) **LOC (10) Cl.** **06-01**

U.S. Appl. No. 29/510,669 by Akkad, filed Dec. 2, 2014.

(52) **U.S. Cl.**
USPC **D6/716; D6/368**

(Continued)

(58) **Field of Classification Search**
USPC D6/334-336, 368, 369, 371-373, 375,
D6/376, 379, 716, 716.1, 716.3, 716.4
CPC A47C 4/00; A47C 4/02; A47C 4/03;
A47C 4/24; A47C 4/28; A47C 4/48; A47C
5/02; A47C 7/282; A47C 7/285; A47C 5/04;
A63B 69/00

Primary Examiner — Mimosa De
(74) *Attorney, Agent, or Firm* — Panitch Schwarze Belisario
& Nadel LLP

(57) **CLAIM**
The ornamental design for a checkered saucer chair, as shown
and described.

See application file for complete search history.

(56) **References Cited**

DESCRIPTION

U.S. PATENT DOCUMENTS

244,216 A 7/1881 Fenby
398,943 A 3/1889 Crandall
615,476 A 12/1898 Chapman
1,027,692 A 5/1912 Cole
1,185,568 A 5/1916 Zeunert
1,263,717 A 4/1918 Stone
1,443,734 A 1/1923 Clyde
D80,605 S 3/1930 Chapman
D90,572 S 8/1933 Brown
1,939,743 A 12/1933 Warner
1,942,112 A 1/1934 McQuilkin
D121,141 S 6/1940 Larsen
2,381,574 A 8/1945 Clarin
D151,967 S * 12/1948 Cunningham D6/369

FIG. 1 is a front perspective view of a checkered saucer chair in accordance with a preferred embodiment of my new design;
FIG. 2 is a front elevation view thereof;
FIG. 3 is a left side elevation view thereof, a right side elevation view thereof being a mirror image;
FIG. 4 is a rear elevation view thereof;
FIG. 5 is a top plan view thereof; and,
FIG. 6 is a bottom plan view thereof.
The broken lines in the figures are for the purpose of showing environmental structure and form no part of the claimed design.

1 Claim, 5 Drawing Sheets

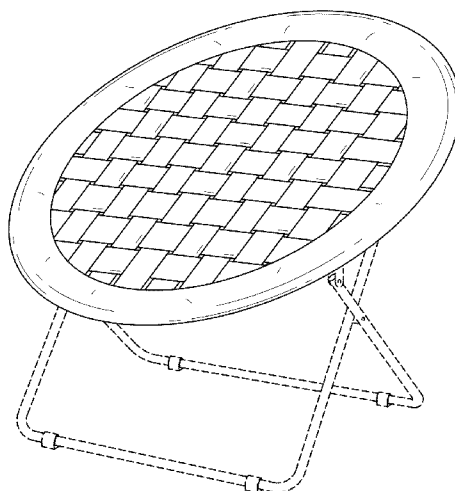

(56)

References Cited

U.S. PATENT DOCUMENTS

D168,993 S	3/1953	Gould	5,494,333 A	2/1996	Wilson
D169,338 S	4/1953	Risley	5,496,094 A	3/1996	Schwartzkopf et al.
2,649,901 A	8/1953	Johnson	5,499,857 A	3/1996	Lynch, Jr.
D171,176 S	12/1953	Yellen	5,522,642 A	6/1996	Herzog
D171,265 S	1/1954	Phillips	D372,366 S	8/1996	Frinier
D171,610 S	3/1954	Morrison	5,580,129 A	12/1996	Findlay
2,684,709 A	7/1954	Schawinsky	D380,306 S	7/1997	Lin
2,691,410 A	10/1954	Boucher	D382,126 S	8/1997	Lee
2,712,349 A	7/1955	LeVoir	D382,414 S	8/1997	Lee
2,713,890 A	7/1955	Mack	5,718,473 A	2/1998	Lynch, Jr.
2,723,712 A	11/1955	Yellen	5,848,822 A	12/1998	Wu
2,727,564 A *	12/1955	Gruber	5,893,605 A	4/1999	Chang
		A47C 4/24	D411,387 S	6/1999	Zheng
		297/239	D411,693 S	6/1999	Navone
2,733,755 A	2/1956	Boucher	5,979,976 A	11/1999	Ferencik
D177,783 S	5/1956	Witty	5,984,406 A	11/1999	Lee
2,763,318 A	9/1956	Bertoia	6,045,177 A	4/2000	Grace
D178,900 S *	10/1956	O'Neill	6,056,354 A	5/2000	Tseng
D179,376 S	12/1956	Breed	6,082,813 A	7/2000	Chen
D180,210 S	4/1957	Uretsky	6,095,607 A	8/2000	Wenzel
D181,995 S	1/1958	Odor, Jr.	6,112,757 A	9/2000	Tseng
D183,743 S	10/1958	Howell, Jr.	D431,382 S	10/2000	Eloge et al.
D184,202 S	12/1958	Yuen	D432,325 S	10/2000	Zheng et al.
2,902,084 A	9/1959	Stevens	D432,823 S	10/2000	Zheng
2,916,744 A	12/1959	May	D433,244 S	11/2000	Zheng
2,930,430 A	3/1960	Bloom	D433,574 S	11/2000	Zheng
D197,599 S	3/1964	Moore	6,149,238 A	11/2000	Tsai
3,123,396 A	3/1964	Searle	6,179,374 B1	1/2001	Tang
3,124,387 A	3/1964	MacLaren	6,209,951 B1	4/2001	Han
3,136,272 A	6/1964	Sprigman	6,231,119 B1	5/2001	Zheng
3,180,685 A	4/1965	Rogalski	6,237,993 B1	5/2001	Zheng
3,635,520 A	1/1972	Roher et al.	6,238,001 B1	5/2001	Yoran
3,656,808 A	4/1972	Chang	6,241,311 B1	6/2001	Zheng
3,694,030 A	9/1972	Grosfillex	6,247,748 B1	6/2001	Zheng
D228,593 S	10/1973	Chang	6,264,271 B1	7/2001	Munn et al.
3,767,192 A	10/1973	Eriksson	6,283,046 B1	9/2001	Tseng
3,838,883 A	10/1974	Machen	6,296,304 B1	10/2001	Zheng
3,941,416 A	3/1976	Uchida	6,302,479 B1	10/2001	Zheng
D241,290 S	9/1976	Walker	6,312,343 B1	11/2001	Cho
D244,975 S	7/1977	Steinberger	6,322,138 B1	11/2001	Tang
4,045,045 A	8/1977	Boucher et al.	6,332,646 B1	12/2001	Tseng
4,047,752 A	9/1977	Rohr	6,354,657 B1	3/2002	Nelson et al.
4,105,244 A	8/1978	Colby	6,364,411 B1	4/2002	Zheng
4,118,065 A	10/1978	Watkins	6,371,553 B1	4/2002	Tang
4,193,630 A	3/1980	Steele	D456,628 S	5/2002	Satoshi
D256,409 S *	8/1980	Wilson	6,382,715 B1	5/2002	Tang
4,231,582 A	11/1980	Moss	6,382,729 B1	5/2002	Wu
4,258,951 A	3/1981	Groom	6,402,230 B1	6/2002	Tang
4,290,643 A	9/1981	Logan, 3rd	D460,280 S	7/2002	Fox
D262,674 S	1/1982	Logan, 3rd	6,419,311 B1	7/2002	Tang
D264,405 S	5/1982	Adkinson	6,447,057 B1	9/2002	Chen
D267,057 S	11/1982	Koehm	6,454,348 B1	9/2002	Wu
D270,557 S	9/1983	Williams	6,488,331 B2	12/2002	Chen
4,421,356 A	12/1983	Singer	6,494,530 B1	12/2002	Zheng
4,514,009 A	4/1985	Vanderminde et al.	D468,939 S	1/2003	Zheng
4,605,261 A	8/1986	Lee	6,505,885 B1	1/2003	Tang
D287,909 S	1/1987	Weiss	6,547,322 B2	4/2003	Marx
4,652,047 A	3/1987	Chan	6,554,717 B2	4/2003	Cho
D290,557 S	6/1987	Salvati et al.	D475,860 S	6/2003	Yang
4,671,566 A	6/1987	Knapp et al.	6,601,912 B1	8/2003	Chen
4,685,725 A	8/1987	Helfrich	6,607,240 B2	8/2003	Zheng
D292,048 S	9/1987	Shaffer	6,629,722 B1	10/2003	Tang
4,715,650 A	12/1987	Berman et al.	6,634,705 B1	10/2003	Zheng
4,717,201 A	1/1988	Barras	6,637,811 B2	10/2003	Zheng
4,789,123 A	12/1988	Mattsson	6,644,731 B2	11/2003	Tang
4,826,241 A	5/1989	Barras	6,669,281 B1	12/2003	Huang
4,867,505 A	9/1989	Parker	6,682,135 B2	1/2004	Zheng
4,889,383 A	12/1989	Jones	D486,310 S	2/2004	Goldy
4,934,638 A	6/1990	Davis	6,698,827 B2	3/2004	Le Gette et al.
D310,605 S	9/1990	Kwon	6,702,371 B2	3/2004	Zheng
5,058,950 A	10/1991	Mann	6,715,824 B2	4/2004	Zheng
5,176,393 A	1/1993	Robertson et al.	6,736,450 B2	5/2004	Miyagi
5,246,265 A	9/1993	Nagan et al.	6,755,462 B2	6/2004	Zheng
5,320,404 A	6/1994	Le Gal	6,779,838 B2	8/2004	Chang
5,335,967 A	8/1994	Vanderminde, Sr.	6,814,403 B2	11/2004	Zheng
D352,623 S	11/1994	McGuire	6,817,661 B2	11/2004	Zheng
			6,817,671 B1	11/2004	Zheng
			6,820,927 B2	11/2004	Isom et al.
			6,824,207 B1	11/2004	Lin

(56)

References Cited

U.S. PATENT DOCUMENTS

6,824,208 B2	11/2004	Zheng	D711,132 S	8/2014	Christakos et al.	
6,824,210 B2	11/2004	Zheng	D711,133 S	8/2014	Christakos et al.	
D499,258 S	12/2004	Tseng	D711,134 S	8/2014	Christakos et al.	
D500,605 S	1/2005	Schmidt et al.	D711,135 S	8/2014	Christakos et al.	
6,840,573 B1	1/2005	Yao	D711,136 S	8/2014	Christakos et al.	
6,840,574 B1	1/2005	Wu	D711,137 S	8/2014	Christakos et al.	
6,848,740 B1	2/2005	Reese	D711,138 S	8/2014	Christakos et al.	
D503,554 S	4/2005	Kay	D711,139 S	8/2014	Christakos et al.	
6,877,814 B2	4/2005	Lin	D711,140 S	8/2014	Christakos et al.	
6,883,862 B1	4/2005	Yao	D711,141 S	8/2014	Christakos et al.	
6,899,383 B2	5/2005	Hwang	D711,142 S	8/2014	Christakos et al.	
D507,892 S	8/2005	Zheng	D711,143 S	8/2014	Christakos et al.	
6,926,355 B2	8/2005	Le Gette et al.	D711,144 S	8/2014	Christakos et al.	
6,926,356 B2	8/2005	Chen	D711,145 S	8/2014	Christakos	
6,932,425 B1	8/2005	Tseng	D711,148 S	8/2014	Christakos	
6,938,951 B1	9/2005	Tseng	D711,149 S	8/2014	Christakos	
6,957,852 B1	10/2005	Hsieh	D711,150 S	8/2014	Christakos	
D512,233 S	12/2005	Bongaerts	D711,151 S	8/2014	Christakos	
D515,830 S	2/2006	Zheng	D712,185 S	9/2014	Akkad	
6,997,634 B2	2/2006	Zheng	D713,191 S	9/2014	Akkad	
7,000,983 B1	2/2006	Tsai	D716,574 S	11/2014	Akkad	
D516,825 S	3/2006	Zheng	D718,546 S	12/2014	Christakos	
D516,826 S	3/2006	Zheng	D718,547 S	12/2014	Christakos	
D517,819 S	3/2006	Zheng	D718,548 S	12/2014	Shinall	
7,011,372 B1	3/2006	Hsieh	D718,549 S	12/2014	Akkad	
7,011,374 B1*	3/2006	Hsieh	D720,550 S	1/2015	Akkad	
		A47C 7/282 297/452.13	D720,551 S	1/2015	Mueller	
			8,955,904 B1	2/2015	Zhu	
			D731,803 S *	6/2015	Christakos	D6/368
			D737,587 S *	9/2015	Akkad	D6/368
7,017,985 B2	3/2006	Chen	2002/0024240 A1	2/2002	Chen	
D522,263 S	6/2006	Hart	2002/0043822 A1	4/2002	Choi et al.	
7,073,852 B1	7/2006	Zheng	2002/0074834 A1	6/2002	Summar et al.	
D528,317 S	9/2006	Tseng	2002/0183128 A1	12/2002	Cho	
7,100,877 B2	9/2006	Bourke et al.	2003/0006632 A1	1/2003	Ku	
7,100,975 B1	9/2006	Zheng	2003/0015892 A1	1/2003	Wu	
D529,304 S	10/2006	Le Gal	2003/0020304 A1	1/2003	Zheng	
D529,728 S	10/2006	Le Gal	2003/0052518 A1	3/2003	Zheng	
D530,112 S	10/2006	Wilson et al.	2003/0057741 A1	3/2003	Zheng	
7,140,689 B2	11/2006	Zheng	2003/0057747 A1	3/2003	Johnston	
7,144,078 B2	12/2006	Hsieh	2003/0060309 A1*	3/2003	Smith, IV	A63B 69/00 473/431
7,178,864 B2	2/2007	Hsieh				
7,219,955 B2	5/2007	Lu et al.	2003/0094836 A1	5/2003	Chen	
7,229,128 B2	6/2007	Lee	2003/0111872 A1	6/2003	Zheng	
7,229,131 B2	6/2007	Chen	2003/0111874 A1	6/2003	Zheng	
7,264,245 B2	9/2007	Cho	2003/0127885 A1	7/2003	Tang	
D554,873 S	11/2007	Ma	2003/0234561 A1	12/2003	Zheng	
D555,378 S	11/2007	Tsai	2004/0007903 A1	1/2004	Chang	
7,328,940 B2	2/2008	Zheng	2004/0036323 A1	2/2004	Hwang	
7,396,073 B2	7/2008	Zheng	2004/0066075 A1	4/2004	Yeh	
7,404,601 B2	7/2008	Chen	2004/0094996 A1	5/2004	Zheng	
7,441,287 B2	10/2008	Zheng	2004/0094997 A1	5/2004	Zheng	
7,600,810 B2	10/2009	Chen et al.	2004/0113476 A1	6/2004	Chang	
D607,222 S	1/2010	Bassam et al.	2004/0130190 A1	7/2004	Zheng	
D608,104 S	1/2010	Vonnegut	2004/0135405 A1	7/2004	Zheng	
7,648,421 B2	1/2010	Yoon	2004/0232740 A1	11/2004	Enge	
7,878,585 B2	2/2011	Salisbury	2004/0245810 A1	12/2004	Tseng	
7,938,489 B2	5/2011	Nazari	2005/0077758 A1	4/2005	Reese	
D649,800 S	12/2011	Lievore et al.	2005/0088018 A1*	4/2005	Yao	A47C 4/24 297/16.1
D656,326 S	3/2012	Soewondo				
D661,360 S	6/2012	Campanaro et al.				
8,282,509 B1	10/2012	Michaelson et al.	2005/0236873 A1	10/2005	Edward	
D677,920 S	3/2013	Christakos	2005/0248202 A1	11/2005	Zheng	
D681,970 S	5/2013	Christakos	2006/0186711 A1	8/2006	Phipps	
D683,156 S	5/2013	Christakos	2006/0249991 A1*	11/2006	Hsieh	A47C 4/48 297/16.1
D688,057 S	8/2013	Christakos				
D691,384 S	10/2013	Akkad	2007/0029846 A1	2/2007	Cohen	
D703,460 S	4/2014	Kreuzer et al.	2007/0102974 A1	5/2007	Chen	
D709,708 S	7/2014	Tseng	2007/0187998 A1	8/2007	Chen	
D710,120 S	8/2014	Tseng	2007/0200395 A1	8/2007	Zheng	
D710,136 S	8/2014	Wu	2007/0267901 A1	11/2007	Zheng	
D710,137 S	8/2014	Wu	2008/0224504 A1	9/2008	Fargason	
D710,138 S	8/2014	Wu	2008/0231088 A1	9/2008	Zheng	
D710,639 S	8/2014	Wu	2010/0164256 A1	7/2010	Salisbury	
D711,128 S	8/2014	Christakos et al.	2010/0231015 A1	9/2010	Lundeen	
D711,129 S	8/2014	Christakos et al.	2011/0043003 A1*	2/2011	Akkad	A47C 4/24 297/16.1
D711,130 S	8/2014	Christakos et al.				
D711,131 S	8/2014	Christakos et al.				

(56)

References Cited

U.S. PATENT DOCUMENTS

FOREIGN PATENT DOCUMENTS

CN	2117779	U	10/1992
CN	2137107	Y	6/1993
CN	2179041	Y	10/1994
CN	2188885	Y	2/1995
CN	2196945	Y	5/1995
CN	1139537	A	1/1997
CN	2326083	Y	6/1999
CN	2328266	Y	7/1999
CN	2339063	Y	9/1999
CN	2349884	Y	11/1999
CN	2367154	Y	3/2000
EP	139306	A1	5/1985
EP	997090	A1	5/2000
FR	2833824	A1	6/2003
FR	2837081	A1	9/2003
GB	599760	A	3/1948
GB	2022405	A	12/1979
GB	2025213	A	1/1980
GB	2331233	A	5/1999
JP	38-12532		6/1938
JP	50123508	A	9/1975
JP	51127856	A	11/1976
JP	55120347	A	9/1980

JP	2001070077	A	3/2001
JP	2002165667	A	6/2002
JP	2002233429	A	8/2002
JP	2002360371	A	12/2002
JP	2004105557	A	4/2004
WO	2004021835	A1	3/2004

OTHER PUBLICATIONS

U.S. Appl. No. 29/510,671 by Akkad, filed Dec. 2, 2014.
 U.S. Appl. No. 29/510,672 by Akkad, filed Dec. 2, 2014.
 U.S. Appl. No. 29/506,379 by Akkad, filed Oct. 15, 2014.
 U.S. Appl. No. 29/510,668 by Akkad, filed Dec. 2, 2014.
 Office Action Issued Oct. 18, 2010 in U.S. Appl. No. 12/544,256.
 U.S. Appl. No. 13/570,472 by Akkad, filed Aug. 9, 2012.
 U.S. Appl. No. 29/434,983 by Akkad, filed Oct. 18, 2012.
 Office Action issued Jan. 28, 2014 in CA Application No. 2,791,594.
 Office Action issued Sep. 20, 2013 in U.S. Appl. No. 13/570,472 by Akkad.
 Office Action issued Jan. 14, 2014 in U.S. Appl. No. 13/570,472 by Akkad.
 U.S. Appl. No. 29/483,471 by Akkad, filed Feb. 28, 2014.
 U.S. Appl. No. 29/483,488 by Akkad, filed Feb. 28, 2014.
 U.S. Appl. No. 29/478,866 by Akkad, filed Jan. 9, 2014.
 U.S. Appl. No. 29/493,606 by Akkad, filed Jun. 11, 2014.
 U.S. Appl. No. 29/493,607 by Akkad, filed Jun. 11, 2014.

* cited by examiner

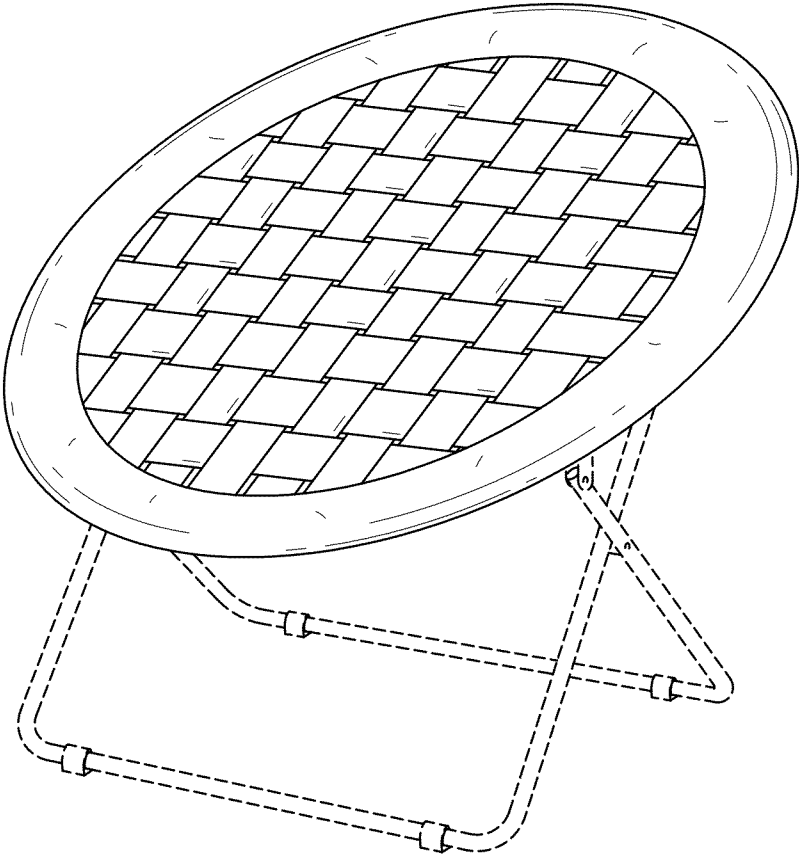

Fig. 1

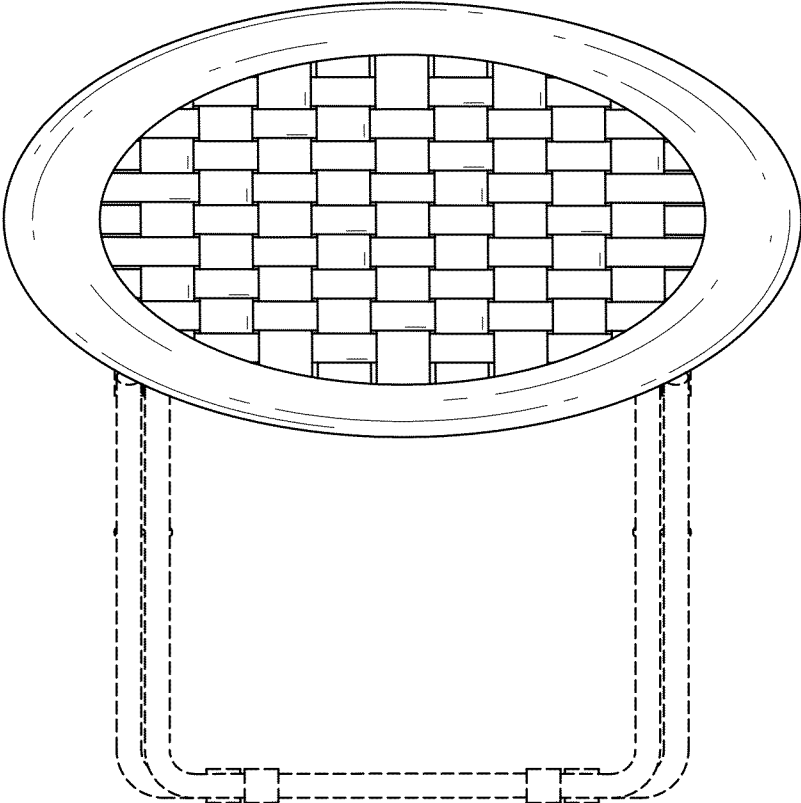

Fig. 2

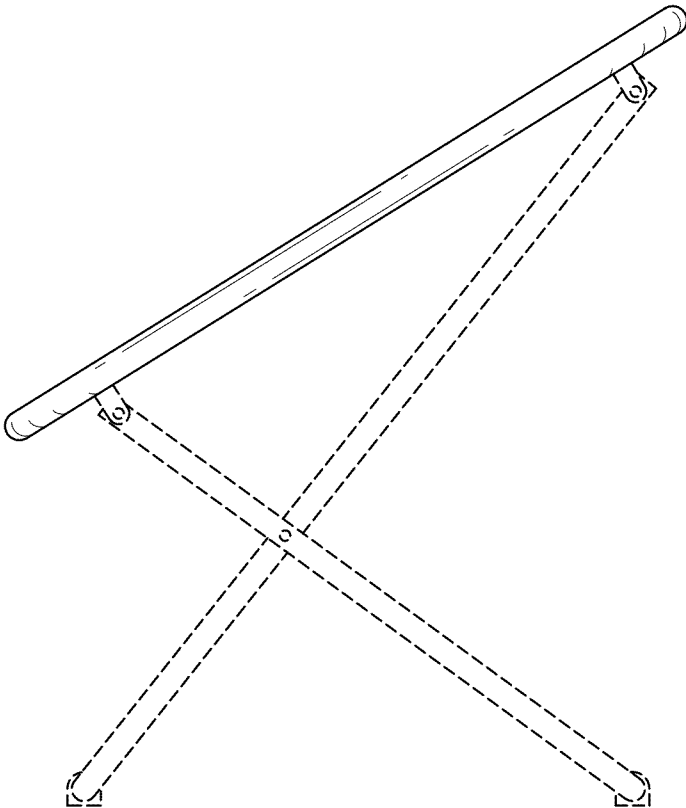

Fig. 3

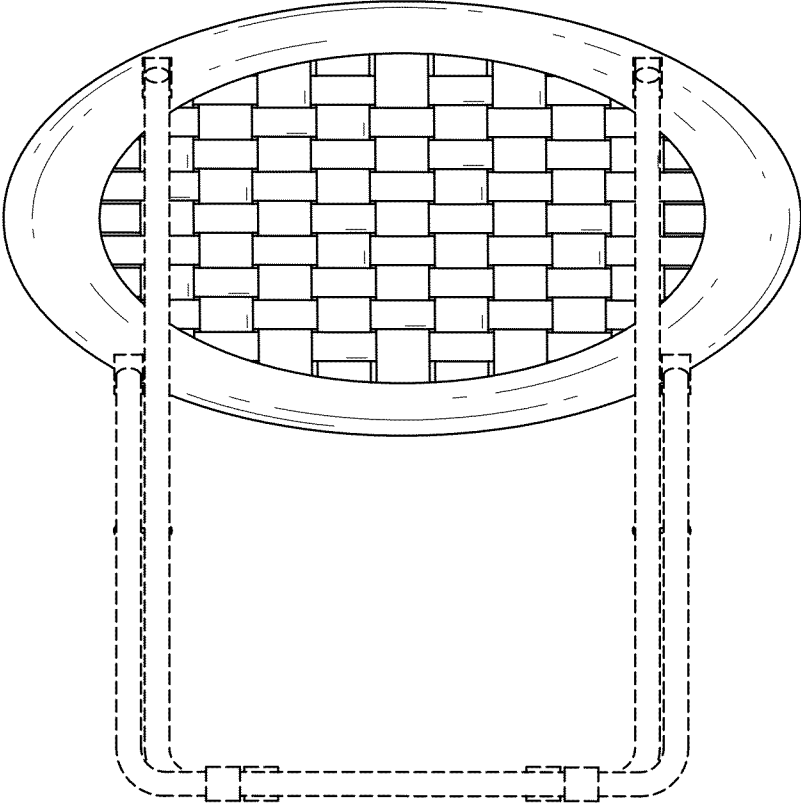

Fig. 4

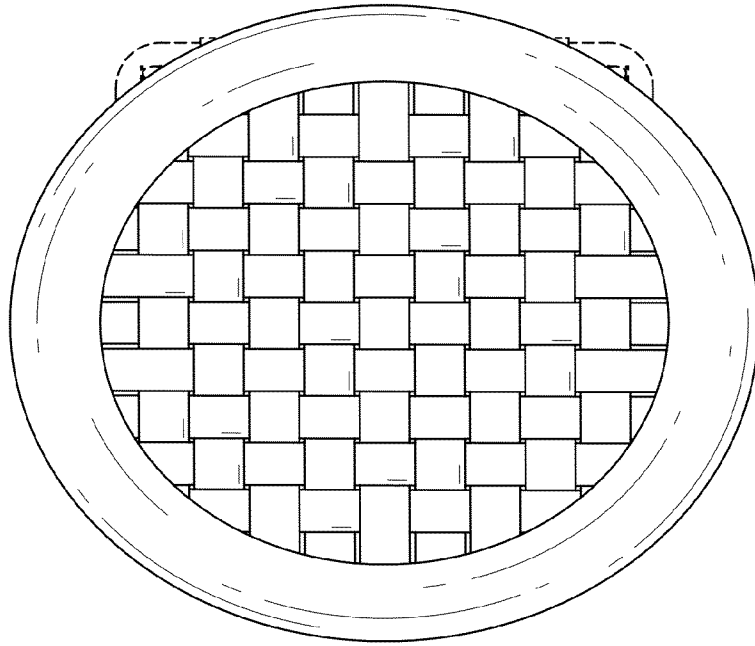

Fig. 5

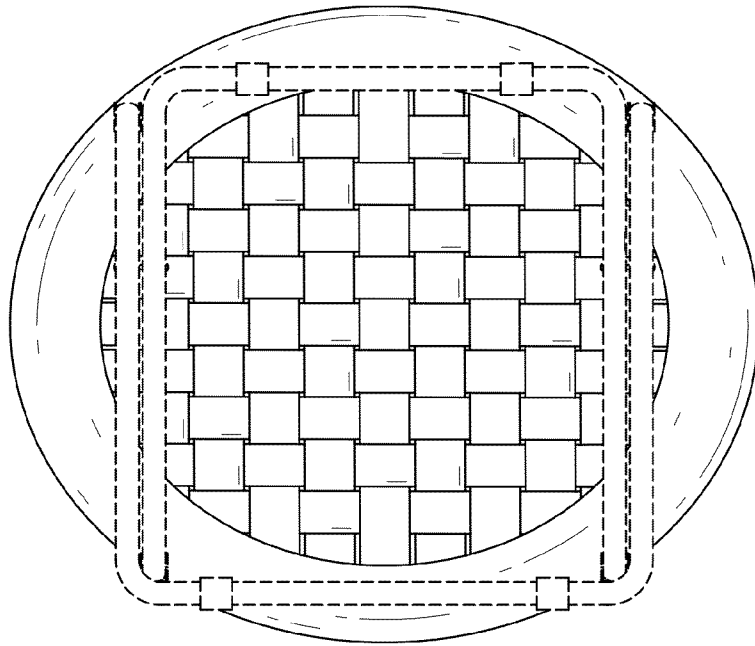

Fig. 6