

F. SCOTT.  
 DOOR OPENING AND CLOSING MECHANISM.  
 APPLICATION FILED APR. 29, 1908.

925,956.

Patented June 22, 1909.

4 SHEETS—SHEET 1.

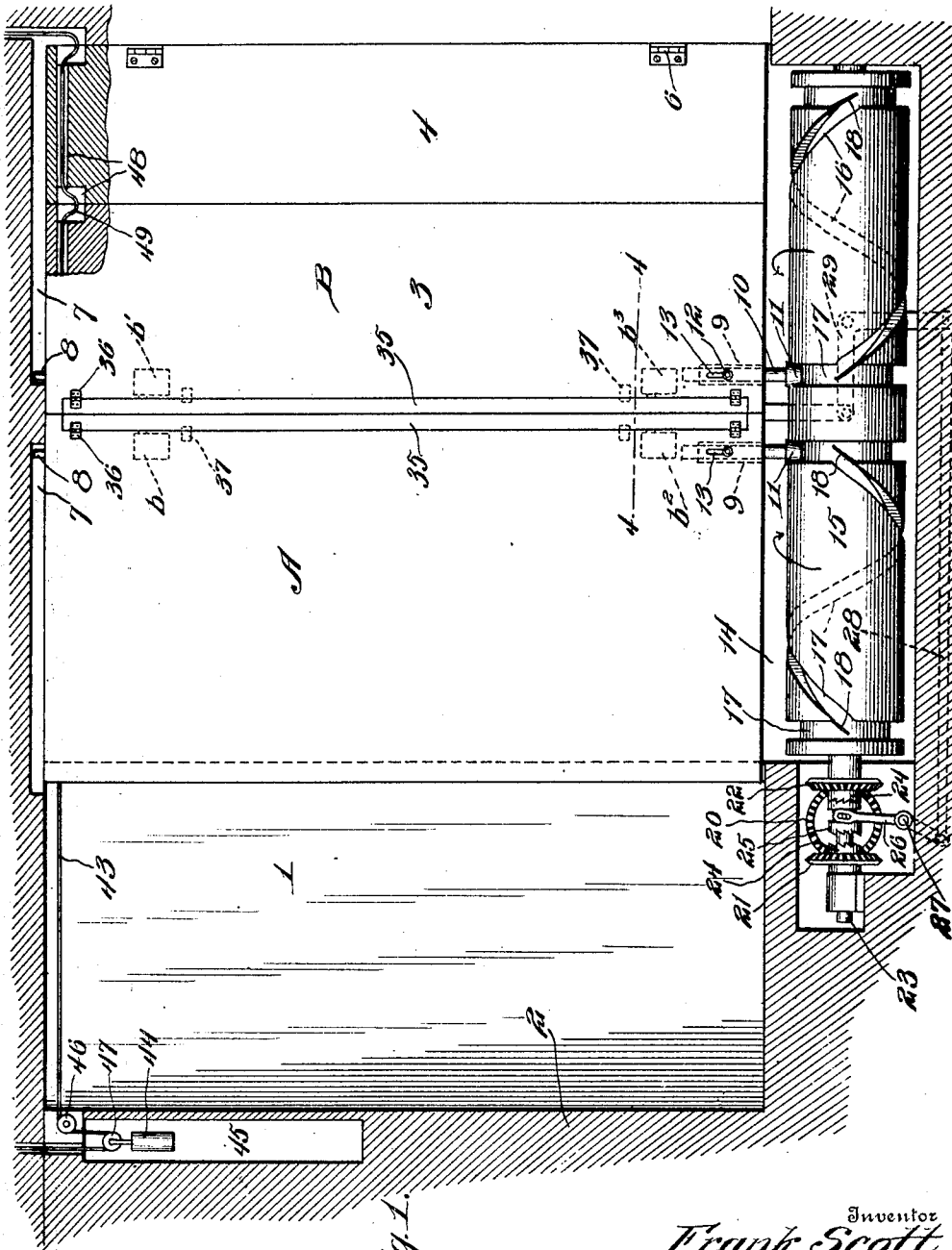

Fig. 1.

Witnesses

Louis R. Heinrichs  
 et Bradway.

Inventor  
 Frank Scott

334 Victor J. Evans  
 Attorney

F. SCOTT.  
 DOOR OPENING AND CLOSING MECHANISM.  
 APPLICATION FILED APR. 29, 1908.

925,956.

Patented June 22, 1909.

4 SHEETS—SHEET 2.

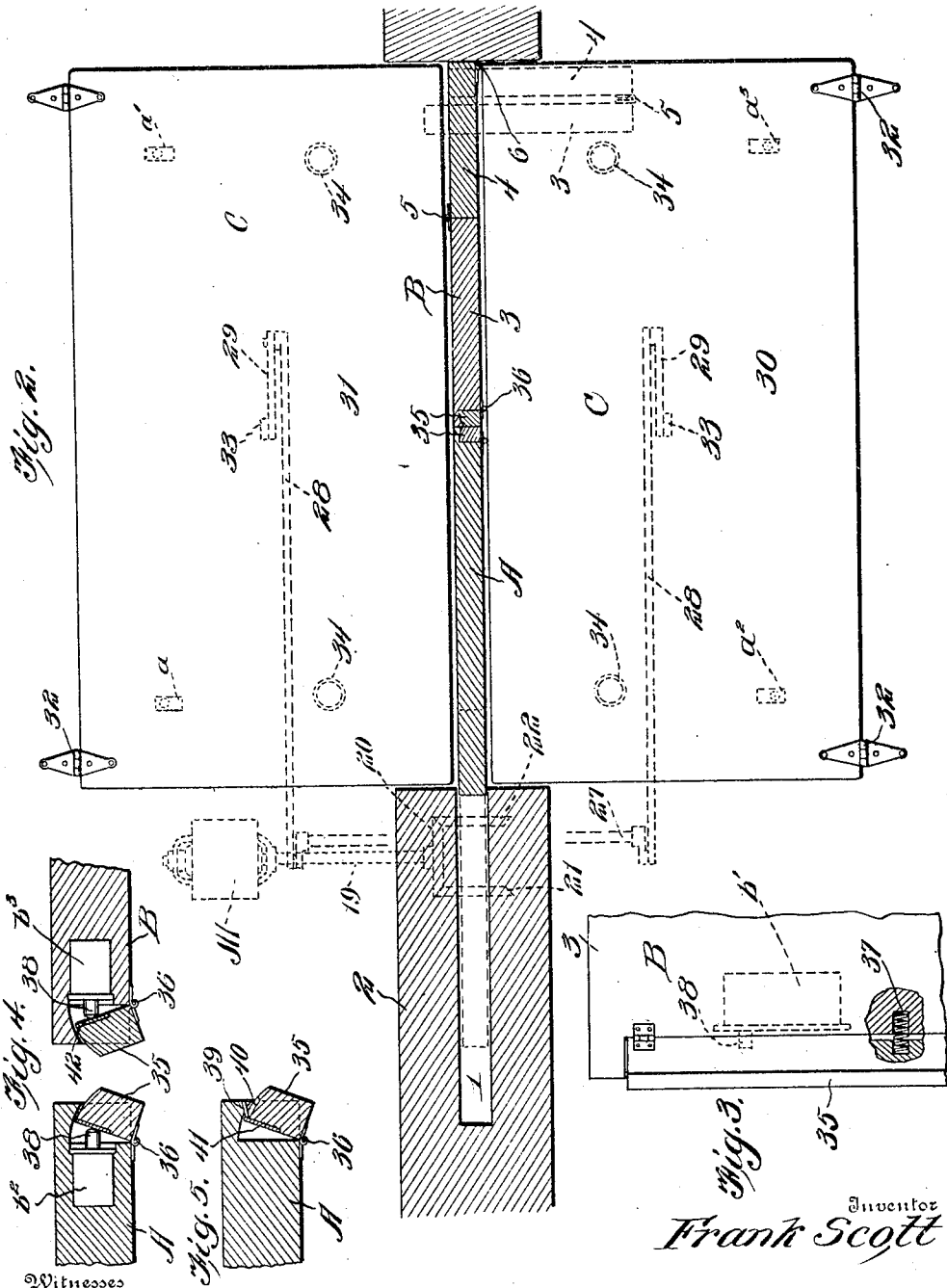

Witnesses  
 Louis S. Heinrichs  
 C. Bradway

Inventor  
 Frank Scott  
 By Victor J. Evans  
 Attorney

F. SCOTT.  
 DOOR OPENING AND CLOSING MECHANISM.  
 APPLICATION FILED APR. 29, 1908.

925,956.

Patented June 22, 1909.

4 SHEETS—SHEET 3.

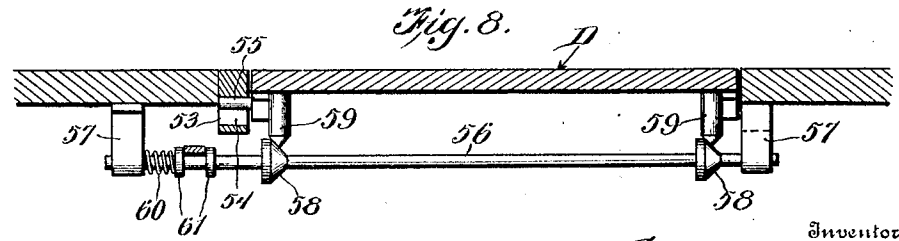
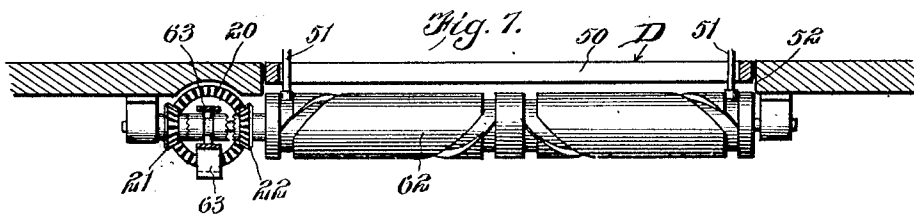
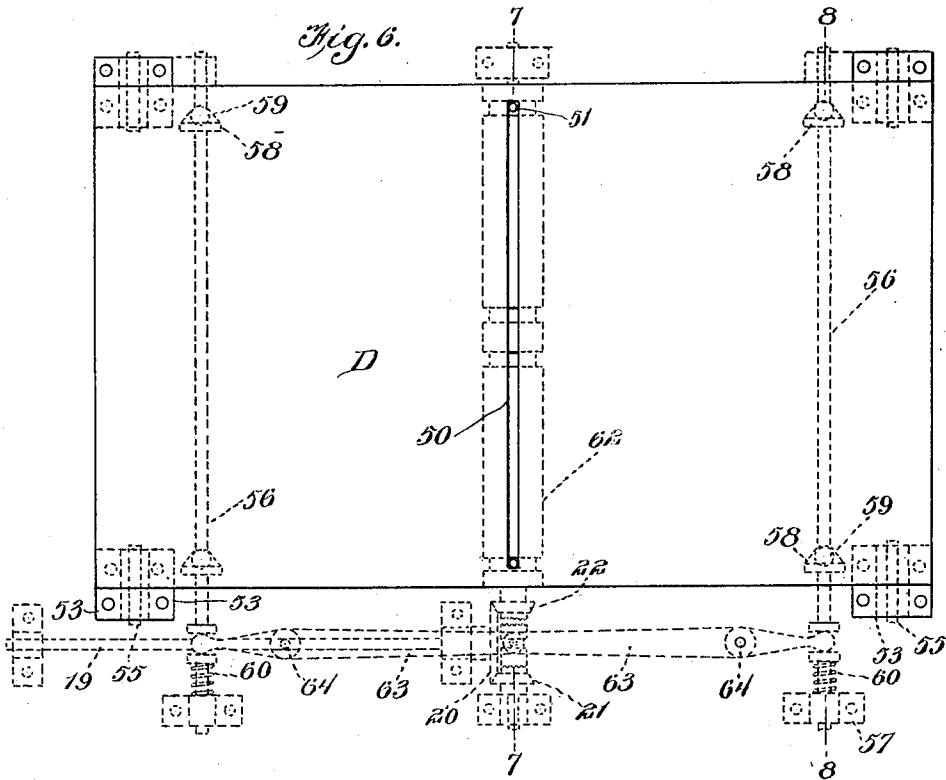

Inventor  
*Frank Scott*

Witnesses  
*Louis P. Heinrichs*  
*C. Broadway*

Attorney  
*Victor J. Evans*

F. SCOTT.  
 DOOR OPENING AND CLOSING MECHANISM.  
 APPLICATION FILED APR. 29, 1908.

925,956.

Patented June 22, 1909.  
 4 SHEETS—SHEET 4.

*Fig. 9.*

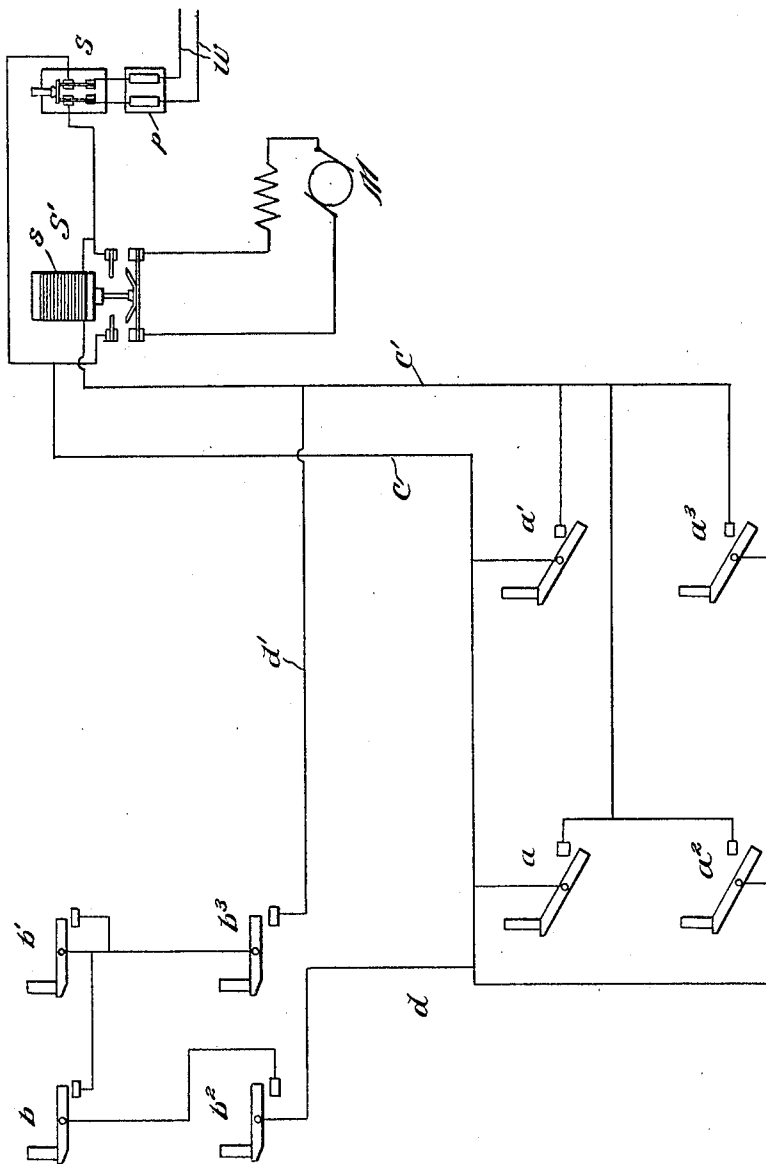

Witnesses

*Louis St. Heinrichs*  
*Ch. Bradley*

Inventor  
*Frank Scott*

By *Victor J. Evans*  
 Attorney

# UNITED STATES PATENT OFFICE.

FRANK SCOTT, OF ORBISONIA, PENNSYLVANIA, ASSIGNOR OF ONE-HALF TO JAMES B. SHIVELY, OF SHIPPENSBURG, PENNSYLVANIA.

## DOOR OPENING AND CLOSING MECHANISM.

No. 925,956.

Specification of Letters Patent.

Patented June 22, 1909.

Application filed April 29, 1908. Serial No. 429,924.

*To all whom it may concern:*

Be it known that I, FRANK SCOTT, a citizen of the United States, residing at Orbisonia, in the county of Huntingdon and State of Pennsylvania, have invented new and useful Improvements in Door Opening and Closing Mechanism, of which the following is a specification.

This invention relates to automatically-actuated doors of that type which are thrown open by suitable mechanism which is set into operation by the depressing of a platform, as by a person stepping upon the same and which is reversed to close the door when the person steps off the platform, the door being especially useful in hotel, store, and other large buildings where persons are constantly passing in and out.

The invention has for one of its objects to improve and simplify the construction and operation of apparatus of this character so as to be comparatively simple and inexpensive to manufacture, thoroughly reliable and efficient in use, and of substantial design.

The invention consists of a door-operating mechanism designed for use in connection with a single or double door and including electrically-actuated means, in connection with suitable mechanical means whereby the door will be thrown open as a person approaches and passes through the doorway and thrown closed after the person leaves the doorway.

The invention comprises an electric motor for operating the door-opening and closing element, which latter is driven forwardly or reversely by the motor through a clutch device that is controlled by a platform extending from opposite sides of the doorway so that as the platform is depressed, the clutch device will cause the said element to open the door and again close the door as the platform returns to normal position, the circuit of the motor being controlled by the movement of the platform.

The invention further comprises arranged switches in the motor circuit some of which are closed by the depressing of the platform, while the others are closed automatically immediately after the door starts to open, so that the motor circuit will be maintained until the door has completed its movement without the opening of the switches associated with the platform affecting the motor

circuit, thus preventing the door from ever stopping in an intermediate position.

With these objects in view and others, as will appear as the description proceeds, the invention comprises the various novel features of construction and arrangement of parts which will be more fully described hereinafter and set forth with particularity in the claims appended hereto.

In the accompanying drawings, which illustrate one of the embodiments of the invention, Figure 1 is a vertical sectional view of the apparatus showing the doors in closed position. Fig. 2 is a horizontal sectional view of the door showing the operating platform in plan view. Fig. 3 is a detail view of a portion of the door showing one of the door switches and the member for controlling the latter. Fig. 4 is a sectional view on line 4-4, Fig. 1. Fig. 5 is a detail sectional view showing the stop device for limiting the movement of the members on the doors for controlling the switches thereon. Fig. 6 is a plan view of a modified form of platform and clutch actuating mechanism. Figs. 7 and 8 are sectional views on lines 7-7 and 8-8, Fig. 6, respectively. Fig. 9 is a diagrammatic view of the circuit connections.

Similar reference characters are employed to designate corresponding parts throughout the several views.

In the present instance, I have elected to illustrate the invention as applied to a double door, the section A, of which is slidably mounted to move in and out of a socket 1 in the wall 2 at one side of the doorway, while the section B is composed of two parts 3 and 4 connected together by hinges 5 and hingedly-attached to the door frame by hinges 6 so as to open and close by a folding movement. It is to be understood, however, that the invention can be carried out in connection with a single door either of the sliding or foldable type. The doorway has horizontally-extending grooves 7 into which project pins 8 rising from the tops of the door sections so as to steady the doors during the opening and closing movements. Arranged in the doors are vertical sleeves 9 at the inner lower corner of each section and in these sleeves are slidably mounted bolts 10 that carry at their lower ends rollers 11 and attached to the bolts are finger pieces 12 which extend through vertical slots 13 in the

sleeves and door sections so that the bolts can be manipulated. In the floor under the door is a chamber 14 that contains a rotary element or roller 15 that has oppositely-disposed spiral grooves 16 in which the rollers 11 on the bolts 10 are adapted to run for opening or closing the door sections. The ends of each groove communicate with annular grooves 17 in which the bolts run when the door is fully opened or closed and the element 15 continues to rotate for any reason. To direct the bolts into the grooves 16 from the grooves 17, spring guards 18 are arranged at the ends of the grooves 16 and normally extend across the grooves 17, the said guards being arranged to yield to one side when the rollers 11 strike against the same from the rear in case the rotary element should continue to rotate through one or more revolutions.

The rotary element 15 for opening and closing the door is driven by an electric motor M that has its shaft 19 provided with a miter gear 20 that is constantly in mesh with miter gears 21 and 22 disposed on the shaft 23 of the element 15 so as to drive the latter in both directions. The hubs 24 of the miter gears 21 and 22 are formed into toothed clutch elements with which coöperates a sliding clutch element 25 that is feathered on the shaft 23 so that the said shaft can be driven by either miter gear 21, or 22. The sliding clutch element 25 is thrown into engagement with either miter gear by a lever 26 secured to a rock shaft 27. This rock shaft is connected by links 28 that are in turn connected with bell crank levers 29 that are actuated by a platform C arranged in the floor at opposite sides of the door. In the present instance, the platform is composed of two sections 30 and 31 that are attached at their outer corners to the floor by hinges 32 with their meeting ends coinciding with the door, and depending from the platform sections are arms 33 to which the bell crank levers 29 are connected. Disposed under the platform sections are springs 34 that hold the said sections flush with the floor and permit the platform to yield or depress when a person steps upon either section so as to throw in the clutch to connect the rotary element with the motor for opening the door. A person approaching the door from either side steps upon one platform section or the other and thereby automatically sets the door-opening mechanism into operation. When he passes from one platform section to the other, the latter will still hold the clutch in engagement with the forwardly-driven miter gear 21, and when the pressure is removed by the person leaving the platform after having passed through the doorway, the clutch will be automatically thrown into engagement with the reverse gear wheel 22 by the springs under the platform re-

storing the latter, and thus cause the door to be closed by the reverse rotation of the element 15.

In the motor circuit are arranged starting switches  $a, a^1, a^2, a^3$ , that are of any suitable design such as is known in the trade as the "Perkins" or "Diamond H" door push switch that are located under the platform sections, so that the depression of either of the latter will close the motor circuit for starting the latter, it being preferable to employ two switches for each platform section to insure the closing of the circuit. As soon as the door starts to open, additional switches are automatically closed so as to maintain the continuity of the motor circuit and thus prevent the motor from being cut out prematurely and leaving the door in open position, as would be the case as soon as the person stepped off the platform, since by so doing, the platform switches would immediately open. For this purpose, the circuit-maintaining switches  $b, b^1, b^2, b^3$ , are mounted on the door sections in such a manner that when the door is completely closed, these switches will be open and when the door starts to open, they will immediately close and thus preserve the continuity of the motor circuit. These circuit-maintaining switches are preferably of the same construction as those used under the platform and are set into the door sections at their meeting edges, as clearly shown in Figs. 1 and 4, and on each door section is a circuit-controlling member such as a strip 35 connected to its respective section by hinges 36 so as to swing outwardly when the door sections open, there being springs 37, Fig. 3, which urge the said strips outwardly. These strips bear upon the push buttons 38, Fig. 4, of the switches  $b, b^1, b^2, b^3$ , and hold such switches open when the strips are pressed inwardly and held in their normal position by the door sections when in closed position. During the initial part of the opening movement of the door, the members 35 swing outwardly, as shown in Fig. 4, and thus permit the maintaining switches to be connected in circuit, so that the continued running of the motor will be maintained until the door is again closed. The outward movement of the members 35 is limited by a stop 39 for each member, as shown in Fig. 5, that engages in a slot 40 of such member that bears against the metal plate 41 when the said member is fully opened. To prevent wear of the said members where the buttons 38 project, metal plates 42 are provided. The door sections are provided with grooves or channels for receiving the conductors leading to the switches  $b-b^3$ , the conductors being of the cord type such as used for portable lamps. The cord conductor 43, connected with switches on the door section A, is provided with a take-up device such as a

weight 44 which rises and falls in a chamber 45 in the wall 2 having the pocket 1, the cord passing over a fixed pulley 46 and a pulley 47 attached to the weight, so that as the door section A moves inwardly and outwardly, the weight will take up the sag. The cord conductor 48 for the switches in the door section B is sufficiently loose, as at 49, where the parts of the door section hinge so that the folding and unfolding of the door can be accomplished without strain on the conductor.

Referring to Fig. 6, S designates the main switch for connecting the motor circuit with the lead wires *w* of a suitable supply circuit, there being a protective device *p* such as fuses for preventing an overcharge of the motor circuit. The platform-actuated switches *a*—*a*<sup>3</sup> are connected in parallel with the wires *c*, *c*<sup>1</sup>, which lead to the switch S, and including in the wire *c*<sup>1</sup> is an automatic switch S<sup>1</sup> consisting of a solenoid *s* through which current passes when either pair of switches *a*, *a*<sup>1</sup>, *a*<sup>2</sup>, *a*<sup>3</sup>, are closed. Upon the energizing of the solenoid, the motor M is connected in circuit so as to drive the door-opening and closing device. As the door begins to open, all the circuit-maintaining switches *b*, *b*<sup>1</sup>, *b*<sup>2</sup>, *b*<sup>3</sup>, are automatically closed so that current will pass through a shunt circuit consisting of the wires *d*, *d*<sup>1</sup>, connected respectively with the wires *c*, *c*<sup>1</sup>, the said circuit-maintaining switches being connected in series with the wires *d*, *d*<sup>1</sup>. As long as the switches *b*—*b*<sup>3</sup> are closed, the motor will be driven in one direction or the other, according to which gear 21 or 22 is in mesh, so that the door will be moved to its extreme position, regardless of the condition of the switches *a*—*a*<sup>3</sup>.

The operation of the apparatus will be briefly described as follows. When a person approaches the doorway and treads upon either platform section, the latter is depressed and causes the motor circuit to be completed by the starting switches under the platform section that is depressed and at the same time the mechanical connection between such platform section and the clutch will connect the door-actuating element 15 with the motor. Assuming that the element 15 is rotated in a direction indicated by the arrow, the rollers 11 are brought into contact with guards 18 in the inner annular grooves 16, thus causing the door sections to move apart. As the door sections move apart, the members 35 spring outwardly to permit the circuit-maintaining switches on the doors to be connected in circuit with the motor. The continued rotation of the element 15 completely opens the door, and should the platform be held depressed for a longer period than is necessary to open the doors, the element 15 will continue to rotate, while the rollers 11 are in the outer annular

grooves 17. As soon as the person steps off the platform, the depressed section thereof will be automatically raised by its springs so as to reverse the clutch and connect the element 15 with the motor in such a manner as to rotate the element in the opposite direction, thereby moving the door sections closed. As long as either platform section is depressed, the circuit is completed through the starting switches and the maintaining switches, and as soon as the person steps off the platform, the maintaining switches alone complete the circuit. When the door sections have come together, the members 35 contact and are pressed inwardly so as to open the switches *b*—*b*<sup>3</sup> and thus cut the motor out of circuit.

Referring to the modified construction shown in Figs. 6 to 8, inclusive, D designates the platform which is made in one piece and extends from opposite sides of the door and is provided with a central slot 50 in which move the bolts 51 on the door sections. At the corners of the floor opening 52 in which the platform is disposed are fixed guides 53 having vertical slots 54 into which project horizontal pins 55 secured to the corners of the platform and disposed under the latter. These guides limit the downward movement of the platform and also insure against lateral displacement of the latter. Extending transversely to and disposed under the platform are longitudinally movable rods 56 slidably mounted at their ends in bearings 57, and on each rod are cones or wedges 58 with which engage pointed lugs 59 secured to the under side of the platform, so that when either end of the platform is depressed, the rod 56 immediately under the depressed end will be shifted longitudinally for the purpose of actuating the clutch device. The rod 56 is restored to normal position by a spring 60 pressing on one of the bearings 57 and one of the space collars 61.

Arranged under the middle of the platform and directly in line with the slot 50 thereof is the door-opening and closing element 62 substantially similar to the element 15 referred to in connection with Fig. 1, and equipped with a clutch device whereby the element 62 can be driven in forward or reverse direction by a uni-directional motor. The movable member 25 of the clutch device is connected with oppositely-disposed levers 63 mounted on fulcrums 64 and the outer ends of the levers engage between the collars 61 on the rods 56 at the ends of the platform. The springs 60 restore the levers to normal position and also restore the platform when a person steps off the same.

When a person steps on the platform, the approach end thereof is depressed whereupon the rod 56 is moved laterally so as to throw in the clutch and permit the motor to rotate the element 62 in a direction to open

the door sections, and as long as a person is on the platform the motor will continue to operate and upon leaving the platform the parts will be restored to normal position and the clutch reversed so as to cause the element 5 62 to return the door sections to closed position.

From the foregoing description, taken in connection with the accompanying drawings, 10 the advantages of the construction and of the method of operation will be readily apparent to those skilled in the art to which the invention appertains, and while I have described the principle of operation of the 15 invention, together with the apparatus which I now consider to be the best embodiment thereof, I desire to have it understood that the apparatus shown is merely illustrative, and that such changes may be made 20 when desired as are within the scope of the claims appended hereto.

Having thus described the invention, what I claim is:—

1. The combination of a door, a mechanism for opening and closing the same including an electric motor, a platform, switches for closing the circuit of the motor by the depression of the platform, a switch set into the door and connected in circuit with the 30 motor, a member on the door concealing the switch and arranged to hold the latter open when the door is closed, and means disposed between the door and member for moving the latter when the door is open to permit 35 the switch of the door to close to hold the motor circuit closed independently of the switch controlled by the platform.

2. The combination of a door, a member hingedly connected with the door adjacent 40 the free edge thereof, springs interposed between the door and member for urging the latter outwardly, means for limiting the outward movement of the member, a switch 45 mounted on the door and held open by the member while the door is closed and adapted to close simultaneously with the opening of the door, a mechanism for opening and closing the door including an electric motor, a circuit for the motor in which the said 50 switch is included, and means for closing the motor circuit for starting the motor to move the door sufficiently to permit the first-mentioned switch to close and maintain the motor circuit completed.

3. The combination of a sliding door, a switch carried thereby and arranged to be 55 opened when the door is closed, a flexible conductor connected with the switch and

concealed within the door, a motor controlled by the switch, means driven by the motor 60 for actuating the door, and a switch for connecting the motor in circuit prior to the closing of the first-mentioned switch.

4. The combination of a door mounted for sliding movement, a normally open switch 65 carried thereby and adapted to close automatically with the opening of the door, a flexible conductor connected with the switch and having one portion fixed and another portion carried by the door, a take-up device 70 acting on the conductor between the fixed portion thereof and the part connected with the door, a motor for opening and closing the door and controlled by the switch, and a second switch arranged to connect the motor 75 in circuit prior to the closing of the first-mentioned switch.

5. The combination of a door, a hinged member thereon and disposed vertically along the free edge thereof, means arranged 80 to throw the member outwardly when the door is opened, switches arranged on the door and disposed between the member and door to be opened and closed by the member, electrically actuated means for opening and 85 closing the door connected in circuit by the said switches, and a switch for connecting said last-mentioned means in circuit to give the door the necessary movement to permit 90 the members to close the first-mentioned switches.

6. The combination of a pair of door sections movable simultaneously, a rotatable element having oppositely-disposed grooves, 95 members on the door sections engaging in the grooves, a motor, a gearing between the motor and element, a clutch device for throwing in the gearing to rotate the element in either direction, a platform, a pair of 100 levers both engaging the clutch to shift the same, and separate means under the platform for shifting the levers when the platform is depressed, switches under the parts of the platform arranged to be closed by the depression of the latter, and switches carried 105 by the door sections and arranged to be closed at the initial part of the opening movement for maintaining the continuity of the motor circuit until the door sections are returned to closed position. 110

In testimony whereof I affix my signature in presence of two witnesses.

FRANK SCOTT.

Witnesses:

FRANK H. HARRISON,  
W. T. BELL.