



US005571178A

# United States Patent [19]

[11] Patent Number: **5,571,178**

**Ledergerber**

[45] Date of Patent: **Nov. 5, 1996**

## [54] BREAST IMPLANT INTRODUCER

[76] Inventor: **Walter J. Ledergerber**, 31 Morningwood, Laguna Niguel, Calif. 92677

[21] Appl. No.: **272,907**

[22] Filed: **Jul. 8, 1994**

### Related U.S. Application Data

[63] Continuation of Ser. No. 73,966, Jun. 8, 1993, abandoned, which is a continuation of Ser. No. 660,290, Feb. 22, 1991, abandoned.

[51] Int. Cl.<sup>6</sup> ..... **A61F 2/12**  
[52] U.S. Cl. .... **623/8; 623/66**  
[58] Field of Search ..... **623/66, 7, 8; 606/107, 606/108; 604/15-18, 311, 70, 72, 93**

### References Cited

#### U.S. PATENT DOCUMENTS

747,444	12/1903	Veine .....	604/59
977,004	11/1910	Grimm .....	604/59
2,053,868	9/1936	Grosso .....	128/20
2,509,241	5/1950	Mende .....	604/11
2,587,364	2/1952	Mitchell .....	604/59
2,754,823	7/1956	Miller .....	604/59
3,129,706	4/1964	Reynolds, Jr. ....	128/20

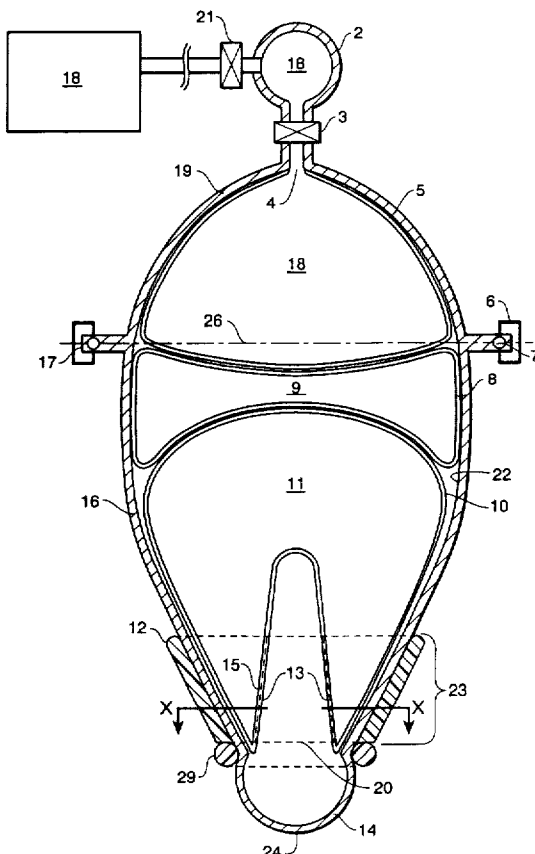
3,714,943	2/1973	Yanof et al. ....	604/70
3,853,125	12/1974	Clark et al. ....	604/70
4,035,850	7/1977	Cresswall .....	623/8
4,143,428	3/1979	Cohen .....	623/8
4,413,986	11/1983	Jacobs .....	604/14
4,421,508	12/1983	Cohen .....	604/70
4,610,659	9/1986	Friese .....	604/15 X
4,624,671	11/1986	Kress .....	623/8
4,798,584	1/1989	Hancock et al. ....	623/8
4,834,094	5/1989	Patton et al. ....	606/107
4,955,906	9/1990	Coggins et al. ....	623/8
5,123,905	6/1992	Kelman .	

Primary Examiner—David Isabella  
Attorney, Agent, or Firm—Lyon & Lyon

### [57] ABSTRACT

A tool and method for introducing an implant through an incision in a body utilizing a tube having a hole through which the implant is pressed. In the preferred embodiment, a two part tube has one open end and one closed end. The tube contains an expanding structure, for applying pressure on the implant, optionally a pressure transmitting structure, and an implant. The expanding structure is expanded optionally by gas or fluid filling the structure. Optionally, a collar is disposed around the tube near the opening, selectively covering and uncovering a cut-out in the tube which permits manipulation of the implant prior to insertion.

**18 Claims, 3 Drawing Sheets**



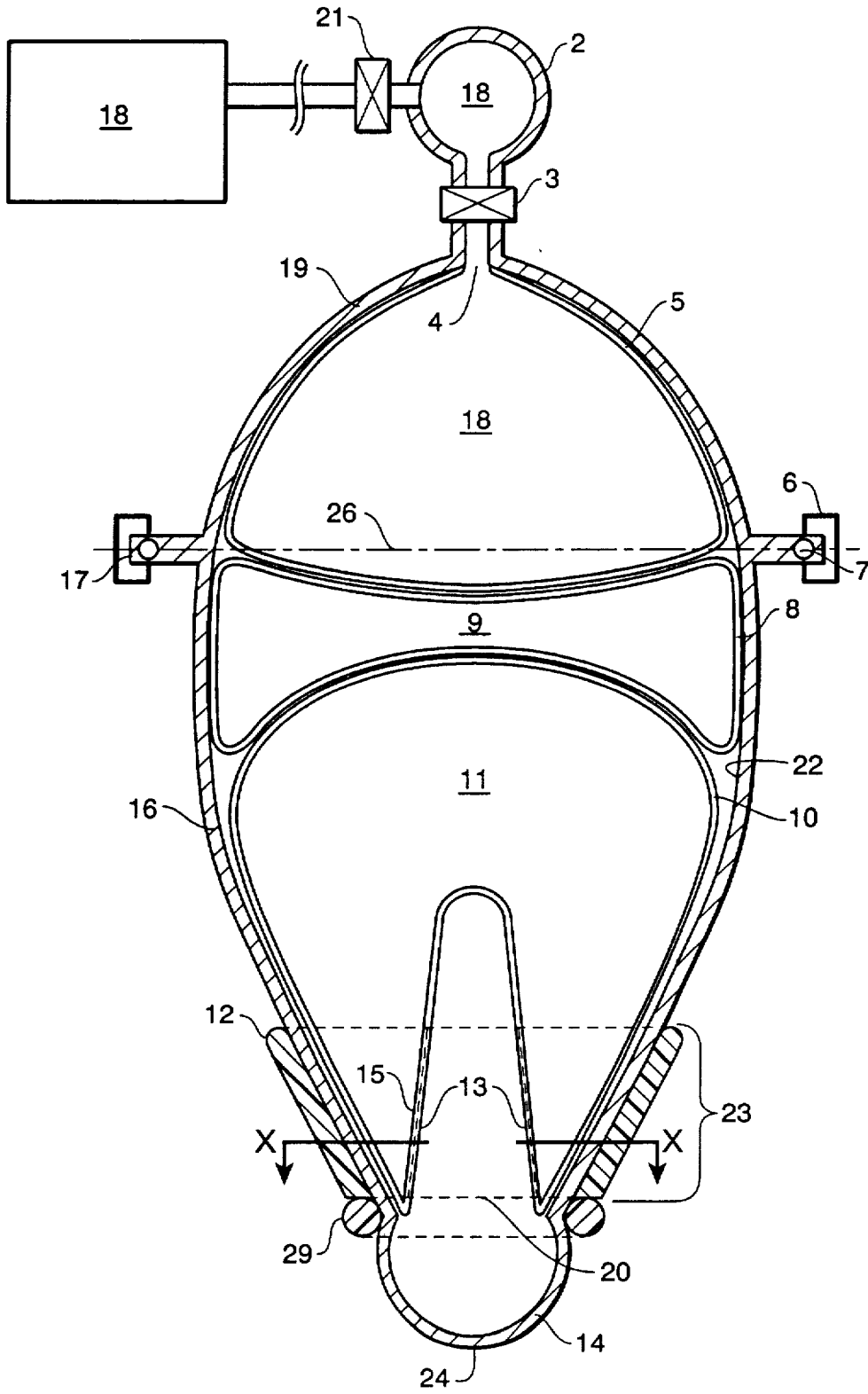


FIG. 1

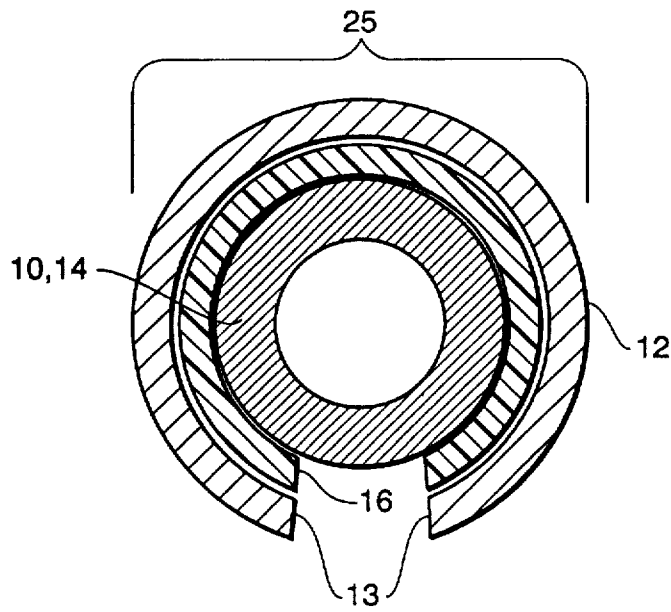


FIG. 2

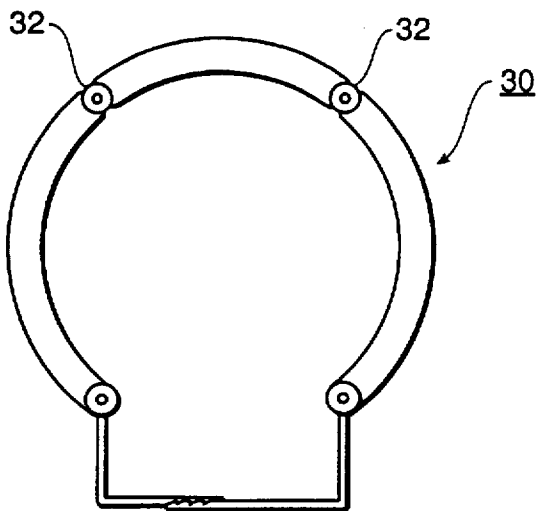


FIG. 3A

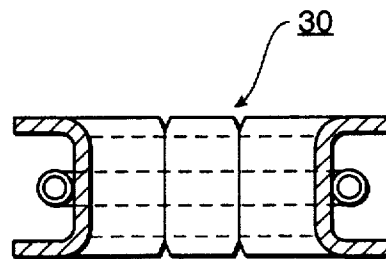
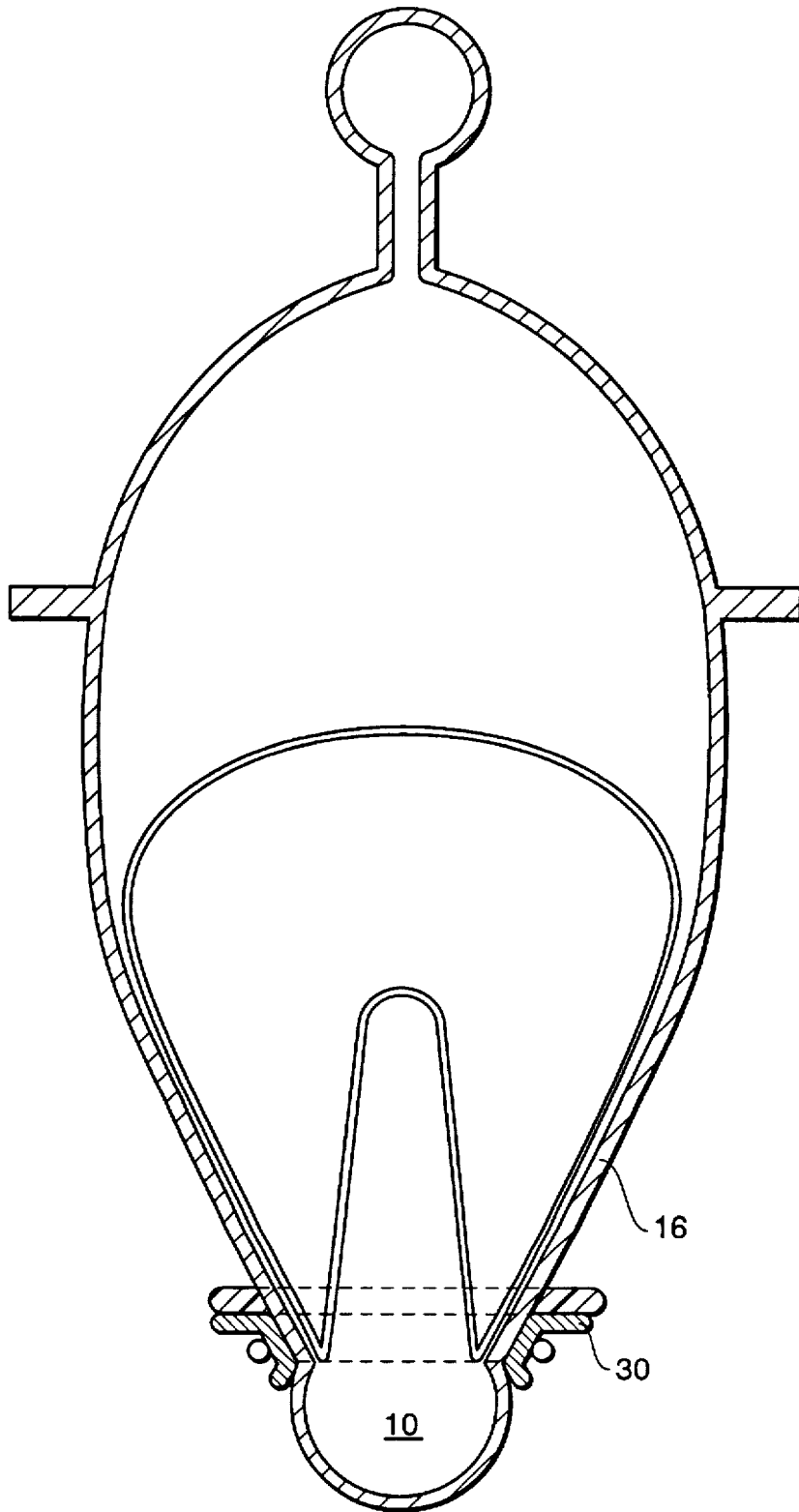


FIG. 3B



**FIG. 4**

**BREAST IMPLANT INTRODUCER**

This is a continuation of application Ser. No. 08/073,966, filed Jun. 8, 1993, now abandoned which is a continuation of application Ser. No. 07/660,290, filed Feb. 22, 1991, now abandoned.

**BACKGROUND OF THE INVENTION**

Reconstruction of the human breast involves introducing a fixed or changeable-volume sac-like silicone rubber structure into a body cavity surgically created to receive such an implant. The implants and coverings therefor are described, by way of illustration and not by limitation, in: Braumann U.S. Pat. No. 4,648,880; Hamas U.S. Pat. No. 4,531,244; and Ledergerber U.S. Pat. No. 4,955,907.

The usual skin incision is on the order of 3–8 centimeters in length and is stretched open with retractors to facilitate the introduction of the implant. By virtue of the displacement of fluid contained in the sac-like implant from outside of the body into the portion of the sac which has been introduced into the implant cavity, it is possible to gradually advance the membrane of the sac in pursuit of its fluid contents.

A number of sheet-like structures have been utilized to facilitate the introduction of implants into the body by enveloping the implant, with the primary object being to shape the fluid-filled sac for presentation to the retracted wound margins. The use of these sheet-like devices has not been of benefit in the hands of many practitioners of the art.

With advancing technology in breast implant design have come new designs exhibiting textured as opposed to smooth surfaces which are brought into intimate contact with the patient's tissues in the implanted state. A variety of textured surfaces for implants are disclosed in my issued U.S. Pat. No. 4,955,907, incorporated herein by reference. Since breast implants are usually placed into the body through incisions considerably smaller than the implant, it has always been a challenge to introduce them. With greatly increased friction at the interface between the surface of newer texturized implants and the wound margins (body tissue), it has become correspondingly more difficult to introduce these implants. Increased manipulation of both implants and patient tissue often results in trauma to both implants and patient tissue, thereby increasing the risk associated with the procedure both in terms of immediate consequences as well as delayed structural failure and the implications deriving therefrom. It has become a matter of some urgency to be able to introduce breast implants atraumatically.

**SUMMARY OF THE INVENTION**

A new breast implant introducer has as its object the alleviation of the difficulty of introducing breast implants and thus limiting greatly both damage to implants and trauma to patient tissues. In one of the preferred embodiments, a two-part rigid or flexible tube has one open end and one closed end. The two parts of the tube are held in apposition by closure means in order to create a single large cavity: the large cavity contains three soft structures (in the present preferred embodiment) including the breast implant which is extruded out of the open end of the tube upon increasing the pressure inside the topmost soft structure.

The topmost soft structure is expanded by introducing fluid or a gas by actuating the pump which may be connected to a fluid reservoir if fluid is utilized, or may simply be combined with a valve for gas intake and/or exhaust. The

expanding medium in the topmost soft structure applies pressure to the middle soft structure which in turn applies pressure to the lowest structure, the implant. The implant is extruded via the open end of the flexible or rigid structure. A soft or rigid collar assists in containing the implant within the neck of the tube during extrusion.

In another embodiment, a flexible tube has two open ends, one large enough to receive the implant, and the other small enough to insert the implant into the wound. In this embodiment, the tube is flexible, and permits direct user application of force through the flexible tube onto the implant. Optionally, a relatively rigid ring or partial annulus is affixed to the smaller opening. The ring or partial annulus may be placed partially inside the wound to stabilize the implant introducer tube.

A generally circular retractor adapted for use with the implant introducer is sized to be placed inside the wound when unexpanded, and to expand out, thereby facilitating implant introduction.

Accordingly, it is a principal object of this invention to provide a useful structure and method for introducing an implant through an incision in the human body.

It is a further object of the invention to provide for atraumatic introduction of an implant.

**BRIEF DESCRIPTION OF THE DRAWINGS**

The above objects and advantages of this invention will be more easily understood with reference to the following drawings and detailed descriptions.

FIG. 1 is a cross-section of a breast implant introducer.

FIG. 2 is a sectional view of FIG. 1 at "X—X".

FIG. 3 shows a retractor for use with the introducer, in plan view and side view.

FIG. 4 shows an introducer in combination with the retractor.

**DETAILED DESCRIPTION OF THE PREFERRED EMBODIMENTS AND THEIR OPERATION IN USE**

Referring to FIG. 1, a rigid tube 16 and a rigid cup 19 in which these structures may be hinged to each other to permit closure and thereby create a single joined structure, may have as its inner wall 22 a highly polished or otherwise treated surface with a very low coefficient of friction. A pump 2 with valves 3, 21 and possibly a fluid reservoir, are provided.

Two or three soft structures 5, 8, and 10 are enclosed within the combined tube and cup structure, one of which is an expansible structure 5 and another of which is the breast implant 10. A third structure 8 may be optionally interposed between the expansible structure 5 and the implant 10 for the purpose of limiting trauma to the implant 10 and also to provide for uniform transmission of pressure from the expansible structure to the implant.

Referring to FIG. 2, the collar 12 is positioned relative to the rigid or flexible tube 16 in such a way that a relief gap/void or cut-out in each superimposes on the other in such a way that the implant can be grasped or otherwise manipulated by the surgeon's fingers during the early "loading phase" during operation of the device. During active extrusion of the implant the collar 12 is rotated 180 degrees from its loading position in order to present a barrier to the transversely expanding portion of the implant.

3

Optionally, a relatively rigid ring or partial annulus **29** may be disposed at the end of the implant introducer which is used adjacent the body. The ring may be disposed inside the wound, and serve to stabilize the introducer during insertion of the implant.

In operation, with the rigid cup/tube combined structure open, the implant is introduced in the tube **16** portion and pushed toward the smaller open end **20** of the tube **16**. The surgeon grasps the leading edge **24** of the implant through the relief gap/void/cut-out **13** while advancing the leading edge **24** of the implant through the neck **23** and part way through the open end **20** of the tube **16**. A second soft structure **8** is placed on top of the implant **10** and thus positioned between the implant **10** and the expansible soft structure **5** in the rigid cup **19** portion of the combined cup/tube structure. The combined cup/tube structure is then closed and sealed by utilizing optional closure/locking means **6**. Pump **2** is actuated to expand the expansible soft structure **5** sufficient to exert pressure through the middle soft structure **8** onto the implant **10**. The collar **12** is turned 180 degrees in such a way that the body of the collar **25** presents a barrier to transverse expansion of that portion of the implant **10** positioned in the neck **23** of the tube **16**. Further expansion of the expansible structure **5** by filling with fluid or gas **18** forces the implant to be extruded via the opening **20** in the tube **16**. The leading lobe **14** of the implant is positioned directly over the incision through which it is to be introduced into the implant cavity of the patient. Additional actuation of the pump **2** completes extrusion of the implant **10**. During final extrusion the surgeon's hands stabilize the neck **23** and collar **12** as well as the cup **19** or pump **2** portions of the invented device.

Another embodiment of the device is that where the cup **19** and tube **16** are rigid and the expansible structure **5** is a rigid sliding piston-like element and where the middle structure **8** may be either a sac-like structure or a sliding piston-like structure.

Another embodiment of the device is that where the cup **19** and tube **16** are flexible and sheet-like and either joined as are the cup **19** and tube **16** above or joined by virtue of being made of the same piece of flexible material. In this embodiment the implant **10** is loaded into the device through the large opening at the end opposite the open extrusion end **20** exactly as described above. Extrusion of the implant **10** results upon closing the end through which the implant was loaded by twisting, folding, rolling, constricting, or otherwise closing and by applying and maintaining hand and digital pressure external to the flexible cup/tube combined structure while stabilizing the neck **23** as well as the closed end of the device with the surgeon's hands. The ring may be positioned inside the body cavity created to receive the implant. A preferred material of the ring—is a semi-dense biocompatible rubber compound. Preferred sheet-like materials for this embodiment include Gore-Tex (PTFEe, expanded polytetrafluoroethylene) as well as other materials exhibiting low coefficients of friction.

Preferred materials for the rigid embodiments of cup **19** and tube **16** as described above include teflon, nylon, polyethylene and other plastic polymers as well as metals including stainless steel, annealed glass, and others.

The preferred fluid **18** for filling of the expansible chamber **5** is normal saline solution. Other fluids may also be suitable.

One of the preferred gases **18** for filling the expansible chamber **5** is room air.

The preferred embodiment of the pump **2** described above may be a hand actuated pump. The position of the pump **2**

4

with respect to the rigid or flexible structures **19** and **16** described above is variable and dependent only upon an efficient design of the entire invented device.

An expansible chamber **5** in another embodiment may be comprised of a rigid cup **19** and an expansible membrane **26** positioned and fixed to a cross-sectional perimeter of the rigid cup as, for example, along the seam plane **17**.

Another preferred embodiment is that in which pressure is applied to implant **10** and structure **8** by a rigid or flexible metal or plastic piston which is advanced mechanically through the cup/tube combination along the long axis of the tube **19**.

In connection with any embodiment of this invention, it may be desirable to include the implant within a sheet of slippery material, such as Gore-Tex, for easing insertion of the implant. Once the implant and sheet are introduced into the body, the sheet may be removed.

FIG. **3** shows a self-retaining ring retractor for use in connection with the implant introducer of this invention. The retractor **30** is sized to be inserted into the wound when partially collapsed or folded, and then expanded to effect wound retraction for insertion of the implant. The retractor may be made of any suitable material, such as spring metal, or plastic or a dense rubber. It may be of one piece or may be segmented. Hinges **32** provide flexibility. A ratchet expansion device may be used to hold the retractor in an expanded state. As shown in FIG. **4**, optionally, the implant inserter may be attachable to the ring retractor **30**. In one embodiment, the implant introducer has a blade at the end for introduction of the implant, where the blade is retained by the ring retractor **30**.

I claim:

1. A surgical implant inserter comprising

a first enclosure adapted to receive an implant, said first enclosure having a first end with a first opening and a second end with a second opening,

a second enclosure having a first end with a first opening through which a gas or fluid may pass and a second end with a second opening connected to said second end of said first enclosure,

an expansible structure adapted to receive gas or fluid to force an implant received in said first enclosure through said first opening of said first enclosure, said expansible structure being enclosed by said first and second enclosures while said first and second enclosures are in adjacent relationship,

a slit in said first end of said first enclosure adjacent said first opening of said first enclosure, and

a collar disposed around said first end of said first enclosure, adjacent to said first opening of said first enclosure, said collar being movable relative to said first end of said first enclosure to reveal and obscure said slit.

2. A surgical implant inserter comprising

a first enclosure adapted to receive an implant, said first enclosure having a first end with a first opening and a second end with a second opening,

a second enclosure having a first end with a first opening through which a gas or fluid may pass and a second end with a second opening connected to said second end of said first enclosure, and

an expansible structure enclosed by said first and second enclosures while said first and second enclosures are in adjacent relationship, said expansible structure being adapted to receive gas or fluid to force an implant received in said first enclosure through said first opening of said first enclosure.

5

3. The surgical implant inserter of claim 2, further comprising a pressure transmitting member enclosed by said first and second enclosures and interposed between said expandable structure and said first opening of said first enclosure.

4. The surgical implant inserter of claim 2, further comprising a source of gas or fluid. 5

5. The surgical implant inserter of claim 4, wherein the source of gas or fluid is a pump.

6. The surgical implant inserter of claim 4, wherein the source of gas or fluid is a reservoir. 10

7. The surgical implant inserter of claim 2, further comprising a cut-out in said first end of said first enclosure adjacent said first opening of said first enclosure.

8. The surgical implant inserter of claim 2, further comprising a collar disposed around said first end of said first enclosure, adjacent to said first opening of said first enclosure. 15

9. The surgical implant inserter of claim 8, further comprising a slit in said first end of said first enclosure adjacent said first opening of said first enclosure, and wherein said collar is movable relative to said first end of said first enclosure to reveal and obscure said relief cut. 20

10. The surgical implant inserter of claim 2, further comprising a retractor connected to said first end of said first enclosure to retract an incision in a body. 25

11. A surgical implant introducer comprising a first enclosure adapted to receive an implant, said first enclosure having a first end with a first opening and a second end with a second opening,

a second enclosure having a first end with a first opening through which a gas or fluid may pass and a second end with a second opening connected to said second end of said first enclosure, 30

6

an expansible structure adapted to receive gas or fluid to force an implant through said first opening of said first enclosure, said expansible structure being enclosed by said first and second enclosures while said first and second enclosures are in adjacent relationship, and

a pressure transmitting member interposed between said expansible structure and said first opening of said first enclosure.

12. The surgical implant introducer of claim 11, further comprising a source of gas or fluid.

13. The surgical implant introducer of claim 12, wherein the source of gas or fluid is a pump.

14. The surgical implant introducer of claim 12, wherein the source of gas or fluid is a reservoir.

15. The surgical implant introducer of claim 11, further comprising a slit in said first end of said first enclosure adjacent said first opening of said first enclosure.

16. The surgical implant introducer of claim 11, further comprising a collar disposed around said first end of said first enclosure, adjacent to said first opening of said first enclosure.

17. The surgical implant introducer of claim 16, further comprising a cut-out in said first end of said first enclosure adjacent said first opening of said first enclosure, and wherein said collar is movable relative to said first end of said first enclosure to reveal and obscure said cut-out.

18. The surgical implant introducer of claim 11, further comprising a retractor connected to said first end of said first enclosure to retract an incision in a body.

\* \* \* \* \*

UNITED STATES PATENT AND TRADEMARK OFFICE  
**CERTIFICATE OF CORRECTION**

PATENT NO. : 5,571,178

Page 1 of 4

DATED : November 5, 1996

INVENTOR(S) : Walter J. Ledergerber

It is certified that error appears in the above-identified patent and that said Letters Patent is hereby corrected as shown below:

The title page, showing an illustrative figure, should be deleted and substitute therefor the attached title page.

In the drawings, delete FIGS. 1, 2 and 4, and substitute therefor the corrected FIGS. 1, 2 and 4, as shown on the attached pages.

Column 2, line 49, after "reservoir" insert --28--; line 61, after "cut-out" insert --13, 15--.

Column 4, line 21, change "parially" to --partially--.

Column 5, line 22, change "relief cut" to --slit--.

Signed and Sealed this  
Thirteenth Day of May, 1997

Attest:



BRUCE LEHMAN

Attesting Officer

Commissioner of Patents and Trademarks



**United States Patent** [19]  
**Ledergerber**

[11] **Patent Number:** 5,571,178  
 [45] **Date of Patent:** Nov. 5, 1996

[54] **BREAST IMPLANT INTRODUCER**  
 [76] **Inventor:** Walter J. Ledergerber, 31  
 Morningwood, Laguna Niguel, Calif.  
 92677  
 [21] **Appl. No.:** 272,907  
 [22] **Filed:** Jul. 8, 1994  
**Related U.S. Application Data**

3,714,943	2/1973	Yanof et al.	604/70
3,853,125	12/1974	Clark et al.	604/70
4,035,850	7/1977	Cresswall	623/8
4,143,428	3/1979	Cohen	623/8
4,413,986	11/1983	Jacobs	604/14
4,421,508	12/1983	Cohen	604/70
4,610,659	9/1986	Friese	604/15 X
4,624,671	11/1986	Kreas	623/8
4,798,584	1/1989	Hancock et al.	623/8
4,834,094	5/1989	Patton et al.	606/107
4,955,906	9/1990	Coggins et al.	623/8
5,123,905	6/1992	Kelman	

[63] Continuation of Ser. No. 73,966, Jun. 8, 1993, abandoned, which is a continuation of Ser. No. 660,290, Feb. 22, 1991, abandoned.

*Primary Examiner*—David Isabella  
*Attorney, Agent, or Firm*—Lyon & Lyon

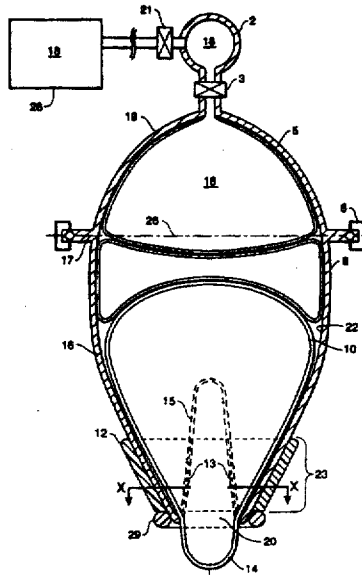
[51] **Int. Cl.<sup>6</sup>** ..... A61F 2/12  
 [52] **U.S. Cl.** ..... 623/8; 623/66  
 [58] **Field of Search** ..... 623/66, 7, 8; 606/107,  
 606/108; 604/15-18, 311, 70, 72, 93

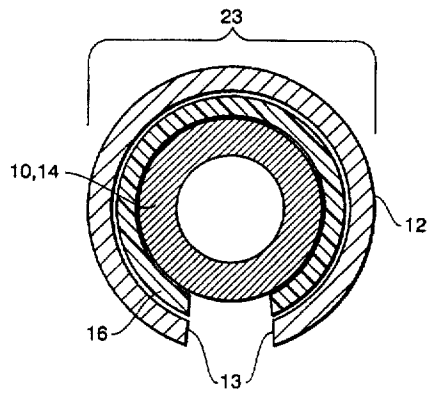
[57] **ABSTRACT**

A tool and method for introducing an implant through an incision in a body utilizing a tube having a hole through which the implant is pressed. In the preferred embodiment, a two part tube has one open end and one closed end. The tube contains an expanding structure, for applying pressure on the implant, optionally a pressure transmitting structure, and an implant. The expanding structure is expanded optionally by gas or fluid filling the structure. Optionally, a collar is disposed around the tube near the opening, selectively covering and uncovering a cut-out in the tube which permits manipulation of the implant prior to insertion.

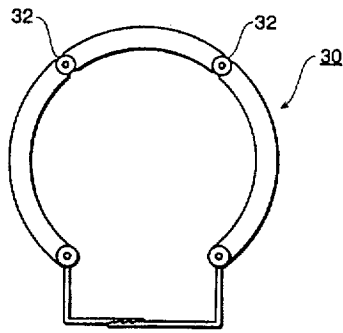
[56] **References Cited**  
**U.S. PATENT DOCUMENTS**  
 747,444 12/1903 Veine ..... 604/59  
 977,004 11/1910 Grimm ..... 604/59  
 2,053,868 9/1936 Grosso ..... 128/20  
 2,509,241 5/1950 Mende ..... 604/11  
 2,587,364 2/1952 Mitchell ..... 604/59  
 2,754,823 7/1956 Müller ..... 604/59  
 3,129,706 4/1964 Reynolds, Jr. .... 128/20

**18 Claims, 3 Drawing Sheets**

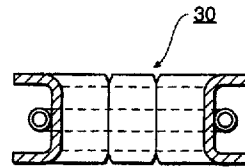




**FIG. 2**



**FIG. 3A**



**FIG. 3B**

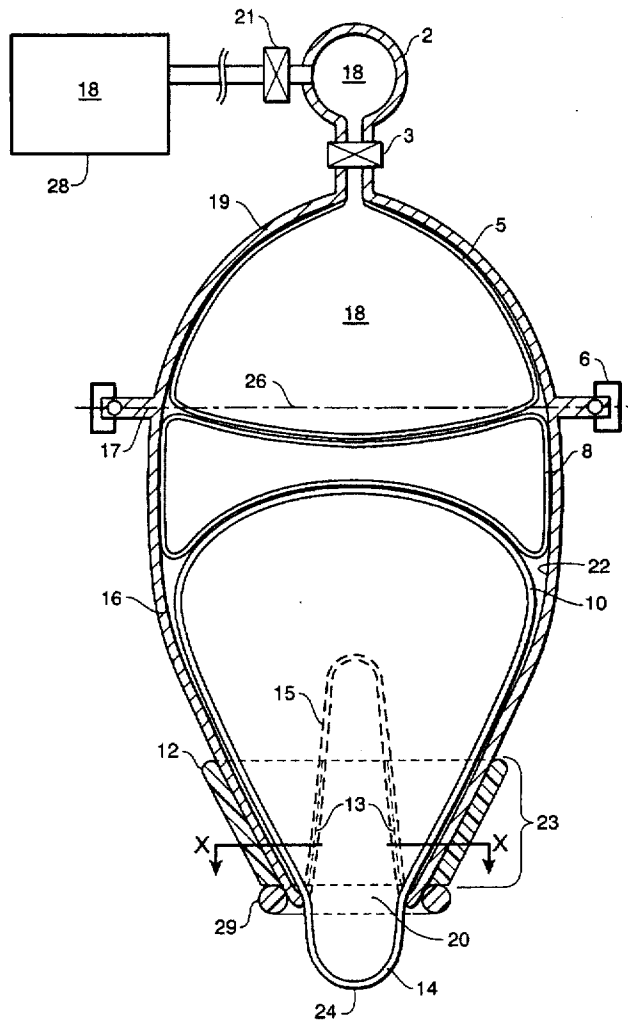


FIG. 1