

Aug. 14, 1962

Z. K. MORAWSKI

3,049,264

SANITARY REMOVABLE COVERS FOR CONTAINERS

Filed June 1, 1959

2 Sheets-Sheet 1

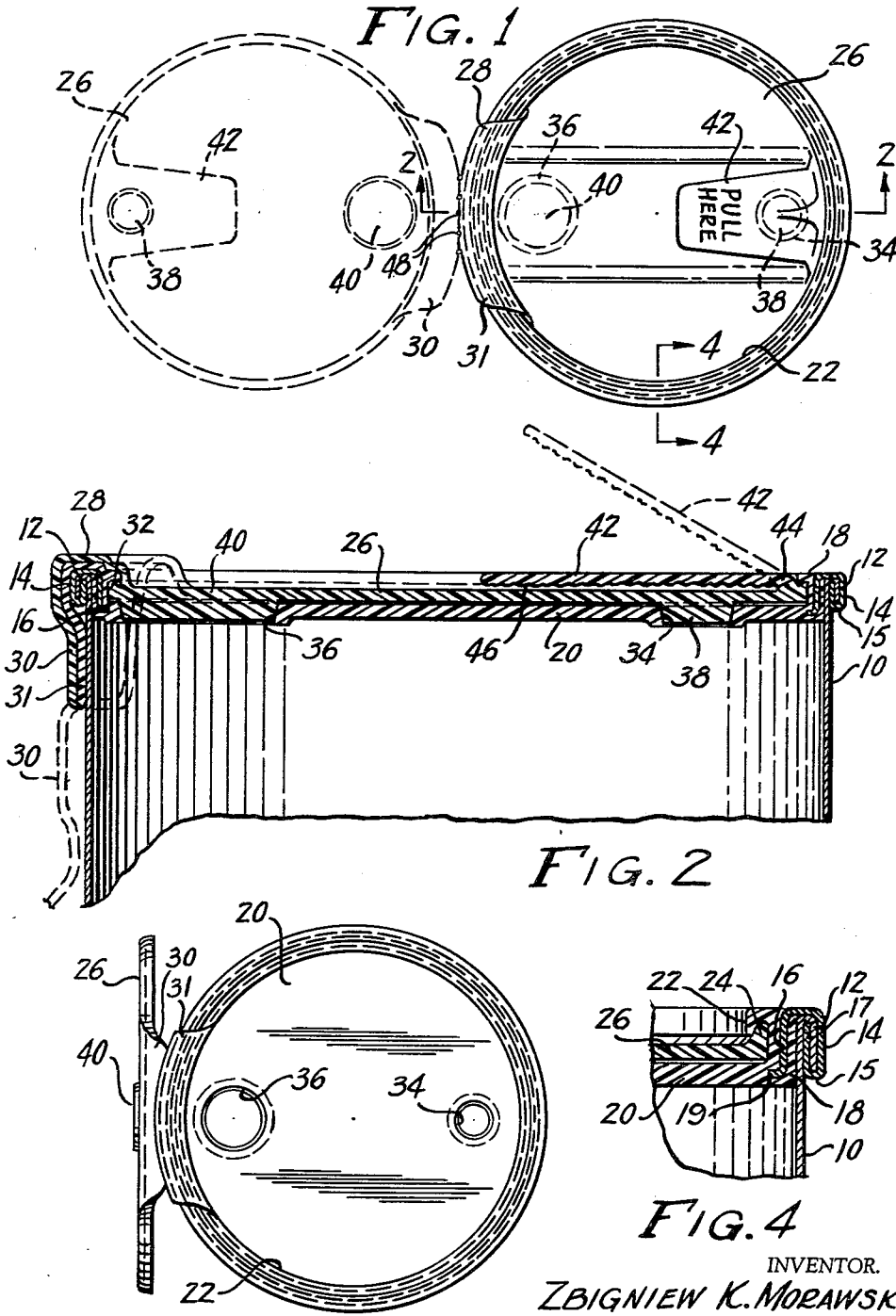

FIG. 2

FIG. 3

FIG. 4

INVENTOR.
ZBIGNIEW K. MORAWSKI
BY
Justin Miller
ATTORNEY

Aug. 14, 1962

Z. K. MORAWSKI

3,049,264

SANITARY REMOVABLE COVERS FOR CONTAINERS

Filed June 1, 1959

2 Sheets-Sheet 2

FIG. 5

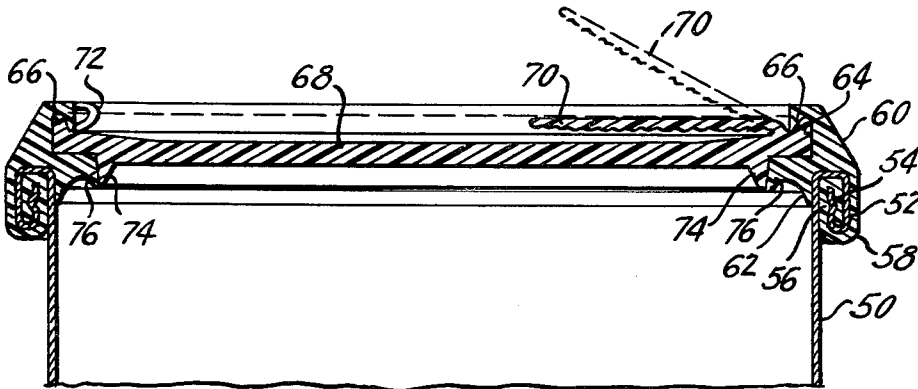
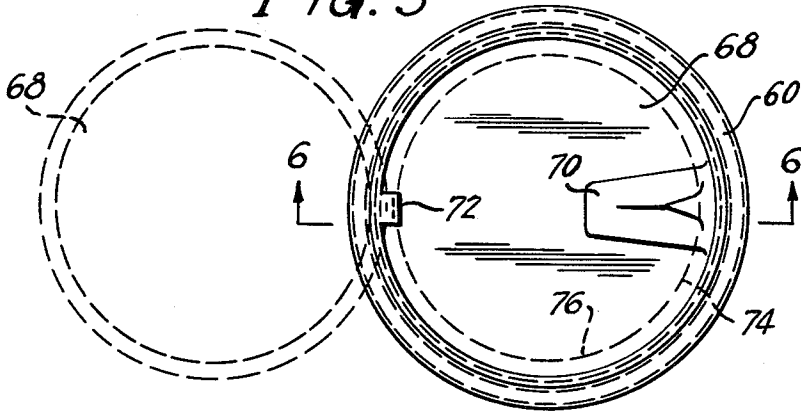

FIG. 6

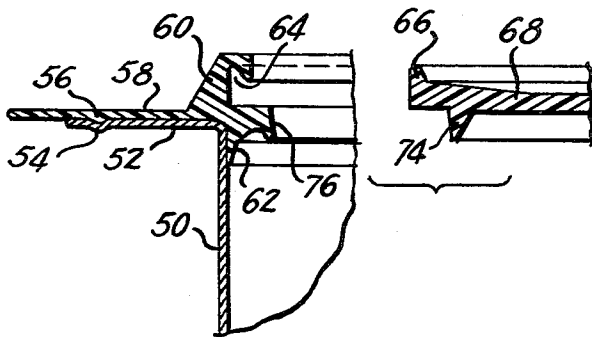

FIG. 7

INVENTOR.
ZBIGNIEW K. MORAWSKI
BY
Gustav Miller
ATTORNEY

1

3,049,264
**SANITARY REMOVABLE COVERS
 FOR CONTAINERS**
 Zbigniew K. Morawski, Fontenet, Charente-
 Maritime, France
 Filed June 1, 1959, Ser. No. 817,115
 2 Claims. (Cl. 220—60)

This invention relates to a covering means for a container such as a can or the like, and it particularly relates to a covering means of the above type which is readily openable and closable.

It has heretofore been the general practice to construct the so-called "tin-can" type of containers with permanently sealed covering means which had to be opened by a can opener or by a punch means in order to gain access to the contents. By this construction, once the can was open, it could not easily be re-sealed so that all the contents had to be removed and the can disposed of as soon as it was opened. Furthermore, it was difficult to drink or eat directly from the opened can because of either the jagged edges caused by the can opener or of the unsanitary opening caused by the not always absolutely clean punch.

It is one object of the present invention to overcome the aforesaid disadvantages by providing a cover means for cans and the like which is easily opened and easily closed in sealing position when desired.

Another object of the present invention is to provide a cover means for cans and the like which affords a sanitary closure and dispensing construction.

Another object of the present invention is to provide a cover means for cans and the like which can be opened without the necessity of using can openers, punch means or other such tools.

Other objects of the present invention are to provide an improved cover means, of the character described, that is easily and economically produced, which is sturdy in construction, and which is highly efficient in operation.

With the above and related objects in view, this invention consists in the details of construction and combination of parts, as will be more fully understood from the following description, when read in conjunction with the accompanying drawings in which:

FIG. 1 is a top plan view of a device embodying the present invention, the cover being shown in closed position.

FIG. 2 is a fragmentary sectional view on line 2—2 of FIG. 1.

FIG. 3 is a top plan view showing the cover in open position.

FIG. 4 is a sectional view taken on line 4—4 of FIG. 1.

FIG. 5 is a top plan view of a modified form of the invention.

FIG. 6 is a fragmentary sectional view taken on line 6—6 of FIG. 5.

FIG. 7 is a fragmentary sectional exploded view of the can and cover assembly of the device of FIGS. 5 and 6.

Referring in greater detail to the drawings wherein similar reference characters refer to similar parts, there is shown a can 10 having a rim 12 over which is positioned a metal sealing ring 14 having an inturned flange 15 and an inner wall 17. The sealing ring 14 has an inner portion 16 extending within the can 10 and an inwardly extending anchor sealing lip 19 while the outer portion of the ring 14 is bent down and around along with the rim 12 whereby the rim 12 is bent downwardly and is enveloped by the ring 14 about the flange 15 and inner wall 17 (as best seen in FIG. 4).

The inner portion 16 of ring 14 and its anchor sealing lip 19 fit within an L-shaped peripheral slot formed in an upstanding peripheral flange 18 of a cover base member 20 constructed of polyethylene or similar plastic material. The member 20 is force-fit into the open top of can 10

2

and is held in position not only by its own frictional engagement but also by the inner portion 16 of ring 14.

The upper edge of the flange 18 of base member 20 is provided with an internally-extending portion 22 having an undercut groove or recess. Within the groove is removably positioned an upstanding rib 24 formed on the periphery of a generally disc-shaped cover 26 preferably constructed of polyethylene or similar material.

The cover 26 is hinged to the can 10 and the cover base 20 by means of an elbow 28 integral with one portion of the periphery of the cover 26. This elbow 28 extends over the ring 14 and down to form an extension 30. This extension 30 is then doubled over to form a two-ply body (as shown in FIG. 2), the inner ply 31 of which bends back to overlie the ring 14. The inner portion of the inner ply 31 of extension 30 is indicated as 32 and is slotted to receive the inner portion 16 of ring 14 in similar manner to the slot in flange 18 (shown in FIG. 4).

The portion 32 is also provided with an undercut groove or recess to mate with that in member 22 for the purpose of receiving the peripheral rib 24 of the cover 26.

The base member 20 is provided adjacent one portion of its periphery with a hole 34 of relatively small diameter and adjacent the opposite portion of its periphery with a relatively larger hole 36. The cover 26 is provided with two depending plugs 38 and 40, the plug 38 being adapted to fit into hole 34 and the plug 40 into hole 36 when the cover 26 is closed (as best seen in FIG. 2). The plugs 38 and 40 are slightly tapered, as shown on the drawing. The cover 26 is also provided with a pull tab 42 integrally connected at one end 44 to the peripheral portion of cover 26. The tab 42 is preferably laterally ribbed, as at 46, to afford a better gripping surface.

The can 10 illustrated is the type utilizable for holding liquids such as beer, soda pop, or the like. With the cover 26 in closed position (as in FIG. 2), the can is completely sealed. When it is desired to open the can, the tab 42 is gripped between the fingers and pulled up to force the rib 24 out from the undercut recess in the portion 22 and to then pivot the cover 26 around the elbow 28 until it hangs down alongside the can 10. In this hanging position, the inner ply 31 of extension 30 supports the cover 26 while the outer ply hangs down. In this position, the hole 34, which is now open, serves as an air vent while the unplugged hole 36 serves as the pouring or dispensing opening. Both of these holes 34 and 36 are always clean since they are always sealed by the plugs 38 and 40 as well as by the cover 26 when not in use. If only a portion of the contents of the can 10 has been used up, the cover 26 may be replaced with the plugs 38 and 40 within their respective holes 34 and 36 to seal the can.

If there is no desire to re-seal the can, the cover 26 may be completely removed. For this purpose, a series of perforations 48 (see FIG. 1) is provided between the plies 30 and 31 so that the ply 30 can easily be torn away from ply 31 which is retained in position.

In some cases, it is preferred to have a completely open upper end on the can instead of just a vent and a pouring opening. This is usually the case when the contents are not beverages, but are vegetables, soups or solids such as coffee, tea, sugar, etc. For this purpose, FIGS. 5 to 7 illustrate a can 50 having an open top defined by a rolled rim 52 formed from a straight upper end. The rim 52 is provided with a sealing crimp or detent 54 to receive a corresponding crimp 56 on a flange 58 extending from a ring 60 constructed of polyethylene or similar material to form a seal therewith. The flange 58 is bent around together with rim 52 to envelop this rim (as shown in FIG. 6).

The ring 60 has a beveled outer surface and is provided with an inner, downwardly depending flange 62 to fric-

tionally engage the inner surface of can 50. The ring 60 is also provided with an inner recess or groove 64 adapted to receive a peripheral upstanding rib 66 of a cover 68 constructed of polyethylene or the like.

The cover 68 is provided with a tab 70 similar to tab 42 and is provided with a hinge of the self-loaded type. This hinge is indicated at 72 and comprises a portion of the ring 60 bent into a semi-circle (as shown in FIG. 6). It is easily detached if the user should desire to remove the entire lid.

The cover 68 is also provided with a depending sealing flange 74 adapted to seal against an internal rim 76 on the ring 60. The flange 74 and rim 76 provide sealing means which are only necessary where the device comprises a highly pressurized or vacuum can. In such case, the flange 74 and rim 76 are heated before the cover is placed on the can. This heating acts to fuse the parts together. In the case of vacuum, the center of the cover 68 is depressed and the flange 74 is thereby forced against the rim 76. When used with a pressurized can, the flange 74 and rim 76 are heated and pre-fused before the cover 68 is assembled with the can 50.

If desired, the top cover 68 can be applied to the can 50 by fusing the flange 74 and rim 76 together, while the can bottom is left open. The can is then filled from the bottom, which is then closed and sealed in the conventional manner.

Although this invention has been described in considerable detail, such description is intended as being illustrative rather than limiting, since the invention may be variously embodied, and the scope of the invention is to be determined as claimed.

Having thus set forth and disclosed the nature of this invention, what is claimed is:

1. In combination, a container of substantially rigid

material having at least one open end, an external bead provided on the rim of said open end, said bead comprising a peripheral cover holder means of flexible plastic material overlying said open end and a peripheral edge of said cover holder means rolled together with said rim, said cover holder means having an inner extending portion within said open end, said inner portion having a peripheral, undercut recess defining a rib extending inwardly thereover, a substantially flat cover, a hinge integrally linking said cover to said cover holder means at one side thereof, a thickened peripheral rib on said cover complementary to said cover means holder undercut recess and resiliently and detachably held in closed sealing position therein by said cover holder means peripheral rib, a pull tab integrally secured to said cover on the side opposite from said hinge side for withdrawing said cover from said closed sealing position, said cover holder means having at least one pour aperture therethrough, and a plug means depending from the underside of said cover complementary to said pour aperture and sealingly engaged therein when said cover is held in said closed sealing position.

2. The combination of claim 1, said cover holder means having another aperture therethrough displaced from said pour aperture and providing a vent aperture, and a second depending plug means on the underside of said cover complementary to said vent aperture and also sealingly engaged therein when said cover is held in said closed sealed position.

References Cited in the file of this patent

UNITED STATES PATENTS

2,106,330	Sebell	Jan. 25, 1938
2,130,676	Sebell	Sept. 20, 1938
2,894,654	Lohrer	July 14, 1959