



US 20120144544A1

(19) **United States**

(12) **Patent Application Publication**  
**TELFER et al.**

(10) **Pub. No.: US 2012/0144544 A1**

(43) **Pub. Date: Jun. 14, 2012**

(54) **GARMENT USED FOR SKATEBOARD RIDING**

*A41D 19/015* (2006.01)

*A41D 27/10* (2006.01)

(52) **U.S. Cl.** ..... 2/20; 2/269; 2/270; 2/161.1

(75) **Inventors:** **Dennis John TELFER**, Encinitas, CA (US); **Steve Alan Lake**, Encinitas, CA (US)

(57) **ABSTRACT**

(73) **Assignee:** **SEAL TRADEMARKS PTY LTD.**, Queensland (AU)

A garment having a sleeve, the sleeve including a cuff movable between a retracted position in which an end of the retracted cuff rests proximate the wrist of the user, and an extended position in which the end of the cuff extends over at least part of the hand of the user, the cuff including an attachment region for attaching a protective device thereto. The attachment region of the cuff is exposed when the cuff is in the extended position and allows a protective device, such as a puck, to be releasably attached to the cuff. The protective device facilitates sliding during skateboarding by placing the protective device into contact with the ground, the protective device slides over the ground while providing protection to the hand of the user. The cuff may be secured in place with a loop in the cuff that can be tightened.

(21) **Appl. No.:** **12/966,500**

(22) **Filed:** **Dec. 13, 2010**

**Publication Classification**

(51) **Int. Cl.**  
*A41D 13/00* (2006.01)  
*A63B 71/14* (2006.01)

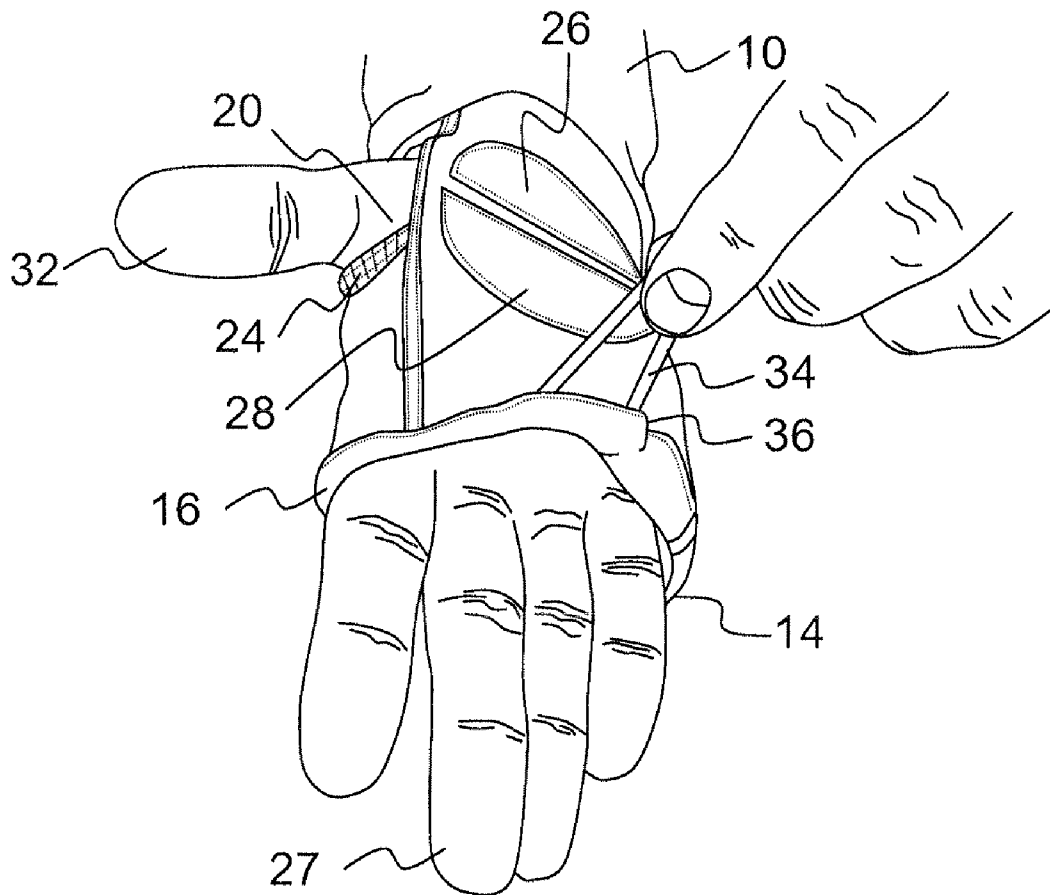

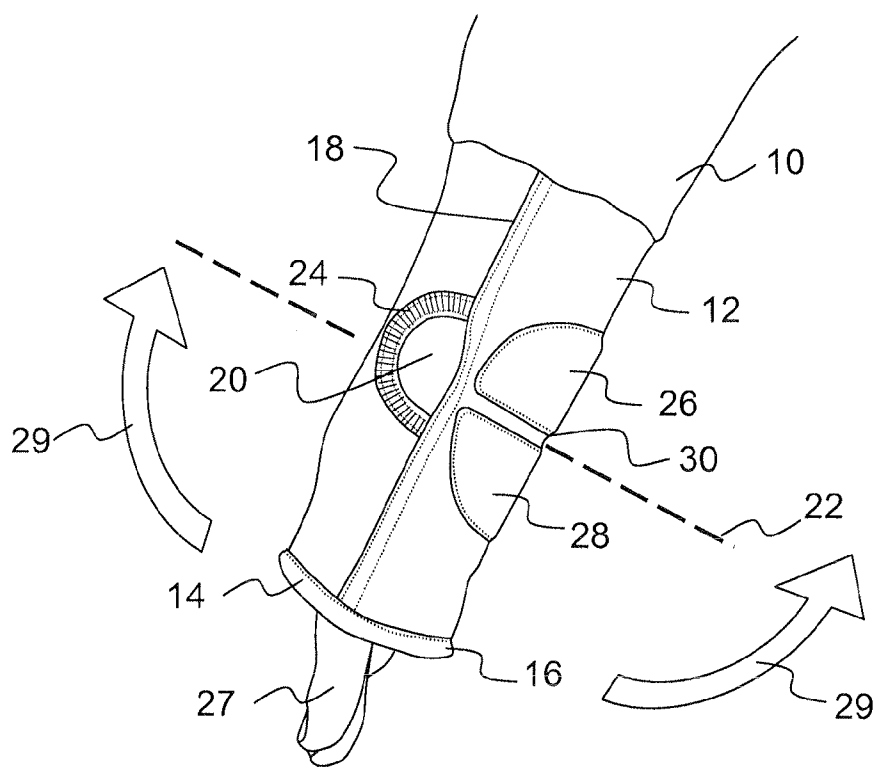
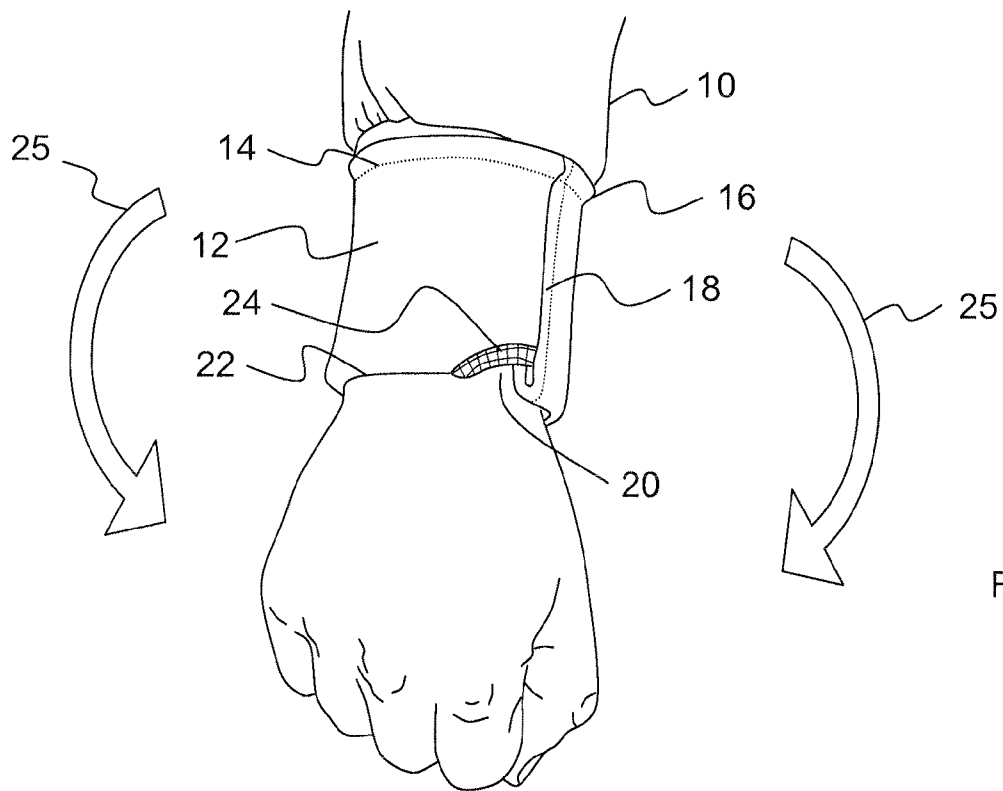

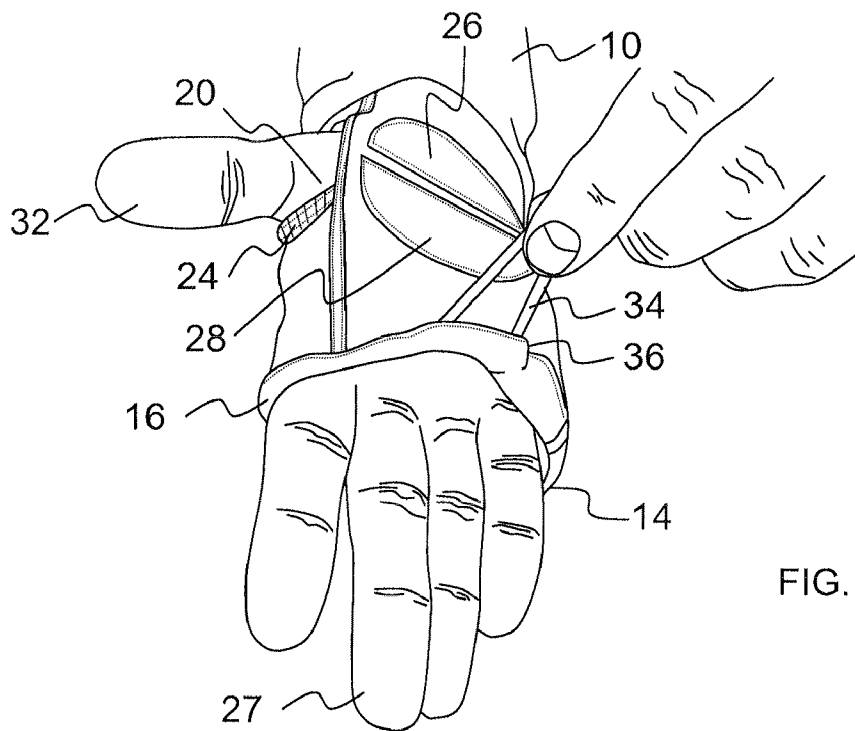

FIG. 3

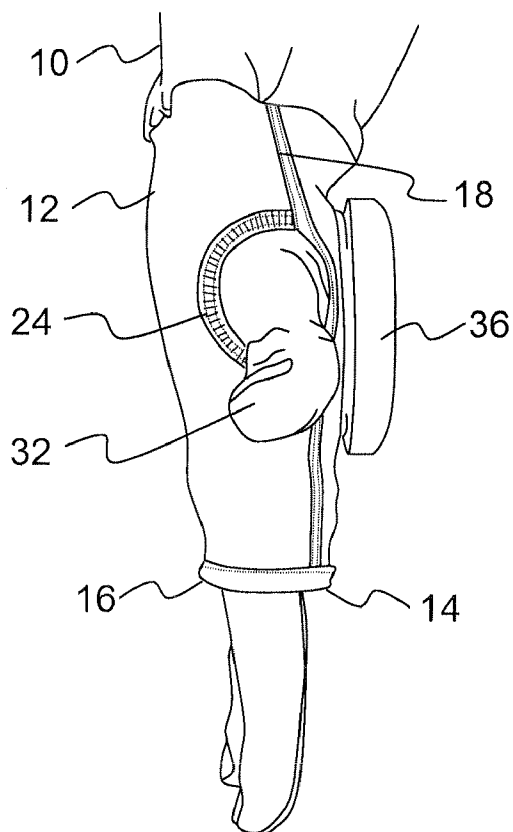

FIG. 4

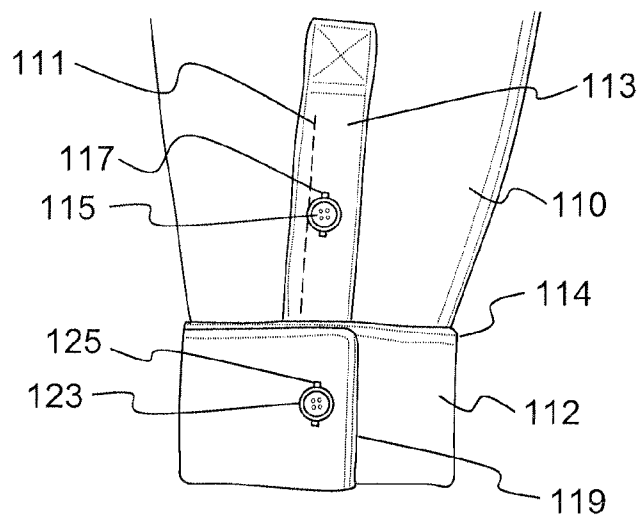

FIG. 5

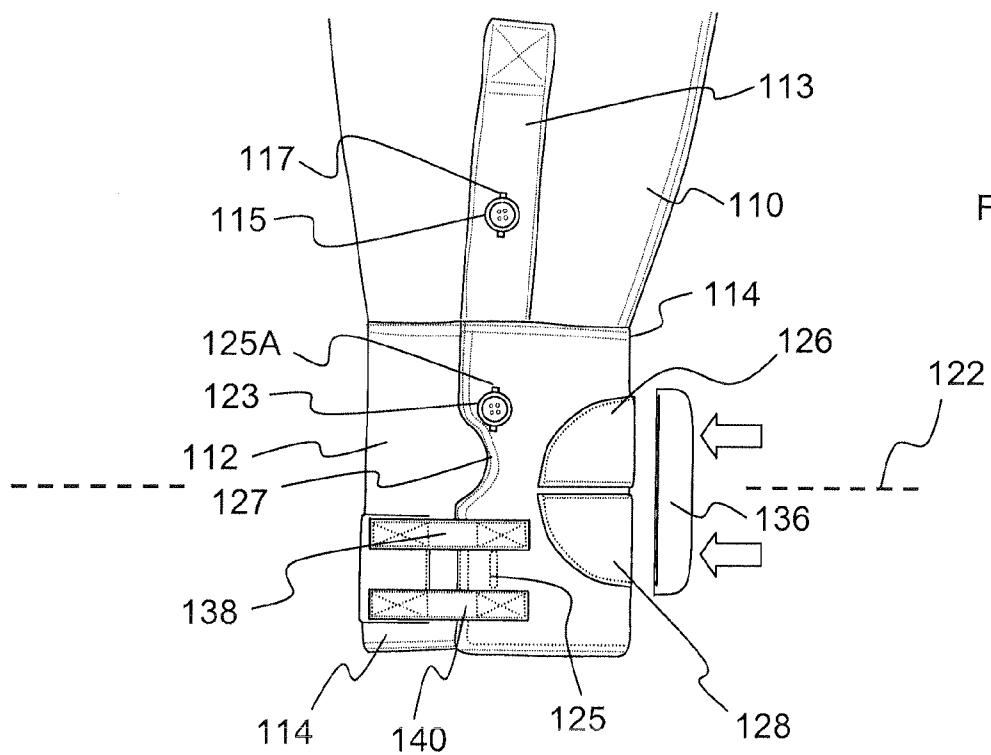
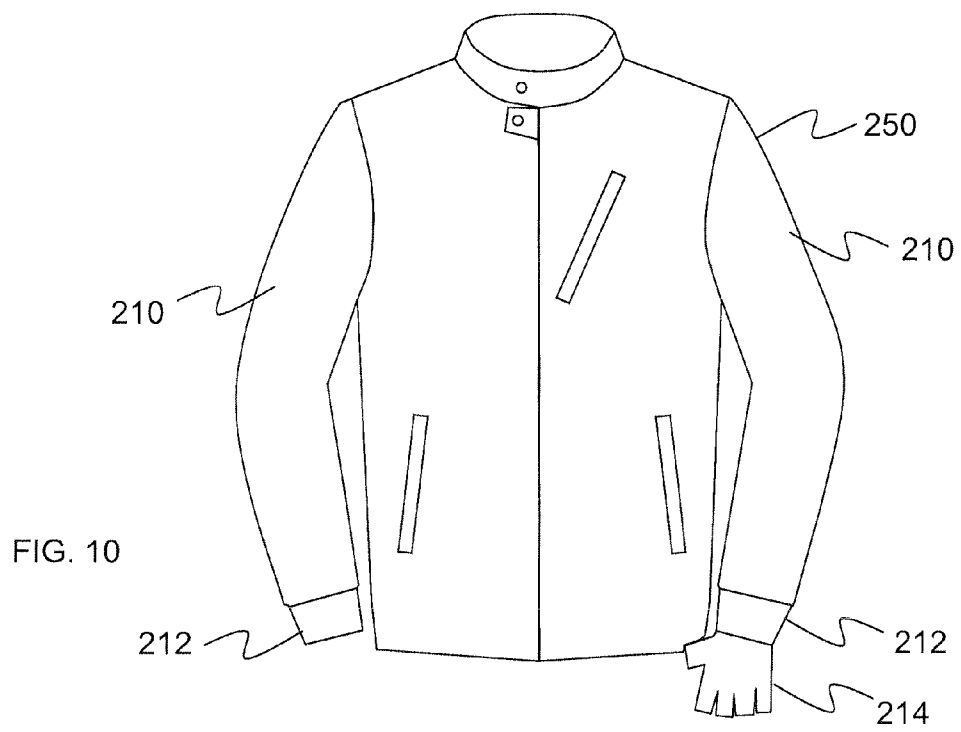
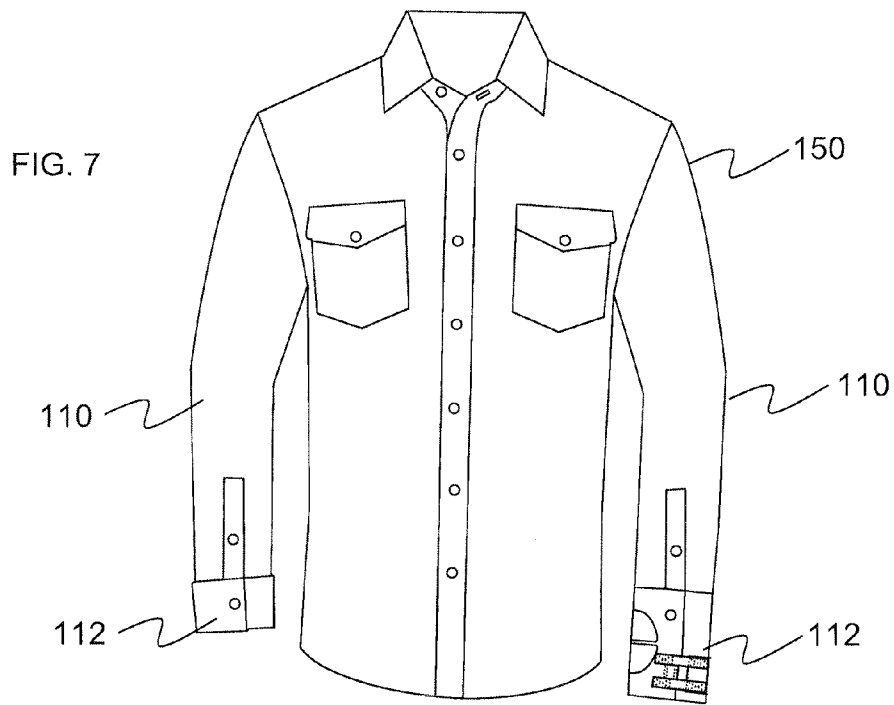

FIG. 6



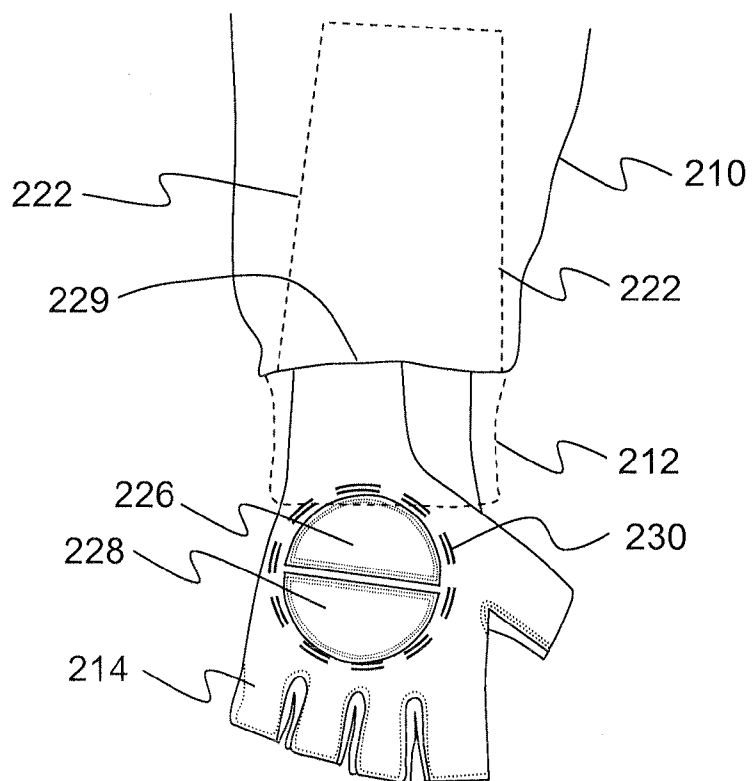
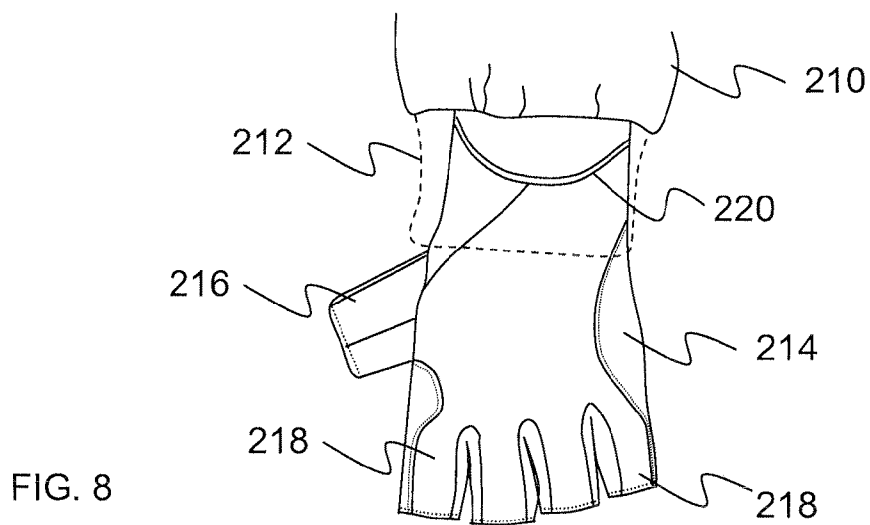

FIG. 9

**GARMENT USED FOR SKATEBOARD RIDING**

**FIELD OF THE INVENTION**

[0001] The present invention relates to a garment. More particularly, the present invention relates to a garment in which protective devices for the palm of a user can be releaseably attached to the garment.

**BACKGROUND TO THE INVENTION**

[0002] Skateboard riding is a widely practised pastime and sport that is enjoyed by a large number of people. In skateboarding, a number of skateboard riders have taken to skateboarding down hills. Traditional skateboard riding typically involves the rider transferring his/her weight from side to side to cause the skateboard to turn. However, it has been found that riders can also put their hand on the ground on the inside of a turn in order to facilitate longer and more controlled turn. These long controlled turns are referred to as “slides” and often involve a prolonged period during which the rider slides his or her hand along the surface of the ground.

[0003] In order to protect the hands of skateboarders, sliding gloves have been developed. Typical sliding gloves have a region on the palm or on the inside of the wrist to which a sliding puck is attached. The puck is typically made of a semi-hardened plastic that allows the rider to slide his hand along the ground for stabilization. The puck lets the rider put his/her hands directly down on the road surface, thereby facilitating longer and more controlled slides and protects the rider’s hands from abrasion on the ground or road surface in the event of a fall. When the rider has finished skateboarding, the gloves may be removed.

[0004] A problem that arises with present sliding gloves is that, when not in use, they must be stored. This leaves open the possibility that the gloves may become lost or stolen. The pucks are formed from a relatively hard, abrasion resistant material and they have a shape and size that is similar to an ice hockey puck. The pucks are quite stiff and inhibit movement of the hand of the user when the user is not involved in skateboarding activities. Consequently, in some sliding gloves, the pucks are releaseably secured to the glove, such as by use of a hook and loop fastener, such as VELCRO™ or by use of other fasteners, such as clips, zips, buttons, press studs or by inserting the pucks into an envelope or window formed in the glove. The pucks too must be separately stored and this can also lead to the possibility that the pucks can be lost or stolen.

[0005] Clothing articles, such as coats and sweaters, that are worn in cold weather, include long sleeves that extend to the wrist of the wearer. There have been some efforts in the past to provide such clothing articles with extendable cuff regions in order to keep the hands of the wearer warm. For example, U.S. Pat. No. 5,504,944 in the name of Bromer et al describes a coat sleeve that includes a cuff that folds down to cover the palm portion of the hand. The cuff is held in place over the palm by constrictions about the wrist and knuckles. The constrictions include a means for snugging and loosening of the cuff in the region of the wrist of the wearer and in the region of the knuckles of the wearer. During use, the fingers of the wearer extend through the end of the cuff and the thumb of the wearer extends through a hole that is formed in the cuff. No provision is made for attaching any devices to this gar-

ment for facilitating sliding during skateboarding or for providing enhanced protection during sliding whilst skateboarding.

[0006] U.S. Pat. No. 5,784,720 in the name of Mellon et al describes a garment having a cuff construction with an opening for permitting the thumb of the wearer and the fingers to extend outside the sleeve. The cuff is generally integrally attached to an article of clothing and folds on itself for storage, permitting the use or non-use of the cuff at the user’s discretion. The cuff is formed at an opening of the sleeve and includes a tubular member which is switchable between a first rolled position allowing the hand to pass through and a second rolled position forming a covering around at least a portion of the hand and/or thumb while leaving the ends of the fingers exposed. The cuff includes a tubular portion extending from the thumb opening and covering at least a portion of the thumb of the wearer. This garment is provided to keep the wearer warm during cold weather. Nothing in this patent describes the garment as being suitable for use during sliding whilst skateboarding.

[0007] U.S. Pat. No. 5,794,265 in the name of Reich describes a garment sleeve of relatively long length with an open distal end and an opposite proximate end secured to the garment contains a hollow flexible article of relatively short length and having first and second opposite ends. The hollow flexible article has a relatively small thumb hole intermediate its first and second ends. One end of the article is disposed within the distal end of the sleeve and is peripherally sealed to the interior of the sleeve. When a user dons the garment, the hand and arm engage with the hollow flexible article and move the hollow flexible article to an extended position. When the user removes the garment, withdrawal of the hand from the sleeve pulls the hollow flexible article inside the sleeve such that it cannot be seen. No provision is made for attaching any devices to this garment for facilitating sliding during skateboarding or for providing enhanced protection during sliding whilst skateboarding. Nothing in this patent describes the garment as being suitable for use during sliding whilst skateboarding.

[0008] U.S. Pat. No. 4,999,849 in the name of Grilliot et al describes a firefighter’s coat that has a long wristlet region that extends to cover the wrist and the back of the hand of a firefighter. The wristlet region has a strip of flexible material connected to the edge part, with the strip of flexible material being adapted to be positioned between two digits of the hand of the firefighter, such as between the thumb and the adjacent finger of the hand of the firefighter. Thus, the sleeve portion is maintained in covering relationship upon the wrist of the firefighter, even while the arms and hands of the firefighter are actively moved in a firefighting operation. This patent is directed towards protective clothing to shield a firefighter from a fire, and would not be suitable for use by an active skateboarder.

**SUMMARY OF THE INVENTION**

[0009] It is an object of the present invention to provide a garment or an article of clothing that is specifically designed for skateboarding activities or that provides “skate functional” clothing.

[0010] It is another object of the present invention to provide a garment or an article of clothing that has a convertible cuff region that can be moved between the folded position and an extended, in use position, with the cuff allowing a protective device, such as a puck, to be secured to the palm region or

the inner wrist region or the region of the heel of the hand when the cuff is in the in-use position.

**[0011]** In a first aspect, the present invention provides a garment having a sleeve, the sleeve including a cuff movable between a retracted position in which an end of the retracted cuff rests proximate the wrist of the user, and an extended position in which the end of the cuff extends over at least part of the hand of the user, the cuff including an attachment region for attaching a protective device thereto. The protective device facilitates sliding during skateboarding by placing the protective device into contact with the ground, the protective device slides over the ground whilst also providing protection to the hand of the user. The attachment region is exposed when the cuff is in the extended position, and positioned adjacent to the palm, inner wrist or heel of the hand of the user when the cuff is in the extended position.

**[0012]** In some embodiments, the cuff may include a thumb hole through which the thumb of a wearer can pass when the cuff is in the extended position. This assists in maintaining the cuff in the extended position.

**[0013]** In some embodiments, the cuff may include a loop for extending around one or more fingers of the user. The loop may suitably extend around one or two fingers of the user. The loop may be located in a distal region of the extended cuff. The loop may comprise a loop of elasticised material. The loop may extend around a periphery of the distal end of the cuff so that positioning the loop over a finger of the user also acts to tighten the loop around the periphery of the end of the cuff.

**[0014]** In some embodiments, the cuff may have an adjustable size near the distal end of the cuff when the cuff is in the extended position. For example, the cuff may be provided with one or more buttons, press studs, clips, hook and loop type fasteners, or indeed any other type of releasable fastener, or ties or buckles or elasticised portions or elasticised loops that enables the cuff to be tightened over the hand of the user when the cuff is in the extended position. This minimises the likelihood of the cuff riding up over the hand and wrist of the user during use. It will be appreciated that it is an undesirable result to have the cuff ride up over the hand and wrist of the user during use as this will result in the protective device not being correctly positioned, thereby exposing the hand of the user to possible injury.

**[0015]** In some embodiments, the distal end of the cuff comprises a tubular portion having an opening at an end thereof. In other embodiments, the distal end of the cuff comprises a slit extending away from the opening towards the wrist of the user, and one or more closures for securing opposed sides of the slit to each other. The closures may comprise one or more buttons, zips, press studs, clips, hook and loop type fasteners, cuff links and the like. The opposed sides of the slits may overlie each other.

**[0016]** The attachment region of the cuff is exposed when the cuff is in the extended position. The attachment region allows a protective device, such as a puck, to be releasably attached to the cuff. The attachment region may comprise a hook and loop type fastener on the cuff. Other attachments, such as one or more buttons, buttonholes, zips, press studs, clips, magnetic fasteners, an envelope or a pocket of fabric into which the protective device may be inserted, or the like may be used. Indeed, the present invention encompasses the use of any attachment means that allow a protective device to be releasably attached to the cuff.

**[0017]** The attachment region may comprise an attachment means, as described above, that is affixed to the cuff. The attachment region is located at a position adjacent to the palm, the inner wrist, or the heel of the hand of the user when the cuff is in the extended position. This, of course, results in the protective device being attached to the cuff so that the protective device is positioned adjacent to the palm, the inner wrist or the heel of the hand of the user when the protective device is attached to the attachment region. This properly positions the protective device for use in facilitating longer more controlled slides during skateboarding.

**[0018]** The protective device suitably comprises a protective device useful for facilitating longer more controlled slides during skateboarding. The protective device may comprise a puck, such as a generally cylindrical protective device having dimensions similar to an ice hockey puck. Other shaped protective devices, such as square, rectangular, triangular, pentagonal, hexagonal, etc may also be used. The protective device may be in the form of a generally prism shaped article having a cross-sectional shape as described immediately above. The protective device may be made from a relatively hard rubber material or from a relatively hard plastic material. It will be understood that the protective device may also be made from wood or metal. The protective device suitably is made from a material that allows the protective device to slide across a surface, such as across a road surface or a concrete surface, with minimal friction and without grabbing onto the surface. It will be appreciated that if the protective device has a tendency to grab onto the surface across which it is sliding, the likelihood of the wearer falling off a skateboard when the protective device grabs onto the surface is increased. This is not desirable as it is likely to result in injury to the rider.

**[0019]** The protective device suitably includes a complementary attachment for attaching to the attachment region. The person skilled in the art will readily appreciate the types of complementary attachment devices that may be used with the puck.

**[0020]** In some embodiments, the attachment region may comprise a releasable adhesive attached or fixed to the cuff. Alternatively, a releasable adhesive may be attached or fixed to the protective device.

**[0021]** In one embodiment the attachment region suitably comprises a region of hook and loop fastener material attached to the cuff. The region of hook and loop fastener material may largely correspond to a shape of a similar region of complementary hook and loop fastener material attached to the protective device. For example, if the protective device comprises a cylinder of material having a hook part or a loop part of a hook and loop fastener material attached to one of its circular faces, a largely circular region of the complementary loop part or hook part of the hook and loop fastener material may be attached to the attachment region of the cuff.

**[0022]** In another aspect, the present invention provides a garment having a sleeve, the sleeve including a glove portion attached at or near a distal end thereof, the glove portion being movable between a retracted position in which the glove portion lies within the sleeve, to an extended position in which the glove portion extends from the sleeve and covers at least part of the hand of a user. The glove portion includes an attachment region for attaching a protective device thereto. The protective device facilitates sliding during skateboarding by placing the protective device into contact with the ground, the protective device slides over the ground to provide pro-



tection to the hand of the user. The attachment region is exposed when the glove portion is in the extended position, the attachment region being positioned adjacent to the palm, inner wrist or heel of the hand of the user when the glove portion is in the extended position.

[0023] The glove portion may include at least a thumb receiving region and one or more finger receiving regions. The glove portion may completely enclose the thumb and fingers of the user. Alternatively, the glove portion may have a cut-off thumb and fingers so that the thumb and fingers of the user extend through openings in the glove portion.

[0024] The glove portion may be attached to an inner part of the sleeve. In order to enable the hand of the user to extend past the glove portion and out of the sleeve when the glove portion is in the retracted position, only a part of the distal end of the glove portion may be attached to the inner part of the sleeve. This will leave an opening through the sleeve past the glove portion when the glove portion is in the retracted position. The glove portion may be sewn into the sleeve, heat sealed to the sleeve, or it may be joined to the sleeve by use of a suitable adhesive or double sided adhesive tape, or attached using other techniques known in the art.

[0025] In all embodiments of the present invention, the garment may be provided with one or more pockets to store the protective device when the protective device has been removed from the cuff or glove portion of the garment. The present invention also relates to a combination of the garment as described above with a protective device removably attached to the attachment region.

#### BRIEF DESCRIPTION OF THE FIGURES

[0026] The nature, objects, and advantages of the present invention will become more apparent to those skilled in the art after considering the following detailed description in connection with the accompanying drawings, in which like reference numerals designate like parts throughout, and wherein:

[0027] FIG. 1 shows a view of an end of a sleeve of a garment in accordance with one embodiment of the present invention having the cuff in the retracted position;

[0028] FIG. 2 shows the garment shown in FIG. 1 with the cuff in an extended position exposing the thumb hole and the attachment region;

[0029] FIG. 3 shows the garment shown in FIG. 2 with the thumb of the wearer extending through the thumb hole and showing a loop ready to be positioned over a finger of the wearer;

[0030] FIG. 4 is a side view of the garment shown in FIG. 3 with a protective device, in the form of a puck, attached to the attachment region;

[0031] FIG. 5 shows a view of an end of a sleeve of a garment in accordance with another embodiment of the present invention having the cuff in the retracted position;

[0032] FIG. 6 shows a view of the garment of FIG. 5 with the cuff in the extended position showing the attachment region and a puck positioned for attachment;

[0033] FIG. 7 is a front view of a garment incorporating the sleeve as shown in FIGS. 5 and 6;

[0034] FIG. 8 shows a view of an end of a sleeve of a garment in accordance with a further embodiment of the present invention, with the garment of the embodiment shown in FIG. 8 having a glove portion;

[0035] FIG. 9 is a view from the other side of the sleeve shown in FIG. 8; and

[0036] FIG. 10 shows a view of a garment incorporating the sleeve as shown in FIGS. 8 and 9.

#### DETAILED DESCRIPTION OF THE DRAWINGS

[0037] It will be appreciated that the drawings have been provided for the purposes of illustrating embodiments of the present invention. Therefore, it will be understood that present invention should not be considered to be limited solely to the features as shown in the drawings.

[0038] FIG. 1 shows a view of an end of a sleeve of a garment in accordance with one embodiment of the present invention. In FIG. 1, the garment (not shown in full) has a sleeve 10 having a cuff 12. In FIG. 1, the cuff 12 is shown in the retracted position. In particular, in FIG. 1, the cuff 12 is folded back upon itself so that the end 14 of the cuff 12 is located above the wrist of the wearer. The end 14 includes a pocket 16 sewn therein. A band of elasticized material (not shown in FIG. 1) runs through pocket 16 to form a loop of elasticised material in the pocket 16. The loop of elasticised material applies a light grip pressure to the end 14, which results in the end 14 lightly gripping the underlying arm of the wearer, thereby assisting in retaining the end 14 in the retracted position as shown in FIG. 1.

[0039] The cuff 12 is formed by sewing a piece of fabric or material into a generally tubular shape. Seam 18 arises from this sewing procedure.

[0040] The cuff 12 is also provided with a thumb opening 20. In the retracted position as shown in FIG. 1, the thumb opening 20 is generally positioned at or along a fold line 22 that defines the end of the cuff that is closest to the fingers of the wearer when the cuff 12 is in the retracted position as shown in FIG. 1. The thumb opening 20 may be provided with a stretchy or elasticised band 24 to increase comfort for the wearer.

[0041] The cuff 12 may be moved in direction 25 from the retracted position as shown in FIG. 1 to the extended position shown in FIG. 2 by simply rolling the end 14 of the cuff 12 downwardly over the wrist and hand of the wearer. As can be seen from FIG. 2, when the cuff 12 is in the extended position, the end 14 of the cuff 12 is positioned so that it is located around the fingers 27 of the wearer. In this extended position, the heel of the hand, the inner wrist and most, if not all, of the palm of the hand of the wearer is covered by the extended cuff. FIG. 2 also clearly shows the thumb hole 20 (although in FIG. 2 the thumb of the wearer has not yet been extended through the thumb hole 20). As can also be seen from FIG. 2, the cuff 12 includes attachment regions 26, 28. Attachment region 26 may comprise a generally semicircular piece of hook or loop fastener material (which is complementary to the other of a piece of hook or loop fastener material that is attached to the protective device). Similarly, attachment region 28 may also comprise a generally semicircular piece of hook or loop fastener material. As can be seen from FIG. 2, attachment region 26 is separated from attachment region 28 by a space 30. Space 30 extends generally along the fold line 22 (shown in dashed lines) that exists when the cuff 12 is folded back upon itself to place the cuff 12 in the retracted position shown in FIG. 1. Space 30 allows the cuff 12 to fold cleanly along fold line 22 adopt a more neat configuration when the cuff 12 is in the retracted position shown in FIG. 1.

[0042] In order to fully fit the cuff 12 in the extended position, the thumb 32 of the user is extended through the thumb hole 20 (see FIG. 3). The elasticised loop of material 34 that extends through the pocket 16 located in the distal end

**14** of the cuff **12** is stretched out through one or two openings (one of which is shown at **36** in FIG. **3**) in the pocket **16** and the exposed part of the elasticised loop of material **34** is then slipped over one of the fingers **27** of the wearer. Typically, the portion **34** of the elasticised loop of material will be slipped over the middle finger of the wearer. This assists in holding the end **14** of the cuff in the position shown in FIG. **4**. This is achieved because the portion **34** of the elasticised loop of material fits over a finger of the wearer and acts to hold the end **14** in place by interaction with the finger of the wearer. Further, stretching the elasticised loop material out through the openings **36** in the pocket **16** also pulls the elasticised loop of material tighter in the pocket **16**, which thereby causes the pocket **16** to grip the fingers of the user.

**[0043]** As shown in FIG. **4**, a puck **36** can be secured to the attachment regions **26**, **28** of the cuff **12**. The puck **36** may comprise a puck that is commercially available for use with sliding gloves for skateboarding. The puck **36** may be made, for example, from a plastics material that exhibits high stiffness, low friction and a low wear rate. The puck may be made from a polyoxymethylene plastic material, such as the material commercially available under the trademark DELRIN. Alternatively, the puck may be made from high-density polyethylene, polypropylene, or a polyamide plastic (such as nylon). Other materials, such as other plastics, wood or metal may also be used. The puck **36** may have the hook or loop material that is complementary to the hook or loop material that forms the attachment regions **26**, **28** on the cuff **12** attached to one surface of the puck **36**. This enables easy securement of the puck **36** to the attachment regions **26**, **28** of the cuff **12**. For example, the attachment regions **26**, **28** may comprise the hook component of a VELCRO fastener, with the loop component of the VELCRO fastener being attached to the puck. Alternatively, the attachment regions **26**, **28** may comprise the loop component of a VELCRO fastener, with the hook component of the VELCRO fastener being attached to the puck. Alternatively, one of the regions **26**, **28** may comprise the hook component of a VELCRO material and the other of the regions **26**, **28** may comprise the loop component of a VELCRO fastener, with the puck having one region of hook component and another region of loop component to enable the puck to be affixed to the regions **26**, **28**. A further advantage of this embodiment is that the regions **26**, **28** come into face-to-face abutment when the cuff **12** is in the retracted position shown in FIG. **1** and the regions **26**, **28** become fastened to each other to thereby assist in holding the cuff **12** in the retracted position shown in FIG. **1**.

**[0044]** Once the puck **36** has been secured to the cuff **12**, the wearer is ready to go skateboarding. After skateboarding has been completed, the puck **36** may be easily removed from the attachment regions **26** and **28**, the loop **34** of elasticised material taken off the finger **27** of the wearer and the thumb **32** of the wearer removed from the thumb hole **20**. The cuff **12** may then be folded in direction **29** from the extended position shown in FIG. **2**, back to the retracted position shown in FIG. **1**. The puck may be placed in a pocket of the garment for easy storage.

**[0045]** FIGS. **5** and **6** show views of an end of a sleeve of a garment in accordance with an alternative embodiment of the present invention. In FIGS. **5** and **6**, the garment comprises a sleeve **110** having a cuff **112**. The sleeve **110** is similar to a shirt sleeve on a long-sleeved business shirt. It includes a longitudinal slit **111** (shown in dashed line) that is located under material **113**. Material **113** overlies another piece of

material on the sleeve that defines an edge of the slit (it being appreciated that the slit extends upwardly along the sleeve). A button **115** that is sewn onto the underlying material extends through a buttonhole **117** in the material **113** to thereby close the slit **111**.

**[0046]** The cuff **112** includes an end **114** that, in the retracted position shown in FIG. **5**, sits adjacent to a region where the cuff **112** is joined to the sleeve **110**. Unlike the embodiment shown in FIG. **1**, in which the cuff comprises a tubular piece of material having a longitudinally extending seam, in the embodiment shown in FIG. **5** the cuff **112** has two overlying edges. One of the edges **119** is shown in FIG. **5** and the other of the edges **121** is shown in FIG. **6**. A button **123** is fixed to an underlying part of the cuff **112**. The button **123** can pass through a buttonholes **125A** and **125** to hold the cuff **112** in the retracted position shown in FIG. **5**. The buttonhole **125** and **125A** are also shown in FIG. **6**.

**[0047]** In order to move the cuff **112** from the retracted position shown in FIG. **5** to the extended position shown in FIG. **6**, the button **123** is undone and the end **114** of the cuff **112** is moved downwardly to the position as shown in FIG. **6**. As can be seen, in the extended position shown in FIG. **6**, the attachment regions **126**, **128** are exposed and a puck **136** can be attached thereto. Attachment regions **126**, **128** are separated by a fold line **122** facilitating the easy folding of cuff **112** into the retracted position.

**[0048]** Unlike the embodiment shown in FIGS. **1** to **4**, the embodiment shown in FIGS. **5** and **6** does not include a specific thumb hole. However, it can be seen that edge **121** includes a recessed region **127** and the wearer may extend his/her thumb between the edges of the material **119**, **121** in the vicinity of recessed region **127**. In this manner, the recessed region **127** will act to engage with the thumb of the wearer to assist in holding the cuff **112** in the extended position. Releasable straps **138**, **140** may also be provided on the cuffs. The straps **138**, **140** may be sewn at one end to one side of the cuff and may be fitted with a releasable fastener at the other end to enable the other end to be attached to the opposed strip of material that makes up the cuff **112**. This can act to pull the cuff **112** more tightly about the fingers of the wearer to thereby assist in maintaining the cuff **112** in the extended position as shown in FIG. **6**.

**[0049]** FIG. **7** shows a garment in the form of a shirt **150** having sleeves **110**. The sleeves of the garment are as shown in FIGS. **5** and **6**. In FIG. **7**, the cuff **112** shown on the left-hand side of the figure is in the retracted position whilst the cuff **112** shown on the right-hand side of the figure is in the extended position.

**[0050]** FIGS. **8** and **9** show a view of an end of a sleeve in accordance with another embodiment of the present invention, in which the end of the sleeve is provided with a glove portion **214**. In FIGS. **8** and **9**, the sleeve **210** has a cuff **212**. Cuff **212** may be a conventional cuff for use on a sweatshirt, a hooded jacket, a windbreak jacket or the like. The sleeve **210** has a glove portion **214** attached to an inner part of the sleeve **210**. The glove portion **214** includes a thumb portion **216** and finger portions **218**. The thumb portion **216** and finger portions **218** are designed to extend only partly over the thumb and fingers of the wearer. The thumb and finger portions have openings that allow the thumb and fingers of the wearer to extend therethrough. As shown in FIG. **8**, the glove portion **214** includes a free edge **220** that is positioned beneath the cuff **212** (the cuff **212** shown in FIGS. **8** and **9** is shown, in see-through detail). The user inserts his/her hand through the

opening defined by the free edge 220 when the user wishes to use the glove in the extended position as shown in FIGS. 8 and 9. As shown in FIG. 9, the glove portion 214 is sewn to the inner part of the sleeve 210 along seams 222. This affixes the glove portion 214 to the sleeve 210. As can also be seen in FIG. 9, the glove portion 214 includes attachment regions 226, 228. Again, attachment regions 226, 228 are positioned so that they lie adjacent to the heel of the hand and the palm of the hand of the user when the glove portion 214 is in the extended position. The attachment regions 226, 228 may have a puck attached thereto. In an alternative embodiment, attachment regions 226 and 228 may be combined into a single circular attachment region 230 (shown in dashed lines) since there is no need to split the attachment region since it doesn't fold, such as with line 122 of FIG. 6. When the glove portion 214 is not required to be used, the user withdraws his/her hand from the glove portion 214 and then folds the glove portion 214 about a line generally indicated by reference numeral 229 in FIG. 9 so that the glove portion 214 becomes neatly tucked up inside the sleeve 210. When the wearer wishes to go skateboarding, the glove portion 214 is folded out and the wearer extends his/her hand into the glove portion 214. The protective puck may then be attached.

[0051] FIG. 10 shows a jacket 250 having sleeves 210 as shown in FIGS. 8 and 9. The sleeve 210 shown on the left hand side of FIG. 10 has the glove portion 214 tucked away inside cuff 212 of the sleeve 210, whilst the other sleeve has the glove portion 214 in the extended position passing through cuff 212.

[0052] As can be seen from FIGS. 7 and 10, the garments having sleeves in accordance with embodiments of the present invention may be provided with one or more pockets. The one or more pockets may be used to store the pucks 36 that have been removed when the wearer is not skateboarding.

[0053] The present invention provides a garment or article of clothing that has a very conventional look when not being used for skateboarding, and yet can easily be converted to enable a puck or other protective device to be a fixed to the portion of the garment that overlies the heel of the hand or the palm of the wearer. The garment minimises or obviates the risk of losing sliding gloves. The garment allows easy attachment and release of protective pucks thereto.

[0054] Those skilled in the art will appreciate that the present invention may be susceptible to variations and modifications other than those specifically described. It will be understood that the present invention encompasses all such variations and modifications that fall within its spirit and scope.

We claim:

1. A garment comprising:
  - a sleeve including a cuff movable between a retracted position in which an end of the retracted cuff rests proximate the wrist of the user, and an extended position in which the end of the extended cuff extends over at least part of the hand of the user;
  - said cuff further comprising an attachment region, said attachment region being positioned adjacent to the palm, inner wrist or heel of the hand of the user when the cuff is in the extended position; and
  - a protective device attachable to said attachment region.
2. A garment as claimed in claim 1 wherein the cuff includes a thumb hole through which the thumb of a wearer can pass when the cuff is in the extended position.

3. A garment as claimed in claim 1 wherein the cuff includes a loop for extending around one or more fingers of the user.

4. A garment as claimed in claim 3 wherein the loop is located in a distal region of the extended cuff.

5. A garment as claimed in claim 4 wherein the loop comprises a loop of elasticised material that extends around a periphery of the distal end of the cuff so that positioning the loop over a finger of the user also acts to tighten the loop around the periphery of the end of the cuff.

6. A garment as claimed in claim 1 wherein the cuff has an adjustable size near the distal end of the cuff when the cuff is in the extended position.

7. A garment as claimed in claim 1 wherein the distal end of the cuff comprises a tubular portion having an opening at an end thereof.

8. A garment as claimed in claim 1 wherein the distal end of the cuff comprises a slit extending away from an opening towards the wrist of the user, and one or more closures for securing opposed sides or overlying sides of the slit to each other.

9. A garment as claimed in claim 1 wherein the attachment region comprises a hook and loop type fastener on the cuff.

10. A garment as claimed in claim 1 wherein the attachment region comprises an attachment means that is a fixed to the cuff.

11. A garment as claimed in claim 1 wherein the protective device comprises a protective device useful for facilitating longer more controlled slides during skateboarding.

12. A garment as claimed in claim 11 wherein the protective device comprises a puck.

13. A garment as claimed in claim 1 wherein the protective device includes a complementary attachment for attaching to the attachment region.

14. A garment having a sleeve, the sleeve including a glove portion attached at or near a distal end thereof, the glove portion being movable between a retracted position in which the glove portion lies within the sleeve to an extended position in which the glove portion extends from the sleeve and covers at least part of the hand of a user, the glove portion including an attachment region for attaching a protective device thereto, the protective device facilitating sliding during skateboarding by placing the protective device into contact with the ground, the protective device sliding over the ground whilst also providing protection to the hand of the user, the attachment region being exposed when the glove portion is in the extended position, the attachment region being positioned adjacent to the palm, inner wrist or heel of the hand of the user when the glove portion is in the extended position.

15. A garment as claimed in claim 14 wherein the glove portion includes at least a thumb receiving region and one or more finger receiving regions.

16. A garment as claimed in claim 15 wherein the glove portion has a cut-off thumb and fingers so that the thumb and fingers of the user extend through openings in the glove portion.

17. A garment as claimed in claim 14 wherein the glove portion is attached to an inner part of the sleeve.

18. A garment as claimed in claim 17 wherein only a part of the distal end of the glove portion is attached to the inner part of the sleeve to thereby leave an opening through the sleeve past the glove portion when the glove portion is in the retracted position.

19. A garment as claimed in claim 14 wherein the garment further comprises one or more pockets to store the protective device when the protective device has been removed from the cuff or glove portion of the garment.

20. A garment as claimed in claim 14 having a protective device removably attached to the attachment region, the protective device facilitating sliding during skateboarding by placing the protective device into contact with the ground, the protective device sliding over the ground whilst also providing protection to the hand of the user.

21. A garment as claimed in claim 1 wherein the garment further comprises one or more pockets to store the protective device when the protective device has been removed from the cuff or glove portion of the garment.

22. A garment as claimed in claim 1 having a protective device removably attached to the attachment region, the protective device facilitating sliding during skateboarding by placing the protective device into contact with the ground, the

protective device sliding over the ground whilst also providing protection to the hand of the user.

23. A garment having a sleeve, the sleeve including a cuff movable between a retracted position in which an end of the retracted cuff rests proximate the wrist of the user and an extended position in which the end of the cuff extends over at least part of the hand of the user, the cuff including an attachment region for attaching a protective device thereto, the protective device facilitating sliding during skateboarding by placing the protective device into contact with the ground, the protective device sliding over the ground whilst also providing protection to the hand of the user, the attachment region being exposed when the cuff is in the extended position, the attachment region being positioned adjacent to the palm, inner wrist or heel of the hand of the user when the cuff is in the extended position.

\* \* \* \* \*