



US00D894984S

(12) **United States Design Patent**
Okada et al.

(10) **Patent No.:** **US D894,984 S**

(45) **Date of Patent:** **** Sep. 1, 2020**

- (54) **TRANSPORTATION ROBOT**
- (71) Applicant: **OMRON CORPORATION**, Kyoto-shi,
Kyoto (JP)
- (72) Inventors: **Tomohiro Okada**, Shiga (JP); **Akiro Kobayashi**, Shiga (JP); **Shinji Kobayashi**, Nara (JP)
- (73) Assignee: **OMRON CORPORATION**, Kyoto (JP)
- (**) Term: **15 Years**
- (21) Appl. No.: **29/693,766**
- (22) Filed: **Jun. 5, 2019**

D712,447 S * 9/2014 He D15/199
 D841,067 S * 2/2019 Camporesi D15/199
 D843,427 S * 3/2019 Medal D15/199
 D852,250 S * 6/2019 Nabeiro D15/199
 2009/0035181 A1* 2/2009 Chung G01N 35/0099
 422/68.1
 2010/0145520 A1* 6/2010 Gerio G05B 19/425
 700/264
 2011/0077750 A1* 3/2011 Stummer G08C 17/00
 700/17
 2011/0135189 A1* 6/2011 Lee B25J 9/1682
 382/153
 2014/0074287 A1* 3/2014 LaFary G05D 1/0274
 700/253
 2014/0350725 A1* 11/2014 LaFary G06N 3/008
 700/253
 2015/0088359 A1* 3/2015 Choi G05D 1/0225
 701/23
 2019/0126470 A1* 5/2019 Oumi B25J 11/005

* cited by examiner

(30) **Foreign Application Priority Data**

Mar. 14, 2019 (JP) 2019-005357

(51) **LOC (12) Cl.** **15-99**

(52) **U.S. Cl.**
USPC **D15/199**

(58) **Field of Classification Search**

USPC D15/199; D21/578-583, 621, 622;
D32/21; D34/34

CPC B23K 9/133; B23K 9/287; B25J 9/0018;
B25J 19/0025; Y10T 74/20; Y10T
74/20207; Y10T 74/20311; Y10T
74/20305; Y10S 901/01

See application file for complete search history.

(56) **References Cited**

U.S. PATENT DOCUMENTS

D295,105 S * 4/1988 Dawson D34/18
 5,658,120 A * 8/1997 Watanabe B23Q 7/1436
 414/495
 D445,116 S * 7/2001 Evans D15/79
 D616,908 S * 6/2010 Labak D15/199

Primary Examiner — Patricia A Palasik
(74) *Attorney, Agent, or Firm* — Harness, Dickey & Pierce, P.L.C.

(57) **CLAIM**

The ornamental design for a transportation robot, as shown and described.

DESCRIPTION

FIG. 1 is a top, front, left perspective view of a transportation robot showing our new design;
 FIG. 2 is a front view thereof;
 FIG. 3 is a rear view thereof;
 FIG. 4 is a right side view thereof;
 FIG. 5 is a left side view thereof;
 FIG. 6 is a top view thereof; and,
 FIG. 7 is a bottom view thereof.

The broken lines in the figures show portions of the transportation robot that form no part of the claimed design.

1 Claim, 6 Drawing Sheets

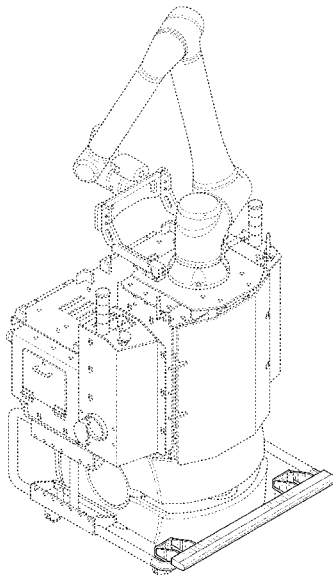

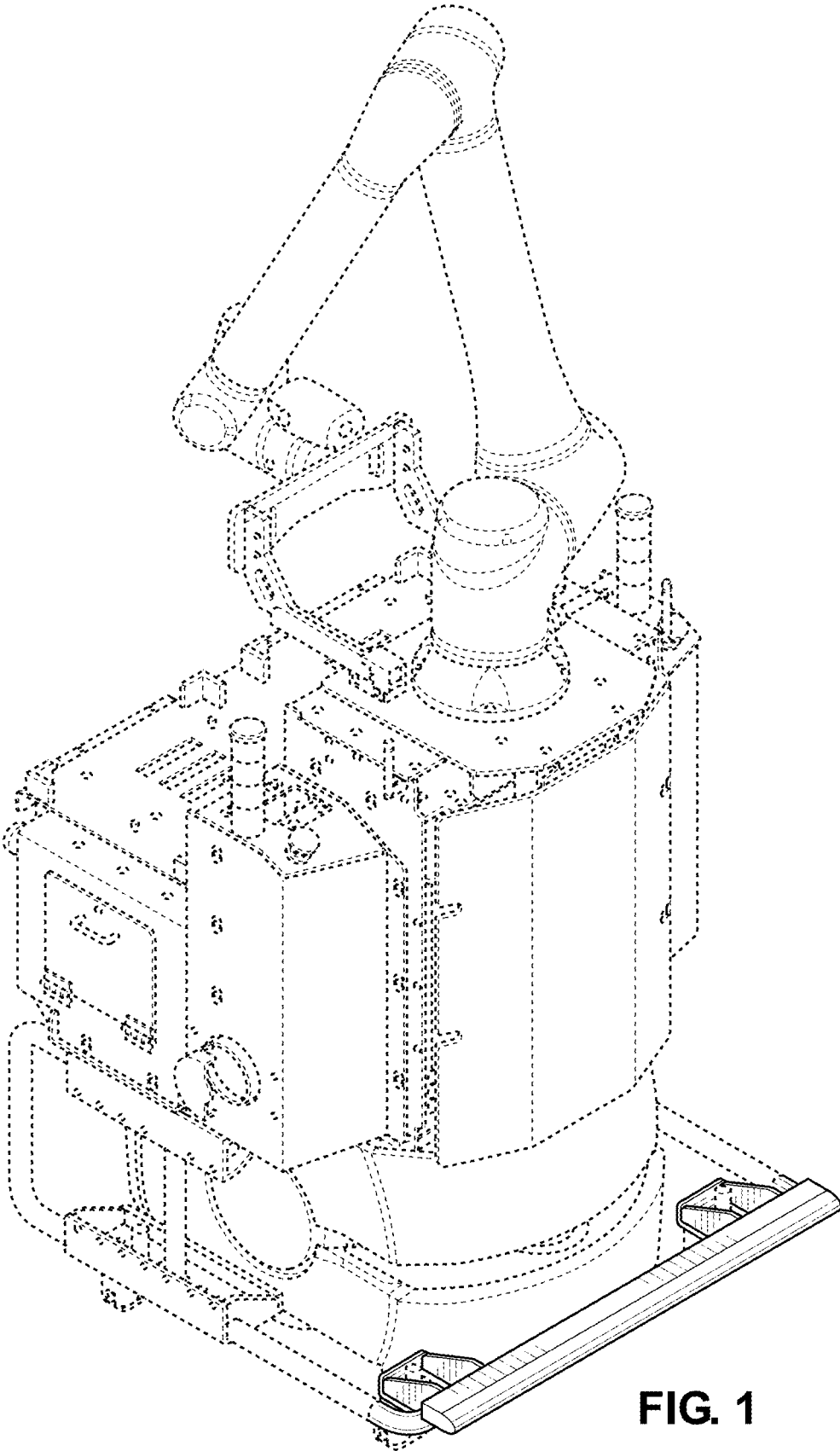

FIG. 1

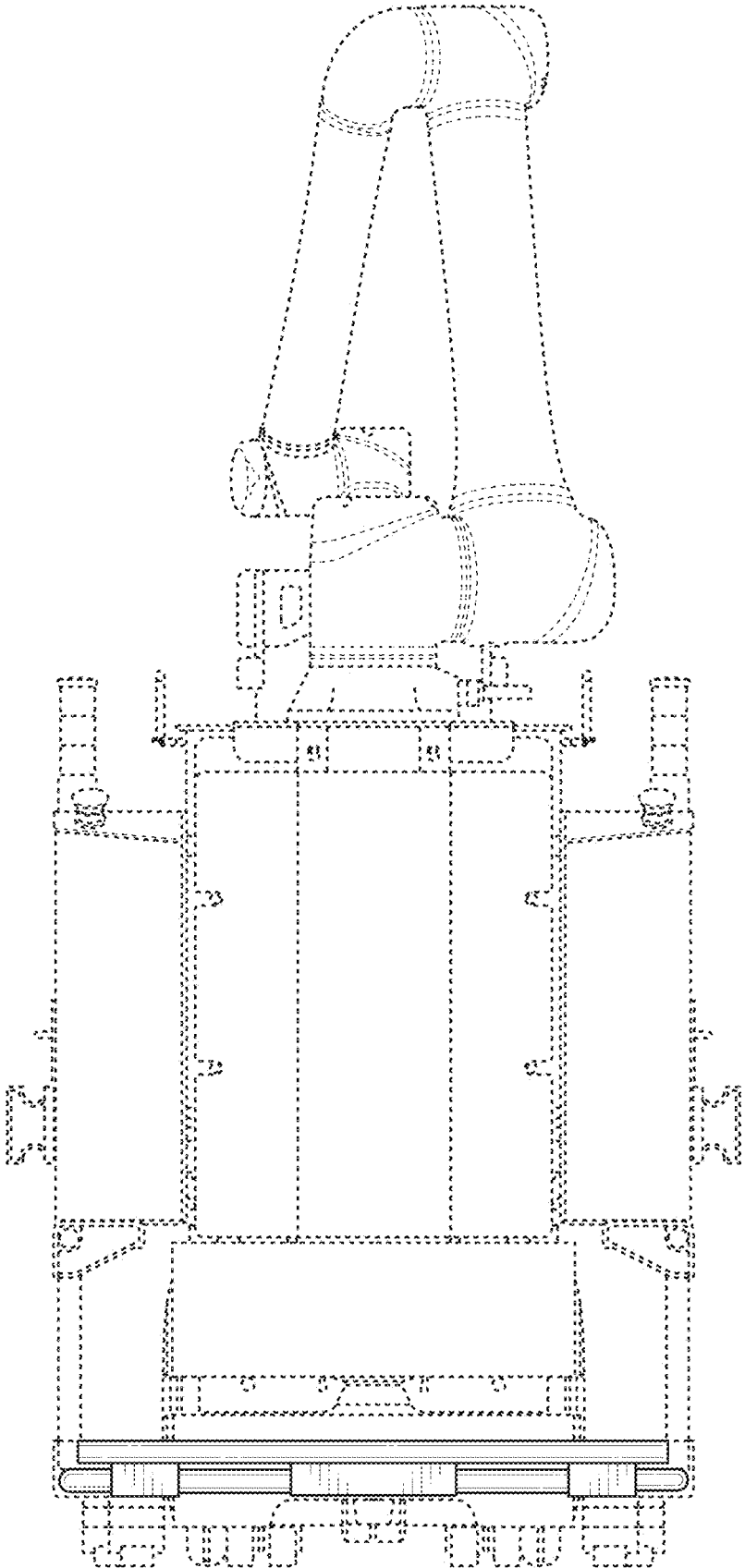

FIG. 2

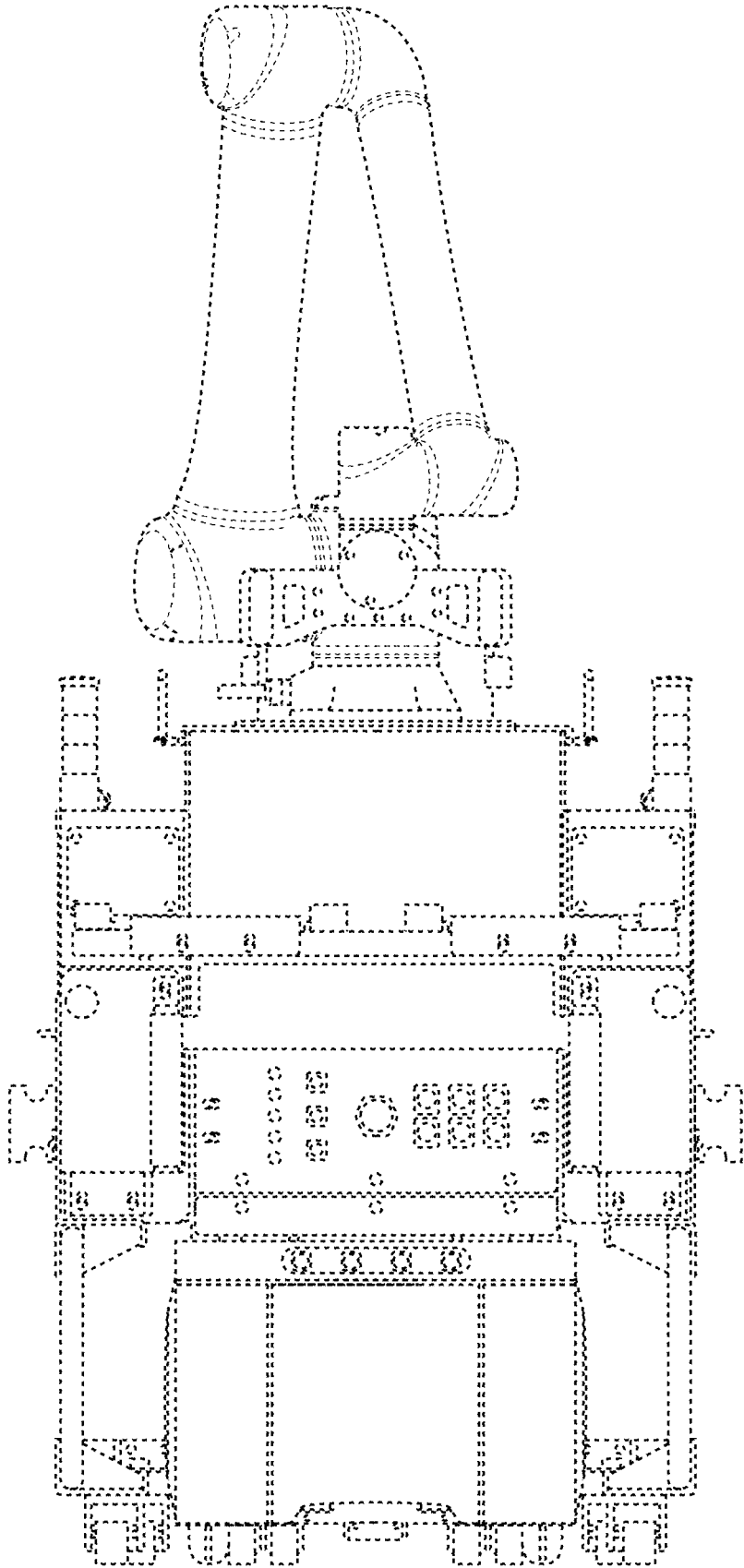

FIG. 3

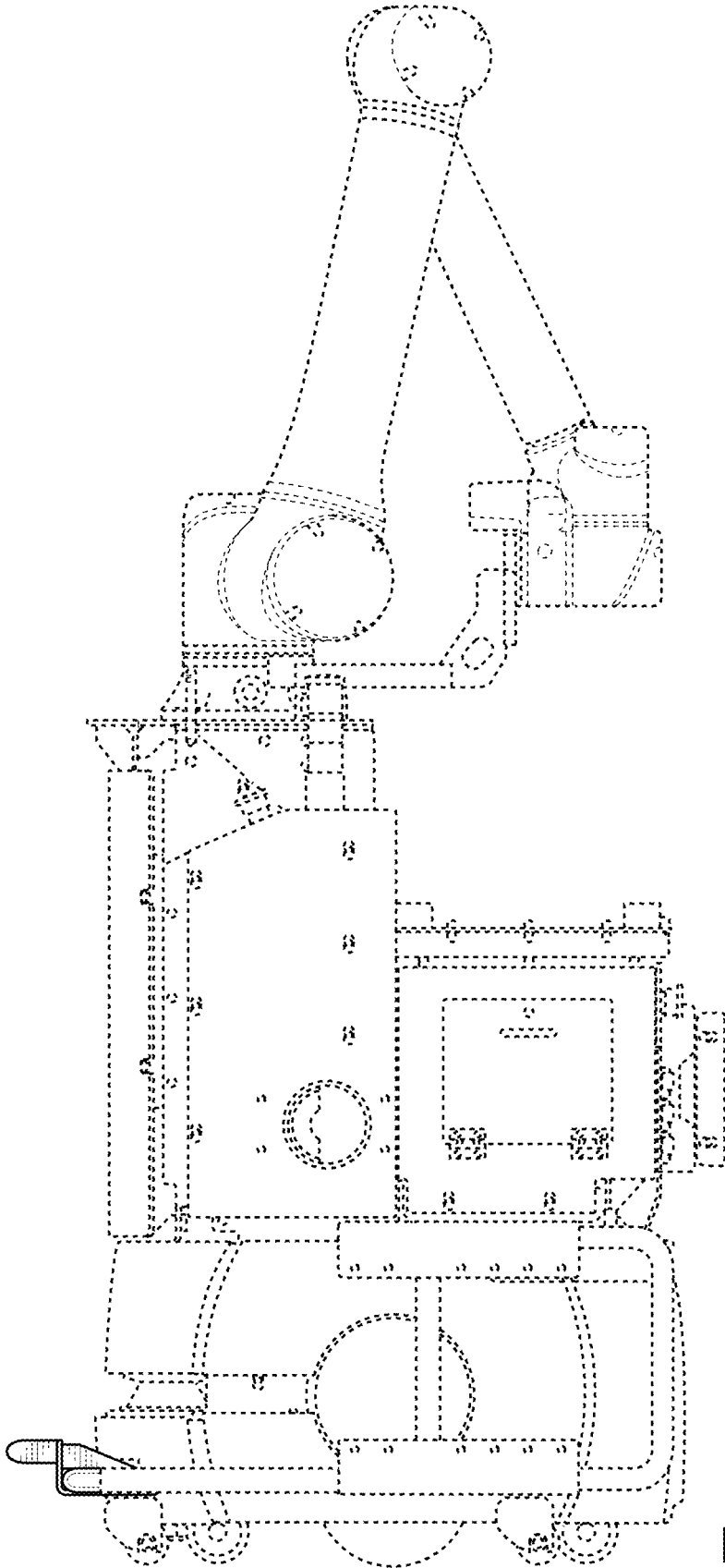

FIG. 4

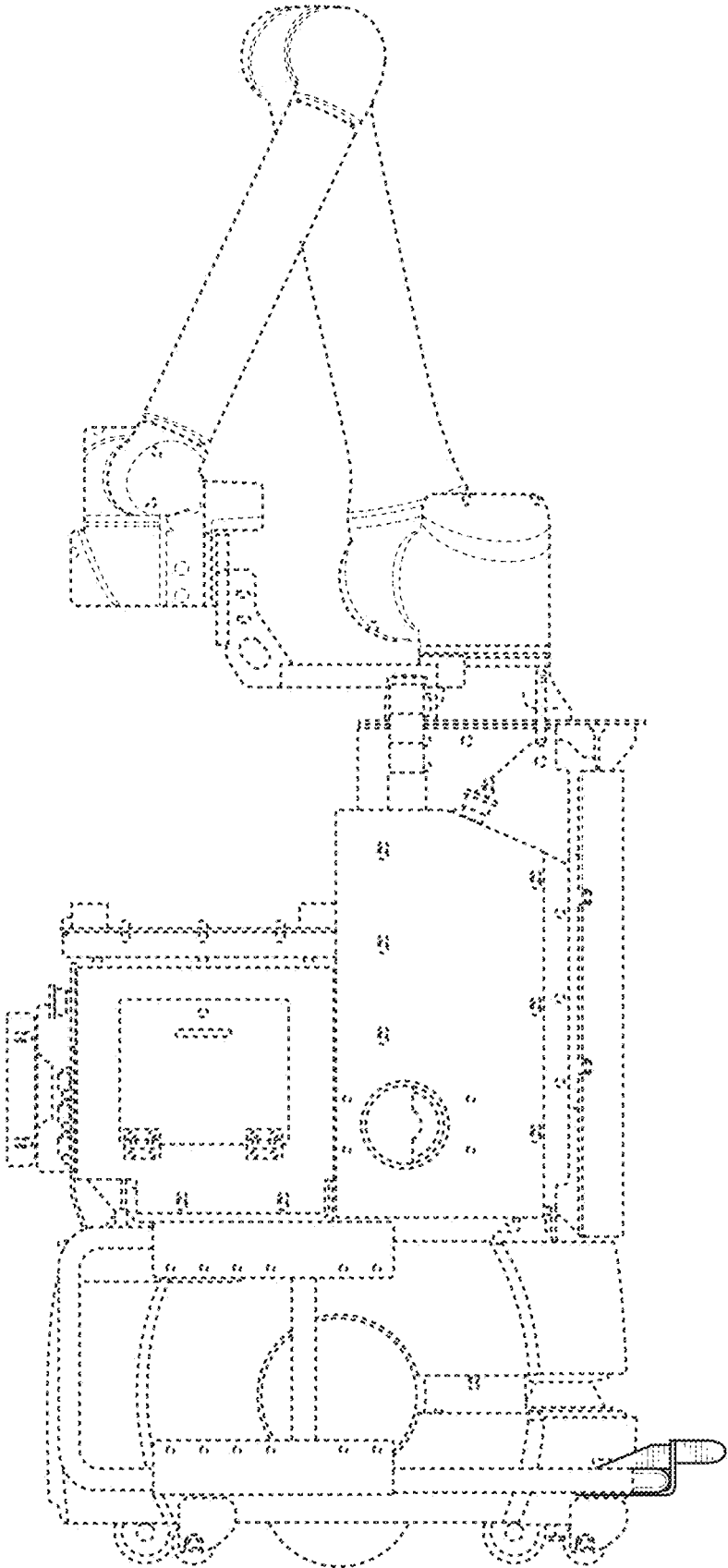

FIG. 5

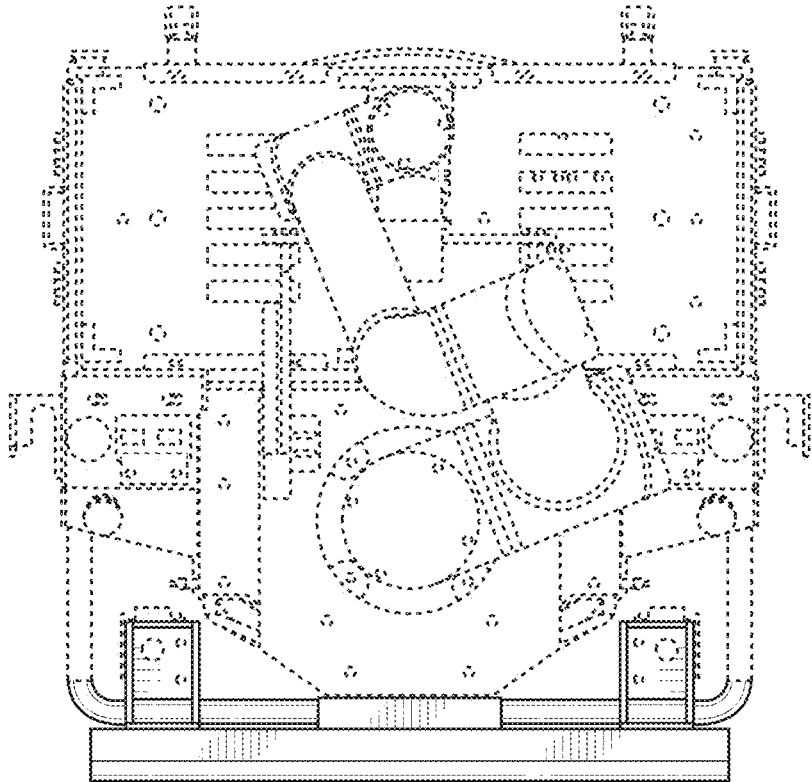

FIG. 6

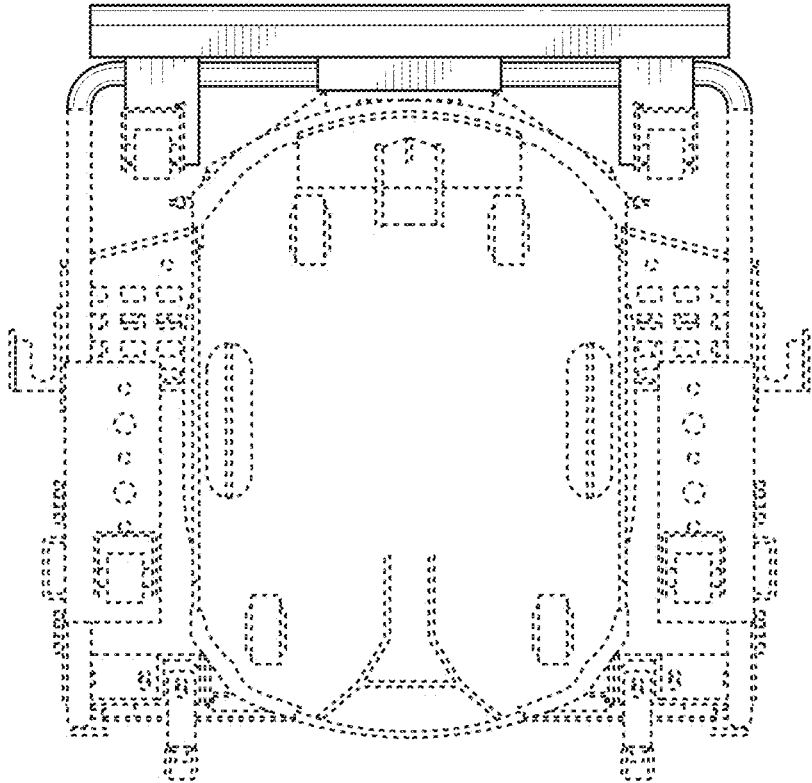

FIG. 7