

(19) World Intellectual Property Organization
International Bureau



(43) International Publication Date
28 October 2004 (28.10.2004)

PCT

(10) International Publication Number
WO 2004/093065 A1

- (51) International Patent Classification⁷: G11B 7/0045
- (21) International Application Number: PCT/KR2004/000862
- (22) International Filing Date: 14 April 2004 (14.04.2004)
- (25) Filing Language: English
- (26) Publication Language: English
- (30) Priority Data:
 - 10-2003-0023728 15 April 2003 (15.04.2003) KR
 - 10-2003-0023727 15 April 2003 (15.04.2003) KR
 - 10-2003-0023729 15 April 2003 (15.04.2003) KR
 - 10-2004-0017253 15 March 2004 (15.03.2004) KR
- (71) Applicant (for all designated States except US): SAM-SUNG ELECTRONICS CO. LTD. [KR/KR]; 416, Mae-tan-dong, Yeongtong-gu, Suwon-si, Gyeonggi-do 442-742 (KR).
- (72) Inventors: HWANG, Sung-Hee; 420-403 Jugong Apt., 189, Gaepo-dong, Gangnam-gu, Seoul 135-240 (KR). KO, Jung-Wan; 315-401 Daewoo Apt., 956-2, Cheongmyung Maoul 3-danji, Yeongtong-dong, Yeongtong-gu, Suwon-si, Gyeonggi-do 443-737 (KR).
- (74) Agent: LEE, Young-Pil; The Cheonghwa Building, 1571-18, Seocho-dong, Seocho-gu, Seoul 137-874 (KR).
- (81) Designated States (unless otherwise indicated, for every kind of national protection available): AE, AG, AL, AM, AT, AU, AZ, BA, BB, BG, BR, BW, BY, BZ, CA, CH, CN, CO, CR, CU, CZ, DE, DK, DM, DZ, EC, EE, EG, ES, FI, GB, GD, GE, GH, GM, HR, HU, ID, IL, IN, IS, JP, KE, KG, KP, KZ, LC, LK, LR, LS, LT, LU, LV, MA, MD, MG, MK, MN, MW, MX, MZ, NA, NI, NO, NZ, OM, PG, PH, PL, PT, RO, RU, SC, SD, SE, SG, SK, SL, SY, TJ, TM, TN, TR, TT, TZ, UA, UG, UZ, VC, VN, YU, ZA, ZM, ZW.
- (84) Designated States (unless otherwise indicated, for every kind of regional protection available): ARIPO (BW, GH, GM, KE, LS, MW, MZ, SD, SL, SZ, TZ, UG, ZM, ZW), Eurasian (AM, AZ, BY, KG, KZ, MD, RU, TJ, TM), European (AT, BE, BG, CH, CY, CZ, DE, DK, EE, ES, FI, FR, GB, GR, HU, IE, IT, LU, MC, NL, PL, PT, RO, SE, SI, SK, TR), OAPI (BF, BJ, CF, CG, CI, CM, GA, GN, GQ, GW, ML, MR, NE, SN, TD, TG).

Published: with international search report

[Continued on next page]

(54) Title: RECORDING/REPRODUCING METHOD, RECORDING/REPRODUCING APPARATUS AND OPTICAL RECORDING MEDIUM

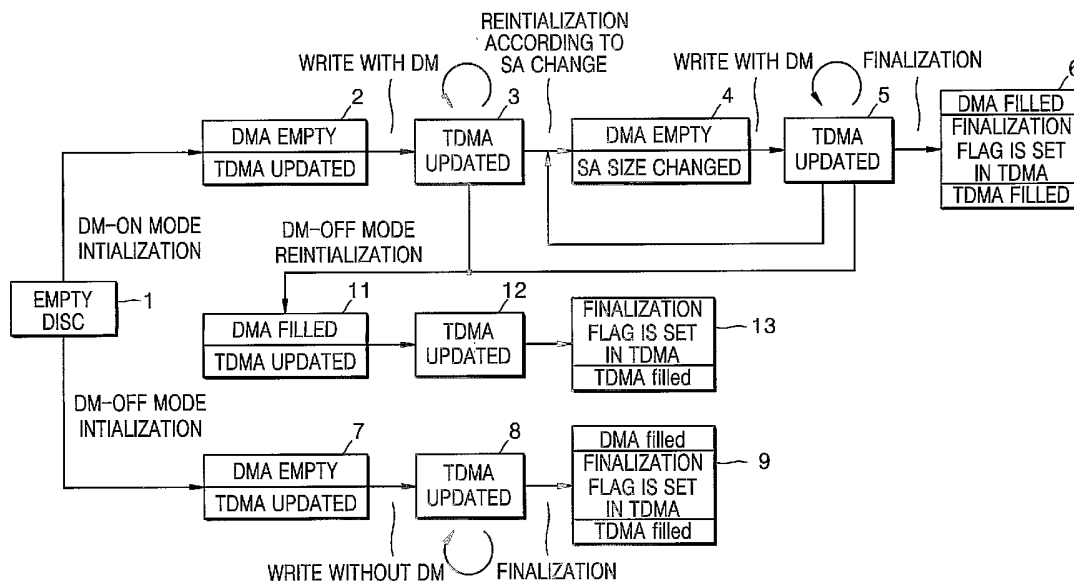

(57) Abstract: A recording method for use by an apparatus and/or which is encoded on a computer readable medium includes selecting a defect management on mode or a defect management off mode that indicates whether defect management is to be performed or not while data is recorded in the recording medium, recording the data in the recording medium while defect management is performed on the recording medium, if the defect management on mode is selected, and recording the data in the recording medium without defect management, if the defect management off mode is selected.

WO 2004/093065 A1



For two-letter codes and other abbreviations, refer to the "Guidance Notes on Codes and Abbreviations" appearing at the beginning of each regular issue of the PCT Gazette.

RECORDING/REPRODUCING METHOD, RECORDING/REPRODUCING APPARATUS AND OPTICAL RECORDING MEDIUM

Technical Field

5 The present invention relates to the field of discs, and more particularly, to a recording/reproducing method, a recording/reproducing apparatus, an optical recording medium, and a computer readable recording medium having recorded thereon a program for the recording/reproducing method.

10 Background Art

 Recent years have witnessed remarkable advances in optical recording techniques (i.e., techniques for recording data on optical discs). With these advances, various types of optical disc recording/reproducing apparatuses have been developed.

 Write-once optical discs are a type of optical discs to which data can be written
15 only once. For example, conventional compact disc-recordables (CD-Rs) and digital versatile disc-recordables (DVD-Rs) are forms of the write-once optical discs. Generally, in the write-once optical discs, a state of a recording layer is changed by applying heat to a predetermined area of the recording layer using laser light to form a recording mark.

20 Defect management involves re-writing user data, which has been recorded in a user data area where a defect is generated, thereby compensating for data loss otherwise caused by the generation of the defect. Conventionally, defect management is classified into defect management using a linear replacement method and defect management using a slipping replacement method. In the linear
25 replacement method, an area of a user data area where a defect is generated is replaced with an area of a spare area where a defect is not generated. In the slipping replacement method, the area where a defect is generated is slipped without using such an area and a next area where a defect is not generated is used.

 In the case of the linear replacement method, a block of the user data area
30 where a defect is generated is called a defect block and the spare area, which is a space for a replacement block for replacement of the defect block, is provided in a

predetermined area of a disc.

Since the write-once optical discs cannot be overwritten, defect management methods different from those in rewritable discs may be adopted. In the case of the write-once optical discs, the above-described defect management methods may or may not be used. Thus, there is a need for a method of using the write-once optical discs based on whether defect management is used or not.

Disclosure of the Invention

An aspect of the present invention provides a recording/reproducing method, a recording/reproducing apparatus, an optical recording medium, and a computer readable recording medium having recorded thereon a program for the recording/reproducing method, in which a write-once optical disc can be used according to whether defect management is adopted or not.

Additional aspects and/or advantages of the invention will be set forth in part in the description which follows and, in part, will be obvious from the description, or may be learned by practice of the invention.

According to an aspect of the present invention, a method of recording data on a recording medium comprises selecting a defect management mode selectable between a defect management on mode and a defect management off mode that indicates whether defect management is to be performed on the recording medium; recording the data on the recording medium while defect management is performed on the recording medium, if the defect management on mode is selected; and recording the data in the recording medium without defect management, if the defect management off mode is selected.

According to an aspect of the invention, the recording of the data in the defect management on mode comprises initializing the recording medium to the defect management on mode, the initialization comprising assigning a spare area for replacing a defect generated in a data area of the recording medium to the data area; and recording temporary defect management information including information on the assigned spare area and an identifier indicating the defect management on mode, in a temporary defect management area provided in the recording medium.

According to an aspect of the invention, the recording of the data in the defect

management on mode further comprises recording a replacement block, which replaces a defect block concerning the defect generated in the data area, in the spare area in predetermined operation units; and updating the information on the defect and the defect management information for defect management as temporary defect management information in the temporary defect management area in predetermined operation units.

According to an aspect of the invention, the recording of the data in the defect management on mode further comprises changing a size of the spare area; and updating temporary defect management information including information on the changed size of the spare area in the temporary defect management area.

According to an aspect of the invention, the recording of the data in the defect management on mode further comprises converting the defect management on mode into the defect management off mode.

According to an aspect of the invention, the conversion into the defect management off mode comprises reinitializing the recording medium to the defect management off mode; and recording the data in the recording medium without defect management.

According to an aspect of the invention, the reinitialization to the defect management off mode comprises recording the identifier indicating the defect management off mode in the temporary defect management area; and recording temporary defect management information that is finally updated in the temporary defect management area in a defect management area provided in the recording medium.

According to an aspect of the invention, the recording method further comprises finalizing the recording medium, where the finalization of the recording medium comprises recording a finalization flag indicating the finalization of the recording medium in the temporary defect management area; recording temporary defect management information including finally updated information on the defect and defect management information in the temporary defect management area in a defect management area provided in the recording medium; and filling with predetermined data a remaining area of the temporary defect management area where the data is not recorded.

According to an aspect of the invention, the recording of the data in the defect management off mode comprises recording the data in the data area provided in the recording medium in predetermined operation units; and updating recording management information according to the recording of the data in a temporary defect management area provided in the recording medium.

According to an aspect of the invention, the recording method further comprises finalizing the recording medium, where the finalization of the recording medium comprises recording a finalization flag, which indicates the recording medium is finalized, in the temporary defect management area; recording recording management information finally updated in the temporary defect management area in a defect management area provided in the recording medium; and filling with predetermined data a remaining area of the temporary defect management area where no data was recorded.

According to another aspect of the present invention, a method of reproducing data recorded on a recording medium, which includes a lead-in area, a data area, and a lead-out area consecutively arranged, comprises reading defect management on/off mode information, which indicates whether defect management was performed on the recording medium, from a temporary defect management area provided in the lead-in area or the lead-out area, so as to update information on a defect generated in the data area and defect management information for management of the defect for every predetermined operation and reading data recorded in the data area based on the read defect management on/off mode information.

According to an aspect of the invention, the reproducing method further comprises reading finally updated information on the defect and finally updated defect management information from the temporary defect management area, if the read defect management on/off mode information is a defect management on mode.

According to an aspect of the invention, the reproducing method further comprises reading a finalization flag, which indicates the recording medium is finalized, from the temporary defect management area; and reading the finally updated information on the defect and the finally updated defect management information from a defect management area provided in the recording medium.

According to an aspect of the invention, the reproducing method further

comprises reading final recording management information from the temporary defect management area, if the read defect management on/off mode information is a defect management off mode.

According to an aspect of the invention, the reproducing method further
5 comprises reading the finalization flag, which indicates the recording medium is finalized, from the temporary defect management area; and reading the finally updated information on the defect and the finally updated defect management information from the defect management area provided in the recording medium.

According to another aspect of the present invention, an apparatus for
10 reproducing and/or recording data on a recording medium comprises a recording/reading unit, which transfers the data with respect to the recording medium; and a control unit, which selects a defect management mode as one of a defect management on mode and a defect management off mode that indicates whether defect management is to be performed while data is recorded on the recording medium,
15 and controls the recording/reading unit to record the data in the recording medium while defect management is performed on the recording medium, if the defect management on mode is selected and record the data in the recording medium without defect management, if the defect management off mode is selected.

According to another aspect of the present invention, an apparatus for recording
20 and/or reproducing data recorded on a recording medium, which includes a lead-in area, a data area, and a lead-out area consecutively arranged, comprises a reading unit, which transfers data with respect to the recording medium; and a control unit, which controls the reading unit to read defect management on/off mode information, which indicate whether defect management was performed on the recording medium,
25 from a temporary defect management area provided in the lead-in area or the lead-out area, so as to update information on a defect generated in the data area and defect management information for management of the defect for every predetermined recording operation, and controls the reading unit to read data recorded in the data area based on the read defect management on/off mode information.

According to another aspect of the present invention, an optical recording
30 medium includes a lead-in area, a data area, and a lead-out area consecutively arranged, a temporary defect management area for recording temporary information on

a defect generated in the data area, where the lead-in area or the lead-out area and temporary defect management information are for management of the defect, and a defect management area for recording final information on the defect and final defect management information and which are in the lead-in area or the lead-out area, where
5 the temporary defect management information recorded in the temporary defect management area includes defect management on/off mode information that indicates to a recording and/or reproducing apparatus whether data is to be recorded on the recording medium while defect management is performed on the recording medium.

According to an aspect of the invention, if the recording medium is initialized to
10 the defect management on mode, a spare area is assigned to the data area by the apparatus for recording a replacement block that replaces a defect block concerning a defect generated in the data area of the recording medium in predetermined recording operation units, the defect management area is empty, and the temporary defect management area enters a state where the information on the defect and the defect
15 management information for management of the defect can be updated in predetermined recording operation units.

According to an aspect of the invention, if the size of the spare area of the recording medium is changed and the recording medium is reinitialized, information on
the changed size of the spare area is recorded in the temporary defect management
20 area.

According to an aspect of the invention, if the recording medium is reinitialized to a defect management off mode, information indicating the defect management off mode is recorded in the temporary defect management area and temporary defect management information finally updated in the temporary defect management area is
25 recorded in the defect management area.

According to an aspect of the invention, when the recording medium is finalized, a finalization flag, which indicates the recording medium is finalized, is recorded in the temporary defect management area, temporary defect management information finally recorded in the temporary defect management area is recorded in the defect
30 management area, and predetermined data fills in a remaining area of the temporary defect management area where no data is recorded.

According to an aspect of the invention, if the recording medium is initialized to

the defect management off mode, the defect management area is empty and the temporary defect management area enters a state where recording management information according to the recording of the data in the data area can be updated in predetermined recording operation units.

5 According to another aspect of the present invention, a computer readable recording medium encoded with programming instructions for implementing a method of recording data on a recording medium performed by a computer, the method comprising selecting a defect management mode as one of a defect management on mode and a defect management off mode that indicates whether defect management
10 is to be performed on the recording medium; recording the data in the recording medium while defect management is performed on the recording medium, if the defect management on mode is selected; and recording the data in the recording medium without defect management, if the defect management off mode is selected.

 According to another aspect of the present invention, a computer readable
15 recording medium encoded with processing instructions for implementing a method of reproducing data recorded on a recording medium, which has a lead-in area, a data area, and a lead-out area consecutively arranged, as performed by a computer the method comprising reading defect management on/off mode information, which indicates one of whether defect management is performed on the recording medium
20 and whether defect management is not performed, from a temporary defect management area provided in the lead-in area or the lead-out area, so as to update information on a defect generated in the data area and defect management information for management of the defect for every predetermined recording operation and reading data recorded in the data area based on the read defect management on/off mode
25 information.

Brief Description of the Drawings

FIG. 1 is a state diagram of a write-once recording medium according to an embodiment of the present invention;

30 FIG. 2 is a data structure diagram of a single recording layer recording medium according to an embodiment of the present invention;

 FIG. 3 is a data structure diagram of a double recording layer recording medium

according to an embodiment of the present invention;

FIG. 4 is a detailed data structure diagram of areas of the write-once recording medium according to an embodiment of the present invention;

FIG. 5 is a view for explaining temporary disc management information recorded
5 in a temporary disc management area according to an embodiment of the present invention;

FIG. 6 is a view for explaining temporary disc management information recorded in a temporary disc management area according to an embodiment of the present invention;

FIG. 7 is a detailed data structure diagram of a temporary defect definition structure (TDDS) # i of the temporary disc management information according to an
10 embodiment of the present invention;

FIG. 8 is a detailed data structure diagram of a space bit map (SBM) # i of the temporary disc management information according to an embodiment of the present
15 invention;

FIG. 9 is a detailed data structure diagram of a temporary defect list (TDFL) # i of the temporary disc management information according to an embodiment of the present invention;

FIG. 10 is a data structure diagram of a defect list entry # i shown in FIG. 9;

FIG. 11 is a schematic block diagram of a recording/reproducing apparatus
20 according to an embodiment of the present invention;

FIGS. 12A through 12E are flowcharts illustrating a method of using the write-once recording medium in a defect management (DM)-on mode or a DM-off mode according to an embodiment of the present invention; and

FIG. 13 is a reference view for explaining a process of defect management
25 according to an embodiment of the present invention.

Best mode for carrying out the Invention

Reference will now be made in detail to the present embodiments of the present
30 invention, examples of which are illustrated in the accompanying drawings, wherein like reference numerals refer to the like elements throughout. The embodiments are described below in order to explain the present invention by referring to the figures.

FIG. 1 is a state diagram of a write-once recording medium according to an aspect of the present invention and shows the life of the write-once recording medium ranging from initialization to finalization according to a DM-on mode or a DM-off mode. The write-once recording medium according to an aspect of the present invention can be used in two modes according to whether defect management is used or not. The first mode is the DM-on mode in which data is recorded on a recording medium while defect management is performed on the recording medium. The second mode is the DM-off mode in which data is recorded on a recording medium while defect management is not performed.

In the DM-on mode, a spare area is assigned to a data area provided on a recording medium and data is recorded by a drive device on the recording medium while defect management and is performed with the intention of a user or a drive manufacturer. In the DM-off mode, data is recorded by a drive device on a recording medium without defect management, where the recording is performed with the intention of a user or a drive manufacturer. Since the spare area assigned to a part of the data area is provided for defect management and since to defect management is performed in the DM-off mode, it is natural that a spare area be not assigned in the DM-off mode. While FIG. 1 is shown without a reinitialization from the DM-off mode to the DM-on mode, it is understood that such a reinitialization from the DM-off mode to the DM-on mode is possible to the extent that the DMA is not filled prior to finalization.

DM-on mode

The life of the write-once optical medium according to the DM-on mode is shown in an upper part of FIG. 1. In the following description, terms "disc" and "recording medium" are interchangeable and are not limited to a specific type of medium. When a disc manufactured by a disc manufacturer is first used, the disc is an empty disc 1 on which no data is written. However, the empty disc 1 includes a lead-in area, a data area, and a lead-out area that are assigned during disc manufacturing. The structure of the empty disc 1 is shown in FIGs. 2 and 3. The spare area shown in FIGs. 2 and 3 are not assigned during disc manufacturing, but are assigned during disc initialization. Also, assignment of the spare area depends on whether defect management is performed on the disc 1 or not. Thus, the spare area is represented using dotted lines.

If it is determined that the empty disc 1 is to be used according to the DM-on mode, the empty disc 1 is initialized to the DM-on mode. For defect management, the spare area is assigned to the data area of the empty disc 1 and initialization information for defect management is recorded in a predetermined area of the empty disc 1.

5 Assignment of the spare area will be described with reference to FIGs. 2 and 3.

FIG. 2 is a data structure diagram of a single recording layer recording medium version of the disc 1 according to an aspect of the invention. Referring to FIG. 2, a lead-in area, a data area, and a lead-out area are provided in succession in the single recording layer. The lead-in area, the data area, and the lead-out area are assigned during disc manufacturing. If defect management by a drive device is performed on the disc 1 during initialization for use of the disc 1, a spare area is assigned to the data area. Referring to FIG. 2, two spare areas are assigned to the data area and the data area includes a spare area #1, a user data area, and a spare area #2. Data recording begins in a location having a logical sector number (LSN) 0 of the user data area and progresses towards a location having the last LSN. While not required in all aspects, the spare area #2 is used after the spare area #1 is completely written to (i.e., filled). In the spare area #2, if recording progresses in the direction from the lead-out area to the user data area, size change of the spare area #2 like extension or reduction can be easily performed.

20 FIG. 3 is a data structure diagram of a double recording layer recording medium version of the disc 1 according to an aspect of the present invention. The structure of the double recording layer recording medium is similar with that of the single recording layer recording medium 1 shown in FIG. 2. One layer of the double recording layer recording medium 1 includes a lead-in area #0, a data area #0, and a lead-out area #0 in succession. The other layer includes a lead-in area #1, a data area #1, and a lead-out area #1 in succession. It is determined that defect management by a drive device is to be performed during disc initialization. Thus, the spare areas #1 and #2 are assigned to the data area #0, and spare areas #3 and #4 are assigned to a data area #1. In other words, the data area #0 includes the spare area #1, the user data area #0, and the spare area #2 and the data area #1 includes the spare area #3, the user data area #1, and the spare area #4. To facilitate extension of the spare area #4, it is desirable, but not required to use the disc 1 such that an LSN increases in the

direction from the user data area #0 to the user data area #1, as shown in FIG. 4.

The detailed structures of the lead-in area and lead-out area of the recording medium 1 shown in FIGs. 2 and 3 will be described with reference to FIG. 4. FIG. 4 is a detailed data structure diagram of areas of the write-once recording medium 1 according to an aspect of the present invention. Referring to FIG. 4, as described above, the write-once recording medium 1 includes the lead-in area, the data area, and the lead-out area in succession and the spare areas #1 and #2 are assigned to the data area during disc initialization for defect management. The lead-in area includes a defect management area (DMA) #1, a drive information area, a temporary defect management area (TDMA), a recording condition test area, and a DMA #2. The lead-out area includes a DMA #3 and a DMA #4. Naturally, detailed areas assigned to the lead-in area can also be assigned to the lead-out area in addition to or instead of the lead-in area.

The spare areas #1 and #2 are provided to rewrite data in a replacement block that replaces a block of the user data area when a defect is generated in the data recorded in the user data area. The drive information area is provided to record information on a drive device that loads a disc and records data in or reads data from the disc 1. The recording condition test area is provided to allow the drive device to perform a predetermined test for the purpose of searching for the optimal condition for recording/reproducing data in the loaded disc.

The DMA is provided to record defect information and defect management information (DMI). The DMA includes a disc definition structure (DDS) for the DMI and a defect list (DFL) for the defect information and is provided for compatibility with rewritable recording media or to read and record final defect information and DMI recorded in the TDMA during disc finalization.

The TDMA is written to while temporary defect management information is updated. The temporary defect management information includes the temporary defect definition structure, a space bit map (SBM) that indicates recording or non-recording in blocks of a physical available space of a disc using bit values, and a temporary defect list (TDFL) for the temporary defect information. In other words, the TDMA is provided to record temporary defect management information (TDMI) including temporary disc definition structure (TDDS), the SBM, and the TDFL.

The TDMA is specially prepared to implement defect management by a drive device in the write-once recording medium. Specifically, in rewritable recording media, the DMA is only provided and the TDMA is not additionally provided. This is because the write-once recording medium cannot be overwritten as can a rewritable medium.

5 Unlike rewritable recording media, since the write-once recording medium cannot be overwritten when the DMI is to be updated, a new area where updated information is to be written is required. Thus, a relatively large number of areas are required in proportion to the number of times the DMI is updated. However, since the DMA is not large in rewritable recording media, the TDMA is additionally provided in the write-once

10 recording medium and the DMI is updated in the TDMA. Also, during disc finalization, finally updated TDMI in the TDMA (i.e., the TDMI as of a last recording operation) is recorded in the DMA as the DMI. By recording the DMI in the DMA provided in the write-once recording medium, compatibility with rewritable recording media can be achieved. For convenience of explanation, the DMI updated in the TDMA is referred

15 to as "TDMI" and final TDMI recorded in the DMA is referred to as "DMI".

Hereafter, the TDMI recorded in the TDMA will be described in detail. The TDMI includes the TDDS, the SBM, and the TDFL. When the TDDS, the SBM, and the TDFL are recorded in the TDMA, the TDDS and the SBM may be recorded in the same block and the TDFL may be recorded in another block. For example, as shown

20 in FIG. 5, the TDMI includes a TDMI #0 composed of a TDFL #0, a TDDS #0, and an SBM #0 and can be updated in units of TDMI # i in the TDMA. As another example, as shown in FIG. 6, the TDMA is divided into two parts, a TDDS # i and an SBM # i may be updated as one block in one part, and a TDFL # i may be updated as one block in another part. The detailed structure of the TDDS # i will be described with

25 reference to FIG. 7.

FIG. 7 is a detailed data structure diagram of the TDDS # i of the TDMI according to an aspect of the present invention. Referring to FIG. 7, the TDDS # i includes starting location information of the user data area, ending location information of the user data area, size information of the spare area #1, size information of the

30 spare area #2, a TDFL pointer, a recording condition test available location pointer, a finalization flag, and a DM mode.

The location and size of the user data area assigned to the data area and the

locations of the spare areas #1 and #2 can be obtained from the starting location information of the user data area and the ending location information of the user data area. The size location of the spare area #1 and the size information of the spare area #2 are recorded as the TDDS and the size information of the spare area #1 or #2 is changed if the spare area #1 or #2 is enlarged or reduced. The TDFL pointer indicates location information of a recently updated TDFL. By using the TDFL pointer, a finally updated TDFL can be easily found.

The recording condition test available location pointer indicates location information of the recording condition test area provided in the lead-in area or the lead-out area of the disc, in which a test can be performed. By referring to the recording condition test available location pointer, a location where a test can be performed can be easily found without direct scanning of the recording condition test area.

The finalization flag is a flag for setting disc finalization and it is possible to determine using the finalization flag whether a disc is finalized or not. Although the finalization flag is provided in the TDDS # i in FIG. 7, the finalization flag may be provided in the SBM # i as shown in FIG. 8.

A DM mode of FIG. 7 indicates whether defect management is performed on a corresponding disc 1 or not. For example, when data is recorded on the disc while defect management is performed on the disc 1, the DM mode is set to the DM-on mode, and when data is recorded on the disc 1 while defect management is not performed, the DM mode is set to the DM-off mode.

FIG. 8 is a detailed data structure diagram of the SBM # i of temporary disc management information according to an aspect of the present invention. Referring to FIG. 8, the SBM # i includes an SBM header and a bit map. The SBM header is an identifier indicating the SBM. The bit map is an information map that indicates recording or non-recording in a block of a physically recordable area of the disc using bit values. For example, a block where data is recorded is represented by "1" and a block where data is not recorded is represented by "0". In this way, it is possible to know recording or non-recording in each block.

FIG. 9 is a detailed data structure diagram of the TDFL # i of the temporary disc management information according to an aspect of the present invention. Referring to

FIG. 9, the TDFL # i includes a TDFL header, a defect list entry #0, a defect list entry #1, The TDFL header is an identifier indicating the TDFL. The defect list entry # i indicates information on a defect generated in the user data area. FIG. 10 shows a data structure of the defect list entry # i shown in FIG. 9.

5 Referring to FIG. 10, the defect list entry # i includes state information, a defect block physical address, and a replacement block physical address. The defect block physical address indicates a physical address of a defect block of the user data area and the replacement block physical address indicates a physical address of a replacement block of the spare area, which replaces the defect block. The state
10 information indicates if the replacement information and consecutive defect information.

The replacement information indicates whether the defect block has a replacement block. In other words, there is a state of the defect block having a replacement block and a state of the defect block having no replacement block. The consecutive defect
15 information indicates a state of the defect block when a defect generated in the user data area is generated in consecutive blocks. In other words, when a defect is generated in consecutive blocks in the user data area, a defect list entry for each of the consecutive blocks is not made, but the first defect entry of the first defect block among the consecutive blocks and the last defect entry of the last defect block among the consecutive blocks are only made. Thus, it is possible to save the space of the TDFL.

20 Here to, an exemplary structure of a recording medium to which the present invention can be applied is described. Referring back to FIG. 1, after initialization to the DM-on mode of the empty disc 1, the DMA of the disc is empty and the TDMA enters a state 2 where the TDMA can be updated. Update of the TDMA indicates that the TDMI is updated in the TDMA. Such update is performed in units of
25 predetermined recording operation that may be one verify-after-write unit or a plurality of verify-after-write units in which a block is recorded and then verified or eject units according to an aspect of the invention. Here, a block means an error correction code (ECC) unit recorded in the disc. However, it is understood that other update methods can be used and/or performed other than in units of recording operations.

30 Data is recorded in the disc 1 of the state 2 while defect management by a drive device is performed on the disc. Then, the TDMA as shown in FIG. 4 maintains a state 3 where the TDMI is updated according to data recording simultaneously with

defect management. While using the disc 1 of the state 3, if any change occurs in the spare area, the disc 1 is reinitialized, the size information of the spare area of the TDMI is changed, the changed size information of the spare area is recorded in the TDMA, and the DMA is still empty. If the spare area assigned during disc initialization is entirely consumed and the spare area needs to be enlarged, or if the user data area lacks an area that data is to be written to and the spare area needs to be reduced, the size information of the spare area is changed during use of the disc 1 (state 4). The TDDS # i including such changes is recorded in the TDMA. Even after the size of the spare area is changed, data is recorded in the disc 1 while defect management by the drive device is performed on the disc, and the TDMA is updated (state 5).

The disc 1 may be reinitialized to the DM-off mode during data recording simultaneously with defect management. When the disc 1 is reinitialized to the DM-off mode, for compatibility with rewritable recording media, final TDDS and TDFL information recorded in the TDMA are recorded as DDS and DFL information in the DMA and the TDMA is changed into the DM-off mode. In other words, an update is made in the TDDS shown in FIG. 7 by setting the DM mode to the DM-off mode and finally updated TDDS # n and TDFL # n in the TDMA are copied and recorded in the DMA (states 11 through 13).

Specifically, after being reinitialized to the DM-off mode, the DMA of the disc 1 is filled in and the TDMA enters the state 11 where the TDMA can be updated. Since the DM mode is changed into the DM-off mode, data is recorded without defect management and the TDMA is updated (state 12). Since defect management is not performed, the update of the TDMA mainly concerns the TDDS # i and the SBM # i. However, if contents unrelated to defect management are included in the TDFL # i, the TDFL # i may also be updated. While the disc 1 is used in this way, if the disc 1 is finalized, the TDMA is filled in and enters the state 13 where the finalization flag is set in the TDMA (state 13).

While data is recorded in the disc of the state 5 and defect management by the drive device is performed on the disc 1, if the disc is finalized, the finalization flag is set in the TDMA to prevent the disc from being used after finalization, and finally updated TDMI in the TDMA, (i.e., TDDS # m and TDFL # m fill in the DMA and serve as final DMI) (state 6). With reference to the embodiment in FIG. 7, the finalization flag is set

to "1" to indicate finalization in the TDDS and the TDDS is recorded in the TDMA to indicate the disc is finalized. Also, to prevent the TDMI from being updated in the TDMA, predetermined bits (e.g., "FFh"), may fill in a remaining area of the TDMA where data is not recorded. As a result, the TDMA is filled in.

5 DM-off mode

The life of the write-once optical medium according to the DM-off mode is shown in a lower part of FIG. 1. If it is determined that the disc 1 is to be used according to the DM-off mode, the empty disc 1 is initialized to the DM-off mode. The DMA of the disc initialized to the DM-off mode is empty and the TDMA enters a state 7 where the TDMA can be updated. The TDDS recorded as initial information in the TDMA during disc initialization includes starting location information of the user data area and ending location information of the user data area the size information of the spare area #1 and the size information of the spare area #2 are recorded as "0". Also, the DM mode is set to the DM-off mode.

15 Since defect management is not performed during data recording, the TDDS and the SBM are mainly updated in the TDMA. Since defect management is not performed, detailed data of the TDDS used in the DM-off mode may be different. To differentiate the TDDS and the SBM used in the DM-off mode from those used in the DM-on mode, the TDDS and the SBM used in the DM-off mode are called recording management information.

20 In the DM-off mode, data is recorded in the disc 1 without defect management by a drive device and the TDMA maintains a state 8 where the TDMA can be updated. When the disc 1 is finalized, the finalization flag is set in the TDMA so as to prevent the disc 1 from being used after finalization (state 9). Also, the final TDMI (i.e., recording management information) updated in the TDMA fills in the DMA and serves as final DMI (state 9). The finalized disc 1 has a state where the finalization flag indicating finalization is set in the TDDS or the SBM recorded in the TDMA, the TDDS and the SBM that are finally updated in the TDMA are recorded as DMI in the DMA, and equivalent values to "FFh" are recorded in a remaining area where the SBM can be recorded (i.e., the remaining area of the TDMA) so as to prevent data from being recorded in the remaining area of the TDMA.

30 Hereinafter, a recording/reproducing apparatus that makes it possible to use the

above-described disc will be described with reference to FIG. 11. FIG. 11 is a schematic block diagram of a recording/reproducing apparatus according to the present invention. Referring to FIG. 11, the recording/reproducing apparatus includes a recording/reading unit 21 and a control unit 23. The recording/reading unit 21 includes a pickup to record data on a disc 22, which is an optical recording medium according to an aspect of the present invention and/or, and reads data recorded on the disc 22. The control unit 23 controls the recording/reading unit 21 to record data on and read data from the disc 22 according to an aspect of a predetermined file system. In particular, according to the present invention, the control unit 23 determines whether to perform defect management during data recording when the empty disc 22 is loaded in the recording/reading unit 21 and initializes the disc 22 according to a result of the determination. Also, the control unit 23 controls the recording/reading unit 21 to recode data in the disc 22 according to the result of determination as described below in greater detail.

The control unit 23 includes a host I/F 24, a DSP 25, an RF AMP 26, a servo 27, and a system controller 28. During data recording, the host I/F 24 receives a predetermined recording command from a host 29 and transmits the predetermined recording command to the system controller 28. The system controller 28 controls the DSP 25 and the servo 27 to execute the predetermined recording command received from the host I/F 24. The DSP 25 adds additional data, such as parity to data received from the host I/F 24 for error correction, creates error correction blocks (i.e., ECC blocks) by performing error correction code (ECC) encoding on the data, and modulates the ECC blocks in a predetermined way. The RF AMP 26 converts data output from the DSP 25 into RF signals. The recording/reading unit 21 includes the pickup to record the RF signals transmitted from the RF AMP 26 on the disc 22. The servo 27 receives a command necessary to servo control from the system controller 28 and servo controls the pickup of the recording/reading unit 21.

In particular, according to an aspect of the present invention, the system controller 28 determines whether to use the disc 22 in the DM-on mode or the DM-off mode. Such determination indicates whether defect management is to be performed while data is recorded in the disc 22. While not required in all aspects of the invention, the system controller 28 detects input from a user or detects input from the drive

manufacturer and uses the detected input to determine whether the disc 22 is in the DM-on mode or the DM-off mode. However, it is understood that the input can be otherwise received.

If the system controller 28 determines to use the disc 22 in the DM-on mode, the controller 28 controls the recording/reading unit 21 to perform defect management while data is recorded on the disc 22. In other words, the system controller 28 controls the recording/reading unit 21 to record a replacement block, which replaces a defect block of a user data area of the recording medium where a defect is generated, in a spare area of the recording medium 22 in predetermined operation units to and update information on the defect and TDMI for management of the defect in a TDMA of the recording medium in predetermined operation units. The system controller 28 further changes the size of the spare area while the disc 22 is used in the DM-on mode as needed. The system controller 28 controls the recording/reading unit 21 to record information on the changed size of the spare area (if any) in the TDMA.

Even if the disc 22 is set to the DM-on mode during disc initialization, the system controller 28 can convert the DM mode of the disc 22 into the DM-off mode while the disc 22 is used in the DM-on mode. For such conversion, the system controller 28 reinitializes the disc 22 to the DM-off mode and controls the recording/reading unit 21 to record data in the disc 22 without defect management. In other words, during reinitialization, the system controller 28 controls the recording/reading unit 21 to record information indicating that the disc 22 is used in the DM-off mode in the TDMA and to record TDMI finally updated in the TDMA in the DMA provided in the recording medium 22.

When the disc 22 used in this way is finalized, the system controller 28 controls the recording/reading unit 21 to record the finalization flag indicating that the recording medium 22 is finalized in the TDMA, to record the TDMI finally updated in the TDMA in a disc management area (DMA) provided in the recording medium 22 as the DMI, and to fill with predetermine data a remaining area of the TDMA that is not written to.

When the system controller 28 determines to use the disc 22 in the DM-off mode, it controls the recording/reading unit 21 to record data in the disc 22 without defect management. In other words, the system controller 28 controls the recording/reading unit 21 to record data in the user data area provided in the disc 21 in predetermined

operation units and update recording management information according to such recording in a temporary defect management area provided in the disc 21. Also, in the same way as in the DM-on mode, when the disc 22 is finalized, the system controller 28 controls the recording/reading unit 22 to record the finalization flag, which indicates that the disc 22 is finalized, in the TDMA, record the TDMI finally updated in the TDMA in a disc management area provided in the disc 22, and fill with predetermined data in a remaining area of the TDMA that is not written to.

During reproduction, the host I/F 24 receives a reproduction command from the host 29. The system controller 28 performs initialization necessary to reproduction. The recording/reading unit 21 projects laser beams onto the disc 22 and outputs a light signal obtained by receiving the laser beams reflected off the disc 22. The RF AMP 26 converts the light signal output from the recording/reading unit 21 into an RF signal, provides modulated data obtained from the RF signal to the DSP 25, and provides a servo signal for control, obtained from the RF signal, to the servo 27. The servo 27 receives the servo signal from the RF AMP 26 and a command necessary to servo control from the system controller 28 and performs servo control on the pickup. The host I/F 24 transmits data received from the DSP 25 to the host 29.

In particular, according to an aspect of the present invention, the system controller 28 controls the recording/reading unit 21 to read mode information from the TDMA provided in the disc 22 and read data recorded in the data area based on the read information. When the read mode information is the DM-on mode, the system controller 28 controls the recording/reading unit 21 to read finally updated information on the defect and defect management information from the TDMA, and if the finalization flag, which indicates the recording medium 22 is finalized, is read from the TDMA, the system controller 28 controls the recording/reading unit 28 to read finally updated information on the defect and defect management information from the DMA provided in the disc 22.

When the read mode information is the DM-off mode, the system controller 28 controls the recording/reading unit 21 to read the final recording management information from the TDMA. If the finalization flag, which indicates the recording medium 22 is finalized, is read from the TDMA, the system controller 28 controls the recording/reading unit 21 to read finally updated recording management information

from the DMA provided in the disc 22.

FIGs. 12A through 12E are flowcharts illustrating a method of using the write-once recording medium in the DM-on mode or the DM-off mode, according to an aspect of the present invention.

5 While not required in all aspects, the method in FIGs. 12A through 12E can be implemented as software readable by a computer. Further, it is understood that if the controller 28 is a general or special purpose computer, the method in FIGs. 12A through 12E can be implemented by the controller 28 reading a computer readable medium to retrieve the method encoded on the computer readable medium. Once the
10 write-once recording medium 22 is loaded in a drive system, the system controller 28 of the drive system identifies the loaded disc 22 (i.e., what the type of the loaded disc 22 is) whether the loaded disc 22 is recordable, and whether the loaded disc 22 is already used, using information stored in the loaded disc 22. If the loaded write-once recording medium is identified as an empty disc 22 in operation 10, the system
15 controller 28 performs an initialization process according to a command of a user or the intention of a drive manufacturer.

In operation 15, the system controller 28 determines whether to implement a DM mode according to the intention of a user or a drive manufacturer. When the system controller 28 determines not to perform defect management according to
20 the intention of a user or a drive manufacturer and selects the DM-off mode, initialization information is recorded in the disc 22 in operation 20, and the process goes to A in FIG. 12E. Since defect management is not performed in the DM-off mode and the spare area is not assigned, the size information of the spare area is recorded as "0" in the TDDS recorded in the TDMA and the DM mode is set to the
25 DM-off mode.

When the system controller 28 selects the DM-on mode, it assigns the spare area to a portion of the data area of the disc 22 and records information necessary to defect management by a drive device and the initialization information in the disc (operation 30). More specifically, initialization is included in TDDS #0, SBM #0, and
30 TDFL #0 and then recorded in the TDMA. With reference to the embodiment as shown in FIG. 7, TDDS #0 includes the size and location information of the spare area provided in the data area, the starting location information and ending location

information of the user data area, the TDFL pointer, and the DM mode set to the DM-on mode. Once the disc 22 is initialized, the DMA of the disc 22 is empty and the TDMA enters a state where the TDMA can be updated.

After initialization, the recording/reading unit 21 and the control unit 23 performs
5 recording through a verify-after-write procedure for defect management in response to a recording command of a host (operation 40). Hereinafter, the verify-after-write procedure of operation 40 will be described in greater detail with reference to FIG. 12B.

In operation 41, user data is recorded in the user data area in units that the
10 verify-after-write procedure is performed. In operation 42, recorded data is verified to find a portion where a defect is generated and a replacement block that replaces a defect block is recorded in the spare area. In operation 43, information on the defect is created and stored in the memory. In operation 44, it is determined whether a predetermined recording operation is completed. If the predetermined recording operation is not completed, a process goes to operation 41 and recording is repeated.
15 If the predetermined recording operation is completed, the process goes to operation 50 shown in FIG. 12A and in greater detail in FIG. 12C.

In operation 50, defect information and defect management information are updated in operation units. The update procedure of operation 50 will be described in
20 detail with reference to FIG. 12C. In operation 51, information on the defect, stored in the memory, is read in. In operation 52, a defect list including the information on the defect is created. In operation 53, the created defect list is recorded as TDFL # i in the TDMA, where i corresponds to a number of the recording operation. In operation 54, TDDS # i and SBM # i are recorded in the TDMA. Detailed examples of such operation 40 of performing recording through the verify-after-write procedure and
25 operation 50 of updating the defect information and defect management information will be described with reference to FIG. 13.

FIG. 13 is a reference view for explaining a process of defect management according to an aspect of the present invention. Here, a data processing unit can be divided into a sector and a cluster. The sector is a minimum data unit that can be
30 managed by a file system of a computer or an application program. The cluster is a minimum data unit that can be physically recorded in a disc at a time. In general, at least one sector constitutes one cluster.

The sector comprises a physical sector and a logical sector. The physical sector is a space of a disc where data corresponding to one sector is recorded. An address used to find the physical sector is called a physical sector number (PSN). The logic sector is a sector unit used to manage data in the file system or the application program. Likewise, a logical sector number (LSN) is assigned to the logical sector. A data recording and/or reproducing apparatus such as that shown in FIG. 11, which records data to and reads data from the disc, finds the location of data to be recorded or reproduced on the disc using the PSN, whereas a computer or an application program for recording or reproducing data manages the entire data in units of logical sectors and finds the location of the data using the LSN. The relationship between the LSN and the PSN is converted using a fact of whether or not a defect is generated and a location where data recording starts.

Referring to FIG. 13, a user data area and a spare area are shown. In the user data area and the spare area, there is a plurality of physical sectors (not shown) to which PSNs are sequentially assigned. LSNs are assigned to at least one physical sector unit. However, the LSNs are assigned to replacement areas of the spare area except for defect areas of the user data area where defects are generated. As a result, although the physical sector and the logical sector are the same in size, if the defect areas are generated, the PSNs and the LSNs become different.

The user data is recorded in the user data area according to a sequential recording mode or a random recording mode. In the sequential recording mode, the user data is sequentially and continuously recorded. In the random recording mode, the user data is not necessarily continuously recorded, but is recorded at random. (1) through (7) indicate unit areas in which verify-after-write procedure is performed. The data recording and/or reproducing apparatus records the user data in the unit area (1), the data recording and/or reproducing apparatus returns to start of the unit area (1) and verifies if the user data is recorded normally or a defect is generated. If a cluster where a defect is generated is found, the cluster is identified as a defect cluster and is designated as a defect area (i.e., a defect #1). Also, the data recording and/or reproducing apparatus rewrites the user data, which has been recorded in the defect #1, in the spare area. A part of the spare area where the user data is rewritten is designated as a replacement #1. Next, after recording the user data in the unit area

(2), the data recording and/or reproducing apparatus returns to start of the unit area (2) and verifies if the user data is recorded normally or a defect is generated. If at least one cluster where a defect is generated is found, such a cluster is designated as a defect #2. In the same manner as the above, a replacement #2 corresponding to the defect #2 is designated. Also, in the unit area (3), a defect area (i.e., a defect #3), and a replacement #3 corresponding to the defect #3 are designated. In the unit area (4), a part where a defect is generated is not found and there is no defect area.

After recording and verification are completed to the unit area (4), if termination of a recording operation #1 is expected (for example, if a user pushes an eject button or recording of the user data assigned to the recording operation #1 is completed), the data recording and/or reproducing apparatus records in the TDFL temporary defect information (i.e., TDFL #1) location information of the defects #1 through #3 that are generated in the unit areas (1) through (4). Also, management information for management of TDFL #1 is recorded as TDDS #1 in the TDMA.

Once the recording operation #1 starts, data is recorded in (5) through (7) the same way as in the unit areas (1) through (4). Thus, defects #4 and #5 and replacements #4 and #5 corresponding thereto are designated. The defects #1, #2, #3, and #4 are single defect blocks, each of which includes a defect. The defect #5 is a consecutive defect block whose consecutive blocks include defects. The replacement #5 is a consecutive replacement block that replaces the defect #5. A block is a physical or logical recording unit and may vary. If completion of the recording operation #1 is expected, the recording apparatus records temporary defect information #2 (i.e., TDFL #2), including information on the defects #4 and #5 and further records information recorded in the temporary defect information #1 accumulatively. Likewise, defect management information for management of TDFL #2 is recorded as TDDS #2 in the TDMA.

Referring back to FIG. 12A, the system controller 28 determines whether to change the size of the spare area in operation 60 when the spare area is not enough and needs to be enlarged or the user data area is not enough and the spare area needs to be reduced. If the system controller 28 determines to change the size of the spare area, reinitialization information is recorded in the disc 22 in operation 70 and the process goes to operation 40. In other words, the changed size information of the

spare area is included in the TDDS and the TDDS is recorded in the TDMA.

Next, the system controller 28 determines whether to reinitialize the disc 22 to the DM-off mode (operation 80). If the system controller 28 determines to reinitialize the disc 22, the reinitialize information is recorded in the disc 22 in operation 81 and the process goes to A shown in FIG. 12E. If the disc 22 is reinitialized to the DM-off mode, the DM-on mode set in the TDDS is converted into the DM-off mode to update the TDDS and the TDDS and the TDFL finally updated in the TDMA are recorded in the DMA for compatibility with rewritable media.

Next, the system controller 28 determines whether to finalize the disc 22 (operation 90). If the system controller 28 determines not to finalize the disc 22, the process goes to operation 40 and recording is performed through the verify-after-write procedure. If the system controller 28 determines to finalize the disc, the system controller 28 records finalization information in the disc (operation 100).

Recording of the finalization information in the disc of operation 100 will be described in detail with reference to FIG. 12D. The system controller 28 sets the finalization flag to "1" in the TDDS or the SBM in operation 101 and records specific values in the entire remaining area of the SBM that is not written to in operation 102. According to shown embodiments, the specific values may be recorded in the entire remaining area of the TDMA that is not written to. In operation 103, the finally updated TDDS and TDFL recorded in the TDMA fill in the DMA.

Next, operations when the DM-off mode is selected will be described with reference to FIG. 12E. In operation 110, the system controller 28 controls the recording/reading unit 21 to record data in the disc 22 without defect management. In operation 120, the system controller 28 updates the TDMA. Since defect management is not performed, updates in the TDMA are mainly to the TDDS and SBM.

In operation 130, the system controller 28 determines whether to finalize the disc 22.

If the system controller 28 determines to finalize the disc 22, finalization information is recorded in the DMA (operation 140). The recording of the finalization information in operation 140 is the same as the description set forth above with reference to FIG. 12D and is not again set forth. If the system controller 28 determines not to finalize the disc 22, the process goes to operation 110 and recording is performed without defect management.

As described above, according to aspects of the present invention, a recording medium can be selectively used while defect management is performed on the recording medium or not performed according to the selection. Also, it is possible to use the recording medium without defect management even after using the recording medium while defect management is performed on the recording medium. Additionally, the recording medium can be used compatibly with rewritable media. Moreover, the recording medium can be CD-R, DVD-R, Bluray discs, Advanced Optical Discs (AODs), rewritable media, magnetic media and/or magneto-optical media which perform defect management.

The recording/reproducing method can be implemented as computer readable codes in computer readable recording media. The computer readable recording media include all kinds of recording apparatuses in which data that can be read by a computer system is stored. Such computer readable recording media are ROM, RAM, CD-ROM, magnetic tape, floppy disk, and optical data storage, and transmissions via the Internet (e.g., carrier wave). The computer readable recording media can be distributed in a computer system connected to a network, and can be stored and operated in forms of computer readable codes. Functional programs, codes, and code segments for implementing the recording/reproducing method can be easily construed by programmers skilled in the art.

While embodiments of the present invention has been particularly shown and described with reference to exemplary embodiments thereof, it will be understood by those of ordinary skill in the art that various changes in form and details may be made therein without departing from the spirit and scope of the present invention as defined by the following claims and equivalents thereof.

What is claimed is:

1. A method of recording data on a recording medium, the method comprising:

5 selecting a defect management mode selectable between a defect management on mode and a defect management off mode so that the selected mode indicates whether defect management is to be performed on the recording medium;

recording the data on the recording medium while defect management is performed on the recording medium, if the defect management on-mode is selected; and

10 recording the data on the recording medium without defect management, if the defect management off mode is selected.

2. The method of claim 1, wherein recording of the data in the defect management on mode comprises initializing the recording medium to the defect management on mode, wherein the initialization comprises:

15 assigning a spare area to a data area of the recording medium for replacing a defect generated in the data area of the recording medium; and

recording temporary defect management information including information on the assigned spare area and an identifier indicating the defect management on mode, in a temporary defect management area of the recording medium.

3. The method of claim 2, wherein the recording of the data in the defect management on mode further comprises:

25 recording a replacement block, which replaces a defect block concerning the defect generated in the data area, in the spare area in predetermined operation units; and

updating the information on the defect and the defect management information for defect management as the temporary defect management information in the temporary defect management area in predetermined operation units.

30

4. The method of claim 3, wherein the recording of the data in the defect management on mode further comprises:

changing a size of the spare area; and

updating the temporary defect management information to include information on the changed size of the spare area and recording the updated temporary defect management information in the temporary defect management area.

5

5. The method of claim 3, wherein the recording of the data in the defect management on mode further comprises converting the defect management on mode into the defect management off mode.

10 6. The method of claim 5, wherein the conversion into the defect management off mode comprises:

reinitializing the recording medium to be in the defect management off mode;
and

15 recording the data on the recording medium without defect management after the recording medium is reinitialized in the defect management off mode.

7. The method of claim 6, wherein the reinitialization to the defect management off mode comprises:

20 recording an identifier indicating the defect management off mode in the temporary defect management area; and

recording the temporary defect management information that was finally updated in the temporary defect management area in a defect management area of the recording medium.

25 8. The method of claim 3, further comprising finalizing the recording medium.

9. The method of claim 8, wherein the finalization of the recording medium comprises:

30 recording a finalization flag indicating the finalization of the recording medium in the temporary defect management area;

recording temporary defect management information including recording finally

updated information on the defect and defect management information of the temporary defect management area in a defect management area of the recording medium; and

5 filling with predetermined data a remaining area of the temporary defect management area where no data is recorded.

10. The method of claim 1, wherein recording of the data in the defect management off mode comprises:

10 recording the data in a data area of the recording medium in predetermined operation units; and

updating recording management information according to the recording of the data in a temporary defect management area of the recording medium.

15 11. The method of claim 10, further comprising finalizing the recording medium.

12. The method of claim 11, wherein the finalization of the recording medium comprises:

20 recording a finalization flag, which indicates the recording medium is finalized, in the temporary defect management area;

recording recording management information that is finally updated in the temporary defect management area in a defect management area of the recording medium; and

25 filling with predetermined data a remaining area of the temporary defect management area where no data is recorded.

13. A method of reproducing data recorded on a recording medium having a lead-in area, a data area, and a lead-out area consecutively arranged, the method comprising:

30 reading defect management on/off mode information, which indicate whether defect management is performed on the recording medium, from a temporary defect management area in the lead-in area or the lead-out area, and which is used to update

information on a defect generated in the data area and defect management information for management of the defect for every predetermined operations; and

reading data recorded in the data area based on the read defect management on/off mode information.

5

14. The method of claim 13, further comprising reading finally updated information on the defect and finally updated defect management information from the temporary defect management area, if the read defect management on/off mode information is a defect management on mode.

10

15. The method of claim 14, further comprising:

reading a finalization flag, which indicates the recording medium is finalized, from the temporary defect management area; and

15 reading the finally updated information on the defect and the finally updated defect management information from a defect management area of the recording medium.

16. The method of claim 13, further comprising reading final recording management information from the temporary defect management area, if the read defect management on/off mode information is a defect management off mode.

20

17. The method of claim 16, further comprising:

reading the finalization flag, which indicates the recording medium is finalized, from the temporary defect management area; and

25 reading the finally updated information on the defect and the finally updated defect management information from a defect management area of the recording medium.

18. An apparatus for recording and/or reproducing data with respect to a recording medium, the apparatus comprising:

30

a recording/reading unit, which transfers the data with respect to the recording medium; and

a control unit, which selects a defect management mode selectable between a defect management on mode and a defect management off mode so that the selected defect management mode indicates whether defect management is to be performed while data is recorded in the recording medium, controls the recording/reading unit to record the data in the recording medium while defect management is performed on the recording medium, if the defect management on mode is selected, and controls the recording/reading unit to record the data in the recording medium without defect management, if the defect management off mode is selected.

19. The apparatus of claim 18, wherein the control unit initializes the recording medium to the defect management on mode when the defect management on mode is selected, and during the initialization, the control unit assigns a spare area for replacing a defect generated in a data area of the recording medium to the data area and controls the recording/reading unit to record information on the assigned spare area and temporary defect management information, which includes an identifier indicating the defect management on mode, in a temporary defect management area of the recording medium.

20. The apparatus of claim 19, wherein the control unit further controls the recording/reading unit to record a replacement block, which replaces a defect block having the defect generated in the data area, in the spare area in each of predetermined operation units, and to update the information on the defect and the defect management information for defect management as the temporary defect management information in the temporary defect management area in the predetermined operation units.

21. The apparatus of claim 20, wherein the control unit further changes a size of the spare area and controls the recording/reading unit to update the temporary defect management information to include information on the changed size of the spare area and to record the updated temporary defect management information in the temporary defect management area.

22. The apparatus of claim 20, wherein the control unit further converts the defect management on mode into the defect management off mode.

23. The apparatus of claim 22, wherein the control unit reinitializes the recording medium to the defect management off mode and controls the recording/reading unit to record the data in the recording medium without defect management after the conversion to the defect management off mode.

24. The apparatus of claim 23, wherein the control unit further controls the recording/reading unit to record an identifier indicating the defect management off mode in the temporary defect management area and to record temporary defect management information that was finally updated in the temporary defect management area in a defect management area of the recording medium.

25. The apparatus of claim 20, wherein the control unit controls the recording/reading unit to record a finalization flag indicating a finalization of the recording medium in the temporary defect management area, to record the temporary defect management information including the finally updated information on the defect and defect management information of the temporary defect management area in a disc management area of the recording medium, and to fill with predetermined data a remaining area of the temporary defect management area where no data was recorded.

26. The apparatus of claim 18, wherein:
the control unit controls the recording/reading unit to record the data in a data area of the recording medium in predetermined operation units, and to update recording management information according to the recording of the data in a temporary defect management area of the recording medium when the defect management off mode is selected, and

the recording management information does not include defect management information.

27. The apparatus of claim 26, wherein the control unit controls the recording/reading unit to:

record a finalization flag, which indicates the recording medium is finalized, in the temporary defect management area,

5 record recording management information finally updated in the temporary defect management area in a disc management area provided in the recording medium, and

fill with predetermined data in a remaining area of the temporary defect management area where no data was recorded.

10

28. An apparatus for recording and/or reproducing data recorded on a recording medium where a lead-in area, a data area, and a lead-out area are consecutively arranged, the apparatus comprising:

a reading unit, which transfers data with respect to the recording medium; and

15 a control unit, which controls the reading unit to read defect management on/off mode information, where the mode selectively indicates one of whether defect management has been performed on the recording medium and whether defect management has not been performed, from a temporary defect management area provided in the lead-in area or the lead-out area so as to update information on a
20 defect generated in the data area and defect management information used for management of a defect for each of a plurality of predetermined operations, and controls the reading unit to read data recorded in the data area based on the read defect management on/off mode information.

25 29. The apparatus of claim 28, wherein the control unit further controls the reading unit to read finally updated information on the defect and finally updated defect management information from the temporary defect management area, if the read defect management on/off mode information is a defect management on mode.

30 30. The apparatus of claim 29, wherein the control unit controls the reading unit to read a finalization flag, which indicates the recording medium was finalized, from the temporary defect management area, and to read the finally updated information on

the defect and the finally updated defect management information from a defect management area of the recording medium.

31. The apparatus of claim 28, wherein the control unit controls the reading unit to read final recording management information from the temporary defect management area, if the read defect management on/off mode information is a defect management off mode.

32. The apparatus of claim 31, wherein the control unit controls the reading unit to read a finalization flag, which indicates the recording medium was finalized, from the temporary defect management area, and to read the finally updated information on the defect and the finally updated defect management information from a defect management area of the recording medium.

33. An optical recording medium for use with a recording and/or reproducing apparatus, comprising:

a lead-in area, a data area, and a lead-out area consecutively arranged in the optical recording medium;

a temporary defect management area for recording temporary information on a defect generated in the data area and temporary defect management information for management of the defect, the temporary defect management area being in the lead in area or lead out area; and

a defect management area for recording final information on the defect and final defect management information and which is in

the lead-in area or the lead-out area,

wherein the temporary defect management information in the temporary defect management area includes defect management on/off mode information that indicates to the apparatus one of whether data is to be recorded on the recording medium while defect management is performed on the recording medium and whether data is to be recorded without defect management.

34. The optical recording medium of claim 33, wherein, if the defect

management on/off mode information indicates to the apparatus that the recording medium is initialized to a defect management on mode:

the medium further comprises a spare area for recording a replacement block that replaces a defect block concerning a defect generated by the apparatus in the data area of the recording medium in predetermined operation units is assigned by the apparatus to the data area,

the defect management area is empty, and

the temporary defect management area enters a state where the information on the defect and the defect management information for management of the defect is updated by the apparatus in predetermined operation units.

35. The optical recording medium of claim 34, wherein, if a size of the spare area of the recording medium is changed by the apparatus and the recording medium is reinitialized, information on a changed size of the spare area is recorded by the apparatus in the temporary defect management area.

36. The optical recording medium of claim 34, wherein, if the defect management on/off mode information indicates to the apparatus that the recording medium is reinitialized to a defect management off mode, information indicating the defect management off mode is recorded by the apparatus in the temporary defect management area and the temporary defect management information that was finally updated in the temporary defect management area is recorded by the apparatus in the defect management area.

37. The optical recording medium of claim 34, wherein, when the recording medium is finalized, a finalization flag, which indicates the recording medium is finalized, is recorded in the temporary defect management area, temporary defect management information finally recorded in the temporary defect management area is recorded in the defect management area, and predetermined data fills in a remaining area of the temporary defect management area where no data was recorded.

38. The optical recording medium of claim 33, wherein, if the defect

management on/off mode information indicates to the apparatus that the recording medium is initialized to the defect management off mode, the defect management area is empty and the temporary defect management area enters a state where recording management information according to the recording of the data in the data area is updated by the apparatus in predetermined operation units.

39. A computer readable recording medium encoded with processing instructions for implementing a method of recording data on a recording medium performed by a computer, the method comprising:

10 selecting a defect management mode as one of a defect management on mode and a defect management off mode so as to indicate whether defect management is to be performed on the recording medium;

recording the data in the recording medium while defect management is performed on the recording medium, if the defect management on mode is selected; and

15 recording the data in the recording medium without defect management, if the defect management off mode is selected.

40. A computer readable recording medium encoded with processing instructions for implementing a method of reproducing data recorded on a recording medium having a lead-in area, a data area, and a lead-out area consecutively arranged as performed by a computer, the method comprising:

20 reading defect management on/off mode information, where the mode indicates whether defect management has been performed on the recording medium and whether defect management was not performed, from a temporary defect management area provided in the lead-in area or the lead-out area, so as to update information on a defect generated in the data area and defect management information for management of the defect for every predetermined operations; and

25 reading data recorded in the data area based on the read defect management on/off mode information.

41. A method of recording data on a recording medium, the method

comprising:

detecting information for a defect management mode selectable between a defect management on mode, in which defect management is performed to manage defects on the recording medium, and a defect management off mode, in which defect management is not performed to manage defects on the recording medium; and

transferring the data with respect to the recording medium according to the selected defect management mode.

42. The method of claim 41, wherein the detecting the information comprises receiving information through an input device to determine the selected defect management mode.

43. The method of claim 41, wherein the detecting the information comprises receiving information from an apparatus which is to perform the transfer to determine the selected defect management mode.

44. The method of claim 43, wherein the transferring the data comprises recording the data, and the method further comprises, if the detected information is the defect management on mode, recording the data using the defect management to manage the defects occurring during the recording the data.

45. The method of claim 41, wherein the transferring the data comprises recording the data, and the method further comprises, if the detected information is the defect management off mode, recording the data without the defect management to manage the defects occurring during the recording the data.

46. The method of claim 41, wherein:

the transferring the data comprises recording the data according to the selected defect management mode,

the selected defect management mode is one of the defect management on mode and the defect management off mode, and

the method further comprises, after the recording the data,

detecting another defect management mode which selects the other one of the defect management on mode and the defect management off mode, and

transferring additional data according to the detected another defect management mode.

5

47. The method of claim 46, wherein:

the recording medium includes a temporary defect management area in which the temporary defect information and temporary defect management information for managing the defects prior to finalization of the recording medium, and a final defect management area which includes the temporary defect information and the temporary defect management information recorded during finalization of the recording medium, and

the method further comprises, after the recording the data and if the detected another defect management mode is the defect management off mode,

recording the temporary defect information and the temporary defect management information for the recorded data in the final defect management area prior to finalization of the recording medium, and

recording fill data in areas of the final defect management area other than the area in which the temporary defect information and the temporary defect management information are recorded.

20

48. An apparatus for recording and/or reproducing data with respect to a recording medium, the apparatus comprising:

a transfer unit that transfers the data with respect to the recording medium; and

a control unit that detects a defect management mode selectable between a defect management on mode, in which defect management is performed to manage defects on the recording medium, and a defect management off mode, in which defect management is not performed to manage defects on the recording medium, and controls the data transfer unit to transfer the data according to the selected defect management mode.

30

49. The apparatus of claim 48, further comprising an input unit through which

the control unit receives information to detect the selected defect management mode.

50. The apparatus of claim 48, wherein, in order to detect the information to determine the selected defect management mode, the control unit retrieves predetermine information stored in the apparatus and which indicates the defect management mode to be selected.

51. The apparatus of claim 48, wherein the control unit controls the transfer unit to, if the defect management mode is the defect management on mode, record the data using the defect management to manage the defects occurring during the recording the data.

52. The apparatus of claim 48, wherein the control unit controls the transfer unit to, if the detected defect management mode is the defect management off mode, record the data without the defect management to manage the defects occurring during the recording the data.

53. The apparatus of claim 48, wherein:
the control unit controls the transfer unit to record the data according to the detected defect management mode, where the detected defect management mode is one of the defect management on mode and the defect management off mode,
the control unit detects another defect management mode which selects the other one of the defect management on mode and the defect management off mode, and
the control unit controls the transfer unit to transfer additional data according to the detected another defect management mode.

54. The apparatus of claim 53, wherein:
the recording medium includes a temporary defect management area in which the temporary defect information and temporary defect management information for managing the defects prior to finalization of the recording medium, and a final defect management area which includes the temporary defect information and the temporary

defect management information recorded during finalization of the recording medium,
and

the control unit further, after the recording the data and if the detected another
defect management mode is the defect management off mode, controls the transfer
unit to record the temporary defect information and the temporary defect management
5 information for the recorded data in the final defect management area prior to
finalization of the recording medium, and record fill data in areas of the final defect
management area other than the area in which the temporary defect information and
the temporary defect management information are recorded.

10

55. A recording medium for use with a recording and/or reproducing
apparatus. comprising:

a data area with respect to which data is to be recorded on the recording
medium, and

15

a defect management area including defect mode information selectable
between a defect management on mode, in which defect management is performed to
manage defects on the recording medium, and a defect management off mode, in
which defect management is not performed to manage defects on the recording
medium,

20

wherein the apparatus transfers the data to the data area according to the one
of the defect management on and off modes selected in the defect mode information.

56. The recording medium of claim 55, wherein:

the defect management area further comprises:

25

a temporary defect management area for recording temporary defect information
on defects generated in the data area and temporary defect management information
for management of the defects; and

a final defect management area for recording final defect information on the
defect and final temporary defect management information, and

30

the temporary defect management information recorded in the temporary defect
management area includes the defect mode information.

57. The recording medium of claim 56, wherein:
the temporary defect management area further comprises finalization information which indicates whether the recording medium has been finalized, and
if the finalization information indicates to the apparatus that the recording
5 medium has not been finalized and the defect mode information indicates to the apparatus the selection of the defect management off mode, the final defect management area is filled in to prevent the apparatus from writing the final defect information and the final management information in the final defect management area.

10 58. The recording medium of claim 56, wherein, if the finalization information indicates to the apparatus that the recording medium has not been finalized and the defect mode information indicates to the apparatus the selection to the defect management off mode, the final defect management area includes a last recorded temporary defect information and a last recorded temporary defect management
15 information which was recorded in the temporary defect management area prior to the selection of the defect management off mode.

59. The recording medium of claim 56, wherein, if the finalization information
indicates to the apparatus that the recording medium has not been finalized and the
20 defect mode information indicates to the apparatus the selection to the defect management off mode, the final defect management area includes no temporary defect information and no temporary defect management information.

FIG. 1

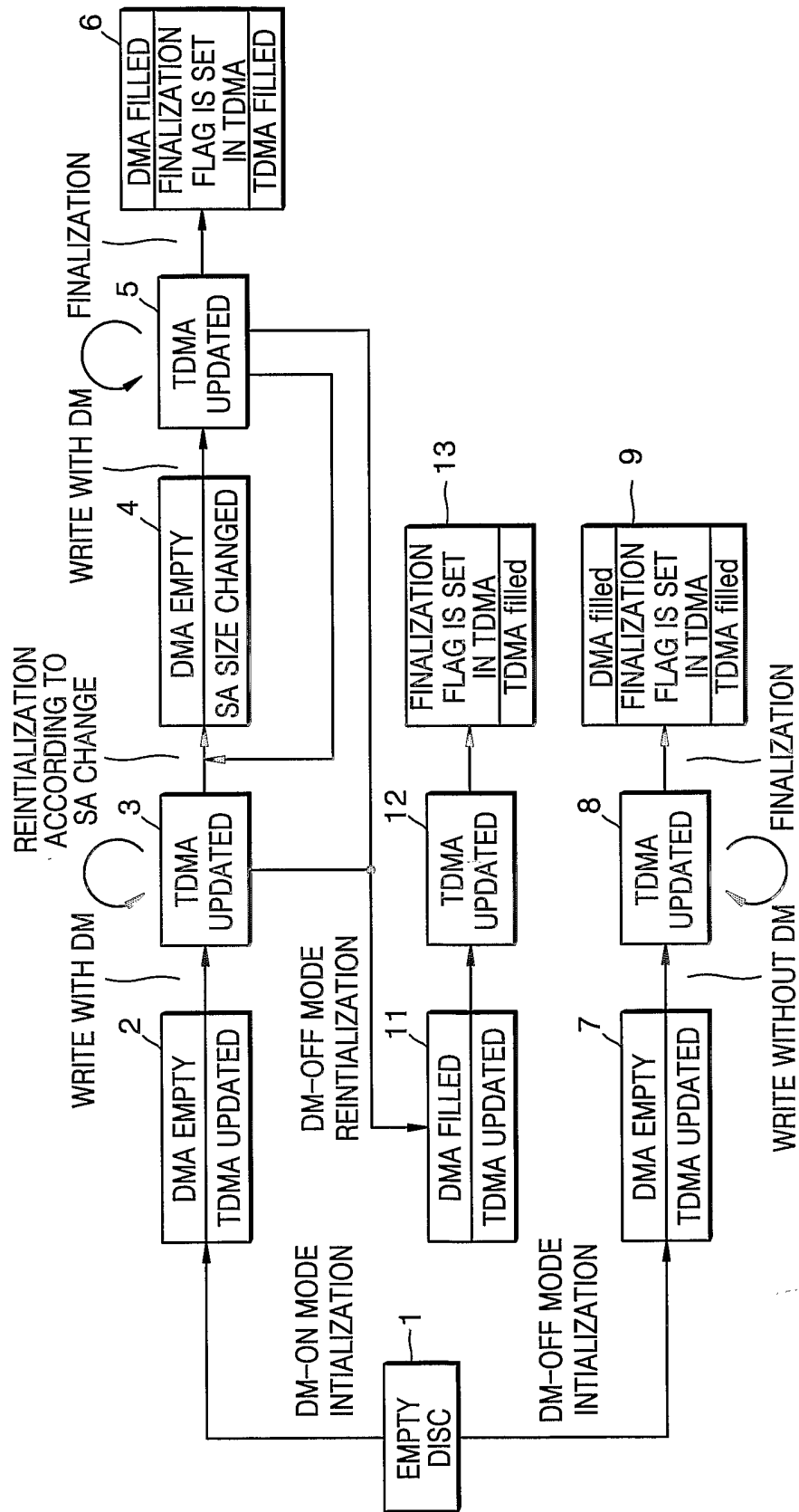

FIG. 2

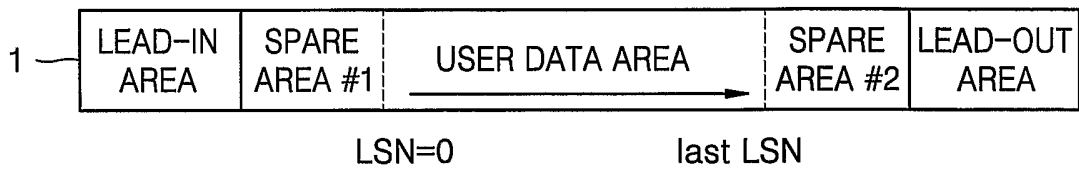

FIG. 3

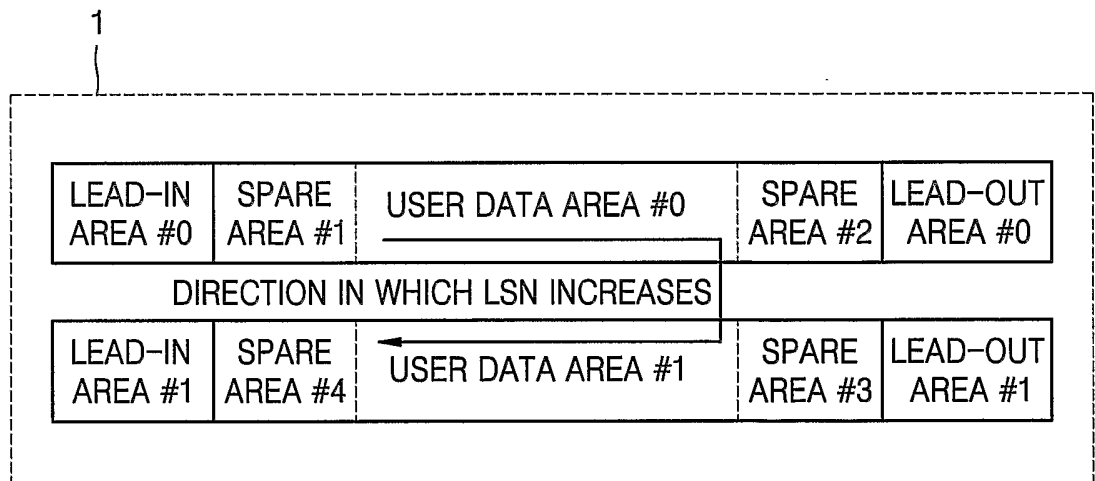

FIG. 4

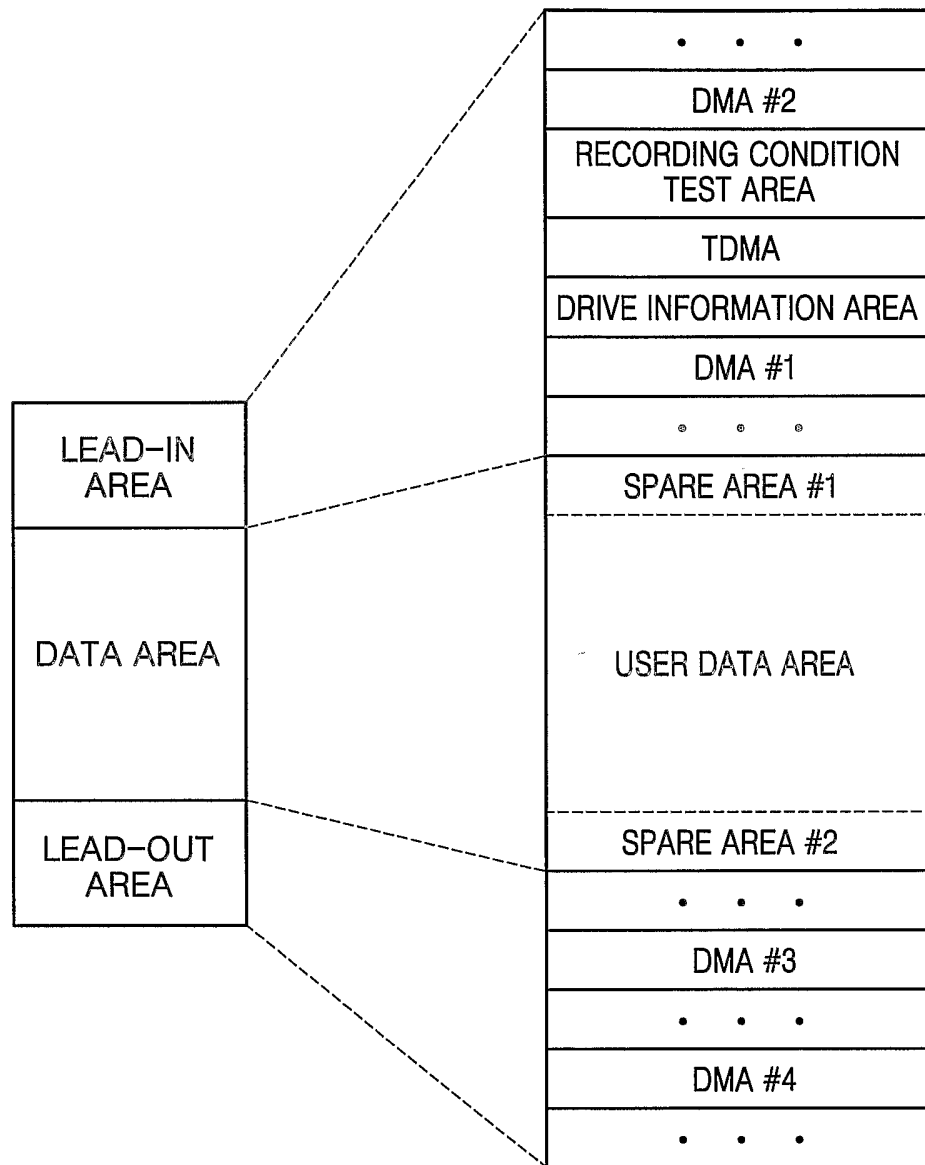

FIG. 5

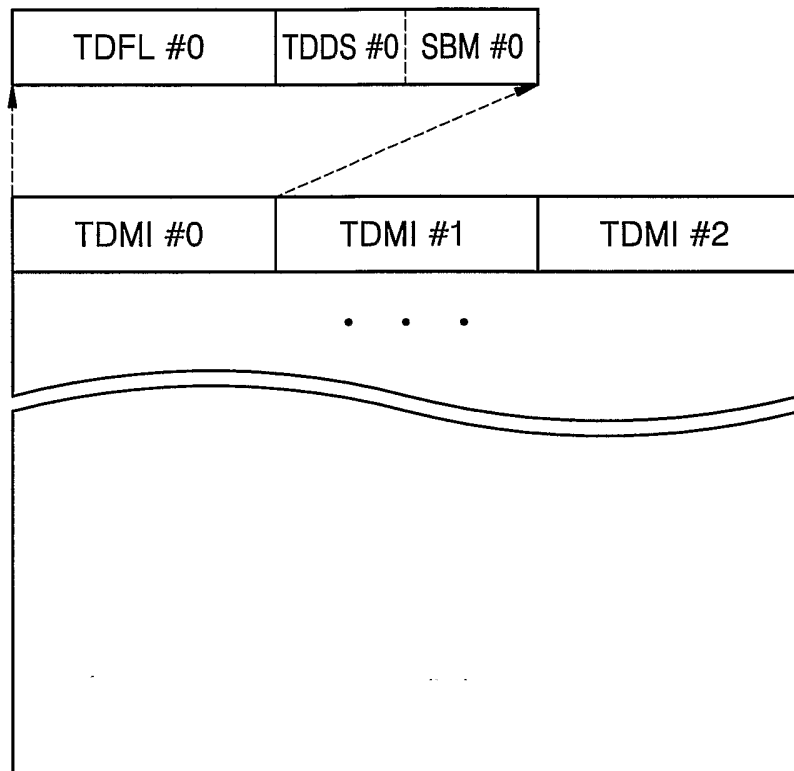

FIG. 6

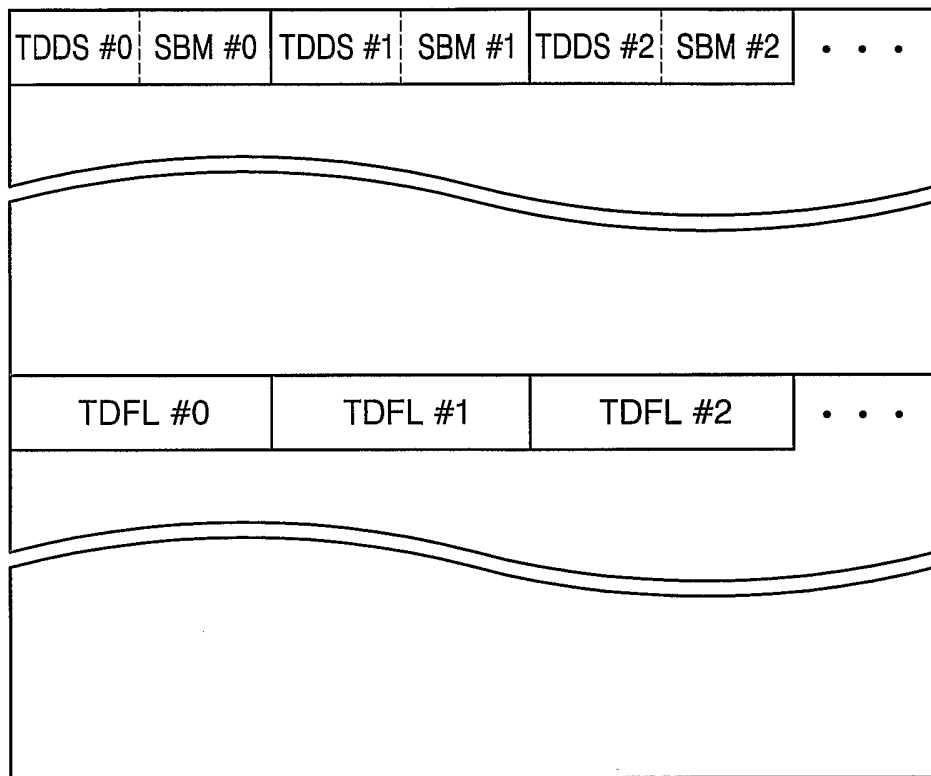

FIG. 7

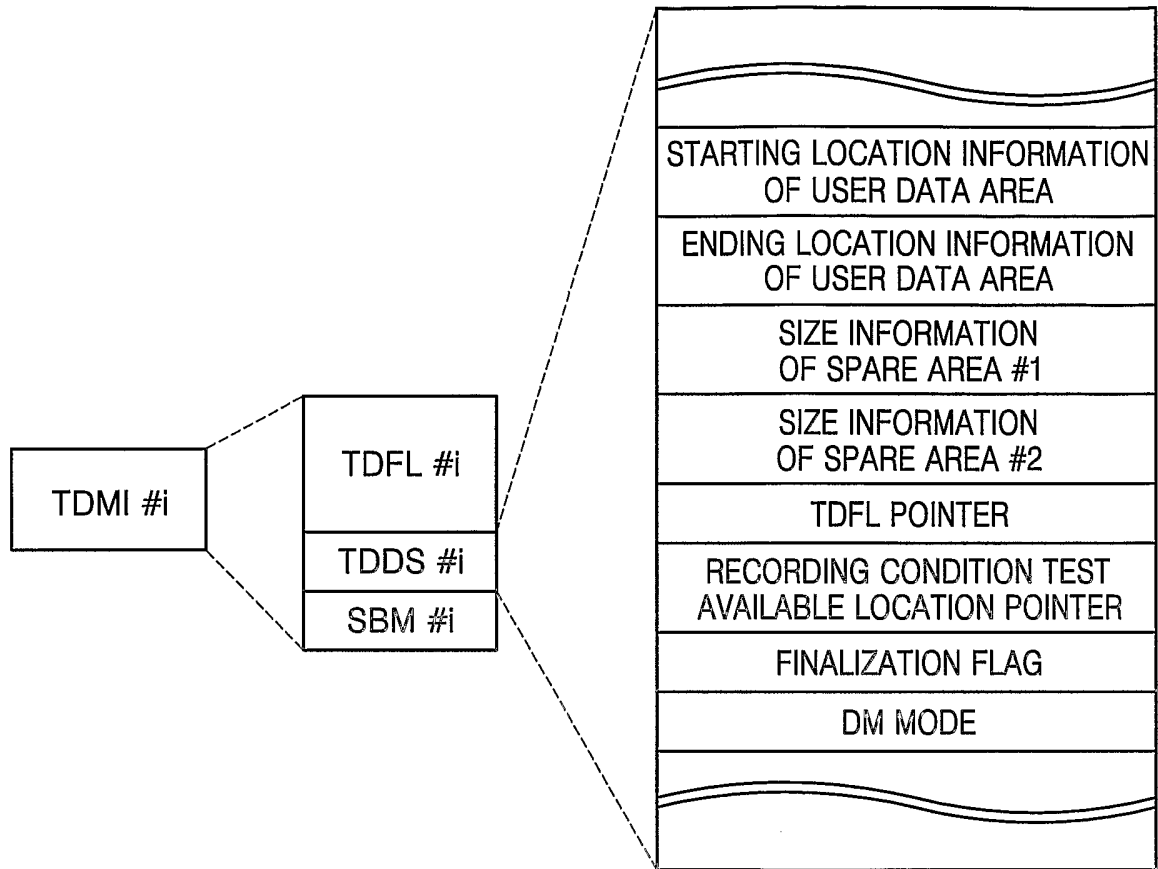

FIG. 8

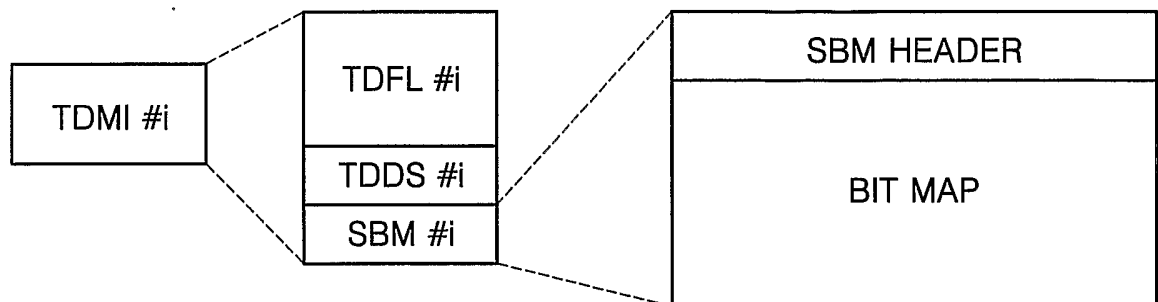

FIG. 9

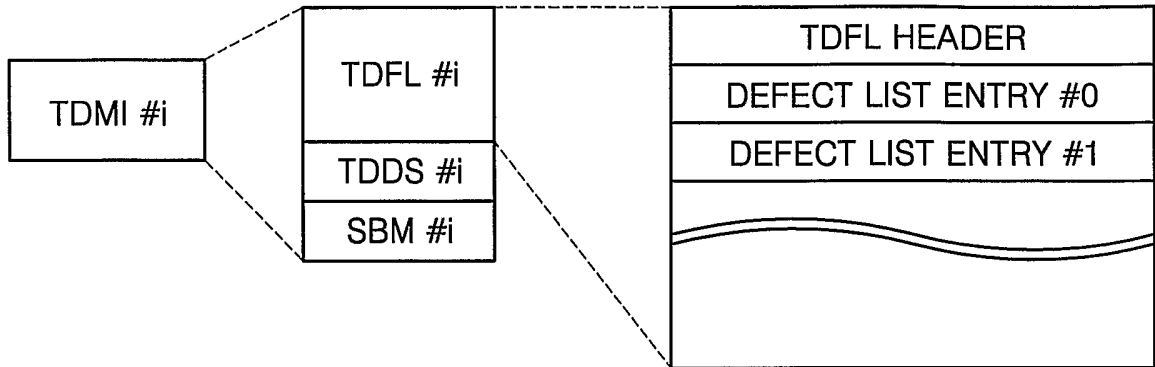

FIG. 10

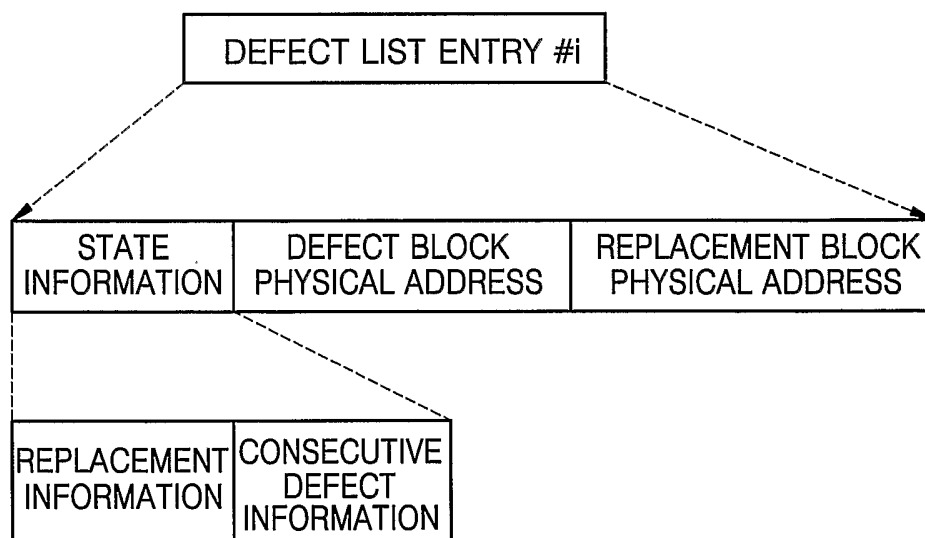

FIG. 11

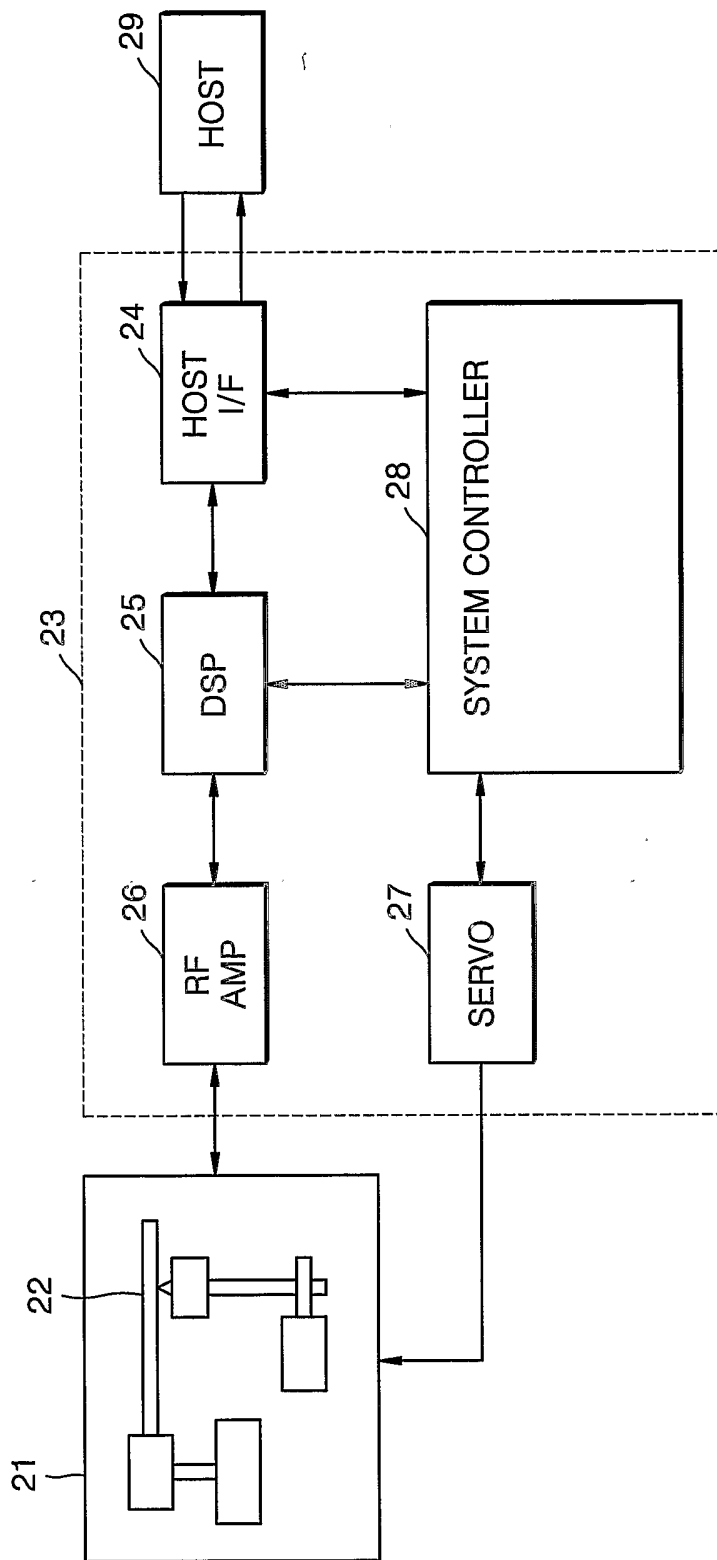

FIG. 12A

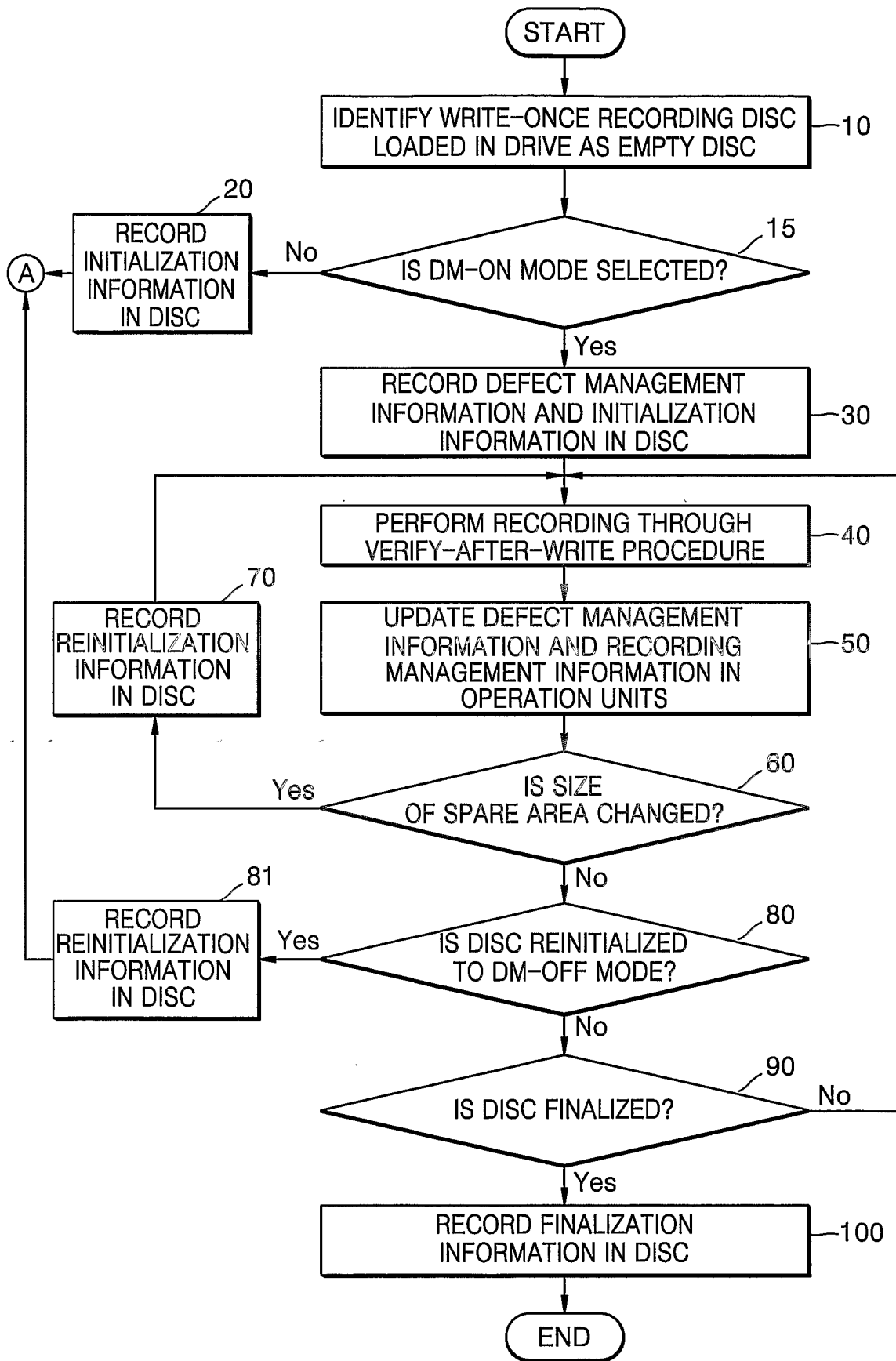
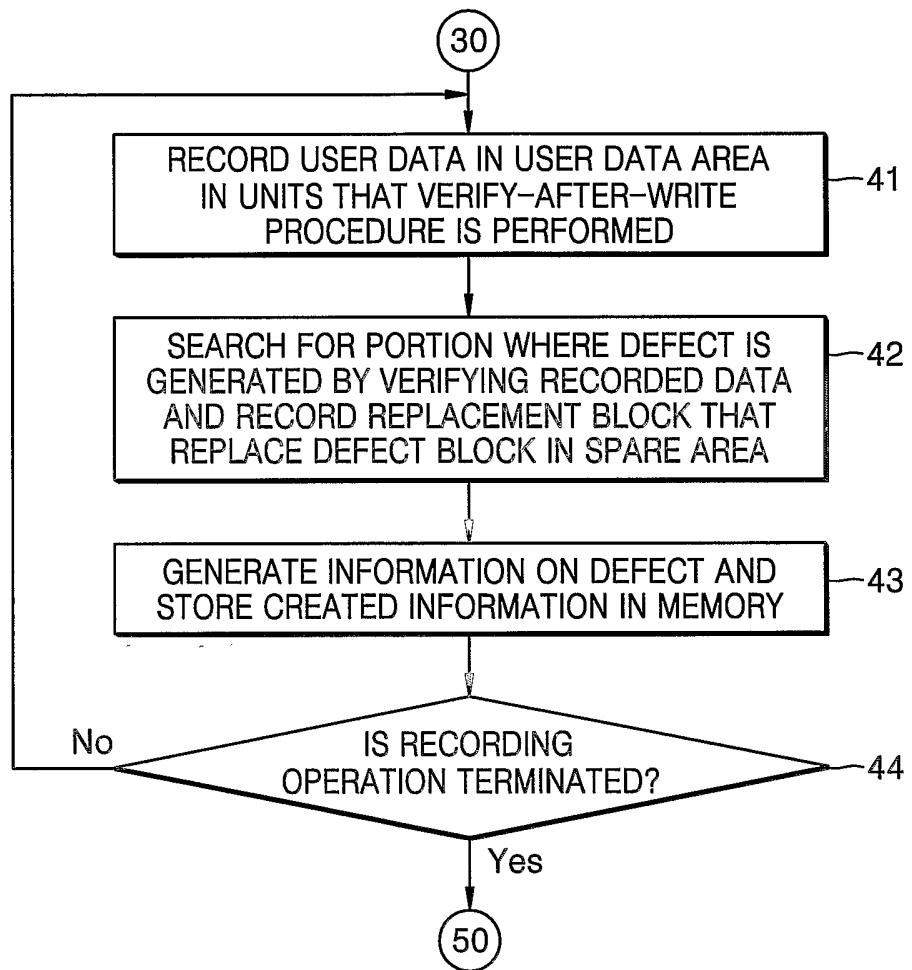

FIG. 12B



11/13

FIG. 12C

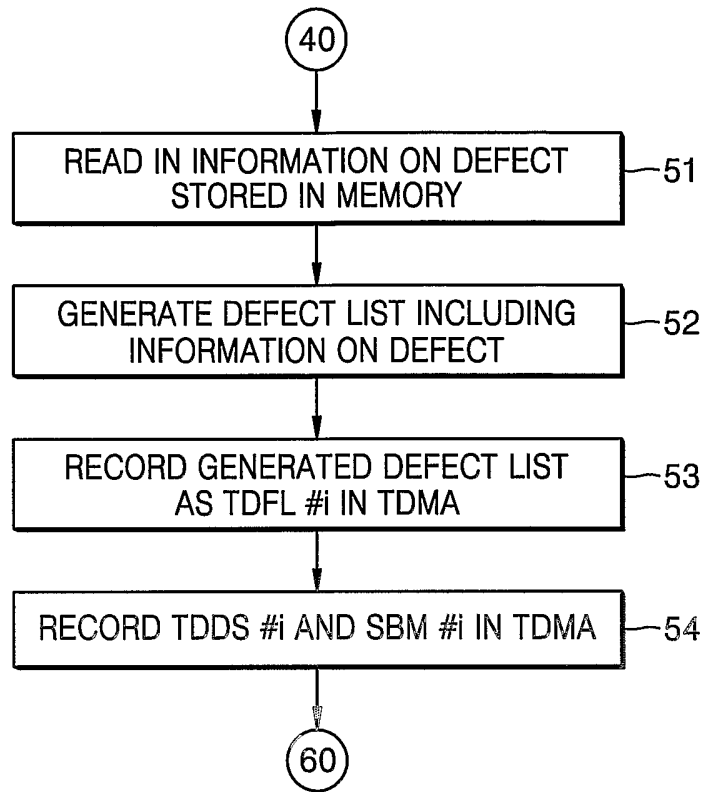
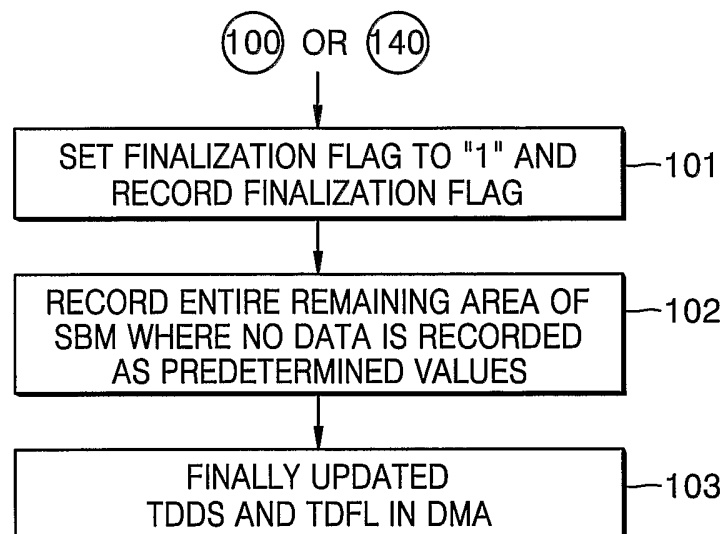

FIG. 12D



12/13

FIG. 12E

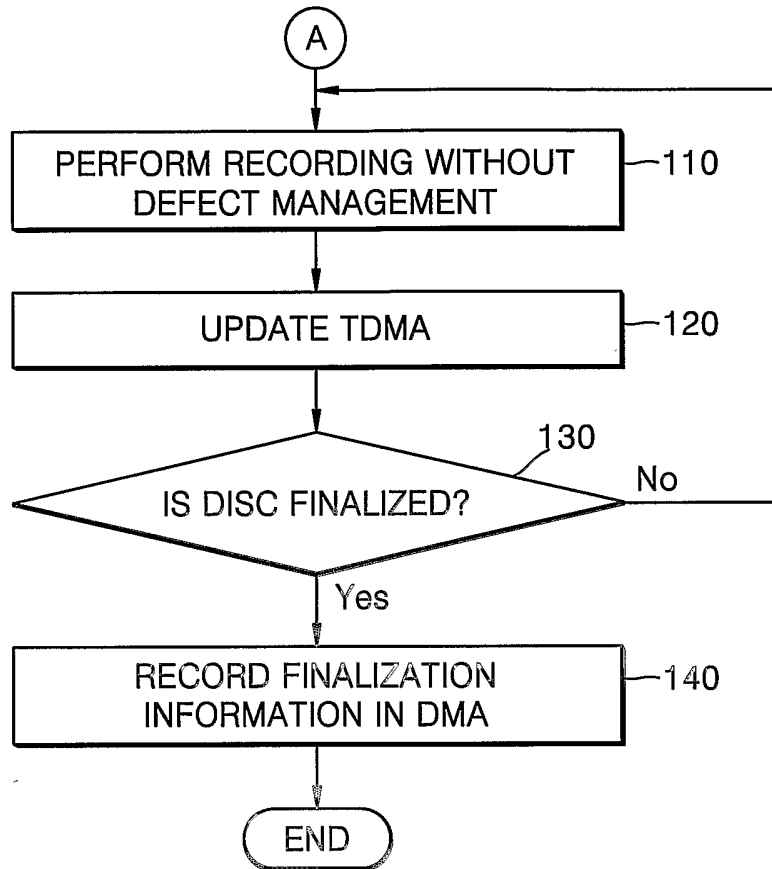
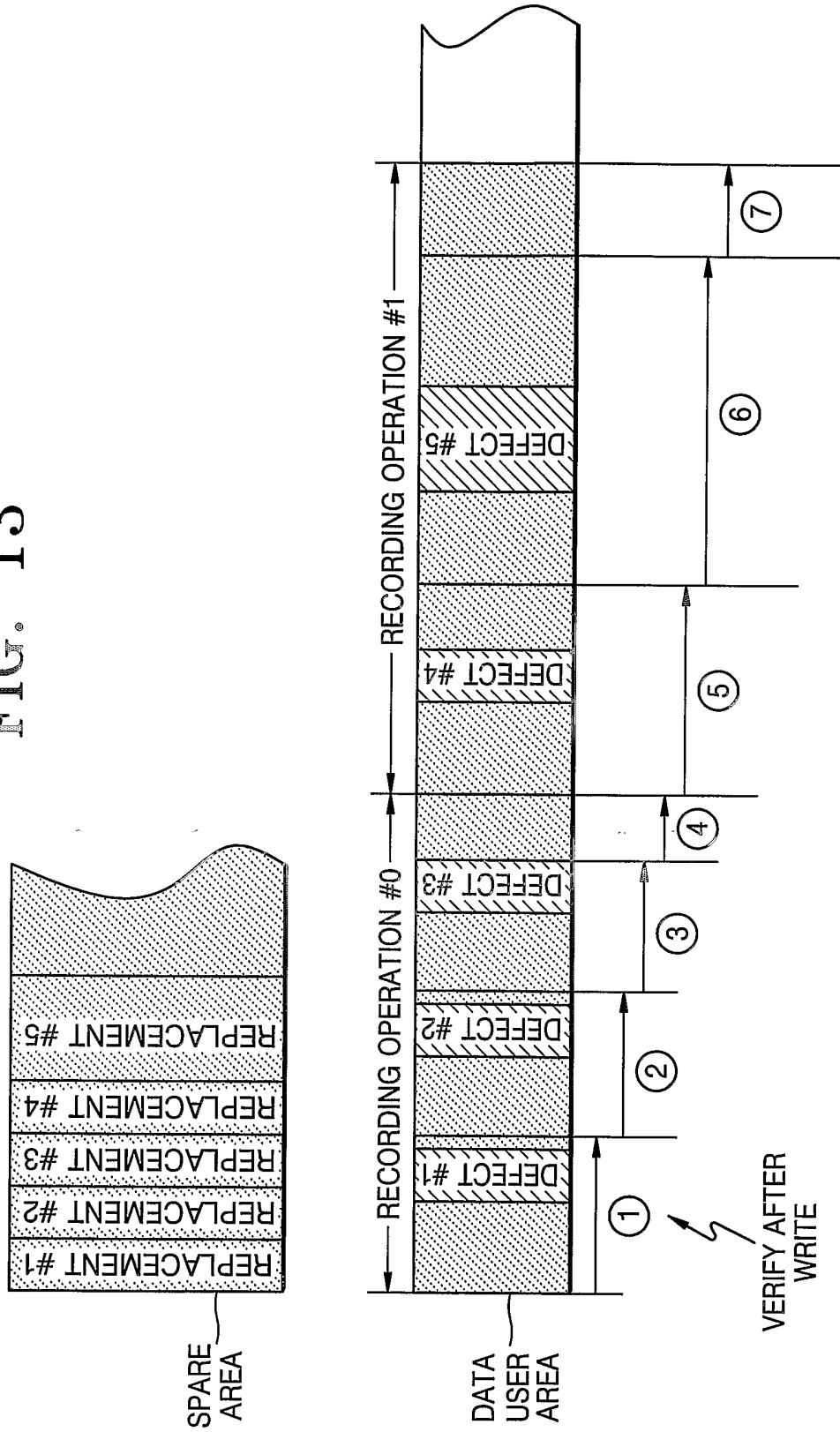

FIG. 13



INTERNATIONAL SEARCH REPORT

International application No.
PCT/KR2004/000862

A. CLASSIFICATION OF SUBJECT MATTER

IPC7 G11B 7/0045

According to International Patent Classification (IPC) or to both national classification and IPC

B. FIELDS SEARCHED

Minimum documentation searched (classification system followed by classification symbols)

G11B G06F

Documentation searched other than minimum documentation to the extent that such documents are included in the fields searched

Electronic data base consulted during the international search (name of data base and, where practicable, search terms used)

C. DOCUMENTS CONSIDERED TO BE RELEVANT

Category*	Citation of document, with indication, where appropriate, of the relevant passages	Relevant to claim No.
A	WO 00/54274 A1(Matsushita Electric Industrial Co. Ltd.) 14 September 2000 see the whole document	1-4, 7, 10, 13, 14, 16
A	WO 00/46805 A1(Matsushita Electric Industrial Co. Ltd.) 10 August 2000 see the whole document	1-4, 7, 10, 13, 14, 16
A	US 5940853(Matsushita Electric Industrial Co. Ltd.) 17 August 1999 see Abstract, all Claims	1-4
A	US 5978336(Sony Corporation) 2 November 1999 see Abstract, Claims 1-3, 12-14, 23	8, 9, 11, 12, 15, 17

Further documents are listed in the continuation of Box C.

See patent family annex.

* Special categories of cited documents:

"A" document defining the general state of the art which is not considered to be of particular relevance

"E" earlier application or patent but published on or after the international filing date

"L" document which may throw doubts on priority claim(s) or which is cited to establish the publication date of citation or other special reason (as specified)

"O" document referring to an oral disclosure, use, exhibition or other means

"P" document published prior to the international filing date but later than the priority date claimed

"T" later document published after the international filing date or priority date and not in conflict with the application but cited to understand the principle or theory underlying the invention

"X" document of particular relevance; the claimed invention cannot be considered novel or cannot be considered to involve an inventive step when the document is taken alone

"Y" document of particular relevance; the claimed invention cannot be considered to involve an inventive step when the document is combined with one or more other such documents, such combination being obvious to a person skilled in the art

"&" document member of the same patent family

Date of the actual completion of the international search

28 JUNE 2004 (28.06.2004)

Date of mailing of the international search report

29 JUNE 2004 (29.06.2004)

Name and mailing address of the ISA/KR



Korean Intellectual Property Office
920 Dunsan-dong, Seo-gu, Daejeon 302-701,
Republic of Korea

Facsimile No. 82-42-472-7140

Authorized officer

LEE, Bo Hyung

Telephone No. 82-42-481-5701



INTERNATIONAL SEARCH REPORT

Information on patent family members

international application No.

PCT/KR2004/000862

Patent document cited in search report	Publication date	Patent family member(s)	Publication date
WO 00/54274 A1	14.09.2000	US 20010043525 A1	22.11.2001
		US 6385148 B2	07.05.2002
		US 6304534 B1	16.10.2001
		US 6295257 B1	25.09.2001
		US 6292445 B1	18.09.2001
		US 6160778	12.12.2000
		JP 12-322838 A2	24.11.2000
		JP 12-322837 A2	24.11.2000
		JP 12-322836 A2	24.11.2000
		JP 12-322835 A2	24.11.2000
		JP 3075478 B2	14.08.2000
		JP 3075477 B2	14.08.2000
		JP 3040779 B2	15.05.2000
		EP 1043723 A1	11.10.2000
		EP 1041561 A2	04.10.2000
		EP 1041560 A2	04.10.2000
		EP 1041559 A2	04.10.2000
WO 00/46805 A1	10.08.2000	US 20030191980 A1	09.10.2003
		US 6581167 B1	17.06.2003
		JP 3090660 B2	25.09.2000
		JP 3090321 B2	18.09.2000
		JP 3090320 B2	18.09.2000
		JP 3090319 B2	18.09.2000
		JP 3090318 B2	18.09.2000
		JP 3090317 B2	18.09.2000
		JP 3090316 B2	18.09.2000
		EP 1239478 A1	11.09.2002
EP 1026681 B1	18.09.2002		
US 5940853	17.08.1999	JP 09-288884 A2	04.11.1997
US 5978336	02.11.1999	JP 10-112166 A2	28.04.1998