

(21) Application No: **1219433.8**  
(22) Date of Filing: **29.10.2012**  
(30) Priority Data:  
(31) **1118621** (32) **27.10.2011** (33) **GB**

(51) INT CL:  
**B62D 5/04** (2006.01)  
(56) Documents Cited:  
**EP 1958850 A1**  
(58) Field of Search:  
INT CL **B62D**  
Other: **EPODOC, WPI, TXTE**

(71) Applicant(s):  
**Jaguar Cars Limited**  
(Incorporated in the United Kingdom)  
Abbey Road, Whitley, COVENTRY, Warwickshire,  
CV3 4LF, United Kingdom

(72) Inventor(s):  
**Alex Bean**  
**Paolo Pucci**

(74) Agent and/or Address for Service:  
**Jaguar Cars Limited**  
PO Box W/1/073, Patent Department, Abbey Road,  
WHITLEY, Coventry, CV3 4LF, United Kingdom

(54) Title of the Invention: **Improvements in electric power assisted steering (EPAS) system**  
Abstract Title: **Electric power assisted steering with torque correction**

(57) The invention improves electric power assisted steering (EPAS) by providing a system 10 which is capable of receiving a detected value of steering wheel torque and is operable to improve the accuracy of the detected value of steering wheel torque by compensating for a weight imbalance present in the steering wheel 12. The gravitational effect of an off-centre mass such as an airbag typically varies with the steering wheel angle (alpha). The invention includes a program for subtracting a determined torque contribution due to the imbalance from a sensed torque to provide a corrected value of assistive motor torque. The angle of the steering wheel 12 relative to a horizontal plane is also taken into account. Values for the torque contribution can be contained in a look up table resulting from measurements under static conditions.

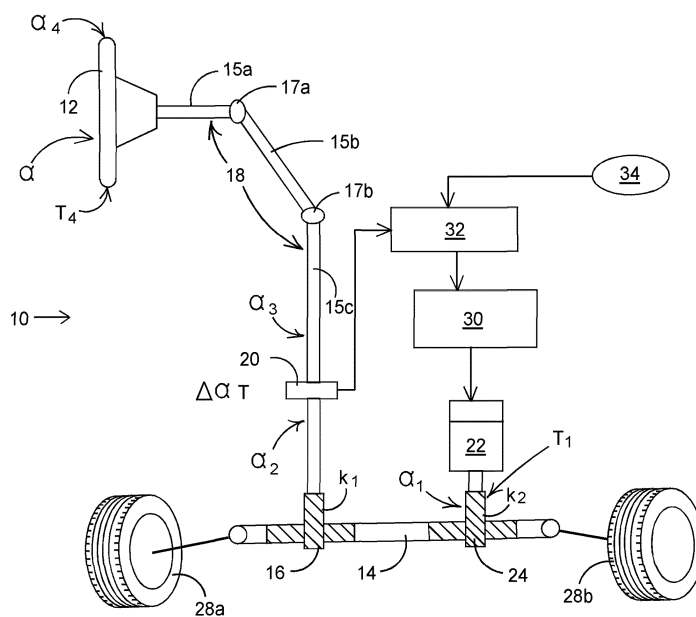

FIGURE 1

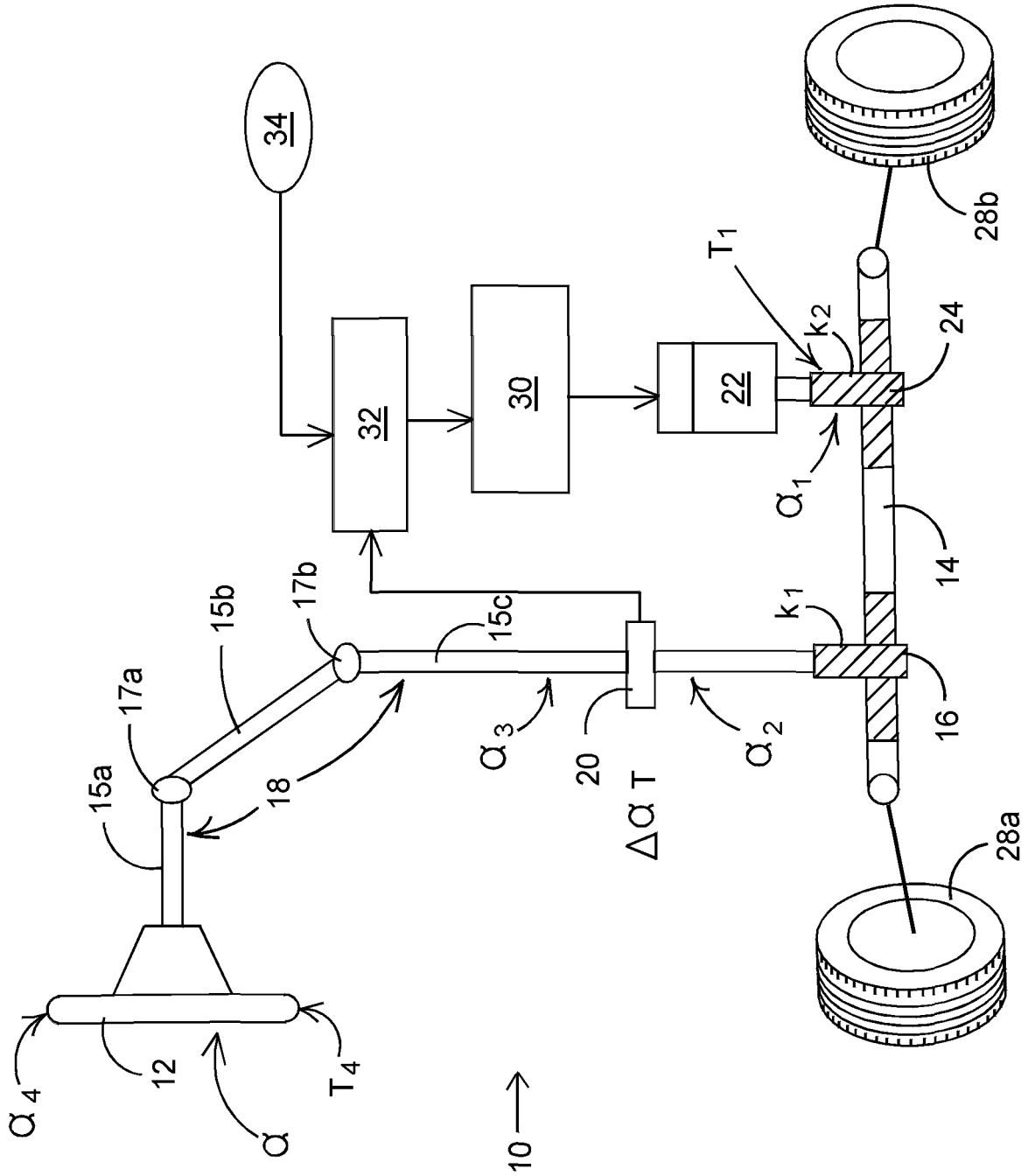

FIGURE 1

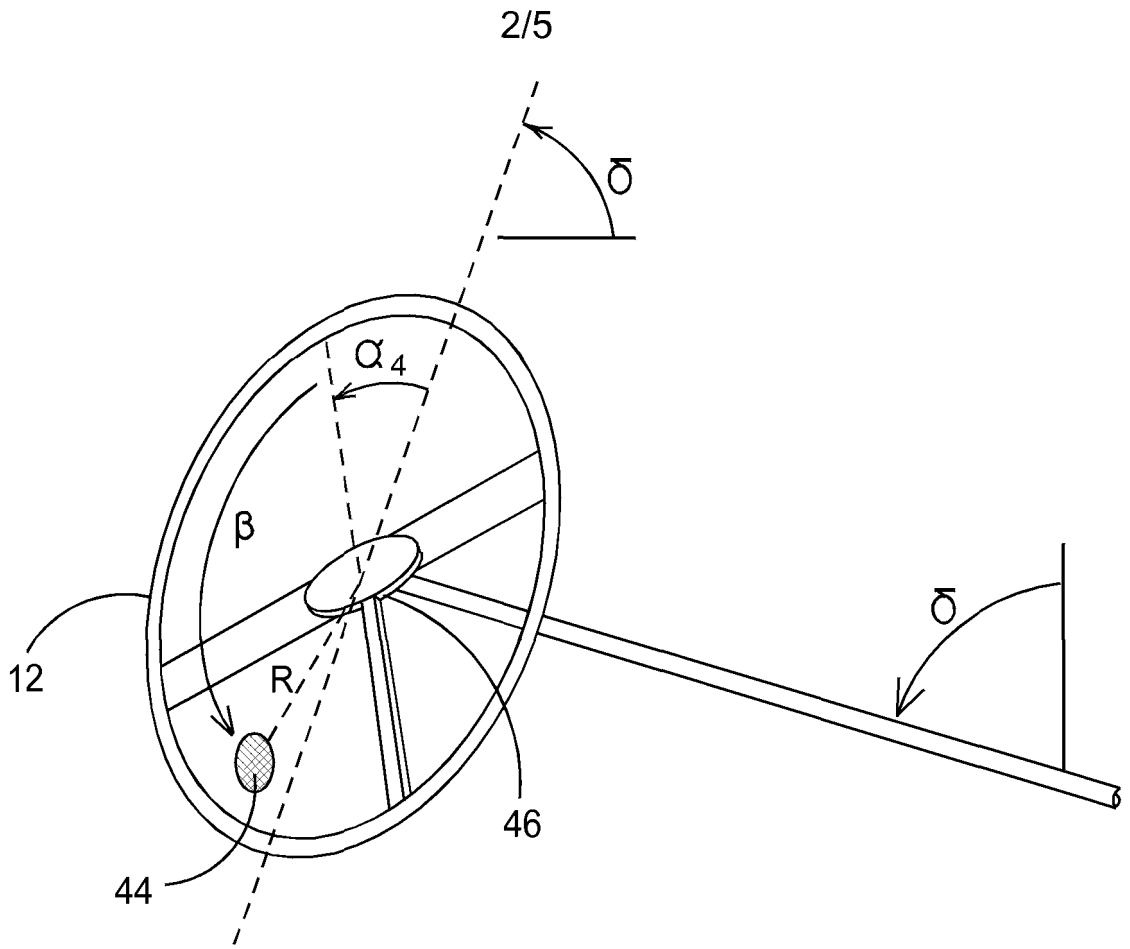

FIGURE 2A

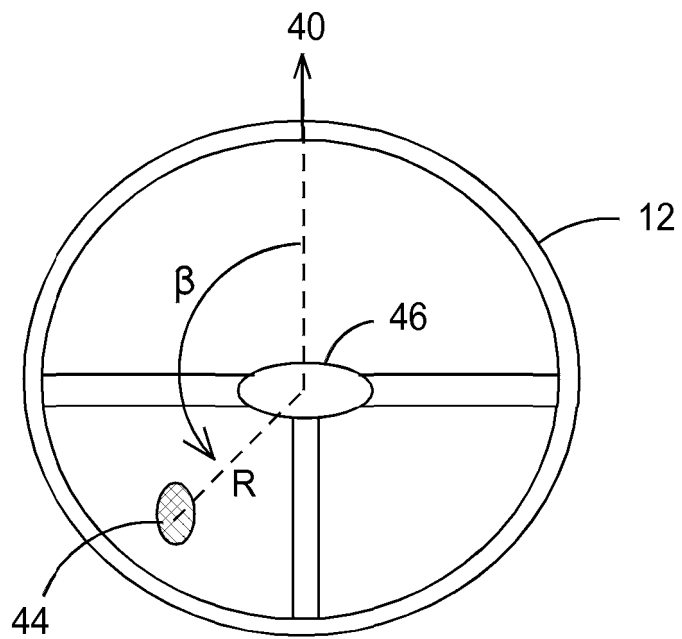

FIGURE 2B

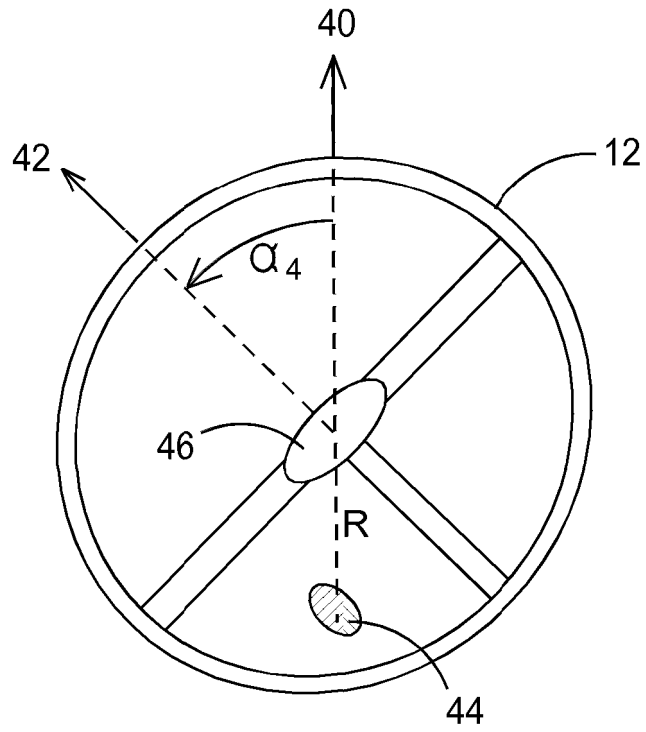

FIGURE 2C

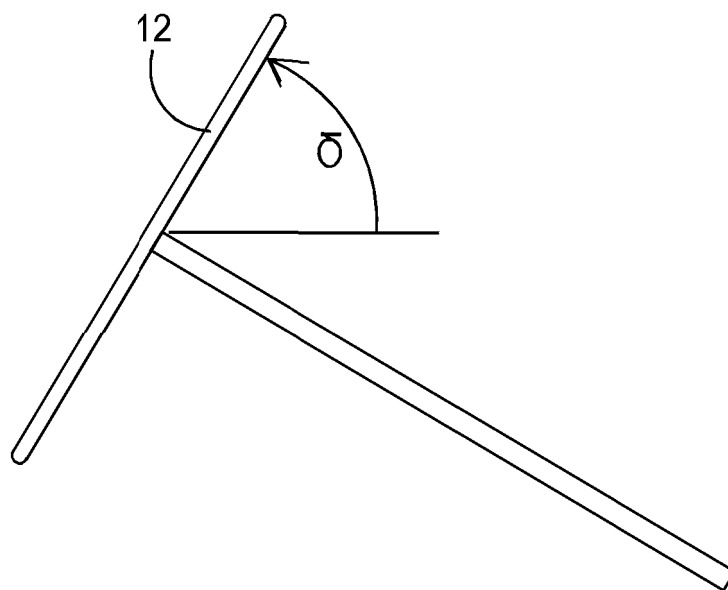

FIGURE 2D

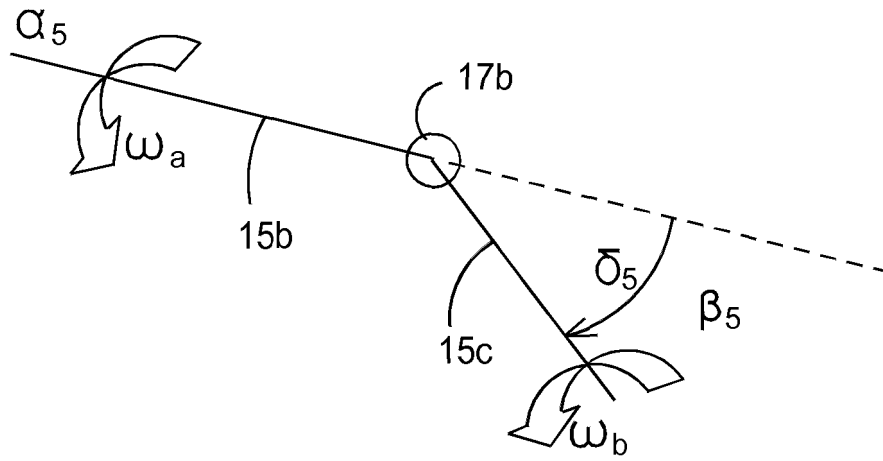

FIGURE 3

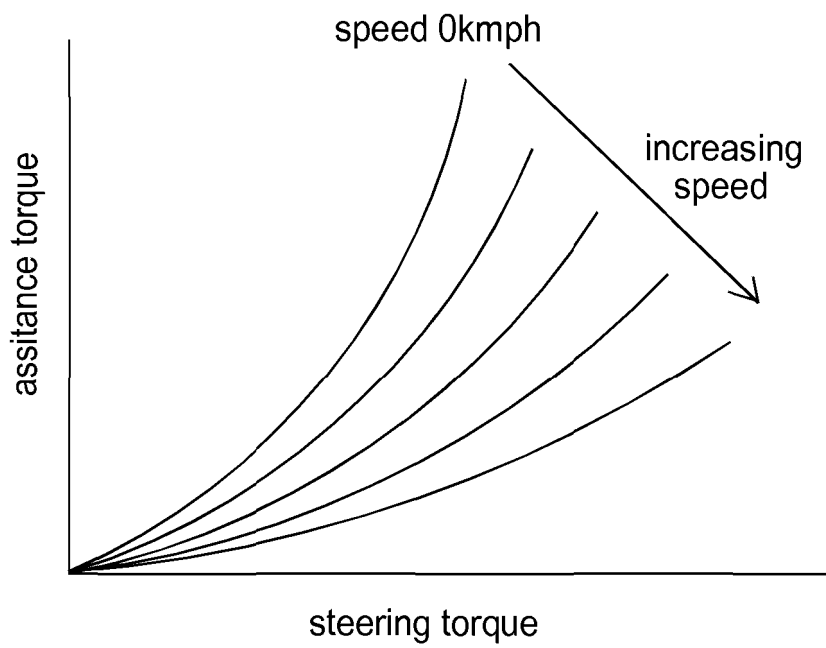

FIGURE 4

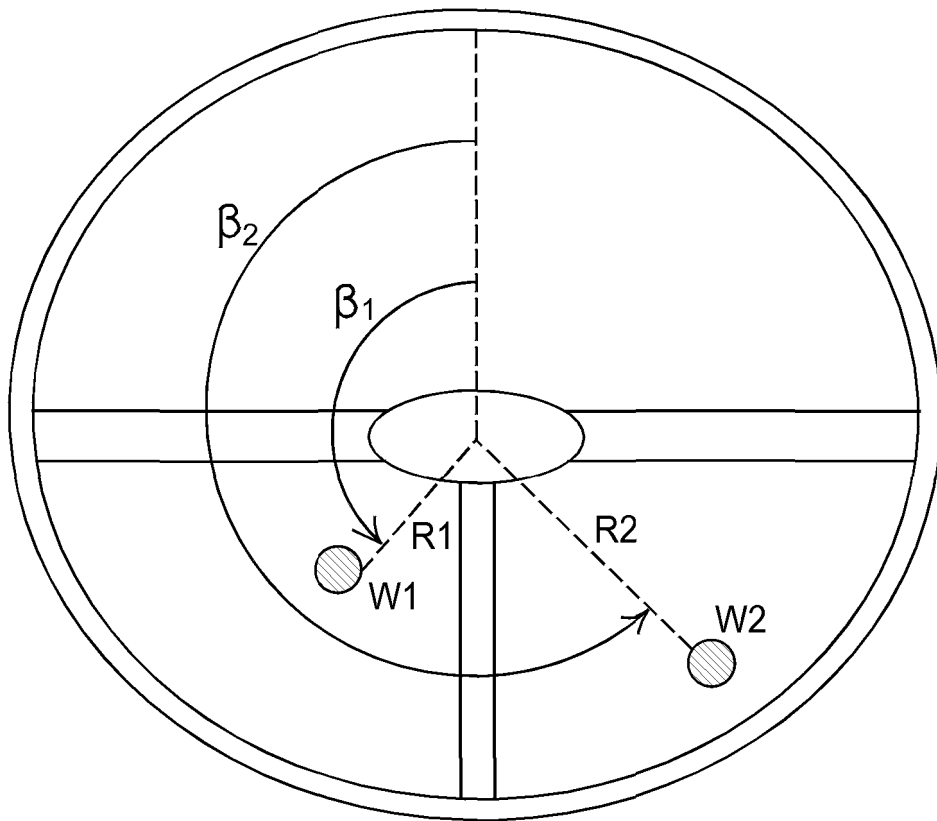

FIGURE 5

## IMPROVEMENTS IN ELECTRIC POWER ASSISTED STEERING (EPAS) SYSTEMS

### TECHNICAL FIELD

The present disclosure relates to a vehicle having an Electric Power Assisted Steering (EPAS or EPS) system and to an improvement in EPAS systems. More particularly, but not exclusively, the invention relates to an EPAS system configured to compensate for errors or inaccuracies of known EPAS systems. Aspects of the invention relate to an EPAS system, to a program, to a vehicle and to a method.

### 10 BACKGROUND ART

Electric Power Assisted Steering (EPAS or EPS) systems employ an electric motor to assist the driver in providing the amount of torque required to control the direction of the steered wheels of a vehicle for controlling the direction of the vehicle. Sensors disposed within the vehicle are used to detect the motion and torque of the steering wheel. A computer module calculates an amount of assistive torque to apply and instructs an electric motor, optionally, disposed on a rack between the steered wheels of the vehicle, (i.e. the wheels that are being moved) to apply that assistive torque. The steering system allows varying amounts of assistance to be applied depending upon the driving conditions. For example, if the vehicle is travelling forwards (typically the steered wheels are leading); or if the vehicle is travelling in a reverse direction (typically the steered wheels are trailing); or if the vehicle is cornering, the amount of assistive torque applied might need to be different. Similarly, dependent upon the speed of travel, a different amount of assistive torque may be needed. Typically, greater assistance is needed at slower speeds, but at higher speeds a lower amount of assistive torque may be appropriate, otherwise the driver might find the vehicle difficult to handle. For a particular restricted set of pre-determined conditions the assistive torque to be applied is found in a look up table or is calculated.

It is desirable in certain applications to carefully control the driving experience and for the handling of the vehicle experienced by the driver to meet very high standards. In executive or luxury cars it is desirable to provide a smooth driving feel with a high sense of driver control. In vehicles of a more sporting nature, a different feel of vehicle handling may be desired. It may even be desirable to provide both characteristics within the same vehicle and allow the driver to select between driving modes. It is an object of the present invention to provide an improved EPAS system. The present invention seeks to improve upon the EPAS systems of the prior art

by providing an EPAS system that may compensate for or otherwise mitigate some undesirable characteristics of known EPAS systems.

#### SUMMARY

5 According to one aspect of the invention, there is provided a vehicle comprising an electric power assisted steering (EPAS) system, wherein the EPAS system is configured to use at least an approximation of a torque contribution ( $T_{weight}$ ) to the steering wheel torque caused by the presence of one or more weights disposed in the steering wheel in an off-centre position to compensate for that torque contribution ( $T_{weight}$ ) by computing a corrected value of steering  
10 wheel torque from a detected value of steering wheel torque and/or to compensate for that torque contribution ( $T_{weight}$ ) by computing a corrected value of assistive motor torque.

Optionally, the corrected value of steering wheel torque may be computed by the EPAS system by subtracting the at least an approximation of the torque contribution ( $T_{weight}$ ) from the  
15 detected value of steering wheel torque as follows:

$$SensorTorqueCorrected = SensorTorque - T_{weight}.$$

The corrected derived assistive motor torque may be computed by the EPAS system by  
20 subtracting a scaled value of the at least an approximation of the torque contribution ( $T_{weight}$ ) from a derived value of assistive motor torque ( $T_1$ ) as follows:

$$MotorTorqueDemandCorrected = MotorTorqueDemand (T_1) - T_{weight} * k_1 / k_2.$$

25 Alternatively or in addition, the at least an approximation of the torque contribution ( $T_{weight}$ ) used by the EPAS system is calculated or is referenced from a look-up table of measured values.

30 According to another aspect of the invention, there is provided a vehicle comprising an electric power assisted steering (EPAS) system, wherein the EPAS system is capable of receiving a detected value of steering wheel torque and wherein the EPAS system is configured to improve the accuracy of the detected value of steering wheel torque by compensating for a weight imbalance present in the steering wheel.



Optionally, the EPAS system of any preceding paragraph may be configured to derive an assistive motor torque ( $T_1$ ) to be supplied by a motor of the EPAS system and the EPAS system may be configured to compensate for the influence of a weight imbalance present in the steering wheel by adjusting the derived assistive motor torque ( $T_1$ ) using a torque correction that is dependent upon steering wheel angle.

The EPAS system may be configured to compute the torque contribution ( $T_{weight}$ ) by: approximating the weight imbalance as one or more point masses and/or approximating the angular position of the mass and/or approximating the radial position of the mass and/or approximating the angular position of the steering wheel relative to a horizontal plane.

As yet a further option, the EPAS system may be configured to compute the torque contribution ( $T_{weight}$ ) as follows:

$$T_{weight}[Nm] = W[kg] \cdot R[m] \cdot g \cdot \sin(\alpha + \beta),$$

wherein, the weight imbalance is treated as a single point mass ( $W$ ), disposed at an angle ( $\beta$ ) from the straight ahead position, at a radius ( $R$ ) from the centre of the steering wheel, for a steering wheel angle of rotation ( $\alpha$ ) and factor ( $g$ ) is the acceleration due to gravity. Optionally, the factor ( $g$ ) is taken to be between about  $9 \text{ m/s}^2$  to about  $10 \text{ m/s}^2$  and/or taken to be  $9.81 \text{ m/s}^2$ .

Alternatively or in addition, the computation may further include a term to account for the steering wheel being positioned at an angle ( $\delta$ ) relative to a notional horizontal plane and the computation may at least approximate the torque contribution ( $T_{weight}$ ) as follows:

$$T_{weight}[Nm] = W[kg] \cdot R[m] \cdot g \cdot \sin(\alpha + \beta) \cdot \sin(\delta)$$

Optionally, the EPAS system may be configured to compensate for the torque contribution ( $T_{weight}$ ) of any weight imbalance present in the steering wheel or any weight imbalance present in both the steering when and the steering column by computing a corrected value of steering wheel torque from a detected value of steering wheel torque and/or may be configured to compensate for that torque contribution ( $T_{weight}$ ) by computing a corrected value of assistive motor torque ( $T_1$ ), and the EPAS system may be configured to refer to a look-up table

comprising a series of values of torque contribution (*Tweight*), wherein a torque contribution is provided for a given angle of rotation of the steering wheel ( $\alpha$ ).

5 The EPAS controller may be configured to compensate for the torque contribution (*Tweight*) by conducting a real-time interpolation of the torque contribution (*Tweight*) from the look-up table against the angle of rotation of the steering wheel. Optionally, the interpolation is any one of linear, quadratic, other polynomial or exponential. Further optionally, the values of torque contribution (*Tweight*) contained in the look-up table are measured under static conditions.

10 Additionally, the angle of rotation of the steering wheel may be a detected variable and the EPAS system may:

(i) use the detected angle of rotation of the steering wheel in a computation of the torque contribution (*Tweight*) or may use the detected angle of rotation of the steering wheel in a look-up table referencing the torque contribution (*Tweight*); or

15

(ii) improve the accuracy of the detected angle of rotation of the steering wheel by compensating for a phasing of the joints between any two linked components of the steering mechanism and may use the improved value of steering wheel angle ( $\alpha$ ) in a computation of the torque contribution (*Tweight*) or may use the improved value of steering wheel angle in referencing a look-up table of torque contributions (*Tweight*); or

20

(iii) improve the accuracy of the detected angle of rotation of the steering wheel ( $\alpha$ ) by compensating for the effect on steering wheel angle caused by deflection across the torque sensor due to the low-stiffness of the torque sensor and may use the improved value of steering wheel angle in a computation of the torque contribution (*Tweight*) or may use the improved value of steering wheel angle in referencing a look-up table of torque contributions (*Tweight*).

25

Optionally, a sensor for detecting the angle of rotation of the steering wheel may be disposed within the steering mechanism and may not be directly connected to the steering wheel.

30

The EPAS system may be further capable of receiving a second detected variable value or deriving a second variable value from a detected variable value and is operable to improve the accuracy of that second detected and/or derived variable value to at least partially eliminate any

discrepancy between the actual variable value and the second detected or derived variable value and wherein the second detected or derived variable is one of: steering wheel angle, steering angle velocity and motor angle.

5 The EPAS system may be configured to improve the accuracy of the second detected or derived variable value by compensating for any one or more of:

(i) an angular phasing of joints between any two linked components of the steering mechanism; and

10 (ii) the effect on steering wheel angle of the deflection across the torque sensor (20) at least substantially due to the low-stiffness of that torque sensor.

Optionally, the EPAS system may be configured to compensate for the effect of angular phasing of the joints between two linked components of the steering mechanism using any one or more of the following relationships:

15

$$\frac{\dot{\beta}_s}{\dot{\alpha}_s} = \frac{\omega_b}{\omega_a} = \frac{\cos \delta_s}{1 - \sin^2 \delta_s \cos^2 \alpha_s}$$

$$\beta_s = \arctan 2(\sin \alpha_s, \cos \alpha_s \cdot \cos \delta_s)$$

20

$$\alpha_s = \arctan 2(\sin \beta_s, \frac{\cos \beta_s}{\cos \delta_s})$$

As yet a further option, the second detected variable value is the angle of rotation of the steering wheel, and wherein the EPAS system is configured to compensate for the influence of the steering wheel torque sensor to improve the accuracy of the angle of rotation of the steering wheel used by the EPAS system to compute the amount of assistive torque supplied by the motor by determining and subtracting a displacement angle from the detected angle of rotation of the steering wheel.

30 According to another aspect of the invention, there is provided a method of assisting the steering of a vehicle, the method comprising:

(i) providing an electronic power assisted steering (EPAS) system having an EPAS control unit and a steering wheel torque sensor;

(ii) configuring the EPAS control unit to use at least an approximation of a torque contribution ( $T_{weight}$ ), caused by the presence of one or more weights disposed within the steering wheel in an off-centre position; and

5

(iii) configuring the EPAS control unit to compute a corrected value of steering wheel torque using said torque contribution ( $T_{weight}$ ); and/or

10

(iv) configuring the EPAS control unit to compute a corrected value of assistive motor torque using said torque contribution ( $T_{weight}$ ).

Optionally, the corrected value of steering wheel torque may be computed by subtracting said torque contribution ( $T_{weight}$ ) from the detected value of steering wheel torque as follows:

15

$$SensorTorqueCorrected = SensorTorque - T_{weight}.$$

Further optionally, the corrected derived assistive motor torque may be computed by subtracting a scaled value of said torque contribution ( $T_{weight}$ ) from a derived value of assistive motor torque ( $T_1$ ) as follows:

20

$$MotorTorqueDemandCorrected = MotorTorqueDemand (T_1) - T_{weight} \cdot k_1/k_2.$$

Alternatively, or in addition the method may comprise the step of determining the torque contribution ( $T_{weight}$ ) by a computation that comprises: approximating the weight imbalance as one or more point masses and/or approximating the angular position of the mass and/or approximating the radial position of the mass and/or approximating the angular position of the steering wheel relative to a horizontal plane.

25

Optionally, the step of determining the torque contribution ( $T_{weight}$ ) may comprise the following calculation:

30

$$T_{weight}[Nm] = W[kg] \cdot R[m] \cdot g \cdot \sin(\alpha + \beta),$$

wherein, the weight imbalance is treated as a single point mass ( $W$ ), disposed at an angle ( $\beta$ ) from the straight ahead position, at a radius ( $R$ ) from the centre of the steering wheel, the steering wheel having an angle of rotation ( $\alpha$ ) and factor ( $g$ ) is the acceleration due to gravity. Optionally, the factor ( $g$ ) to account for acceleration due to gravity may be taken to be between  
5 about 9 and about 10  $m/s^2$  and/or taken to be  $9.81m/s^2$ .

As a further option, the calculation may include a term to account for the steering wheel being positioned at an angle ( $\delta$ ) relative to a notional horizontal plane, the computation at least approximating torque contribution ( $T_{weight}$ ) as follows:

10

$$T_{weight}[Nm] = W[kg] \cdot R[m] \cdot g \cdot \sin(\alpha + \beta) \cdot \sin(\delta)$$

Optionally, the method may further comprise the step of determining the torque contribution by: referring to a look-up table comprising a series of values of torque contribution ( $T_{weight}$ ), each  
15 torque contribution for a given angle of rotation of the steering wheel, and the method including controlling the amount of assistive torque applied to the electric motor by conducting a real-time interpolation of the torque contribution ( $T_{weight}$ ) from the look-up table against the angle of rotation of the steering wheel.

20 According to yet a another aspect of the invention, there is provided a program for a computer for use in an EPAS system of a vehicle, the program containing one or more algorithms for carrying out the method of any of the relevant preceding paragraphs such that when running, the program is configured to at least approximately determine a torque contribution ( $T_{weight}$ ) or to reference an at least approximate torque contribution stored in a look-up table, caused by the  
25 presence of one or more weights disposed within the steering wheel in an off-centre position.

Optionally, the program may be capable of receiving a detected value of steering wheel torque and may be configured to improve the accuracy of the detected value of steering wheel torque by subtracting the determined or referenced torque contribution ( $T_{weight}$ ) from the detected  
30 value of steering wheel torque as follows:

$$SensorTorqueCorrected = SensorTorque - T_{weight}.$$

Further optionally, a corrected derived assistive motor torque may be computed by subtracting a scaled value of the determined or referenced torque contribution ( $T_{weight}$ ) from a derived value of assistive motor torque ( $T_1$ ) as follows:

5  $MotorTorqueDemandCorrected = MotorTorqueDemand (T_1) - T_{weight} * k_1 / k_2.$

Within the scope of this application it is envisaged that the various aspects, embodiments, examples, features and alternatives set out in the preceding paragraphs, in the claims and/or in the following description and drawings may be taken independently or in any combination  
10 thereof. For example, features described in connection with one embodiment are applicable to all embodiments unless there is incompatibility of features.

#### BRIEF DESCRIPTION OF THE DRAWINGS

Embodiments of the invention will now be described, by way of example only, with reference to  
15 the accompanying drawings, in which:

FIGURE 1 is a schematic illustration of a vehicle and EPAS system;

FIGURE 2A is a perspective view, schematically illustrating a steering wheel having an off-  
20 centre mass;

FIGURE 2B is an end view schematically illustrating the steering wheel of Figure 2A in its centre non-rotated or "zero" position;

25 FIGURE 2C is an end view schematically illustrating the steering wheel of Figure 2A in an anti-clockwise rotated position, having been moved  $\alpha_4$  radians away from the "zero" position;

FIGURE 2D is a side view schematically illustrating the steering wheel of Figure 2A;

30 FIGURE 3. is a schematic illustration of a pair of jointed shafts that may be comprised in the vehicle system of Figure 1;

FIGURE 4 is a tuning map of the assistive torque that an electric motor typically applies for a given vehicle speed and detected driver torque; and

FIGURE 5 is an end view, schematically illustrating a steering wheel having more than one off-centre mass.

- 5 The following table 1.1 lists the reference symbols used in the drawings along with a brief description of the feature that they reference.

REFERENCE SYMBOL	BRIEF DESCRIPTION	REFERENCE SYMBOL	BRIEF DESCRIPTION
10	EPAS system	$\beta_1$	Angle of first offset mass
12	Steering wheel	$R_1$	Radial position of first offset mass
14	Rack bar	$T_4$	Driver applied torque at the steering wheel
15a, 15b, 15c	Shafts	$\alpha_3$	Shaft angle at the torque sensor
16	Steering gear	$\alpha_2$	Shaft angle at the rack
17a, 17b	Joints	$\alpha_1$	Motor angle
18	Collectively, the shafts and joints connecting the steering wheel to the steering gear	$T_1$	Motor torque
20	Torque sensor	$R$	Distance of weight in steering wheel from the centre of the steering wheel
22	Electric motor	$k_1, k_2$	Gears
24	Connection between the electric motor and the rack	$\alpha$	Actual angle of rotation of steering wheel
28a, 28b	Wheels (road wheels)	$\alpha_4$	Angle of rotation of the steering wheel measured at the steering wheel
30	Motor controller	$\alpha_5$	Input angle at joint
32	EPAS controller unit	$\beta_5$	Output angle at joint
34	Sensor inputs	$\delta_5$	Angle between two jointed shafts

44	Off-set mass	$\Delta\alpha$	Angle displacement through the torque sensor
46	Steering wheel centre	T	Torque as measured by the torque sensor
$\beta$	Angle of point weight in unbalanced steering wheel	$\omega_b$	Angular velocity at output of joint
$\delta$	Angle of steering wheel relative to horizontal notional plane	$W_2$	Second offset mass
$\omega_a$	Angular velocity at input of joint	$\beta_2$	Angle of second offset mass
$W_1$	First offset mass	$R_2$	Radial position of second offset mass

DETAILED DESCRIPTION

Detailed descriptions of specific embodiments of the EPAS system, control units therefor and vehicles employing the same are disclosed herein. It will be understood that the disclosed embodiments are merely examples of the way in which certain aspects of the disclosure can be implemented and do not represent an exhaustive list of all of the ways the disclosure may be embodied. Indeed, it will be understood that the EPAS system, control units therefor and vehicles employing the same as described herein may be embodied in various and alternative forms. The figures are not necessarily to scale and some features may be exaggerated or minimised to show details of particular components. Well-known components, materials or methods are not necessarily described in great detail in order to avoid obscuring the present disclosure. Any specific structural and functional details disclosed herein are not to be interpreted as limiting, but merely as a basis for the claims and as a representative basis for teaching one skilled in the art to variously employ the disclosure.

In the specification reference is made to the term "torque" (also known as moment or moment of force), unless otherwise stated, this is to be taken to have its normal meaning being a turning force. The S.I. unit of measurement of torque is Nm and in the specification Nm are typically used.



Referring to Figure 1 there is shown a schematic illustration of a vehicle comprising an EPAS system 10 wherein a steering mechanism comprises a steering wheel 12 coupled to a rack bar (also referred to simply as rack) 14 through gearing 16 (typically a pinion gear) and a combination of linked components comprising shafts 15a, 15b, 15c coupled to one another by joints 17a, 17b respectively (labelled collectively as 18). Road wheels 28a, 28b which can be used to control the vehicle direction are coupled to each end of the rack bar 14. A torque sensor 20 is positioned between the steering wheel 12 and rack 14. Typically, the torque sensor 20 includes a low-stiffness torsion bar and is used to measure the torque applied by the driver to the steering wheel 12 (referred to as the "measured steering wheel torque" or "detected steering wheel torque" or "driver torque"). This allows the in-line measurement of torque to be made; in alternative embodiments a reaction torque sensor may be employed. The power assistance is provided by an electric motor 22 that is coupled to the rack bar 14 by means of gearing 24. In other envisaged embodiments a belt may be employed to couple the electric motor 22 to the rack bar 14. The electric motor 22 is coupled to and controlled by a motor controller unit 30 (such as a computer or central processing unit). Optionally, the motor controller unit 30 is coupled to an EPAS controller 32 (which may take the form of a programmable, processing unit).

The torque sensor 20 and other input sensors (collectively labelled as 34) are coupled to the EPAS controller unit 32. This is depicted schematically in Figure 1. Information detected by the input sensors 34, for example, vehicle speed, temperature and steering angle is monitored by the EPAS controller unit 32. The EPAS system 10 typically requires at least one measurement of the current actual steering wheel angle  $\alpha$ . The steering wheel angle  $\alpha$  can be measured at one or more different positions within the steering system. A steering wheel angle measurement  $\alpha_4$  directly at the steering wheel 12 is not typically made, but rather a steering wheel angle measurement is carried out at one or more locations distant from the steering wheel 12 using sensors, which may for example, be located at the positions indicated by  $\alpha_1$ ,  $\alpha_2$ , and  $\alpha_3$  as shown in Figure 1. The data detected by the torque sensor 20 is also monitored by the EPAS controller unit 32, as such the EPAS controller unit 32 is provided with a determined or detected value of the steering wheel torque  $T$ , that is at least proportional to the torque  $T_4$  applied by the driver. Based upon received data and/or pre-programmed algorithms and/or look-up tables, the EPAS controller 32 computes an assistance torque  $T_1$ . In Figure 4 an illustration of a look-up map is shown, wherein for a given determined or measured driver demand or steering wheel torque at a particular vehicle speed, a value of assistance torque  $T_1$  is provided. This

information is conveyed to and translated by the motor controller unit 30 into a current or live torque demand  $T_1$  for the electric motor 22. The electric motor 22 is thereby configured to provide the required assistance torque  $T_1$  to the rack 14 to turn i.e. steer the wheels 28a, 28b.

5 In a typical open loop EPAS controller, a required assistance torque is generated by the EPAS controller 32, which collates the data received from the input sensors 34, and then passes the inputs through a combination of filters and algorithms, whose characteristics are tuned to determine steering characteristics of the vehicle (for example, as per Figure 4). The steering characteristics of the vehicle may be changed by the driver of the vehicle, depending upon the  
10 type of driving and driving conditions.

Alternatively, in closed loop EPAS systems, the EPAS controller 32 unit calculates a desired reference driver torque. This desired reference torque (also referred to as referenced driver torque) is based upon the data inputs from the sensors and/or pre-programmed algorithms  
15 and/or look-up data available in tables. The electric motor 22 is controlled to apply a corresponding assistive torque such that the actual driver torque is matched to the reference torque at least as closely as possible. In this way the torque required by the driver to control the vehicle is itself controlled by the EPAS system so that the driving experience and handling of the vehicle as perceived by the driver is controlled.

20

One advantage of the present invention provides an improved EPAS system 10 in which inaccuracies or "error states" that are present in known EPAS systems 10 (for both open and closed loop controllers) are compensated for.

25 The EPAS system 10 herein described is capable of receiving a detected variable value or deriving a variable value from a detected variable value. The new EPAS system 10 is configured to improve the accuracy of the detected and/or derived variable value to at least partially eliminate any discrepancy between the actual variable value and the detected or derived variable value. The EPAS system 10 is configured to control the amount of assistive  
30 torque supplied by an electric motor 22 of the EPAS system 10 based upon, (among other factors) the improved variable value.

One possible source of deviation between the detected or derived variable arises from the fact that steering wheels 12 typically comprise features 44 such as air bags, control devices and

safety features (as examples), as such the weight of the steering wheel (and for these and other reasons also the steering column) may not be uniformly distributed around its centre of rotation and this can generate an undesired fluctuating torque. In other words, the steering wheel system behaves as if there was an off-centre mass, offset from the axis of rotation and this offset mass can generate an undesired and fluctuating torque that is referred to herein as 'Tweight'. The value of torque contribution (*Tweight*) is dependent on the actual or true angle  $\alpha$  of the steering wheel 12.

One of the impacts of the additional and fluctuating torque attributable to the offset weight or uneven weight distribution of the steering wheel 12 on the input side of an EPAS system 10, is that the torque contribution (*Tweight*) effects the measured torque signal T. This is because the torque sensor 20 cannot distinguish between the component of the measured or sensed torque that is attributable to the weight imbalance in the steering wheel 12 (*Tweight*) and the genuine torque  $T_4$  applied by the driver. For example, if the driver is applying a constant torque  $T_4$ , and the steering wheel 12 is rotating at a constant speed, the torque T actually measured by the sensor 20 is not constant, but rather contains a fluctuation that is dependent upon the steering wheel angle ( $\alpha$ ). This in turn has an impact (for example causes non-linearity) on the steering feel.

Another impact of the offset mass 44 appears on the output side of an EPAS system 10. The torque contribution (*Tweight*) is a torque that the electric motor 22 needs to "fight" against. For example, if the electric motor 22 is providing a constant torque, this does not translate into a linear motion (constant angular velocity) of the steering wheel, because when the offset weight 44 is "lifted", the steering wheel velocity will drop, and likewise, when the weight is "falling" the steering wheel velocity will increase (due to the extra momentum of the weight). This is a source of non-linearity in the steering feel of current EPAS systems, which the present invention seeks to at least mitigate against if not entirely remove.

In an optional aspect of the present invention it is also identified that the geometry of the joints 17a, 17b and shafts 15a, 15b, 15c in a typical EPAS system 10 is such that a variation in the angle  $\alpha$  through which the steering wheel 12 has been turned or rotated does not necessarily correspond to an equal variation in the angle of the output shaft  $\alpha_3$  (see Figures 1 and 3). This is considered to be because each joint 17a, 17b introduces a different angular phasing between the angle at its input shaft (for example  $\alpha_4$ ) and the angle at its output shaft (for example  $\alpha_3$ ).

See Figure 1, wherein a rotation of shaft 15a does not cause an equal rotation of shaft 15b because the two shafts 15a, 15b are disposed at an angle relative to one another and are connected by a joint 17a.

5 The present invention seeks to mitigate certain undesirable effects of these and other factors or "error states". In the following embodiments it is described how the unbalanced weight of the column and steering wheel and joint geometry may be compensated for or entirely mitigated. Other components of the steering system, such as the torque sensor 20 itself are considered to be responsible for certain other inaccuracies and ways of mitigating these inaccuracies are also  
10 included within optional aspects of the invention.

Beneficial aspects of the described invention are summarised in the following list:

(1) one described embodiment provides a solution for the compensation of the unbalanced weight of the steering wheel;

15

(2) another embodiment provides a further solution for the compensation of an unbalanced weight of the steering column and/or steering wheel;

20

(3) yet another embodiment provides a way of compensating for the effect of joint geometry on steering wheel angle, on steering wheel angular velocity and on steering torque; and

25

(4) a further embodiment provides another way in which the influence of the torque sensor on steering wheel angle can be compensated for.

30

It will be understood upon reading the foregoing that other approximations for compensating for these and other errors may be utilised to refine the steering in an EPAS system 10. Additionally it will be understood that these compensations may be used alternatively to one another or if applicable, in any combination with one another.

In the illustrations accompanying the description, like features have where applicable been denoted by like reference numerals.

In one embodiment of the invention, an EPAS system 10 for a vehicle is described, in which an EPAS controller 32 is configured to control the amount of assistive torque supplied by an electric motor 22 of the EPAS system 10 based upon factors including consideration of a weight imbalance present in the steering wheel.

5

In order to be compensated for, a torque contribution ( $T_{weight}$ ) resulting from one or more offset weights 44 needs to be determined, advantageously as a function of the steering wheel angle  $\alpha$ . This is because the amount of constructive or destructive torque resulting from the presence of one or more off-set non centre masses 44 in the steering wheel 12 (and not resulting from the driver applied torque) changes with the angle of rotation  $\alpha$  of the steering wheel 12. In one  
10 embodiment, torque contribution ( $T_{weight}$ ) is determined by an analytical approach. Optionally, a computation of torque contribution due to off-set mass(es) 44 is carried out substantially continuously in real-time so that the EPAS system 10 is substantially continuously capable of compensating for the torque contribution due to off-set mass(es) 44.

15

The weight imbalance may be taken to be entirely due to the weight 44 in the steering wheel 12 and the torque contribution to any weight imbalance resulting from the steering column is optionally ignored in this specific embodiment. Additionally, the distributed weight is optionally treated as one or more point masses 44 (optionally measured in kilograms (kg)), placed at a  
20 distance R (measured in metres (m)) from the centre 46 of the steering wheel 12, at an angle of  $\beta$  (measured in radians (rad) from the straight ahead or dead centre position 40, which may be considered as when  $\alpha=0$ ). In Figures 2A and 2B schematic illustrations of a steering wheel 12 are provided in which a point mass 44 is shown at a position  $\beta$  radians from the straight ahead position or "zero point" 40 and at a distance R from the centre 46 of the steering wheel 12.  
25 When the steering wheel 12 is rotated away from the "zero point" 40 (see Figure 2C) to an actual steering wheel angle of  $\alpha$  (rad), the mass 44 is at an overall angle  $\gamma$  which is calculated as follows:

30

$$\gamma = (\alpha + \beta) \text{ [in radians]}$$

The steering wheel 12 of a vehicle is typically positioned at an inclined angle within the vehicle for ergonomic performance and to enhance driver comfort. The steering wheel 12 may therefore rotate in a plane placed at an angle  $\delta$  from a horizontal plane. The torque contribution ( $T_{weight}$ ) due to the off-set mass 44 may therefore be computed as:

$$T_{weight}[Nm] = W[kg] \cdot g[m/s^2] \cdot R[m] \cdot \sin(\gamma) \cdot \sin(\delta)$$

Wherein the factor  $g$  accounts for acceleration due to gravity which may be taken to be about  
5  $9.81 \text{ m/s}^2$ . In other embodiments a more approximate computation of the torque contribution  
( $T_{weight}$ ) may be carried out and the factor ( $g$ ) to account for acceleration due to gravity may  
optionally be taken to be between about 9 and about  $10 \text{ m/s}^2$ .

(In the above equation ‘.’ is used as the standard symbol for multiplication and can be read as  
10 equivalent to the often used multiplication symbol ‘x’).

The values  $W$ ,  $g$ ,  $R$ ,  $\beta$  are all constants, vehicle dependent and known in advance. Therefore,  
these values can be provided to the EPAS controller 32 for carrying out the torque contribution  
( $T_{weight}$ ) calculation for a vehicle. These values may be approximated or rounded to facilitate  
15 the EPAS controller’s computation. Furthermore, the computation of torque contribution  
( $T_{weight}$ ) may be carried out in any mathematically suitable order and not necessarily as a  
single calculation as written above.

$\delta$  may be a constant value (hence known), or may vary within a specified range (for example, in  
20 vehicles having height-adjustable or rake-adjustable steering columns). In the latter case, in  
some embodiments, the value of  $\delta$  may be available (through measurement or by knowing  
which position, of a limited set of position selections, the steering wheel 12 has been put into).  
However, if the value of  $\delta$  is variable and cannot be determined, a default value for  $\delta$  may be  
used (for example the intermediate value between the minimum and maximum steering wheel  
25 12 adjustment positions). Alternatively the computation of torque contribution ( $T_{weight}$ ) may, in  
some embodiments exclude the term  $\sin(\delta)$  or may include the term, but set  $\delta$  equal to  $\pi/2$   
radians in order for the term  $\sin(\delta)$  to equal 1 and thereby render it a mute term in order to  
simplify the computation. A detected value of steering wheel angle  $\alpha_1$ ,  $\alpha_2$ ,  $\alpha_3$ ,  $\alpha_4$  (from which  $\gamma$   
can be derived) is provided to the EPAS controller unit 32 as one or more data signals from a  
30 direct sensor disposed at the steering wheel 12 and/or from one or more indirect sensors 34 or  
other measurement means, in real time.

For every value of the steering wheel angle  $\alpha$ , the torque to be compensated for can therefore  
be computed. The real-time calculation of torque contribution ( $T_{weight}$ ) is a signal usable by the

EPAS controller 32 in calculating the assistance torque  $T_1$  that should be applied to the rack 14 by the electric motor 22.

5 As the steering wheel 12 is turned (as shown in Figure 2C) the point mass 44 provides a positive additional contribution to the torque applied by the driver. In this instance the calculated torque contribution ( $T_{weight}$ ) is a component of the measured driver applied torque  $T_4$  that is false and can be compensated for by subtracting the torque contribution ( $T_{weight}$ ) from the measured driver applied torque  $T_4$ . The false component of the measured driver applied torque  $T_4$  can be compensated for by providing less assistive torque than would otherwise be provided  
10 by the EPAS system 10.

Conversely, if the driver rotates the steering wheel 12 such that he has to lift the mass 44, the presence of the offset weight 44 imparts a torque ( $T_{weight}$ ) that opposes and acts against the torque applied by the driver. (In the illustrated example this could be a rotation to the right from  
15 the straight ahead position 40). The weight  $W$  of mass 44 provides a negative additional contribution to the torque  $T_4$  applied by the driver. In this instance the calculated torque contribution ( $T_{weight}$ ) has a negative value and by subtracting this false torque contribution ( $T_{weight}$ ) from the measured driver torque, the actual driver torque that should be used for the purpose of calculating the amount of assistive torque to apply is increased.

20

It will be understood from the foregoing that the compensation for the presence of a weight imbalance present in the steering wheel 12 can be carried out in a number of ways. One example of an analytical approach to compensating for the effect of one weight imbalance in a steering wheel has been described, however, it is envisaged that many and various other ways  
25 for approximating or determining the effect of the weight imbalance and correcting for the same will be suitable for carrying out the invention. Furthermore, the aforescribed approach may be varied in accordance with the teaching of the present invention. For example, it is envisaged that more than one point mass(es) 44, at different locations on or within the steering wheel 12 could be included (to compensate for say an air bag at one location and an infotainment switch-  
30 pack or similar control device located at another).

Furthermore, whereas the mass 44 has been treated as a single point mass 44 at a position  $R$  from the centre, a computation to compensate for the effects of one or more equivalent distributed offset masses in a steering wheel 12 could be carried out. Similarly, if there is more

than one “single-point” mass to be compensated for, they can be included in the torque contribution (*Tweight*) computation. Figure 5 illustrates a steering wheel 112 having two off-centre masses each treated as a separate single point mass  $W_1, W_2$ , at a radius from the centre of  $R_1, R_2$  respectively and at an angle  $\beta_1, \beta_2$  from the “zero” or straight ahead position.

5 Compensating for more than one mass or a distributed rather than single point mass may optionally be done by computing a torque contribution (*Tweight*) for each mass and summing the total torque contribution (*Tweight*) or alternatively or in combination, an overall calculation of the torque contribution (*Tweight*), may include, as an input variable, a Mass Position Product term (as set out below). A Mass Position Product input may optionally be incorporated into the  
10 computation of torque contribution (*Tweight*) or may be pre-calculated and optionally available as an input to that calculation. A Mass Position Product term may be defined as follows:

$$\text{MassPositionProduct} = \sum_{i=1}^n W_i \cdot R_i \cdot \sin(\alpha + \beta_i)$$

15 Wherein  $W_i$  is the mass at position  $i$ ,  $R_i$  is the radial distance of mass  $i$  from the steering wheel centre and  $\beta_i$  is the angular offset from the “zero” or straight ahead position of that mass  $i$ . The sum is carried out for each mass  $i$  to  $n$  comprised in the steering wheel or being compensated for.

20 It will also be understood that including the angle of incline  $\delta$  of the steering wheel in a computation of the torque contribution (*Tweight*) is entirely optional and in some envisaged embodiments, the torque contribution (*Tweight*) computation will not include this; in other embodiments a fixed parameter may be used instead of  $\sin(\delta)$  in order to make the computation of torque contribution (*Tweight*) easier to compute by the control unit processor 32 of the EPAS  
25 system. This may give a more approximate value, but nevertheless the variable torque contribution (*Tweight*) computed could still be used to correct or improve the accuracy of the measured steering wheel torque and would still vary based upon steering wheel angle.

It will also be understood that alone, or in combination with the above mentioned  
30 approximations, that the calculation of  $\sin(y)$  may be done in a number of ways in order to simplify the computation and thereby reduce the processing time needed in order to compute torque contribution (*Tweight*). Specifically it is envisaged that  $\sin(y)$  may be computed by using an expansion series such as a Taylor expansion series; or that  $\sin(y)$  may be provided in a look



up table which the EPAS controller unit 32 would refer to in order to compute a value of torque contribution (*Tweight*). Such a look-up table would likely comprise a series of values for sin( $\gamma$ ) at discrete given steering wheel angles ( $\alpha$ ) because  $\beta$ , the angle or position of a mass, could be determined and programmed into the EPAS systems. The values of sin( $\gamma$ ) provided in the look-up table may be linearly interpolated, quadratically interpolated, exponentially interpolated or interpolated using any other suitable mathematical method that would provide a suitable approximate value for sin( $\gamma$ ) that would be appropriate to use in the computation of torque contribution (*Tweight*) for a detected or derived value of steering wheel angle  $\alpha$  not listed in the look-up table but falling between values of detected or derived value of steering wheel angle  $\alpha$  that are listed.

Furthermore, it will be understood that whereas the initial calculation of torque contribution (*Tweight*) incorporates a value of gravity  $g$  for converting the mass 44 into a weight, the value of  $g$  used in the computation may be approximated to any suitable degree of accuracy. It is expected that a value of 10 may be used in some embodiments, and it is envisaged that any value from about 9 to about 10 would be suitable. In other embodiments, the conversion of the mass 44 into a weight  $W$  may be done outside of the computation of torque contribution (*Tweight*) and the weight  $W$  inserted as a variable input into the computation of *Tweight*. Alternatively, a variable of Weight Position Product (WPP) may be input into the computation of *Torque contribution (Tweight)* for only one mass. In other embodiments, the factor  $g$  for converting from mass 44 to weight may be included in the calculation of the mass position product as follows (wherein  $g$  may be any suitable fixed value such as 10, 9.8 and others.)

$$WeightPositionProduct(WPP) = gx \sum_{i=1}^n W_i . R_i . \sin(\alpha + \beta_i)$$

The preceding paragraphs describe manners in which the computation of torque contribution (*Tweight*) may be simplified or approximated in order to accommodate processing of the computation by the EPAS controller 32. Various ways of simplification and approximation may be carried out and the above description provides only examples as to how an algorithm may be constructed, there being many and various ways that one skilled in the art, upon reading the foregoing, would understand as suitable for computing a value of torque contribution (*Tweight*) to be used to compensate for one or more weight imbalances in a steering wheel 12.

In later described embodiments, it will be explained how the EPAS controller 32 of the system described herein is configured to improve upon the accuracy of one or more detected values of the steering wheel angle  $\alpha$ . Any of the originally detected values or improved values of steering wheel angle can be used for the purposes of calculating or computing an approximation of torque contribution (*Tweight*). Whereas it is expected that using an improved value of steering wheel angle in the computation or look-up table of torque contribution (*Tweight*) may produce a more accurate result, it is not a necessary feature of the invention that the improved value of steering wheel angle  $\alpha'$  must be used, but rather any one of the measured steering wheel values  $\alpha_1, \alpha_2, \alpha_3, \alpha_4$  could be used, it being understood that using an improved steering wheel angle  $\alpha'$  value may further improve upon the compensation being carried out for steering wheel torque due to a weight imbalance.

Another method for determining a *Torque contribution (Tweight)* signal is now described.

In another embodiment of the invention, an EPAS system 10 for a vehicle is described, in which an EPAS controller 32 is configured to control the amount of assistive torque supplied by an electric motor of the EPAS system 10 based upon factors including consideration of both a weight imbalance present in the steering wheel and optionally any weight imbalance present in the steering mechanism.

The torque contribution (*Tweight*) may be determined by measuring the static, "hands-off" torque  $T$  detected by the torque sensor 20. For example, this measurement is advantageously, but not essentially, taken for several values of the actual steering wheel angle  $\alpha$ , for example, from about 0 to about  $2\pi$  (rad), and storing those values in a look-up table. The stored values can be interpolated in real time against steering wheel angle  $\alpha$ . Optionally the interpolation may be linear, however other suitable interpolation methods may be used for example, a quadratic or other polynomial interpolation, an exponential interpolation or any other suitable mathematical interpolation method may be used. The following table provides an example of a look-up table that may be produced and programmed into the EPAS system 10 for its reference.

$\alpha$	0	$\pi/8$	$2\pi/8$	...
Torque ( <i>Tweight</i> )	$T_1$ [Nm]	$T_2$ [Nm]	$T_3$ [Nm]	...

For every measured value of the steering wheel angle  $\alpha$ , the torque contribution (*Tweight*) to be compensated for is determined. The measurements can be carried out during a calibration process during vehicle production. Additionally, the values in the look-up table can be updated periodically during the vehicles lifetime, for example during servicing.

5

The torque values may be measured under static conditions (otherwise the value will be affected by the acceleration and inertia of the steering wheel), and with "hands-off" the steering wheel (otherwise the value will be affected by the torque applied by the driver). To measure the torque at different angles, it is sufficient (for example) to rotate the steering wheel 12 to a particular angle  $\alpha$ , and record the value of the torque as measured by the torque sensor 20 at that angle  $\alpha$ . Any value different to zero can be attributed to an imbalanced weight (unless there is some stiction in the system, that could hold the sensor twisted, in which case multiple measurements may be needed to average out the error).

15 Preferably, the steering wheel angle used for the look-up table should be the most accurate measurement that is available, for example, the steering wheel angle used in the measurement of torque contribution (*Tweight*) may be one that has been improved by the compensations to be described below. However, it will be understood that a lesser accurate steering wheel angle value may be used during the measurement of torque contribution (*Tweight*), (for example,  $\alpha_1$  or  $\alpha_2$ ) and the resulting approximation of torque contribution (*Tweight*) for that steering wheel angle may still provide a useful set of values of the torque contribution (*Tweight*) that can improve the accuracy of the EPAS system 10. Optionally, but not exclusively, the same source of steering wheel angle measurement used in determining an approximation for the torque contribution (*Tweight*) is used when referencing the look-up table containing the stored values of torque contribution (*Tweight*).

25 The measured determination of torque contribution (*Tweight*) is advantageous because it does not require knowledge of the mechanical parameters of the vehicle. It can also be used to compensate for weights that are not only present on the steering wheel 12, but also for weight imbalances that are present in the steering column. The measurement method can also be used to compensate for distributed rather than point weights within the steering wheel 12 and steering column (if applicable) and for more than one weight (distributed or lumped). In many steering wheels 12 control devices for audio and communications equipment are disposed within the steering wheel 12; the steering wheel 12 itself is often made of different density materials; and

the air bag is not strictly a point weight. As such the weight imbalance is more likely to be a set of distributed weights and not a single point weight. Whereas the calculation approach provides a good and useful approximation of the torque contribution (*Tweight*) that should be compensated for, the measurement method of the present embodiment may be more accurate.

5

However, the measurement method may be more sensitive to stiction (the stiction in the system may directly affect the torque measurements). However, the effect of stiction can at least be partly eliminated with repeated measurement.

10 Whereas the look-up table above contains three measurements of torque contribution (*Tweight*) at three angles, it will be understood that many measurements may be made and made at a desired angle resolution. In other envisaged embodiments, the resolution of measurement of torque contribution (*Tweight*) may or may not be uniform (in other words, torque contribution (*Tweight*) may be measured at every  $\pi/8$  radians for example, or torque contribution (*Tweight*) may be measured at higher resolution intervals within a selected range of steering wheel angle from the straight ahead position, but at lower resolution intervals (ie larger intervals) outside the selected range of steering wheel angle and the resolution may change the further away from the straight ahead or zero position the steering wheel is turned. (This may give greater compensation sensitivity across the most commonly used steering wheel angle range and a lower degree of sensitivity outside of this range, which may yield faster computation).

20

Alternatively, in some embodiments, at angles outside of a "compensation range", torque contribution (*Tweight*) may not be computed, measured or if computed or measured may not be used in a compensation computation. It should also be noted that an EPAS system 10 including a mechanism according to the present invention for computing and/or measuring torque contribution (*Tweight*) that is capable of compensating for *Tweight*, may additionally be programmed to exclude torque contribution (*Tweight*) compensation in certain circumstances.

25

It is envisaged that in other embodiments of EPAS system 10 according to the invention, a combination of analysis of torque contribution (*Tweight*) and measurement of torque contribution (*Tweight*) may be carried out in order to result at an averaged or combined torque contribution (*Tweight*) value. Furthermore, it is envisaged that other analytical approximations and measurement techniques may be deployed to provide a value of torque contribution (*Tweight*) that can be used for its compensation and the specific calculation and measurement methods

30

described herein represent only optional ways of compensating for or cancelling out undesirable effects of weight imbalances.

5      Whichever methods are used to calculate a value of torque contribution (*Tweight*) for a given steering wheel angle  $\alpha$ , once a measurement of torque contribution (*Tweight*) as a function of the steering wheel angle  $\alpha$  is obtained it can be used to compensate for its effects.

10      As referred to above, if compensation is carried out at the Input of the EPAS system 10, torque contribution (*Tweight*) can be compensated for within the EPAS controller 32, by subtracting its value from the torque signal from the sensor:

$$\text{SensorTorqueCorrected} = \text{SensorTorque} - \text{Tweight}$$

15      Torque contribution (*Tweight*) can be compensated at the Output side within the EPAS controller, by subtracting from the motor torque demand  $T_1$  a torque correction (dependent on steering wheel angle) such that it counteracts (e.g. is opposite to) the torque required to move the offset weight. This output side may be done alternatively to the input side correction or may be conducted in addition to the input side correction.

20      The ratio between torque at the electric motor 22 and torque at the steering wheel 12 is not 1, due to the gearing between the two (see gears  $k_1$  and  $k_2$  in Figure 1), therefore the additional torque demand at the electric motor 22 side needs to be appropriately scaled by  $k_1/k_2$  to obtain the correct compensation:

25       $\text{MotorTorqueDemandCorrected} = \text{MotorTorqueDemand} - \text{Tweight} * k_1/k_2$

In other vehicle arrangements the gear configuration may be different to that illustrated and a different scaling factor may therefore be required.

30      In yet another embodiment of the invention, an EPAS system 10 for a vehicle is described, in which an EPAS controller 32 is operable to control the amount of assistive torque supplied by an electric motor 22 of the EPAS system 10 based upon factors including the phasing of one or more joints between mechanically linked components of the steering mechanism. The phase difference of the joints between mechanically linked components can cause undesired non-

linearity in the steering feel. This is because the steering angle (and other variables) as measured by the EPAS system 10 sensors is different from the actual steering wheel angle  $\alpha$ . (This is unless the steering angle measurement is conducted by the EPAS system 10 directly at the steering wheel such that the actual steering wheel angle  $\alpha$  and the measured steering wheel angle  $\alpha_4$  are exactly the same.)

In known EPAS systems, where a direct measurement of the angle of rotation of the steering wheel  $\alpha$  is not taken at the steering wheel 12, the joints 18 in the steering column, between the steering wheel 12 and point of measurement, effect (in other words influence) the accuracy of measurement of steering wheel angle  $\alpha_1, \alpha_2$  etc. Similarly, the steering wheel angular velocity and steering torque measured by the EPAS system 10 may be inaccurate due to the angular phasing introduced by the differently angled joints 17a, 17b between mechanically linked components 15a, 15b, 15c within the steering mechanism 10. These errors within the EPAS system 10 can have an undesirable effect on the steering feel. In this third embodiment of the invention, these additional errors are at least mitigated against or corrected for. This embodiment of EPAS system 10 utilises a series of mathematical functions so that the EPAS controller 32 can correct, adjust or otherwise compensate for any angular phasing between the actual and the measured values of one or more of the following variables: steering wheel angle, steering wheel angular velocity and steering torque.

Referring now to Figure 1, it has been identified that the actual steering wheel angle  $\alpha$  in a vehicle does not necessarily match the shaft angle  $\alpha_3$  where the measurement of steering wheel angle is conducted. This is due, at least in part to the geometry of the non-linear linkage of components 15a, 15b, 15c, 17a, 17b, 18. Considering a single joint 17a (see Figure 3), where two shafts 15a, 15b are disposed at an angle  $\delta_5$  relative to one another, wherein the angle at the input is  $\alpha_5$  and the angle at the output is  $\beta_5$  and wherein  $\omega_a$  and  $\omega_b$  are the angular velocities (in rad/s) of the two shafts 15a, 15b having angles  $\alpha_5$  and  $\beta_5$  respectively. The following relations hold between the angle at its input ( $\alpha_5$  in Figure 3) and the angle at its output ( $\beta_5$  in Figure 3).

$$\frac{\dot{\beta}_5}{\dot{\alpha}_5} = \frac{\omega_b}{\omega_a} = \frac{\cos \delta_5}{1 - \sin^2 \delta_5 \cos^2 \alpha_5}$$

First relationship between input and output angles,  $\alpha_5, \beta_5$  and  $\delta_5$ .

$$\beta_5 = \arctan 2(\sin \alpha_5, \cos \alpha_5, \cos \delta_5)$$

Second relationship between input and output angles,  $\alpha_5$ ,  $\beta_5$  and  $\delta_5$ .

5

$$\alpha_5 = \arctan 2(\sin \beta_5, \frac{\cos \beta_5}{\cos \delta_5})$$

Third relationship between input and output angles,  $\alpha_5$ ,  $\beta_5$  and  $\delta_5$ .

10

The first, second and third relationships can be used to compute, optionally in advance and optionally off-line, an improved or corrected value of an input angle from a measured value of an angle (an output angle). The values can be stored in a look-up table referred to by the EPAS controller 32 and interpolated against steering wheel angle in real-time to calibrate the measured steering wheel angle and/or the steering wheel angle velocity and/or the steering wheel torque. As such the above relationships may not specifically be used by the processor or controller of an EPAS system, but values output from these or similar but optionally more approximate calculations may be provided in a reference table.

15

20

The measured steering wheel angle (for example  $\alpha_3$  in Figure 1) which may be received, as a data signal, by the EPAS controller unit 32, can be corrected by the EPAS controller 32 to compensate for the phase difference imparted by one or all of the non-linear linkages or joints 17a, 17b that are situated between the location at which the steering wheel angle is measured or detected (for example  $\alpha_3$ ) and the steering wheel 12 itself. This correction may be done by applying the first, second and/or third relationships listed above for one or all of the joints 17a, 17b situated between the steering wheel 12 and the measured or detected steering wheel angle ( $\alpha_3$ ) as follows:

25

*CorrectedAngle = function (OriginalAngle)*

$(\alpha_3' = \text{function}(\alpha_3))$

30

$(\alpha_3 = \text{detected value of steering wheel angle, } \alpha_3' = \text{the improved value which is closer to the actual steering wheel angle } \alpha)$

This embodiment of the invention provides an EPAS system 10 that uses more accurate values or improved values of the angle of rotation of the steering wheel. The more accurate data signal or variable values, when used by the EPAS controller unit 32, in real-time, in carrying out its

computations to determine the amount of assistive torque (and any other computations it may be used in) to be supplied by the electric motor 22, may influence or effect the steering feel and result in an improved driving experience.

- 5 An optional aspect of this embodiment of the invention is the correction of steering wheel angular velocity. The measured steering wheel angular velocity parameter is corrected using the same relationships above:

$$\text{CorrectedSteeringVelocity} = \text{function} (\text{MeasuredSteeringVelocity})$$

10

Yet a further optional aspect of this embodiment of the invention is the correction of the actual torque applied by the driver ( $T_d$ ) and the determined torque ( $T$ ), as measured by the torque sensor 20. The torque sensor 20 determined torque ( $T$ ) can be corrected or at least made more accurate to account for some or all of the discrepancy due to, for example, stiffness and/or free-  
15 play using the same approach used for the steering angle and preferably in conjunction with the correction of steering wheel angle. As such, one or all of the first, second and third relationships above can be applied in respect of all of the joints 18 between the steering wheel 12 and the sensor 20 which measures the torque ( $T$ ) applied to the steering wheel 12.

20  $\text{CorrectedTorque} = \text{function} (\text{OriginalTorque})$

It will be understood from the foregoing that the compensation for the presence of one or more joints 18 that imparts an angular phasing of a variable (such as steering wheel angle, steering wheel angular velocity or steering wheel torque) can be carried out in a number of ways. An  
25 example of an analytical approach to compensating for the effect of the phasing caused by one joint has been described, however, it is envisaged that many and various other ways for approximating or determining the effect of the joints phasing and correcting for the same will be suitable for carrying out the invention. For example, any of the trigonometric functions mentioned in the above equations may be approximated by a fixed value or a series expansion  
30 may be computed to determine the value (such as a Taylor or Euler Series Expansion); further optionally, predefined values for each or any term in the above relationships may be listed in a look-up table (if appropriate) to be referenced during the computation of a more accurate input variable from the detected or measured output variable. Additionally, or alternatively, or in combination, any of the trigonometric functions may be substituted in order to simplify the



computation (and thereby optionally reduce the processing time needed in order to compute the compensation). It is envisaged that any of the trigonometric functions listed in the above equations may be computed by using an expansion series such as a Taylor Expansion Series or if appropriate an Euler Expansion Series and/or predetermined and listed in a reference or  
5 look-up table. The values, if provided in a look-up table may be linearly interpolated, quadratically interpolated, exponentially interpolated or interpolated using any other suitable mathematical method that would provide a suitable approximate value for the trigonometric function value falling between two listed values.

10 Furthermore it will be understood that the order in which certain terms are computed may be adjusted in other embodiments of the invention and that a combination of calculation and/or referencing and/or approximation may be used for any or all of the relationships adopted to improve the accuracy of the detected variable.

15 A further embodiment of the invention is now described in which a compensation for the influence or effect of the steering wheel torque sensor 20, (which typically comprises a torsion bar, in an in-line measurement, but may, in alternative embodiments be a reactive torque sensor which causes drag) is made. This compensation for the angle of the torsion bar of the torque sensor 20 may be required because the torque sensor input angle  $\alpha_3$  and the torque sensor  
20 output angle  $\alpha_2$  (see Figure 1) do not necessarily match. This mis-match, phase difference or error between torque sensor input angle  $\alpha_3$  and the torque sensor output angle  $\alpha_2$  is considered to be due to the deflection across the torsion sensor 20 due to the low-stiffness of the torsion sensor 20 (torsion bar) in the in-line torque sensor 20. A torque T in the torque sensor 20 causes a displacement  $\Delta\alpha$ .

25 The steering angle measured by the EPAS system 10 may therefore be different from the actual steering wheel angle  $\alpha$ . (This is unless the steering wheel angle is measured before the position of the torque sensor 20. If the steering wheel angle is measured directly at the steering wheel  $\alpha_4$  or further in the steering mechanism downstream of the steering wheel, for example at optional  
30 sensor location  $\alpha_3$ , but before (upstream of) the position of the torque sensor 20, then the measurement of steering wheel angle is not affected by the torque sensor 20.)

If the steering wheel angle of the EPAS system 10 is measured at or after the position of the torque sensor 20, then the value of steering wheel angle received by the EPAS controller unit

32 can be corrected by the EPAS controller unit 32, to compensate for any inaccuracy imparted by the torque sensor 20 (for example when the torque sensor 20 is a torsion bar, the displacement  $\Delta\alpha$ ), to obtain a more accurate value of the actual steering wheel angle  $\alpha$ .

- 5 The angular displacement  $\Delta\alpha$  across the torque sensor 20 is usually a known signal of an EPAS system 10, (this is because it is used to compute the torque T itself, optionally, by the following equation:  $T = \Delta\alpha \times S$ , where S is the known stiffness of the torsion bar). The angle measured at or after the position of the torque sensor 20 can therefore be corrected using:

$$\text{CorrectedAngle} = \text{OriginalAngle} - \Delta\alpha$$

10

It will be understood that the various embodiments of the invention described can be implemented together, separately or in a variety of combinations to create an EPAS system that is beneficially more accurate in the assistive torque it applies.

15

CLAIMS:

5 1. A vehicle comprising an electric power assisted steering (EPAS) system, wherein the EPAS system is configured to use at least an approximation of a torque contribution ( $T_{weight}$ ) to the steering wheel torque caused by the presence of one or more weights disposed in the steering wheel in an off-centre position to compensate for that torque contribution ( $T_{weight}$ ) by computing a corrected value of steering wheel torque from a detected value of steering wheel torque and/or to compensate for that torque contribution ( $T_{weight}$ ) by computing a corrected value of assistive motor torque.

10

2. A vehicle according to claim 1 wherein the corrected value of steering wheel torque is computed by the EPAS system by subtracting the at least an approximation of the torque contribution ( $T_{weight}$ ) from the detected value of steering wheel torque as follows:  
 $SensorTorqueCorrected = SensorTorque - T_{weight}$ .

15

3. A vehicle according to claim 1 or 2 wherein the corrected derived assistive motor torque is computed by the EPAS system by subtracting a scaled value of the at least an approximation of the torque contribution ( $T_{weight}$ ) from a derived value of assistive motor torque ( $T_1$ ) as follows:

20

$$MotorTorqueDemandCorrected = MotorTorqueDemand (T_1) - T_{weight} * k_1 / k_2.$$

4. A vehicle according to any preceding claim wherein the at least an approximation of the torque contribution ( $T_{weight}$ ) used by the EPAS system is calculated or is referenced from a look-up table of measured values.

25

5. A vehicle comprising an electric power assisted steering (EPAS) system, wherein the EPAS system is capable of receiving a detected value of steering wheel torque and wherein the EPAS system is configured to improve the accuracy of the detected value of steering wheel torque by compensating for a weight imbalance present in the steering wheel or by compensating for a weight imbalance present in the steering wheel and steering wheel column.

30

6. A vehicle according to claim 5 wherein the EPAS system is configured to derive an assistive motor torque ( $T_1$ ) to be supplied by a motor of the EPAS system and wherein the

EPAS system is configured to compensate for the influence of a weight imbalance present in the steering wheel by adjusting the derived assistive motor torque ( $T_1$ ) using a torque correction that is dependent upon steering wheel angle ( $\alpha$ ).

- 5 7. A vehicle according to any preceding claim wherein the EPAS system is configured to compute the torque contribution ( $T_{weight}$ ) by: approximating the weight imbalance as one or more point masses and/or approximating the angular position of the mass and/or approximating the radial position of the mass and/or approximating the angular position of the steering wheel relative to a horizontal plane.

10

8. A vehicle according to claim 7 wherein the EPAS system is configured to compute the torque contribution ( $T_{weight}$ ) as follows:

$$T_{weight}[Nm] = W[kg] \cdot R[m] \cdot g \cdot \sin(\alpha + \beta),$$

15

wherein, the weight imbalance is treated as a single point mass ( $W$ ), disposed at an angle ( $\beta$ ) from the straight ahead position, at a radius ( $R$ ) from the centre of the steering wheel, for a steering wheel angle of rotation ( $\alpha$ ) and factor ( $g$ ) is the acceleration due to gravity.

20

9. A vehicle according to claim 8 wherein the factor ( $g$ ) is taken to be between  $9 \text{ m/s}^2$  to  $10 \text{ m/s}^2$  and/or taken to be  $9.81 \text{ m/s}^2$ .

25

10. A vehicle according to claim 8 or 9 wherein the computation further includes a term to account for the steering wheel being positioned at an angle ( $\delta$ ) relative to a notional horizontal plane, the computation at least approximating *Torque contribution* ( $T_{weight}$ ) as follows:

$$T_{weight}[Nm] = W[kg] \cdot R[m] \cdot g \cdot \sin(\alpha + \beta) \cdot \sin(\delta)$$

30

11. A vehicle according to claim 1 to 6 wherein the EPAS system is configured to compensate for the torque contribution ( $T_{weight}$ ) of any weight imbalance present in the steering wheel by computing a corrected value of steering wheel torque from a detected value of steering wheel torque and/or is configured to compensate for that torque contribution ( $T_{weight}$ ) by computing a corrected value of assistive motor torque ( $T_1$ ), and wherein the EPAS system is configured to refer to a look-up table comprising a series of values of torque contribution ( $T_{weight}$ ), each torque contribution for a given angle of rotation of the steering wheel.

- 5 12. A vehicle according to claim 11 wherein the EPAS controller is configured to compensate for the torque contribution (*Tweight*) by conducting a real-time interpolation of the torque contribution (*Tweight*) from the look-up table against the angle of rotation of the steering wheel.
13. A vehicle according to claim 12 wherein the interpolation is any one of linear, quadratic, other polynomial or exponential.
- 10 14. A vehicle according to claim 12 or 13 wherein the values of torque contribution (*Tweight*) contained in the look-up table are measured under static conditions.
15. A vehicle according to any preceding claim wherein the angle of rotation of the steering wheel ( $\alpha$ ) is a detected variable and the EPAS system:
- 15 (i) uses the detected angle of rotation of the steering wheel in a computation of the torque contribution (*Tweight*) or uses the detected angle of rotation of the steering wheel in a look-up table referencing of the torque contribution (*Tweight*); or
- 20 (ii) improves the accuracy of the detected angle of rotation of the steering wheel by compensating for a phasing of the joints between any two linked components of the steering mechanism and uses the improved value of steering wheel angle in a computation of the torque contribution (*Tweight*) or in referencing a look-up table of the torque contribution (*Tweight*); or
- 25 (iii) improves the accuracy of the detected angle of rotation of the steering wheel by compensating for the effect on steering wheel angle of deflection across a torque sensor (20) due to the low-stiffness of the torque sensor and uses the improved value of steering wheel angle ( $\alpha$ ) in a computation of the torque contribution (*Tweight*) or in referencing a look-up table of the torque contribution (*Tweight*).
- 30 16. A vehicle according to claim 15 wherein a sensor for detecting the angle of rotation of the steering wheel is disposed within the steering mechanism and is not directly connected to the steering wheel.

17. A vehicle according to any preceding claim wherein the EPAS system is further capable of receiving a second detected variable value or deriving a variable value from a second detected variable value and is configured to improve the accuracy of that second detected and/or derived variable value to at least partially eliminate any discrepancy between the actual variable value and the second detected or derived variable value and wherein the second detected or derived variable is one of: steering wheel angle, steering wheel angular velocity and motor angle.

5

18. A vehicle according to claim 17 wherein the EPAS system is configured to improve the accuracy of the second detected or derived variable value by compensating for any one or more of:

10

(i) an angular phasing of joints between any two linked components of the steering mechanism; and

(ii) the effect on steering wheel angle of the deflection across the torque sensor (20) at least substantially due to the low-stiffness of that torque sensor.

15

19. A vehicle according to claim 18 wherein the EPAS system is configured to compensate for the effect of angular phasing of the joints between two linked components of the steering mechanism using any one or more of the following relationships:

20

$$\frac{\dot{\beta}_5}{\dot{\alpha}_5} = \frac{\omega_b}{\omega_a} = \frac{\cos \delta_5}{1 - \sin^2 \delta_5 \cos^2 \alpha_5}$$

$$\beta_5 = \arctan 2(\sin \alpha_5, \cos \alpha_5, \cos \delta_5)$$

25

$$\alpha_5 = \arctan 2(\sin \beta_5, \frac{\cos \beta_5}{\cos \delta_5})$$

20. A vehicle according to any of claims 17 to 19 wherein the second detected variable value is the angle of rotation of the steering wheel, and wherein the EPAS system is configured to compensate for the influence of the steering wheel torque sensor (20) to improve the accuracy of the angle of rotation of the steering wheel used by the EPAS system to compute the amount of assistive torque supplied by the motor by determining and subtracting the displacement angle ( $\Delta\alpha$ ) from the detected angle of rotation of the steering wheel.

30

21. A vehicle comprising an electric power assisted steering (EPAS) system substantially as described herein with reference to and/or as illustrated by the accompanying drawings.
22. An electric power assisted steering (EPAS) system for use in a vehicle according to any preceding claim.
23. A controller for use in an electric power assist steering system according to claim 22, the controller configured to determine or use at least an approximation of a torque contribution (*Tweight*) to the steering wheel torque caused by the presence of one or more weights disposed in the steering wheel in an off-centre position to compensate for that torque contribution (*Tweight*) by computing a corrected value of steering wheel torque from a detected value of steering wheel torque and/or to compensate for that torque contribution (*Tweight*) by computing a corrected value of assistive motor torque.
24. A method of assisting the steering of a vehicle, the method comprising:
- (i) providing an electronic power assisted steering (EPAS) system having an EPAS control unit and a steering wheel torque sensor;
  - (ii) configuring the EPAS control unit to use at least an approximation of a torque contribution (*Tweight*), caused by the presence of one or more weights disposed within the steering wheel in an off-centre position; and
  - (iii) configuring the EPAS control unit to compute a corrected value of steering wheel torque using said torque contribution (*Tweight*); and/or
  - (iv) configuring the EPAS control unit to compute a corrected value of assistive motor torque using said torque contribution (*Tweight*).
25. A method according to claim 24 wherein the corrected value of steering wheel torque is computed by subtracting said torque contribution (*Tweight*) from the detected value of steering wheel torque as follows:

$$\text{SensorTorqueCorrected} = \text{SensorTorque} - \text{Tweight}.$$

26. A method according to claim 23 or 24 wherein the corrected derived assistive motor torque is computed by subtracting a scaled value of said torque contribution (*Tweight*) from a derived value of assistive motor torque ( $T_1$ ) as follows:

5

$$\text{MotorTorqueDemandCorrected} = \text{MotorTorqueDemand} (T_1) - \text{Tweight} * k_1 / k_2.$$

27. A method according to any claim 24 to 26 further comprising the step of determining the torque contribution (*Tweight*) by a computation that comprises: approximating the weight imbalance as one or more point masses and/or approximating the angular position of the mass and/or approximating the radial position of the mass and/or approximating the angular position of the steering wheel relative to a horizontal plane.

10

28. A method according to claim 27 wherein the step of determining the torque contribution (*Tweight*) comprises the following calculation:

15

$$\text{Tweight}[Nm] = W[kg] \cdot R[m] \cdot g \cdot \sin(\alpha + \beta),$$

wherein, the weight imbalance is treated as a single point mass (*W*), disposed at an angle ( $\beta$ ) from the straight ahead position, at a radius (*R*) from the centre of the steering wheel, the steering wheel having an angle of rotation ( $\alpha$ ) and factor (*g*) is the acceleration due to gravity.

20

29. A method according to claim 28 wherein, the factor (*g*) to account for acceleration due to gravity is taken to be between 9 m/s<sup>2</sup> and 10 m/s<sup>2</sup> and/or taken to be 9.81m/s<sup>2</sup>.

25

30. A method according to claim 28 or 29 wherein the calculation further includes a term to account for the steering wheel being positioned at an angle ( $\delta$ ) relative to a notional horizontal plane, the computation at least approximating *Torque contribution* (*Tweight*) as follows:

30

$$\text{Tweight}[Nm] = W[kg] \cdot R[m] \cdot g \cdot \sin(\alpha + \beta) \cdot \sin(\delta)$$



31. A method according to any claim 24 to 26 further comprising the step of determining the torque contribution by: referring to a look-up table comprising a series of values of torque contribution (*Tweight*), each torque contribution for a given angle of rotation of the steering wheel, and the method including controlling the amount of assistive torque applied to the electric motor by conducting a real-time interpolation of the torque contribution (*Tweight*) from the look-up table against the angle of rotation of the steering wheel.

32. A method substantially as described herein with reference to and/or as illustrated by the accompanying drawings.

33. A program for a computer for use in an EPAS system of a vehicle, the program containing one or more algorithms for carrying out the method of any claim 24 to 31 such that when running, the program is configured to at least approximately determine a torque contribution (*Tweight*) or to reference an at least approximate torque contribution stored in a look-up table, caused by the presence of one or more weights disposed within the steering wheel in an off-centre position.

34. A program according to claim 33 wherein the program is capable of receiving a detected value of steering wheel torque and is configured to improve the accuracy of the detected value of steering wheel torque by subtracting the determined or referenced torque contribution (*Tweight*) from the detected value of steering wheel torque as follows:

$$\text{SensorTorqueCorrected} = \text{SensorTorque} - \text{Tweight}.$$

35. A program according to claim 33 or 34 wherein a corrected derived assistive motor torque is computed by subtracting a scaled value of the determined or referenced torque contribution (*Tweight*) from a derived value of assistive motor torque ( $T_1$ ) as follows:

$$\text{MotorTorqueDemandCorrected} = \text{MotorTorqueDemand} (T_1) - \text{Tweight} * k_1/k_2.$$

36. An electric power assisted steering (EPAS) system for a vehicle, the system being configured to use at least an approximation of a torque contribution (*Tweight*) to the steering wheel torque caused by the presence of one or more weights disposed in the steering wheel in an off-centre position to compensate for that torque contribution

(*Tweight*) by computing a corrected value of steering wheel torque from a detected value of steering wheel torque and/or to compensate for that torque contribution (*Tweight*) by computing a corrected value of assistive motor torque.

- 5 37. A system, a program, a vehicle or a method constructed and/or arranged substantially as described herein with reference to one or more of the accompanying drawings.

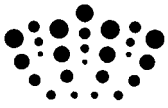

**Application No:** GB1219433.8  
**Claims searched:** 1-20, 22-31, 33-36

**Examiner:** Mark Thwaites  
**Date of search:** 22 February 2013

**Patents Act 1977: Search Report under Section 17**

**Documents considered to be relevant:**

Category	Relevant to claims	Identity of document and passage or figure of particular relevance
A	-	EP1958850 A1 (HONDA)

**Categories:**

X	Document indicating lack of novelty or inventive step	A	Document indicating technological background and/or state of the art.
Y	Document indicating lack of inventive step if combined with one or more other documents of same category.	P	Document published on or after the declared priority date but before the filing date of this invention.
&	Member of the same patent family	E	Patent document published on or after, but with priority date earlier than, the filing date of this application.

**Field of Search:**

Search of GB, EP, WO & US patent documents classified in the following areas of the UKC<sup>X</sup>:

--

Worldwide search of patent documents classified in the following areas of the IPC

B62D
------

The following online and other databases have been used in the preparation of this search report

EPODOC, WPI, TXTE
-------------------

**International Classification:**

Subclass	Subgroup	Valid From
B62D	0005/04	01/01/2006