



US00D385080S

United States Patent [19]

[11] Patent Number: Des. 385,080

Schueneman et al.

[45] Date of Patent: **Oct. 14, 1997

[54] ROLL SUPPORT

5,123,547 6/1992 Koch 211/59.4
5,161,703 11/1992 Patton 211/59.4

[75] Inventors: **Herbert H. Schueneman**, Monterey, Calif.; **Robb A. Warren**, Appleton, Wis.; **Richard M. Butler**, Menasha, Wis.; **Cary M. Dean**, Milwaukee, Wis.

OTHER PUBLICATIONS

Keys-Fiber Company, Blueprints, 1979.
Henry Molded Products, Blueprint 12" Stakker, Apr. 6, 1990.
Prior Art Roll Support manufactured and sold by Fiber Packaging Corp., Date 1983.
Second Prior Art Roll Support manufactured and sold by Fiber Packaging Corp. of Jasper, TX in 1983.

[73] Assignee: **Great Northern Corporation**, Appleton, Wis.

[**] Term: 14 Years

Primary Examiner—Brian N. Vinson
Assistant Examiner—Robin V. Taylor
Attorney, Agent, or Firm—Andrus, Scales, Starke & Sawall

[21] Appl. No.: 59,213

[22] Filed: Sep. 5, 1996

Related U.S. Application Data

[62] Division of Ser. No. 41,230, Jul. 10, 1995.

[51] LOC (6) CL 09-08

[52] U.S. Cl. D34/38

[58] Field of Search D34/28, 38; 108/51.1, 108/51.3, 55.3, 56.1, 57.1; 248/346.02, 346.03, 346.11; 206/391; 211/59.4

[57] CLAIM

The ornamental design for the roll support, as shown and described.

DESCRIPTION

FIG. 1 is an isometric view of the roll support of the present invention;
FIG. 2 is a top plan view of a portion of the roll support of FIG. 1;
FIG. 3 is a side elevational view of a portion of the roll support of FIG. 1;
FIG. 4 is an end view of the roll support of FIG. 1, the other end being identical;
FIG. 5 is a cross sectional view of a portion of the roll support of FIG. 1 taken along line 5—5; and,
FIG. 6 is a cross sectional view of the roll support of FIG. 1 taken along line 6—6.
The roll support is shown broken away in FIGS. 1-3 to indicate indeterminate length and the roll support design repeats longitudinally as indicated.

[56] References Cited

U.S. PATENT DOCUMENTS

D. 256,346	8/1980	Annis	D34/38
2,838,173	6/1958	Emery	206/65
2,990,951	7/1961	Fallert	206/65
3,590,752	7/1971	DePew	108/53
3,708,084	1/1973	Bixler et al.	217/26.5
3,753,407	8/1973	Tilseth	108/53
4,195,732	4/1980	Bell	206/391
4,385,091	5/1983	Roelchen	428/134
4,435,463	3/1984	Roelchen	428/158
4,796,540	1/1989	Pelfrey	108/55.3
4,832,196	5/1989	Butler	206/391
4,901,870	2/1990	Wright et al.	211/59.4
5,080,314	1/1992	Moyer et al.	248/346

1 Claim, 2 Drawing Sheets

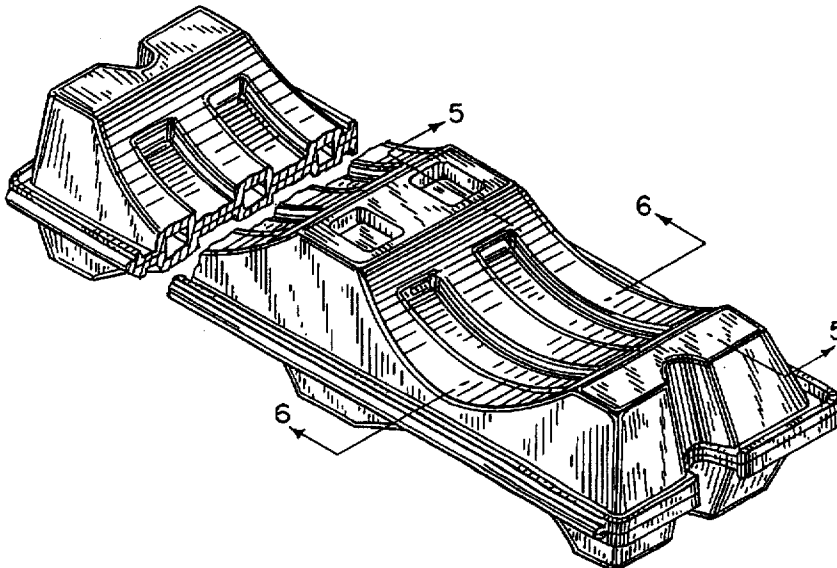

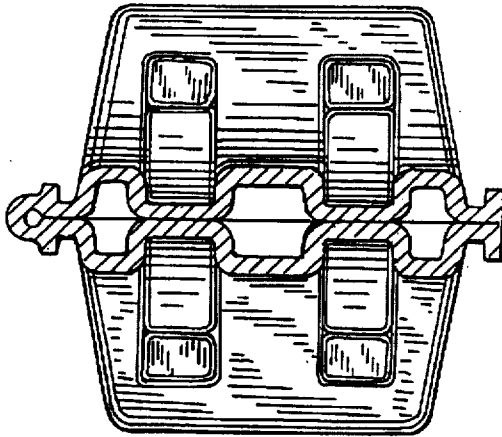
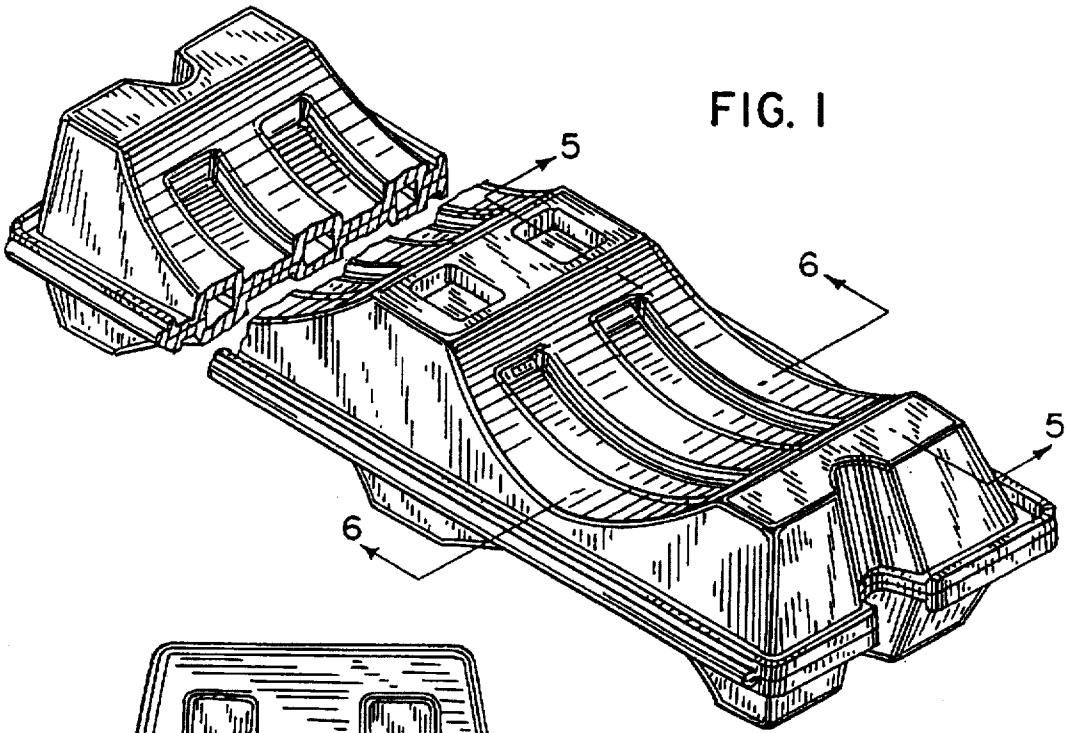

FIG. 6

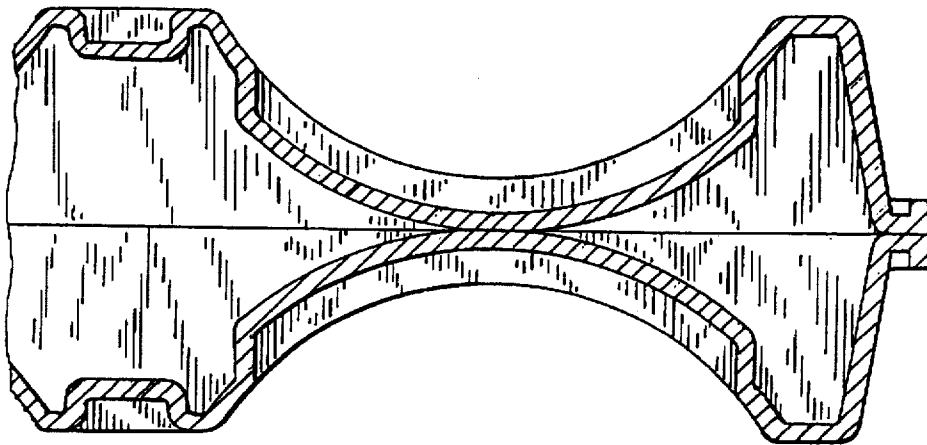

FIG. 5

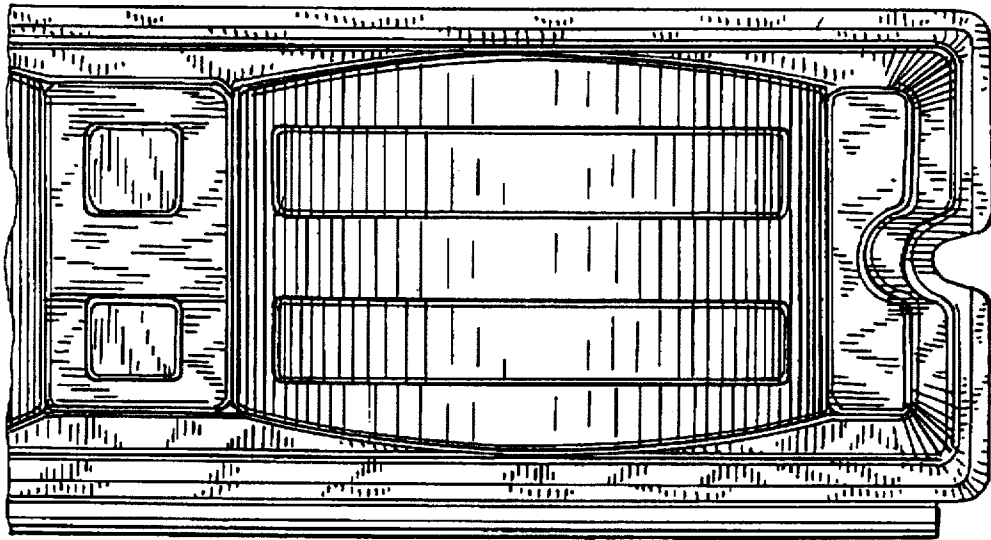

FIG. 2

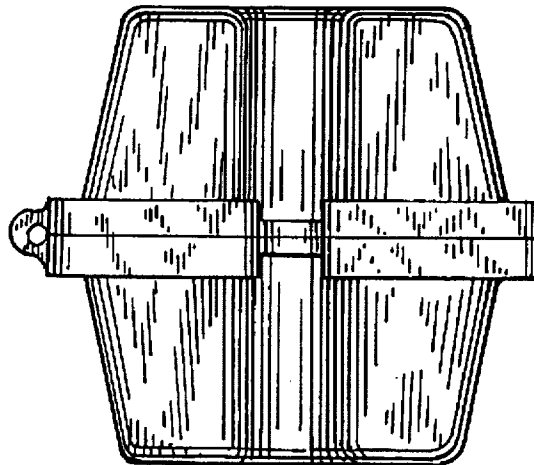

FIG. 4

FIG. 3

