

(No Model.)

W. CANNELL.
APPARATUS FOR ELECTRIC BRANDING.

No. 445,648.

Patented Feb. 3, 1891.

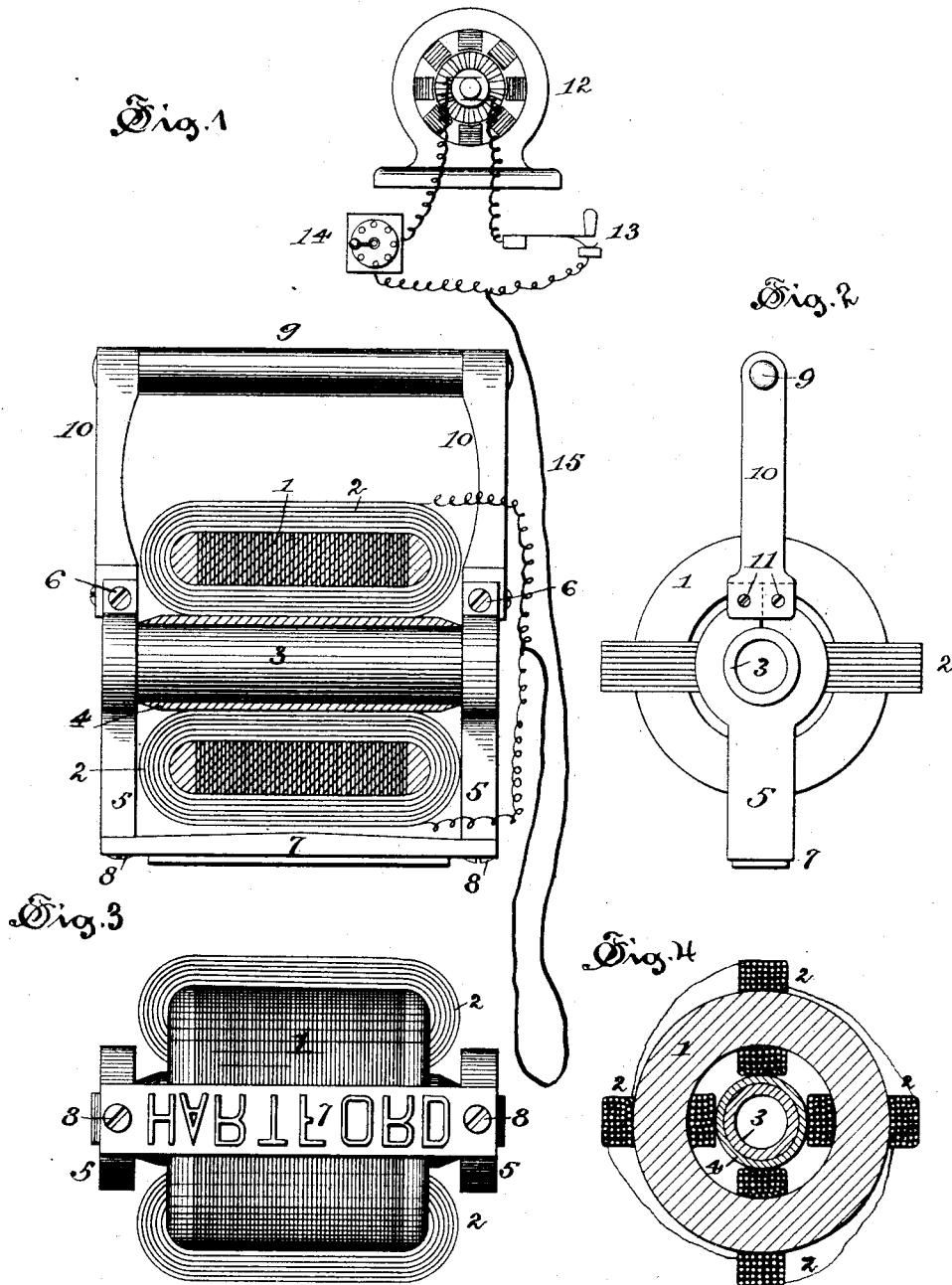

Witnesses:
Harry R. Williams.
Albert H. Walker

Inventor,
William Cannell,
By Willard Eddy,
Atty.

UNITED STATES PATENT OFFICE.

WILLIAM CANNELL, OF HARTFORD, CONNECTICUT.

APPARATUS FOR ELECTRIC BRANDING.

SPECIFICATION forming part of Letters Patent No. 445,648, dated February 3, 1891.

Application filed April 8, 1890. Serial No. 347,085. (No model.)

To all whom it may concern:

Be it known that I, WILLIAM CANNELL, of the city and county of Hartford, Connecticut, have invented certain new and useful Improvements in Apparatus for Electric Branding, which improvements are described in the following specification and are illustrated by the accompanying drawings.

The invention, relating in general to the art of branding and involving the use of a hot brand, consists, particularly, in the method and mechanism whereby the brand is heated electrically.

The best manner in which I have contemplated applying the principle of my invention is illustrated by said drawings, in which—

Figure 1 represents apparatus for electric branding including a portable electric brander constructed in accordance with my invention and shown in side elevation, with parts in section, and also an electric generator, a rheostat, and a switch with connections. Fig. 2 is an end view of said brander. Fig. 3 is a face or bottom view of the same. Fig. 4 is a central vertical cross-section of a part of the brander.

The brander which is depicted in these views comprises a peculiarly constructed electrical transformer and a branding plate or brand which constitutes a portion of the secondary circuit of such transformer. The core 1 of the transformer being of laminated structure and cylindrical form consists of numerous annular plates of sheet-iron placed side by side and insulated from each other. The wire coils 2 of the primary circuit are wound lengthwise of the core in and out, as shown, and are preferably connected in series with each other and with the generator, rheostat, and switch, which are hereinafter described. The secondary circuit of the transformer consists of tube 3, side clamps 5, and branding-plate 7. Tube 3, being concentric with core 1 and supporting the same, is made of copper or other highly-conductive material, and is separated from coils 2 by the insulating-cover 4. This arrangement is plainly seen in Fig. 4, which is a cross-section of core 1, coils 2, tube 3, and the insulating-cover 4. The opposite end portions of tube 3 being un-insulated enter holes which are made therefor in the two side pieces 5, respectively.

These side pieces, being of like dimensions and made of copper or other highly-conductive material, are set in parallel positions on tube 3 and are brought into ample contact therewith by means of clamping-screws 6.

The branding-plate or brand 7 is preferably made of iron, nickel, or other metal of high resistance and is fastened upon side pieces 5 in electrical contact therewith by screws 8. The cross-sectional area of plate 7 is small, and its electrical resistance relative to that of tube 3 and side pieces 5 is great. It is immaterial, however, whether the increased resistance of plate 7 is secured by its diminished size relative to the rest of the secondary circuit or by the high resistance of the material of which that plate is formed, or by both means together. Raised letters or any other desired characters in relief are formed upon the face of plate 7, as seen in Fig. 3.

For the purpose of regulating the distribution of heat in plate 7 and of imparting a uniform temperature to such letters or other characters in relief thereon that plate is made thickest in the middle, as seen in Fig. 1, and its cross-sectional area is made to diminish gradually from the middle to the ends of the plate. Without this precaution the middle part of the plate would be heated most and soonest and the letters would be unequally burned into the branded surface.

The described brander is provided with a handle 9, rigidly attached by means of two wooden or other insulating side pieces 10, which are fastened to side clamps 5 by screws 11.

The numeral 12 denotes an electric generator of the alternating type provided with a switch 13 and a choking coil or rheostat 14, which are connected with coils 2, in the described manner, through cable 15. All other particulars or construction of this brander will sufficiently appear from the drawings and from the process of electric branding, which remains to be described.

In electric branding by the use of the described apparatus, the duration and the strength of the current, which is admitted from generator 12 to primary coils 2, are regulated by manipulating switch 13 and rheostat 14. The induced current in the second-

ary circuit including plate 7 is therefore indirectly regulated in the same manner. The passage of the secondary current through plate 7 for a short time brings that plate, including the raised characters thereon, to a branding temperature. By continued current the same temperature is maintained as long as desired. By manual pressure upon handle 9 the brand while so heated is applied in the ordinary manner to any desired brandable article until the desired charring or branding effect is produced.

Such being the nature of my invention, I claim—

1. In an electric brander, a high-resistance branding-plate or brand, being largest in the middle and of gradually-diminishing cross-section toward the opposite ends thereof and having raised letters or other characters in relief thereon, substantially as and for the purpose specified.

2. In an electric brander, an electric transformer having as a portion of its secondary circuit a branding-plate whose cross-section, being greatest at the middle of the plate, diminishes gradually toward the opposite ends of the plate, substantially as and for the purpose specified.

3. A magnetic core and a high-resistance primary coil thereon, in combination with a secondary circuit having a general low resistance and including a branding-plate or brand which has a predetermined variable cross-sectional area, and is provided with raised letters or other characters in relief, substantially as and for the purpose specified.

4. Apparatus for electric branding employing electric current as the heating agent, and consisting of an alternator supplying current of high electro-motive force, in combination with a switch and rheostat and a transformer whose secondary circuit carrying a large volume of electric current includes a branding-plate or brand which has a variable cross-sectional area, and is adapted to be heated uniformly and simultaneously from end to end by that volume of current, substantially as and for the purpose specified.

In testimony whereof I hereunto set my name in the presence of two witnesses.

WILLIAM CANNELL.

Witnesses:

WILLARD EDDY,
RICHARD H. MATHER.