

Nov. 17, 1953

E. S. PERSSON
FRAMING OF METAL PROFILES, PARTICULARLY FOR
MOVABLE AND GLAZED WINDOWS AND DOORS
Filed Nov. 15, 1948

2,659,463

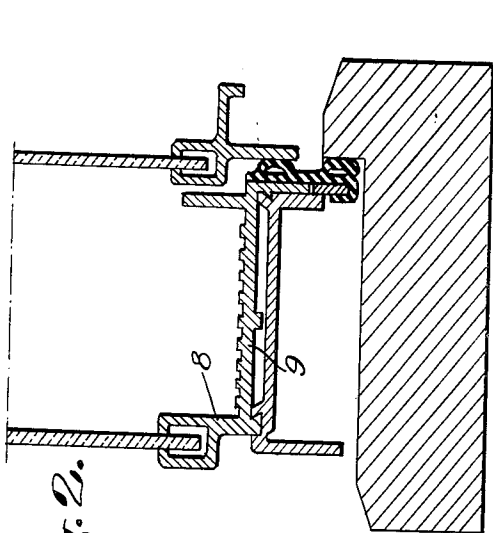

Fig. 2.

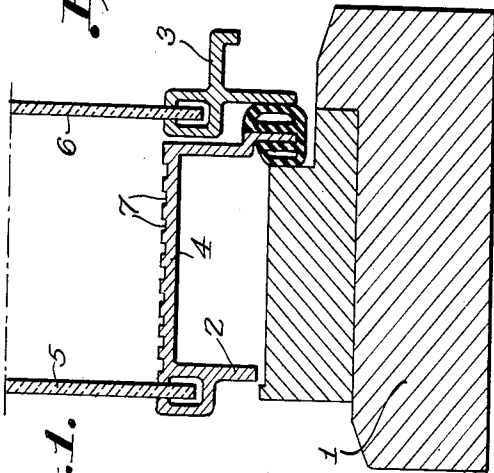

Fig. 1.

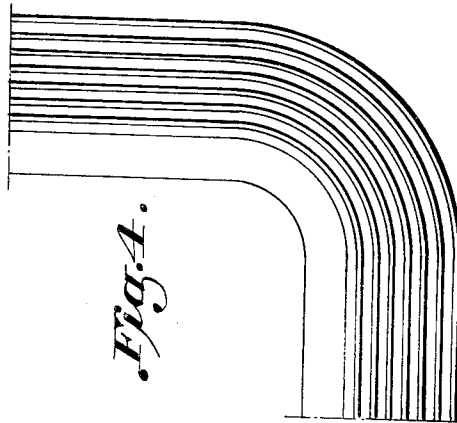

Fig. 4.

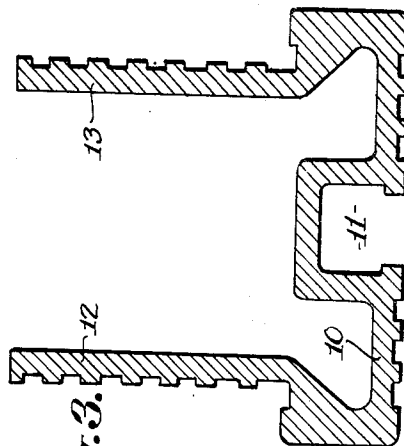

Fig. 3.

Inventor,
ERIC S. PERSSON.
By: Young, Emery & Thompson
Attys.

UNITED STATES PATENT OFFICE

2,659,463

FRAMING OF METAL PROFILES, PARTICULARLY FOR MOVABLE AND GLAZED WINDOWS AND DOORS

Eric Sigfrid Persson, Malmö, Sweden

Application November 15, 1948, Serial No. 60,128

Claims priority, application Sweden, June 29, 1948

4 Claims. (Cl. 189—75)

1

This invention relates to windows and doors, and more particularly has reference to the style and rail framing of window sashes and doors.

In the prior art window sashes, doors and the like, one or more surfaces on the metal framing are visible and exposed to atmospheric influence and therefore usually are provided with a resisting coating with a neat appearance. However, it has been found that treated or painted surfaces are liable to be scratched very easily which on smooth surfaces is unsightly. The scratches form disturbing spots which are not desired. In light openings in window sashes and doors with metal framing, the usually smooth surfaces of the framing cause irritating light reflections.

The object of this invention is to make metal framing for window sashes and doors in which the said disadvantages may be reduced or completely eliminated.

Another object of this invention is to make the frame members, adjacent the glass panes, of metal profiled strips with rifled surfaces.

Another feature of framings according to the invention is that they are made of pressed or rolled metal strips having desired profiles. Such metal strips may also be used in sashes and frames with one or more rounded corners with unbroken contours for windows and doors. Hitherto known profiled strips for such purposes were treated or painted after the bending of the profiled strips to their desired form, as their surfaces otherwise would be damaged by the friction between the bending tools and the material. For the production of framings of said kind, therefore, a considerable space is required for treating or painting apparatus, storing and conveying equipment.

Another object of the present invention is first to make framings with a resisting and beautiful surface as above described, and second, to reduce the cost of production. For these purposes, the surfaces of the framing are rifled, especially on such surfaces which are exposed to frictional engagement with the bending tools during the bending. Then the lower rifled surfaces may be treated or painted before the bending without being damaged, as only the higher surfaces adjacent the rifling grooves engage the tools.

Another object is to avoid the reflections from the large, plane surfaces of the metal profiled strips forming the framing by providing them with grooves.

Other features, objects and advantages of the present invention will appear from the following

2

description, wherein reference is made to the accompanying sheet of drawing wherein:

Figures 1 and 2 are sectional views through the frame and sashes in a window with sashes made of metal profiled strips;

Fig. 3 is a sectional view of a metal door frame and

Fig. 4 is a front view of part of a bent profiled strip according to Fig. 3.

Fig. 1 is a sectional view through the frame 1 in a window with two coupled sashes 2, 3 formed of metal profiled strips. The part 4 of the metal frame of the sash 2 which lies between the two window panes 5, 6 tends to reflect sunshine and, if it was smooth, the reflections would be very irritating. By providing this surface with small grooves 7, the irritating effect of the reflections is reduced and at the same time, the surface has a more appealing appearance which may be further enhanced by painting the grooves.

In Fig. 2 a sectional view is shown similar to the section in Fig. 1. The part 9 of the profiled strip 8 is made with the large, visible surface rifled.

Fig. 3 is a sectional view of a metal profiled frame for doors in which the advantages of the invention are employed. The profiled strip has a U-shaped section with a channel 11 for a pane. The shown profiled strip is intended to be combined with another profile which serves as a stiffener between the legs 12, 13. All the out-turned surfaces will be visible in the door and for that reason they are rifled to eliminate the reflections. However, the profiled strip has also been shaped with the consideration that it has to be bent to form a frame with rounded corners and unbroken lines in at least one corner. It will be bent around a line parallel with the bottom of the U-section and with the legs turned outwards. For the bending, known tools are used which are moved in relation to the profiled strip and may scratch the surfaces of the profiled strip. If these surfaces were quite plane, a paint coating applied thereon would be so damaged that the treatment would have to be repeated after the bending. By making the surface rifled, it is possible to paint or otherwise treat the lower surfaces in the grooves before bending the profiled strip without having them damaged by the bending process. Thus, in production, it is possible to work continually with treating and/or painting of straight lengths of the profiled strips, which thereupon are bent and further processed. The production in this way will be more rapid and cheaper. With profiled strips shaped accord-

3

ing to Figs. 3 and 4, a very neat appearance is achieved especially in entrances where previous large smooth surfaces have reflected sunshine and daylight and all unevenness of the surfaces have been accentuated in a very non-appealing manner. To improve the appearance of the large surfaces, lines are ruled in the surfaces (Fig. 4). The higher surfaces between the grooves may have the same color as the material or some other color as well as the lower surface parts. The term treatment of a surface here also involves such a production of the profiled strips that the surface is acceptable without any special subsequent treatment, which process can be used in all cases where a sufficiently durable surface is obtained. The figures of the drawing show diagrammatically how the invention can be applied and how the shape of the metal strips may be modified. The profiled strips may have grooves only on one side or on several sides and of course also on the inner sides. It may be suitable to provide grooves only on part of a surface, if just this part is to be visible in the finished framing. The depth of the grooves as well as their width may be arranged according to the actual demand. If the lower surfaces are intended to be treated without painting, the depth may be smaller than if they have to be painted.

The invention involves several other advantages among which has to be mentioned that the painting in the lower surfaces in the grooves is protected against damage caused by the cleaning or dusting of the framing and the glasses. Venetian blinds and other similar arrangements in windows and doors may rub the painted or the treated side surfaces of the usual frames or sashes, but with framings according to the present invention, this disadvantage is avoided.

For transportation of products of this kind made according to the prior art, it has been necessary to pack them very carefully in order to protect them against scratches. With products according to the present invention, it is possible to reduce considerably the work of packing and the material used therefor without risk.

It is to be understood that the foregoing detailed description is merely given by way of il-

4

lustration and many variations may be made therein without departing from the spirit of my invention.

Having described my invention what I desire to secure by Letters Patent is:

1. A metal frame for windows and doors comprising style and rail members, each of said members having front and rear surfaces and a surface extending between the front and rear surfaces and cooperating with the corresponding surfaces of the other members to form an inner peripheral wall defining a light opening, said inner peripheral wall having a glass receiving channel associated therewith extending peripherally of said opening, and the visible surface of said peripheral wall having a plurality of closely spaced peripherally extending parallel grooves to reduce the intensity of light reflected by the visible surface of said wall.

2. A metal frame for windows and doors according to claim 1 in which the lower surfaces of said grooves are painted.

3. A metal frame for windows and doors according to claim 1 in which the glass-receiving channel is positioned adjacent one of said front and rear surfaces, and further comprising a second sash having a light opening, coupled to the first-mentioned sash with the light openings in register and disposed against the one of said front and rear surfaces of the first-mentioned sash remote from the glass-receiving channel.

4. A metal frame for windows and doors according to claim 3 in which the lower surfaces of said grooves are painted.

ERIC SIGFRID PERSSON.

References Cited in the file of this patent
UNITED STATES PATENTS

Number	Name	Date
2,282,531	Schunk	May 12, 1942
2,301,694	Geyser	Nov. 10, 1942

OTHER REFERENCES

- The Michigan Copper and Brass Company catalogue. Received in U. S. P. O. Feb. 1930.
Article "Modern Wall Finishes" pages 52 and 53, "American Builder" of August 1938.