

(12) UK Patent Application (19) GB (11) 2 317 106 (13) A

(43) Date of A Publication 18.03.1998

(21) Application No 9619050.9

(22) Date of Filing 12.09.1996

(71) Applicant(s)  
Michael Alexander  
The White House, Long Lane, Hermitage, NEWBURY,  
Berkshire, RG16 9LY, United Kingdom

(72) Inventor(s)  
Michael Alexander

(74) Agent and/or Address for Service  
Rock & Co  
Trelawn, Cassington, OXFORD, OX8 1DN,  
United Kingdom

(51) INT CL<sup>6</sup>  
A61G 7/015 7/005

(52) UK CL (Edition P)  
A4L LATD LBRF LC23 LC52 LC53 LC56 L101 L104 L111  
U1S S1207 S1208

(56) Documents Cited  
GB 0836628 A EP 0178951 A2 US 5072463 A  
US 4862529 A US 4613997 A

(58) Field of Search  
UK CL (Edition O) A4L LATD LBRF LCC  
INT CL<sup>6</sup> A61G 7/00 7/005 7/015

(54) Support unit for invalids

(57) A support unit movable between horizontal (Figs 1,2) and substantially upright positions comprises a chassis 12, a human body carrier 14 with trunk, thigh and leg sections 15,16,17, and a frame 22 slidably supporting the trunk section. Sections 15,16 and 16,17 are pivoted at A and B respectively. The frame has a greater plan area than the chassis and is pivotally supported at C by a ram 21 providing height adjustment. A second ram 24 attached to an extension (21B, Fig 1) of ram 21 tilts the frame between horizontal and upright positions. Pivoting of sections 16,17 relative to section 15 is limited by a link 40 connecting the end of the frame with the pivot B, and by a curved restraint D. A third ram (25, Fig 3B) slides section 15 relative to the frame, thus pivoting sections 16,17 as shown or bringing them into horizontal alignment with section 15. The rams may be under programmed control. A retractable extension 33 on the chassis may provide additional support in the horizontal position.

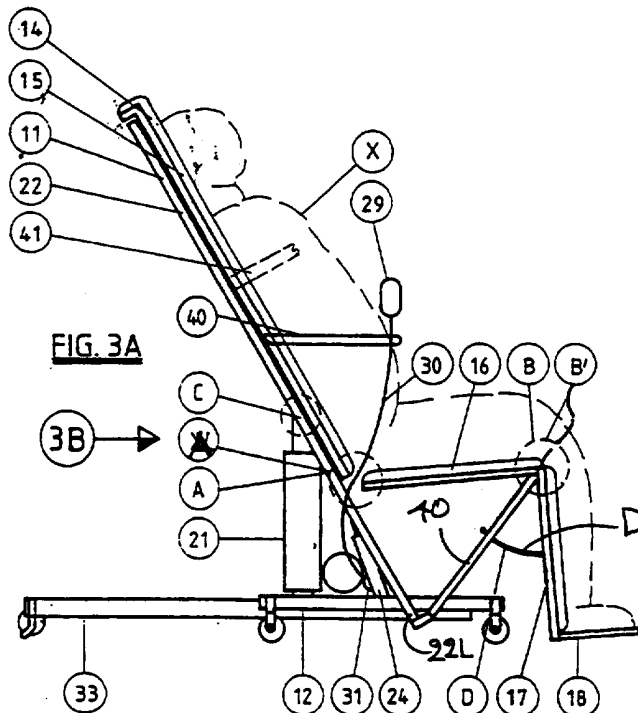

GB 2 317 106 A

At least one drawing originally filed was informal and the print reproduced here is taken from a later filed formal copy. The claims were filed later than the filing date within the period prescribed by Rule 25(1) of the Patents Rules 1995. This print takes account of replacement documents submitted after the date of filing to enable the application to comply with the formal requirements of the Patents Rules 1995.

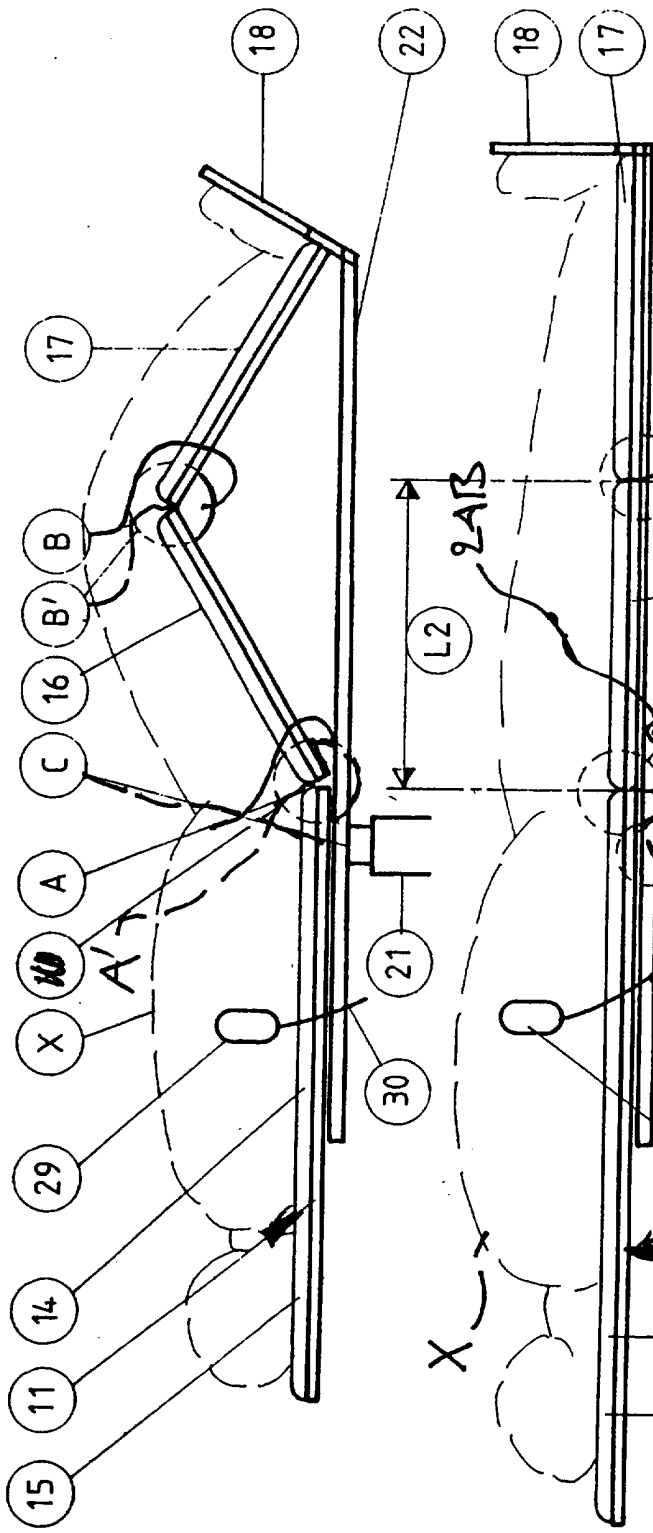

FIG. 1



FIG. 2

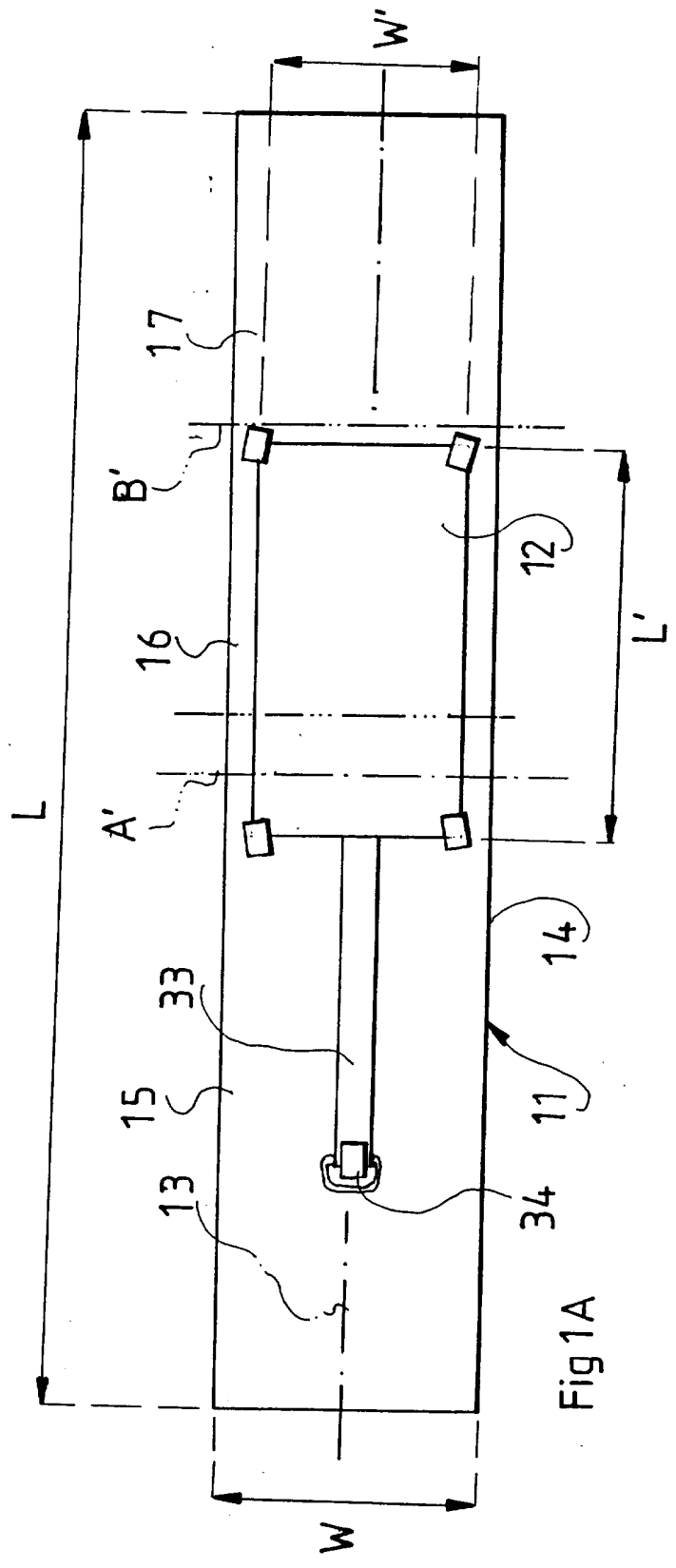
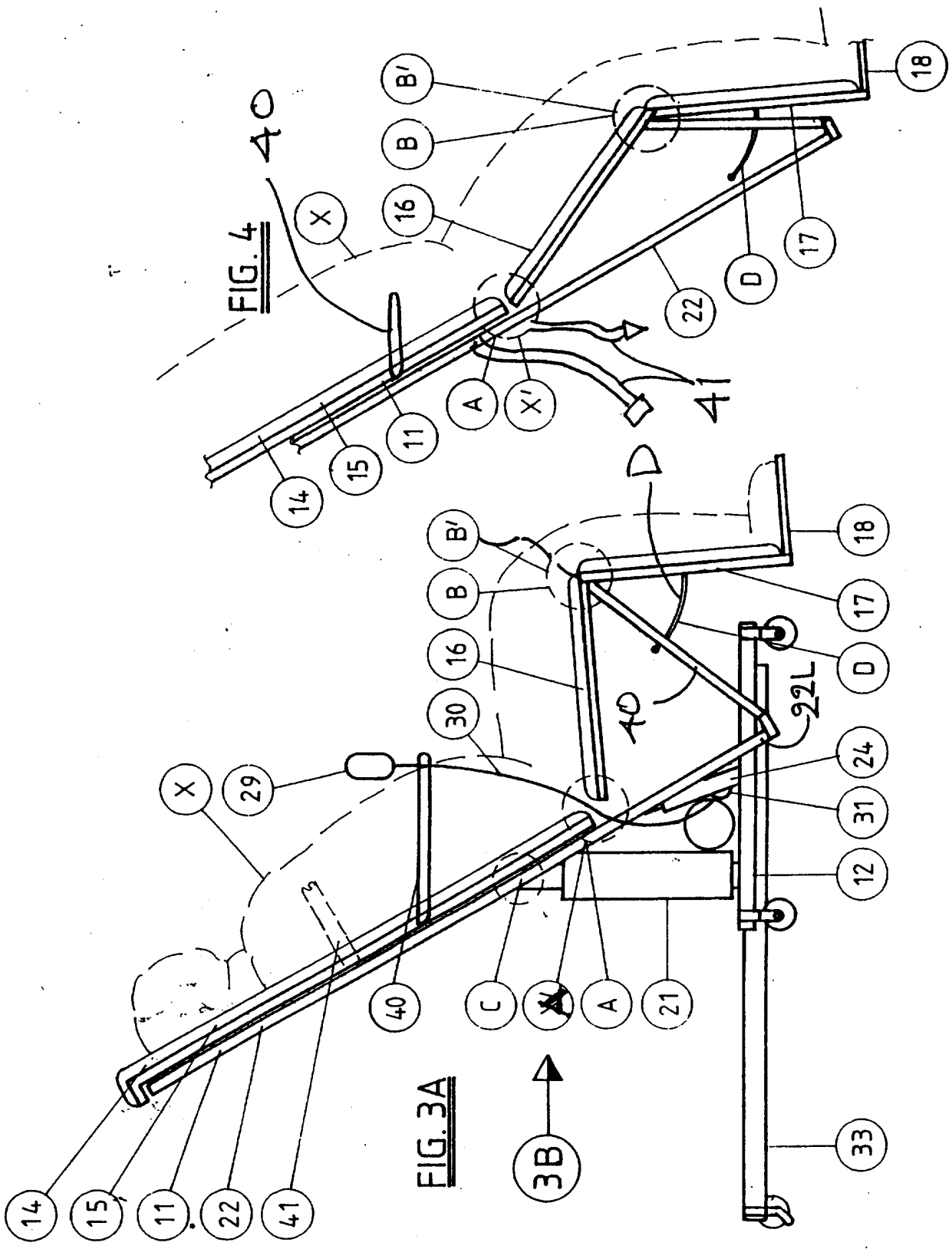

Fig 1A



**FIG. 3A**

**FIG. 4**

FIG. 3B

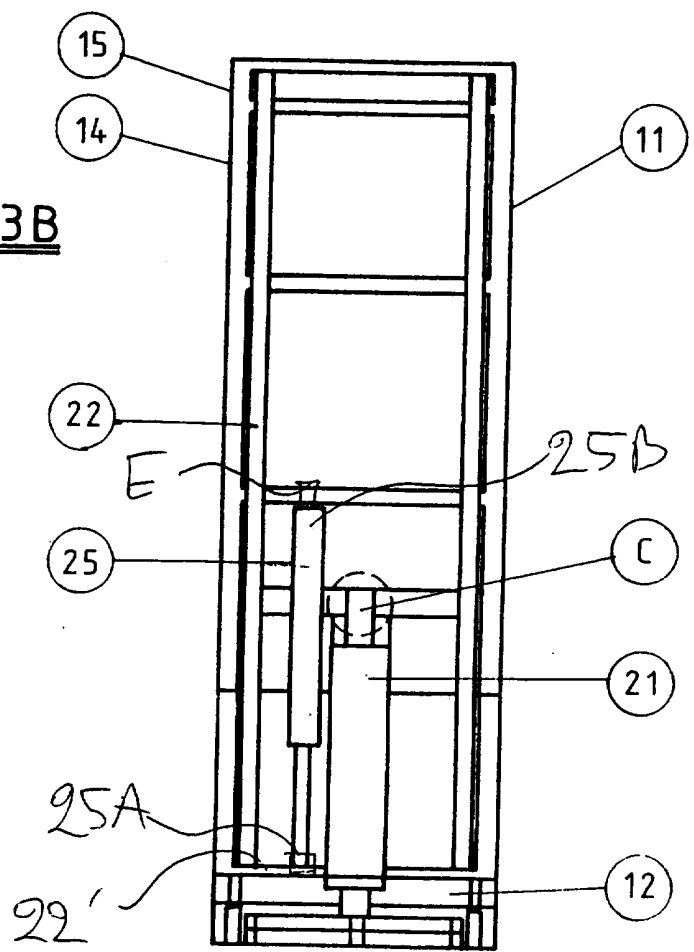

## SUPPORT UNIT

This invention relates to a support unit. It is in particular concerned with a support unit for an individual suffering from spinal or other incapacitating injuries to enable them to be supported in various attitudes. For such a person there frequently arises a need to provide for the body to be capable of relative changes in position and for changes to occur at frequent intervals. Thus for comfort and for physio-therapeutic benefits there can be advantages in providing for relative difference in alignment between the three main body sections the head and trunk, the thighs and the legs. In addition alignment changes of the head relative to the trunk and of the feet relative to the legs provide advantages. In a completely reclined posture it is necessary to maintain the three main body sections in line on what amounts to a flat surface (though this need not necessarily be horizontal). As recovery occurs or for nursing requirements there can arise a need to raise, while maintaining full support for, the trunk so as to align it at an angle relative to the thighs and legs. A further need can arise for a patient to sit up so that the trunk and legs are near vertical and the thighs near horizontal. Finally there are benefits to be had from supporting the patient in a vertical or near vertical position.

European Patent Publication 0 178 951 (Grantham) shows a convertible hospital bed in which an upper bed frame, bearing a mattress, which is movable over a lower bed frame towards the foot of the bed while elevating the trunk of the occupant. In this way the occupant arrives at the foot of the bed in an upright seated position. In this case the bed serves as a stable framework on which the occupant can readily be moved. Grantham acknowledges that the invention is for beds of the 'hospital' type 'being particularly designed for use in hospitals and nursing homes or for residential use with patients who are possibly ambulatory but too weak or incapacitated to get into and out of bed without assistance'.

US Patent 4 613 997 (Langdale) discloses a convalescent bed with a base frame and support frame for a mattress pivotally mounted for movement between horizontal and vertical positions. The support frame provides a support portion for the trunk and legs and a hinged portion for the head. The bed is provided with power mechanism to move the support frame as a unit between horizontal and vertical

positions. No seating position is provided. As with EPO 0178951 Langdale relies on the structural support provided by a full size bed frame during movement of the support frame. The bed disclosed by Langdale also requires operation by skilled staff.

According to the present invention there is provided a support unit comprising:

- (1) a chassis,
- (2) a working carrier for a human body comprising-
  - a first section for the trunk,
  - a second section for the thighs, and
  - a third section for the legs;
 a waist coupling between the first section and the second section enabling the first and second section to rotate relative to one another about a waist axis;
  - a knee coupling between the second section and the third section enabling the second section to rotate relative to one another about a knee axis;
  - the waist axis being parallel to the knees axis and separated substantially by the length by the second section;
  - the working carrier, at least with the first, second and third sections lying in a substantially common horizontal plane, having in plan overall dimensions substantially greater than the overall dimensions in plan of the chassis;
- (3) a frame member slidably retaining the first section and to support the working carrier at least when the working carrier is at or near the horizontal;
- (4) a column of variable length extending between the chassis and the frame member to support the frame member and to provide for height adjustment of the frame member;
- (5) a link having a first end pivotably attached to the frame member and the other end to the first end pivotably attached to the second section or an extension thereof in the region of the knee axis; the link serving to limit rotation of the second section towards the first at least when the first section is tilted from the horizontal;
- (6) a first longitudinal actuator having a first end pivotably attached to the column or an extension thereof and the other end to the first end pivotably attached to the frame member; the first actuator being of variable length between the first end and the other end to the first end to enable the frame

member, and so the working carrier, to be rotated relative to the chassis about a horizontal main axis;

- (7) a second longitudinal actuator having a first end pivotably attached to the frame member or an extension thereof and the other end to the first end pivotably attached to the first section; the second actuator being of variable length between its first end and its other end to the first to enable the first section to be displaced linearly relative to the working carrier;
- (8) control means regulating operation of the column and the alignment means; and
- (9) means for energising the column and alignment means;

According to a first preferred version of the present invention the third section is provided with a foot rest.

According to a second preferred version of the present invention or the first preferred version thereof there are provided arm or shoulder supports or rests mounted on the first section.

According to a third preferred version of the present invention or any preceding preferred version thereof including retaining means such as a belt for retaining an occupant relative to the working carrier.

According to a fourth preferred version of the present invention or any preceding preferred version thereof the means for energising is a mains electrical supply, storage battery or a source of compressed fluid.

According to a fifth preferred version of the present invention or any preceding preferred version thereof the chassis is provided with ground engaging means such as wheels or tracks providing for mobility of the unit.

According to a sixth preferred version of the present invention or any preceding preferred version thereof there is provided a stabilising member which can be extended from the chassis or an extension thereof into ground engagement to increase stability of the unit; the stabilising member being retractable into the chassis



or the extension thereof to enable the chassis alone to support the remainder of the unit. typically the chassis is provided wherein the stabilising member comprises a longitudinally extendible beam and an associated ground engaging means such as a wheel so that, at least with the three sections substantially horizontally, the extendible beam is automatically or otherwise deployed so that the associated ground engaging means contacts the ground at some distance from the remainder of the chassis to increase stability of the unit.

According to a seventh preferred version of the present invention a support unit according to the fifth preferred version includes at least one motor adapted for powering by the means for energising some or all of the ground engaging means to provide for propulsion of the support unit.

According to an eighth preferred version of the present invention or any preceding preferred version thereof there is provided an anchoring means, such as a jack, which is automatically or otherwise deployed with the unit in a given configuration to resist displacement of the unit relative to the ground.

According to a ninth preferred version of the present invention or any preceding preferred version thereof the control means includes a control unit providing for the input of signals for controlled operation of the unit whether by manual manipulation, breath control, muscle or nerve sensing or in some other way compatible with the ability of an occupant of the support unit.

According to a tenth preferred version of the present invention a support unit according to the ninth preferred versions includes a further control unit providing for the input of signals for controlled operation of the unit which signals are adapted to override or otherwise suppress those of the control unit.

According to an eleventh preferred version of the present invention a support unit according to the ninth or tenth preferred versions has a control means including programmed information governing the type of operation (or the rate, or a function thereof, at which it can occur) that can be undertaken on the input of signals by way of the control unit and/or the further control unit.

The support unit of the present invention by facilitating movement of a patient will benefit carers and nurses who with currently available methods of patient handling, especially lifting, suffer back and muscular problems lead to an inability to undertake lifting if not absence from work for an extended period.

Mobile version of the present invention provides for stable and ready movement of the unit with an occupant. Such a version can include one or more motor driven wheels or tracks which can be used to propel the unit with its occupant when an occupant can safely do so the control system can be operated by the occupant. The ability provided by the unit to enable an occupant to regulate his immediate physical support and experience a degree of mobility can provide a major psychological benefit. This can be especially significant when the incapacity of the occupant has arisen suddenly following a major accident prior to which the occupant was physically extremely active.

An exemplary embodiment of the invention will now be described with reference to the accompanying drawings of a spinal support unit of which:

Figure 1 is a side view of the unit with the component parts in a first relative position with a user lying horizontally;

Figure 1A is a plan view from underneath in direction of arrow 1A shown in Figure 1.

Figure 2 is a side view of the unit with the component parts in a second relative position with a user lying in a knees raised position;

Figure 3A is a side view of the unit with the component parts in a third relative position with a seated user;

Figure 3B is a rear end view of the unit in the direction of arrow 3B shown in Figure 3A; and

Figure 4 is a side view of a major part of the unit with the component parts in a fourth relative position with a user in a supported and near standing position.

The drawings variously show a spinal support unit 11 with a wheeled chassis 12 having a longitudinal axis 13 on which is mounted a working carrier 14. The working carrier 14 serves to support an occupant X shown in broken outline. The

carrier 14 is in three distinct sections 15, 16, 17 capable of relative rotational movement. The first segment 15 serves to support the trunk of the occupant X; the second segment 16 to support the thighs; and the third segment 17 the legs (and is in addition equipped with a foot rest 18 to prevent longitudinal movement of occupant X relative to the carrier 14).

The first section 15 of support is pivotably attached by coupling A to the second section 16 to enable the first section 15 to be rotated relative to the second section 16 about waist axis A'.

The second section 16 is pivotably attached by coupling B to the third section 17 to enable the second section 16 to be rotated relative to the third section 17 about knee axis B' which is parallel to waist axis A' and off set from it by an amount corresponding to length L2 of the second section 16.

An electro-mechanical ram 21 with piston 21A serves to support frame 22 which in turn slidably supports first section 15. The ram 21 serves to vertically raise or lower frame 22 and so carrier 14. The ram 21 is coupled by pivot C to the support frame 22 to enable the frame 22 to be pivoted about main axis C' by means of a first actuator 24 which is pivotably attached: at end 24A to extension 21B of the ram 21 and at end 24B to frame 22. By varying the length of the first actuator 24 the support frame 22 can be rotated about axis main C' from the horizontal as shown in Figure 1 to the near vertical as shown in Figure 4.

A second actuator 25 (shown only in Figure 3B) is pivotably attached: at end 25A to cross member 22' and at end 25B to extension E on the underside of first section 15 of the carrier 14. By varying the length of the second actuator the first section 15 can be displaced relative to the carrier frame 22 by means of longitudinal tongues on the sides of section 15 slidably engaging complementary slots in the frame 22.

The remaining second section 16 and third section 17 while not engaging directly with support frame 22 do seat upon the support frame when it is horizontal and they are lying in the same plane as the first section 15. They are constrained in other ways to respond to displacement of first section 15 under linear displacement by second

actuator 25 so as to adopt configurations other than the horizontal shown in Figure 1.

Figure 1A shows the unit in the configuration of Figure 1 seen from underneath working carrier 14 in its fully extended horizontal position with outside dimensions length L and width W. The chassis 12 with outside dimensions length L' and width W' is shown off-set to one side of the main axis C'. It will be seen that the outside dimensions L', W' of the chassis are substantially less than the outside dimensions L, W of the working carrier 14. To provide for enhanced stability for the unit 11 in this configuration an extendible extension leg 33 is provided with a ground engaging wheel brace and wheel arrangement 34 mounted for rearward extension from the chassis 12 to the position shown. When the working carrier 14 is realigned to take up the configuration shown in Figures 3 and 4 the extension leg 33 is retracted so that the unit 11 is carried on the chassis 12 alone.

The unit 11 is powered in this case by way of a mains supply cable 28. For a fully mobile arrangement one or more batteries can be located well down on the chassis 12 so providing for enhanced stability for the unit as a whole by lowering the centre of gravity of the unit 11 from that arising when no batteries are used.

Operation of the ram 21, first actuator 24 and second actuator 25 is regulated by way of a hand control 29 coupled by cable 30 to processor 31 which incorporates a programmed memory incorporating safety factors which ensure that the user cannot cause, whether inadvertently or not, a dangerous or inconvenient sequence of events to occur. The hand control 29 can be operated by an occupant of the bed or by a carer for the occupant. If necessary if the hand control 29 is to be operated by the user means can be provided limiting what can be achieved by way of the hand control. An override control is fitted for the purpose of safety for manual use by the carer.

Figure 2 shows the unit 11 with the second section 16 and third section 17 raised to provide an angled leg position for the occupant whose trunk remains substantially level on section 15.

The transition from the configuration shown in Figure 1 to that in Figure 2 is achieved by operating the second actuator 25 to cause the first section 15 to be drawn to the right from the extended position shown in Figure 1 where sections 16, 17 rest on the working carrier 14. By displacing first section 15 to the right second section 16 is caused to pivot in an anti-clockwise direction about axis A' and third section 17 is caused to pivot in a clock-wise direction about axis B'. The speed of this transition is governed to ensure that the occupant X is not subject to any significant strains and ensures that the underside of virtually all parts of the body are supported.

Figures 1 to 2 show relative locations in which the working carrier 14 is maintained horizontal relative to main axis C by way of first actuator 24.

Figures 3A and 3B variously show the unit 11 configured as a seat where the first segment 15 and the third section 17 is positioned at a position approaching the vertical as is convenient. To support the occupant X when the working carrier is moved from the horizontal arm rests 41 are pivoted to project upwardly from the first section 15 to which they are pivotably attached.

Progression to the sitting and thereafter standing configuration from that shown in Figure 2 is achieved from the configuration of Figure 2 by:

operating first actuator 24 to tilt the carrier frame 22 about main axis C in a clockwise direction; and

operating the second actuator 25 to draw the first section 15 further to the right so causing the second section 16 to pivot in an anticlockwise direction so reducing the angle H between the first and second sections in Figure 2 to the angle S in Figure 3.

A link 40 (Figure 3A) is provided pivotably linking lower end 22L of frame 22 and forward end of second section 16 in the vicinity of axis B'. link 50 serves to constrain movement of the second section 16 and third section 17 when the carrier frame 22 tilts towards the vertical. Motion of the third section 17 is further constrained by a curved restraint D so that the third section 17 cannot pivot further in a anti-clockwise direction relative to the second section 16 as the first section rises towards the vertical. This serves to prevent any undue strain being placed on the knees and legs of the occupant X.

Figure 4 shows the upper parts of the unit 11 where the occupant X has been raised to a near standing position while provided with support by way of arm rests 40. If necessary the effect of the arm rests 40 can be in addition to a retaining strap 41 across the chest of the occupant X.

The transitions between the various configurations shown in the figures are programmed to occur at a reasonable rate and without the relative positions of the sections ever ceasing to provide a degree of support or at least of alignment for all parts of the body of the occupant. The control unit 31 is programmed to ensure that the rates and rates of change of relative movement between the various sections of the support do not adversely affect the occupant.

The ram 21 provides for the vertical height of the sections when bearing the occupant to be readily controlled. This is particularly beneficial for transferring the occupant between the unit 11 and, say, a bed. The sections 15-17 of the unit are readily raised or lowered relative to the horizontal to lie in common plane with the bed top so enabling a carer to move the occupant from one to the other.

A major benefit of the unit according to the present invention is the ability it provides for an occupant to be able to configure the unit, and so their own bodies, in a configuration suitable for a subsequent action in their own time without the need for a carer to be present. For the permanently disabled this can serve to generate a degree of independence having psychological and other advantages. In the event the occupant has not got, or cannot make use, of a hand then the hand control 29 can be replaced by a control which is located for ready operation by the occupant adapted for operation by whatever action can be provided by the occupant such as finger movement, blowing or sensing means able to detect two levels of state of muscle, nerve or other function which levels can be decoded or otherwise detected and used to govern unit functions.

In an alternative embodiment a unit corresponding in other respects to unit 11 can be provided with propulsion means to enable the combination of occupant and unit to drive or be driven. Again the control unit can be used to provide interlocks or other regulation so that the unit can only be moved when the sections supporting the

occupant are in a suitable configuration.

It will be apparent that the invention provides a compact means for providing safe overall support to an occupant while providing for controlled movement of parts of the occupants body between various configurations. The unit of the present invention is relatively compact and readily moved around in limited space such as can arise in a domestic or residential environment.

The unit provides support over a range from fully extended occupant lying flat to a raised knee position with thigh and legs at an angle to each other and to the body to a seated position to a fully upright or near upright stance. All movement are governed by actuators and a ram whose operation is readily controlled by a micro-processor.

Brakes, jacks or wheel lifts can be provided to ensure that, for example, when the unit is aligned with, say, a bed to ensure that there will be no movement of the unit relative to the bed while transfer of an occupant is made from the unit to the bed or vice versa. Means can also be provided to ensure that the footplate 18 can be anchored to the floor when the sections approach the upright position shown in Figure 4. In passing from the configuration shown in Figures 1 or 2 to the seated position shown in Figure 3 and on to the near standing one in Figure 4 the micro processor provides for the extension leg 33 to retract into the chassis 12 so causing less obstruction at the rear of the unit.

The arm supports 40 can likewise be extended or retracted automatically as the unit moves towards or away from the vertical as shown in Figure 4 to ensure that the upper part of the body of an occupant is supported.

A unit based on the present invention is capable of being equipped with items from a wide range of adjuncts and accessories depending on the particular applications required. A unit according to the present invention can be equipped with equipment such as a wireless whereby an occupant can readily signal for assistance in the event a problem arises.

## CLAIMS

- 1 A support unit comprising:
- (1) a chassis,
  - (2) a working carrier for a human body comprising-
    - a first section for the trunk,
    - a second section for the thighs, and
    - a third section for the legs;
 a waist coupling between the first section and the second section enabling the first and second section to rotate relative to one another about a waist axis;  
 a knee coupling between the second section and the third section enabling the second section to rotate relative to one another about a knee axis;  
 the waist axis being parallel to the knees axis and separated substantially by the length by the second section;  
 the working carrier, at least with the first, second and third sections lying in a substantially common horizontal plane, having in plan overall dimensions substantially greater than the overall dimensions in plan of the chassis;
  - (3) a frame member slidably retaining the first section and to support the working carrier at least when the working carrier is at or near the horizontal;
  - (4) a column of variable length extending between the chassis and the frame member to support the frame member and to provide for height adjustment of the frame member;
  - (5) a link having a first end pivotably attached to the frame member and the other end to the first end pivotably attached to the second section or an extension thereof in the region of the knee axis; the link serving to limit rotation of the second section towards the first at least when the first section is tilted from the horizontal;
  - (6) a first longitudinal actuator having a first end pivotably attached to the column or an extension thereof and the other end to the first end pivotably attached to the frame member; the first actuator being of



variable length between the first end and the other end to the first end to enable the frame member, and so the working carrier, to be rotated relative to the chassis about a horizontal main axis;

- (7) a second longitudinal actuator having a first end pivotably attached to the frame member or an extension thereof and the other end to the first end pivotably attached to the first section; the second actuator being of variable length between its first end and its other end to the first to enable the first section to be displaced linearly relative to the working carrier;
- (8) control means regulating operation of the column and the alignment means; and
- (9) means for energising the column and alignment means.

- 2 A support unit as claimed in Claim 1 wherein the third section is provided with a foot rest.
- 3 A support unit as claimed in any preceding claim provide with arm or shoulder supports or rests mounted on the first section.
- 4 A support unit as claimed in any preceding claim including means such as a belt for retaining an occupant relative to the working carrier.
- 5 A support unit as claimed in any preceding claim wherein the means for energising is a mains electrical supply, storage battery or a source of compressed fluid.
- 6 A support unit as claimed in any preceding claim wherein the chassis is provided with ground engaging means such as wheels or tracks providing for mobility of the unit.
- 7 A support unit as claimed in any preceding claim including a stabilising member which can be extended from the chassis or an extension thereof into ground engagement to increase stability of the unit; the stabilising member being retractable into the chassis or the extension thereof to enable the chassis

alone to support the remainder of the unit.

- 8 A support unit as claimed in Claim 7 wherein the chassis is provided wherein the stabilising member comprises a longitudinally extendible beam and an associated ground engaging means such as a wheel so that, at least with the three sections substantially horizontally, the extendible beam is automatically or otherwise deployed so that the associated ground engaging means contacts the ground at some distance from the remainder of the chassis to increase stability of the unit.
- 9 A support unit as claimed in Claim 6 including a motor adapted for powering by the means for energising some or all of the ground engaging means to provide for propulsion of the support unit.
- 10 A support unit as claimed in any preceding claim including an anchoring means, such as a jack, which is automatically or otherwise deployed with the unit in a given configuration to resist displacement of the unit relative to the ground.
- 11 A support unit as claimed in any preceding claim wherein the control means includes a control unit providing for the input of signals for controlled operation of the unit whether by manual manipulation, breath control, muscle or nerve sensing.
- 12 A support unit as claimed in Claim 10 or Claim 11 wherein a further control unit is provided providing for the input of signals for controlled operation of the unit which signals are adapted to override or otherwise suppress those of the control unit.
- 13 A support unit as claimed in Claim 11 or Claim 12 wherein the control means includes programmed information governing the type of operation (or the rate, or a function thereof, at which it can occur) that can be undertaken on the input of signals by way of the control unit and/or the further control unit.

- 14 A support unit as hereinbefore described with reference to and as illustrated in the accompanying drawings.



Application No: GB 9619050.9  
Claims searched: ALL

Examiner: R E Hardy  
Date of search: 17 January 1997

**Patents Act 1977**  
**Search Report under Section 17**

**Databases searched:**

UK Patent Office collections, including GB, EP, WO & US patent specifications, in:

UK Cl (Ed.O): A4L (LATD, LBRF, LCC)

Int Cl (Ed.6): A61G (7/00, 7/005, 7/015)

Other:

**Documents considered to be relevant:**

Category	Identity of document and relevant passage	Relevant to claims
A	GB0836628 A BREACH : Whole document	1
A	EP0178951 A2 GRANTHAM : Whole document	1
A	US5072463 A WILLIS : Whole document	1
A	US4862529 A PECK : Whole document	1
A	US4613997 A LANGDALE : Whole document	1

X	Document indicating lack of novelty or inventive step	A	Document indicating technological background and/or state of the art.
Y	Document indicating lack of inventive step if combined with one or more other documents of same category.	P	Document published on or after the declared priority date but before the filing date of this invention.
&	Member of the same patent family	E	Patent document published on or after, but with priority date earlier than, the filing date of this application.