

19



Europäisches Patentamt  
European Patent Office  
Office européen des brevets



11 Publication number:

**0 469 453 A1**

12

### EUROPEAN PATENT APPLICATION

21 Application number: **91112409.7**

51 Int. Cl.<sup>5</sup>: **A63C 9/08**

22 Date of filing: **24.07.91**

30 Priority: **30.07.90 IT 8260890**

43 Date of publication of application:  
**05.02.92 Bulletin 92/06**

84 Designated Contracting States:  
**AT CH DE FR IT LI**

71 Applicant: **NORDICA S.p.A**  
**Via Piave, 33**  
**I-31044 Montebelluna (Treviso)(IT)**

72 Inventor: **Baggio, Giorgio**  
**Via Lamarmora, 30**  
**I-35018 San Martino di Lupari, Padova(IT)**  
Inventor: **Pincin, Antonio**  
**Via Bassanese, 28**  
**I-31044 Montebelluna, Treviso(IT)**

74 Representative: **Modiano, Guido et al**  
**MODIANO, JOSIF, PISANTY & STAUB**  
**Modiano & Associati Via Meravigli, 16**  
**I-20123 Milano(IT)**

54 **Ski binding with a device for displaying the safety load for the release of a ski boot.**

57 A ski binding, which has a device for displaying the safety load for the release of a ski boot, including: a position sensor (2), which sends a signal to an electronic circuit for detecting, converting and processing the signal; a display device, a switch and a power source. The peculiarity of the device consists

of the fact that the position sensor is constituted by a capacitive sensor (8,9) or by a plurality of micro-switches which send the signal according to the variation in the position of a screw (11) for the adjustment of the securing of the binding (1).

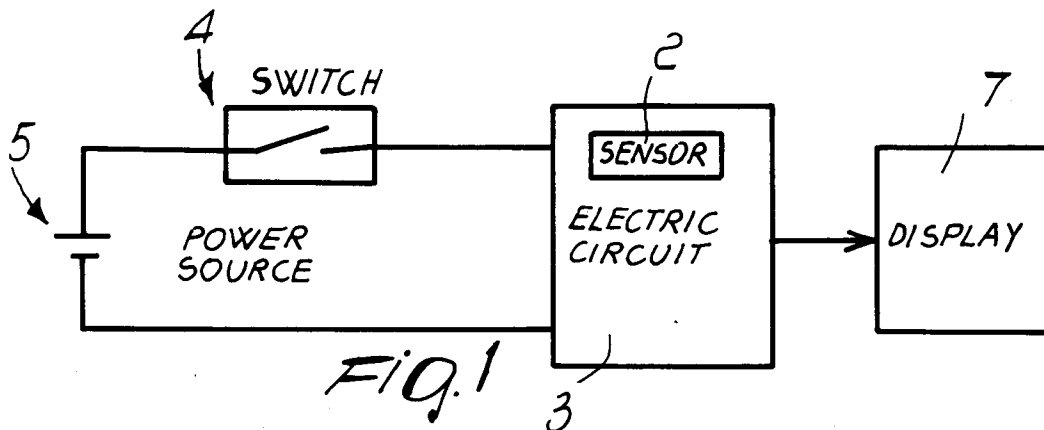

EP 0 469 453 A1

The present invention relates to a ski binding with a device for displaying the safety load for the release of a ski boot.

Ski bindings are known which have an electronic device displaying data, usually numbers, which indicate to the skier the degree of securing which can be achieved for the ski boot.

Some of these bindings have a transducer which is suitable for detecting the force imparted to a spring during the adjustment of the binding, said transducer emitting a signal which, after being appropriately treated, drives an electronic display.

This solution is per se not optimum, since the force detection apparatus is expensive and extremely delicate, considering the conditions (vibrations, impacts, low temperatures) to which the ski binding is subjected.

Ski bindings are also known in which a potentiometer is used as a position sensor; said potentiometer is constituted by a slider which can slide in an adapted guide and the movement whereof is interpreted by an appropriate electric circuit, measuring a variation in resistance.

The disadvantage which can be observed in this known type of binding resides in the fact that the possible presence of material at the slider seat may lead to an alteration of the value of the resistance read by the circuit, thus generating incorrect data at the display.

The aim of the present invention is therefore to eliminate the disadvantages described above in known types by providing a ski binding wherein it is possible to display, in a precise and therefore as error-free as possible manner, the safety load for the release of a ski boot.

Within the above aim, an important object is to provide a reliable device and safe in use which provides correct indications as to the safety load set on the binding for the release of the boot.

Another important object is to provide a structurally simple binding and easy to industrialize.

Not least object is to provide a binding which associates with the preceding characteristics that of having modest costs.

This aim, these objects and others which will become apparent hereinafter are achieved by a ski binding with a device for displaying the safety load for the release of a ski boot, characterized in that it comprises a position sensor which sends a signal to an electronic circuit for detecting, converting and processing said signal, a display device, a switch and a power source, said position sensor sending said signal according to the variation in the position of a screw for the adjustment of the safety load of said binding.

Further characteristics and advantages of the invention will become apparent from the detailed description of some particular but not exclusive

embodiments, illustrated only by way of non-limitative example in the accompanying drawings, wherein:

figure 1 is a schematic view of the components of the invention;

figure 2 is a partially sectional view of the arrangement of the capacitive sensor;

figures 3 and 4 are two diagrams of the electric circuit;

figure 5 is a further block diagram of the components of the invention;

figure 6 is a view, similar to that of figure 2, of the arrangement of the microswitches;

figure 7 is a view of an embodiment to be combined with the preceding one, which gives a better degree of precision to the embodiment of figure 6;

figure 8 is a front view of the threaded bush on which the fixed contacts are applied.

With reference to the above figures, the ski binding, which is constituted by at least one coupling element 1 for a ski boot, such as a heel or tip element, has a position sensor 2 which sends a signal to an electric circuit 3, which can be activated by means of an adapted switch 4 accessible to the skier and is powered by means of an adapted power source 5.

The electric circuit 3 may comprise control logic unit 6 for detecting, converting and processing the signal arriving from the sensor 2 to send it to a display 7 which can be associated with the ski binding.

In the particular embodiment illustrated in figure 2, the position sensor is constituted by a capacitive sensor and therefore by a variable capacitor which has a first plate 8 and a second plate 9 which face one another and are electrically insulated by means of insulating material 10.

The first plate 8 is movable and is advantageously constituted by the cylindrical surface of the stem of the screw 11 for adjusting the safety load which can be achieved for the release of a ski boot.

Said screw 11 is advantageously rotatably associated at the frame 12 of the coupling element 1, and at least one spring 13 is provided inside said screw; said spring is suitable for presetting, by means of known devices, the degree of securing for the boot.

The insulating material 10 is arranged coaxially to the first plate 8, and a second plate 9 is arranged coaxially to said insulating material; said second plate 9 is also cylindrical and is fixed at the frame 12.

In a different embodiment, the first and second plates can be constituted by two facing planar surfaces instead of by coaxial cylindrical surfaces.

In the embodiment illustrated in figure 2, a rotation of the screw 11 is matched by an axial

movement of the screw stem and therefore by a movement of the first plate 8, achieving a variation in the degree of interference with respect to the second plate 9.

Figures 3 and 4 illustrate an embodiment of the electric circuit 3, which is suitable for measuring the capacitance of the capacitor constituted by the first and second plates; said circuit has advantages in terms of insensitivity to the stability and precision of certain important circuit elements, since it is based on the conversion of a capacitance measurement into a time measurement.

Two measurement steps are thus distinguished which perform, in combination, a double current integration.

As illustrated in figures 3 and 4, a first step occurs in which a reference capacitor  $C_1$  is charged at a constant current  $I$  which is equal to the ratio between the voltage  $V_i$  and a resistor  $R$  across a current integrator 14, the output whereof reaches the final voltage  $V_f$ .

The capacitor with unknown capacitance  $C$  is also raised to the same final voltage, which is given by the formula

$$V_f = V_i - VT/RC_1.$$

The subsequent step entails the discharge of the capacitor being measured, at the end of which the capacitor with unknown capacitance  $C$  is arranged in parallel to the capacitor  $C_1$ , and the voltage  $-V_i$  is applied to the input of the integrator 14 in order to perform the constant-current discharge of the parallel capacitor  $C_1 + C$ .

After a time  $t$ , discharge is complete and is interrupted when the initial voltage  $V_i$  is reached at the output of the integration circuit, schematically indicated by the numeral 15 in figure 5; this condition can be easily detected by means of a known voltage comparator.

The following relations are therefore true:

$$V_i = V_f + Vt/r (C_1 + C)$$

$$t/T = (C_1 + C) / C_1 = 1 + C/C_1.$$

Thus, by measuring the time  $t$  ( $T$  and  $C_1$  being known) it is possible to determine the value of  $C$  and thus detect the adjustment of the binding.

In order to measure  $t$  (and force  $T$ ) there is provided an assembly constituted by an oscillator 16 (time base) and by a counter 17 for the pulses generated by the oscillator.

The display of the number thus obtained is performed according to the type of display 7 used.

Alternatively, it is possible to use an inductive sensor instead of a capacitive one.

Said inductive sensor can be constituted by two mutually coupled coaxial inductors, one being fixed and the other one being movable, with a degree of interfacing which can vary with the position of the safety load adjustment screw, so that the mutual inductance of the overall inductor varies.

An adapted electric circuit finally detects the inductance and/or mutual inductance variation induced by the movement of the load adjustment screw, and activates its appropriate display.

Figure 6 illustrates a further embodiment, wherein the position sensor 102 is constituted by a plurality of microswitches 118, each of which is arranged at one of the intervals into which the overall stroke of the screw 111 is divided.

The identification of said intervals may be performed by means of a combination of fixed contacts 121, which are present at the frame 112 of the coupling element 101, and of movable contacts, such as brushes 119 which are associated at an adapted movable tab 120 which protrudes axially to the screw 111 and interacts with the fixed contacts by sliding.

The tab 120 in fact performs a translatory motion, affecting said fixed contacts, upon a rotation imparted to the screw 111, thus progressively providing the closure between the movable contacts and the fixed contacts.

If the resolution obtainable with the simple division of the axial stroke of the safety load adjustment screw of the ski binding is not sufficient, it can be improved by combining an axial differentiation with an angular differentiation of the rotation of said screw.

Thus, figures 7 and 8 illustrate an embodiment for the angular differentiation of the rotation of the screw, wherein the screw 211 has movable contacts, constituted by brushes 219, which protrude radially therefrom and close on fixed contacts 221 which are provided at a bush 222 which is associated with the frame 212 of the ski binding.

If the screw performs in all a rotation of  $n \times 360^\circ$  and advances by a length  $l_p$  (pitch of the screw) upon a  $360^\circ$  rotation, the overall stroke is  $L = nl_p$ .

It is thus possible to obtain a division of the overall stroke into  $n \times m$  intervals, by dividing the axial stroke into  $n$  sub-intervals associated with as many switches and to further divide each one of said intervals by dividing into  $m$  intervals the rotation of the screw through one turn, again by resorting to fixed and movable contacts.

The numbers of the axial and angular contacts selected by the respective movable contacts are encoded so as to provide an univocal and progressive indication of the position of the adjustment screw.

It has thus been observed that the invention

has achieved the intended aim and objects, a device having been obtained which allows to display to the skier a datum which is proportional to the safety load set for the release of a boot which can be associated with the binding.

The invention is furthermore structurally simple as well as reliable and safe in use.

The activation of the data on the display occurs continuously and automatically once the binding securing adjustment screw alone has been activated.

The device according to the invention is naturally susceptible to numerous modifications and variations, all of which are within the scope of the same inventive concept.

The materials and dimensions which constitute the individual components of the invention may naturally be the most pertinent according to the specific requirements.

Where technical features mentioned in any claim are followed by reference signs, those reference signs have been included for the sole purpose of increasing the intelligibility of the claims and accordingly such reference signs do not have any limiting effect on the scope of each element identified by way of example by such reference signs.

## Claims

1. Ski binding with a device for displaying the safety load for the release of a ski boot, characterized in that it comprises a position sensor (2,102) which sends a signal to an electronic circuit (3) for detecting, converting and processing said signal, a display device (7), a switch (4) and a power source (5), said position sensor sending said signal according to the variation in the position of a screw (11,111,211) for the adjustment of the safety load of said binding. 40
2. Binding according to claim 1, composed of either one of a heel element and a tip element, characterized in that it has a capacitive position sensor which is constituted by a variable capacitor which has a first plate (8) and a second plate (9) which face one another and are electrically insulated by an insulating material (10). 50
3. Binding according to claim 2, characterized in that said first and second plates are arranged on mutually parallel planes. 55
4. Binding according to claim 2, characterized in that said first and second plates are arranged mutually coaxial. 4
5. Binding according to claim 4, characterized in that said first plate is movable and is constituted by the cylindrical surface of the stem of said screw for the adjustment of the safety load of said binding. 5
6. Binding according to claim 5, characterized in that said second plate, which is arranged coaxially to said insulating material and to said first plate, is fixed to the frame (12) of said binding. 10
7. Binding according to one or more of the preceding claims, characterized in that said position sensor is constituted by a plurality of microswitches (118) which are constituted by contacts (121) which are fixed to said frame (112) and by movable contacts (119) which are associated with a tab (120) which is rigidly associated with said screw (111) for the adjustment of the safety load of said binding and protrudes therefrom. 15
8. Binding according to one or more of the preceding claims, characterized in that said position sensor is constituted by a plurality of microswitches which are constituted by fixed contacts (221) at one end of a bush (222) which is associated with said frame (212) and is arranged coaxially to said screw (211) for the adjustment of the safety load of said binding, said screw having movable contacts (219) which face said fixed contacts and protrude radially from said screw. 20
9. Binding according to claim 1, characterized in that said position sensor comprises an inductive sensor. 25

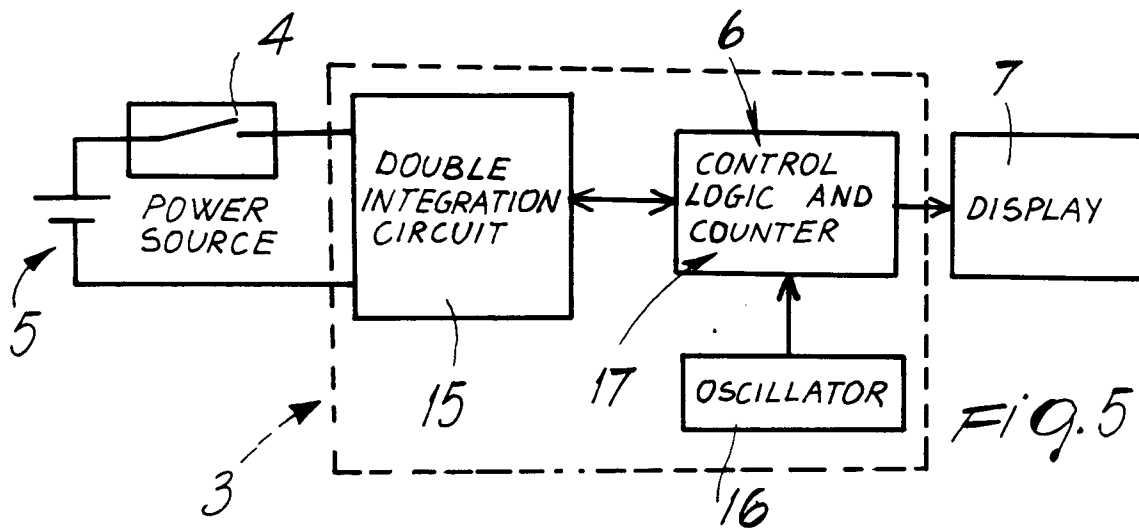
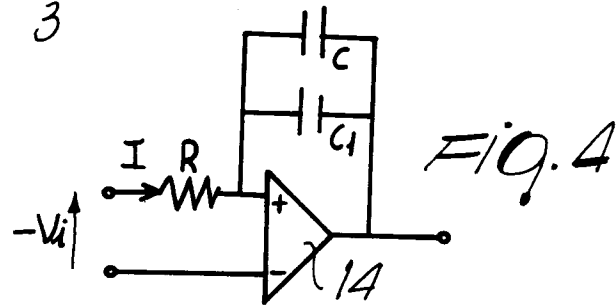
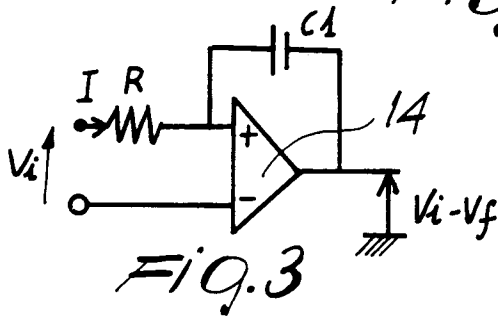
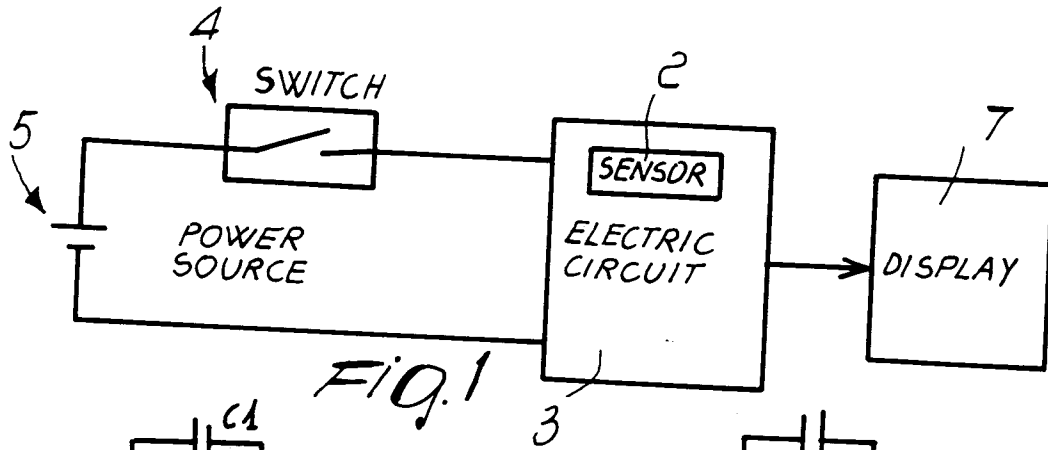
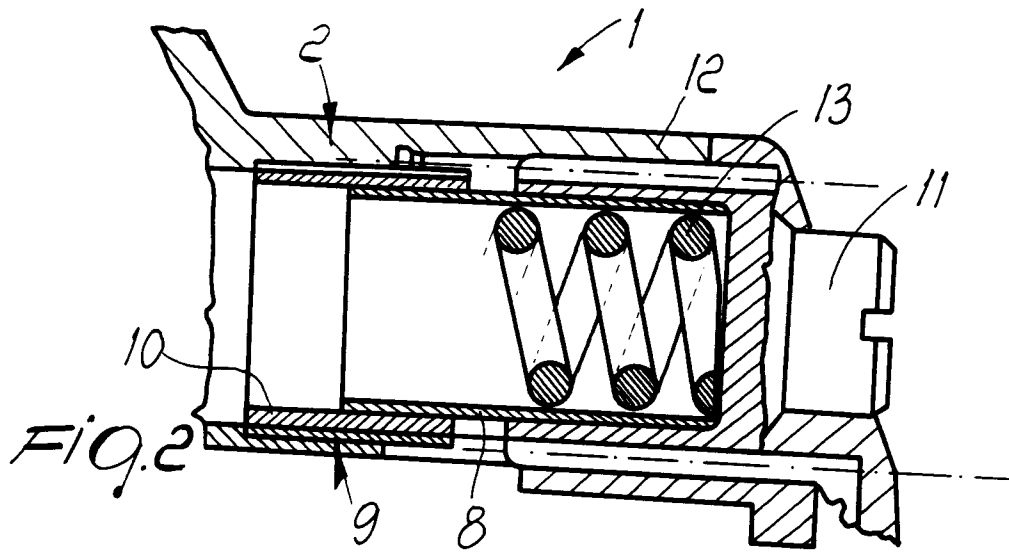

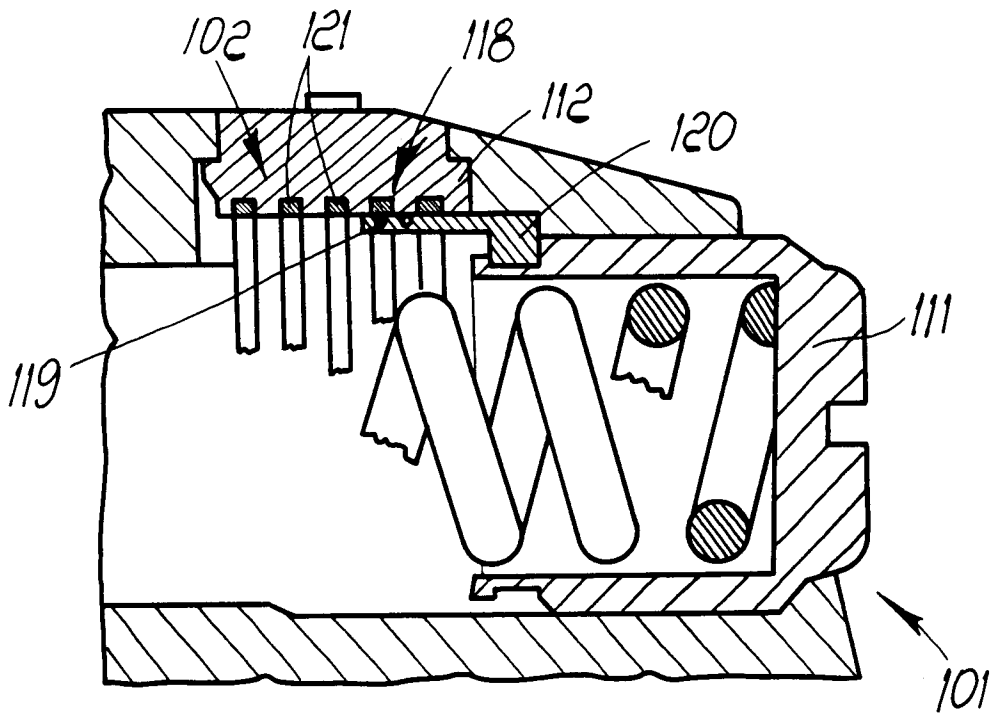

FIG. 6

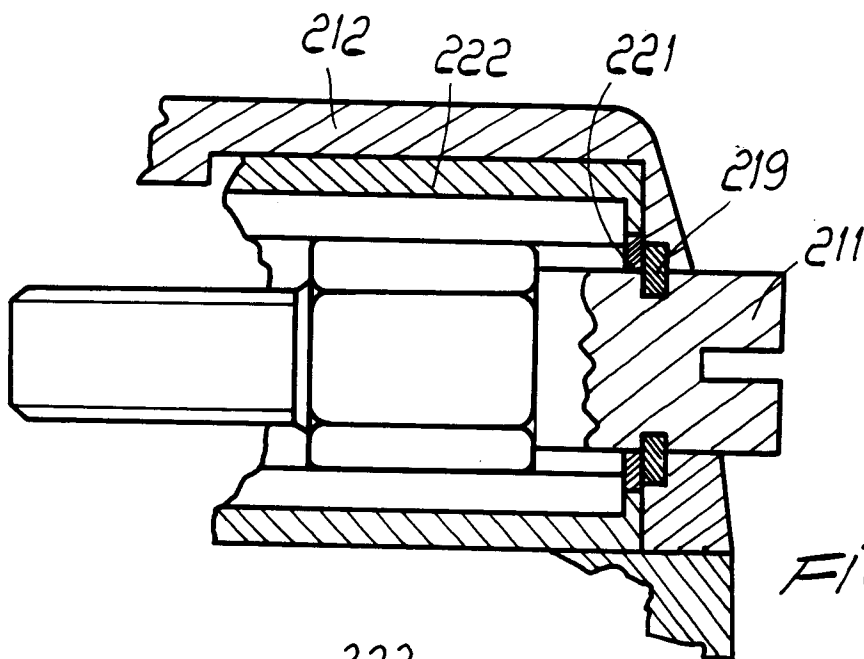

FIG. 7

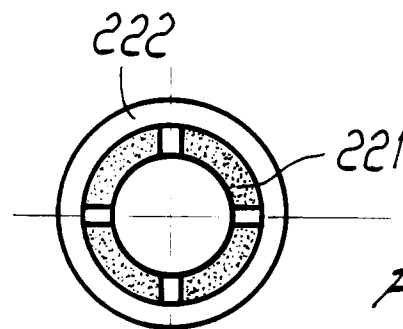

FIG. 8



**EUROPEAN SEARCH  
REPORT**

<b>DOCUMENTS CONSIDERED TO BE RELEVANT</b>			
Category	Citation of document with indication, where appropriate, of relevant passages	Relevant to claim	CLASSIFICATION OF THE APPLICATION (Int. Cl.5)
A	WO-A-8 904 701 (BILDNER) * Figures 6a,12; pages 7-9,13 * -----	1	A 63 C 9/08
A	FR-A-2 470 618 (SCHECK et al.) * Figures 1,2,9 * -----	1	
A	DE-A-1 578 898 (SALOMON) * Figure 1; page 8, lines 1-12 * -----	1	
The present search report has been drawn up for all claims			
			TECHNICAL FIELDS SEARCHED (Int. Cl.5)
			A 63 C
Place of search		Date of completion of search	Examiner
The Hague		18 October 91	STEEGMAN R.
<b>CATEGORY OF CITED DOCUMENTS</b> X: particularly relevant if taken alone Y: particularly relevant if combined with another document of the same category A: technological background O: non-written disclosure P: intermediate document T: theory or principle underlying the invention		E: earlier patent document, but published on, or after the filing date D: document cited in the application L: document cited for other reasons ..... &: member of the same patent family, corresponding document	