

(19) (KR)  
(12) (B1)

(51) 。 Int. Cl. <sup>6</sup> (45) 2001 11 03  
F04C 2/00 (11) 10 - 0311994  
(24) 2001 10 04

(21) 10 - 1999 - 0040236 (65) 2001 - 0005445  
(22) 1999 09 18 (43) 2001 01 15

(30) 99 - 164757 1999 06 11 (JP)

(73) 가 가  
가 가  
가 4 6

(72) 가 496 - 4  
694  
가  
가 6 - 16  
가 575 - 2

(74)

:

(54)

가  
,  
, (11) (5) (11) (7)  
(7) (11) (7a) (7a) (11)  
(11a) (11b) (7b) (11a) (11b)  
(16)

2

, , , , , , ,

1 1 .

2 1 A - A .

3a .

3b .

4a

.

4b .

5 1 .

6 2 .

7 3 .

8 4 .

9 5 .

10 6 .

11 7 .

12 8 .

<

1 :

2 :

2a :

2b :

3 :

61, 162 :

17, 171, 172a, 172b, 172c :

62 - 11200

1).

63 - 230980

가

( 2).

60 - 32585

가  
( 3).

가

1 2

가

3  
가

가

1

2

가

가

가

(前半)

3

2

1

1

1

5

1 2

(1) 가

(1a)

(1b, 1c)

(1)

(2),

(3)

(4)

(2)

(2a)

(2b)

(2a)가

(1)

(2b)가

(2a)

가

(3) 2

(5),

(61, 62)

(63), 2

(7),

2

(8)

(7)

(7a)

(7b)

2

(5)

(63)

(61, 62)

2

(11)

(5) (11) (10) (12)

(12) (61, 62) (13)

(3) (61) (1)

(4) (2) (2b) (3) (61, 62)

2 (4a)가 가 , (4) (4) (7) 2 (7a) (4b)

(2) (2a) (2b)가 (4) (4) (4)

2 (4a)가 2 (7) (7a)가 (5) 5

(7a) (7b) 2 (7a)

(7b) (11) (11a) (11b) L (8) (10) (12)

(8) (5) 가

(9) (15) (1) (15)

(9) (9) (10)

(9) 가 (61, 62) (5) (10) (12)

(11) (61, 62) (13) (14) 1 (71) (1)

(15) 2 (72) (1) 가

(16) (61, 62) (16) (61, 62) (5) (8)

(8) (11b) (17) (16a) (12) (11a) (17)

(11b) (11b) (17) (16a) (11a)

(16) (11b) 3

3a (7) (8) (正弦波狀)

3b (7b) (11) L (余弦波狀)

(16) (11b) (7) (8) 1 A[ 3a

(16) A] (16) (17), (11b) 2

(16) (11b) (17), B[ 3a B] (16) (11B)

(7) (11b) L L1  
 (16) (11b) (17), ,  
 C[ 3b C] (16) (11b) L2  
 (16) (11b) (17),  
 D[ 3b D] (16) (11b)

A, B, C, D C A, B (16) (11b)

(16) (11b) L A, B, C, D

(16) (11b) 4

4a B (14) (11b)  
 (17) (16) 가  
 (16) A C (11a) A C가  
 AC (16) (11b) (17) , (16)  
 , (16) 가 (11a)

(13) 가 가 (13) (16) (11b) 가 가

(16) 가 (16)  
 가 (11a) (11a) (1)  
 1b) (16) (16) (11b) 가 가  
 , (11a)

4b A (16) (11b)  
 (17) (16) 가 (11a) 가  
 (16) D (16) (11b) (17)  
 , (16) 가 (11a) 가  
 C (16) (11b) B C (17) B C가 B

, (16) 가 (16)  
 가 (11a)

, (7b) (11) 가 (7a) 0  
 (11a) (16)

, (13) 가 가 (11b) 가 .  
 ,

11b) (13) 가 가 ( )  
 가 . , .

, .

, (16) (11) 5 .

5 (d) , (7a) (7a), (7b) (8) (a) (b)  
 , (c) , (16) (11b) (d) .

(16) (8) 3a B (17) (11b) ,  
 (17) (11b) (16) (b) (d) B .

, 0 (a) (16) (17)  
 (11b) (7a)가 2 (b) (16)  
 (17) (11b) (7a)가 (c) (16)  
 (d) (16) (17) (11b) (7a)가 2  
 (11b)

, 4a , B  
 (가 ) ,

, 가 (加振) ,

, 2 6 .

2 (8) (17) 가 1 .

6 (d) , (7a) (7a), (7b) (8) (a) (b)  
 , (c) , (16) (11b) (d) .

(16) (8) 3a A (11b) (b) (17) (16b) (d) A

(16) (17) (11b) 0 (a) (17) (11b) (7a)가 (b) (17) (11b) (16) (11b) (7a)가 (c) (16) (11b) (11b) (7a)가 (d) (17) (11b) (16)

(가 4b ) A

3 7 (7b) 1 (7a) (8) 2 (17b) (16) (11b) 1 (7a), (7b) (a) (8) (a) (b) (d) (c) (16) (11b) (d) (a)

3a B 3b C (7b) (8) (16) 1 (17a) 2 (17b) (11b) (b) (d)

6) 2 (16) (11b) 0 (a) (16) 2 (17b)가 (17b)가 (7b) (7b) L1 (7a)가 (17a) 2 (17b)가 (17a) 2 (17b)가 (16) (11b) (17b)가 (16) (11b) (7a)가 (c) (16) (11b) (16) (11b) (7a)가 (d) (16) 2 (17b)

(가 4b ) BC

4 8 (61) 가 3 (16) (7b) 1 (17a) (8) 2 (17b)



8 (d) (7a) (16) (11b) (7a), (7b) (a) (8) (a) (b)

(c) (d)

3a A 3b C AC

(7b) (8) (16) 1 (17a) 2 (

17b) (11b) (b) (d) (16) (16) (11b)

AC

0 (a) (16) 2 (17b)가

(16) (11b) (7a)가 (7b) L1

1 (b) (16) 2 (17b)가 (16) (11b)

(7a)가 (c) (16) (11b) (7a)가

(7b) L1 (d) 1 (17a) 2 (17b)

(16) (11b)

4a AC

(가 )

5 9

5 (16) (17) (7b) (16) (11b)

9 (d) (7a) (16) (11b) (7a), (7b) (a) (8) (a) (b)

(c) (d)

3b D (7b) (16) (16)

(11b) (11b) (b) (d) (16)

(11b) D

0 (a) (17) (11b)

(16) (11b) (7a)가 (7b) L2 (b)

(17) (11b) (16) (11b) (7a)가

(c) (16) (11b) (7a)가 (7b)

L2 (d) (17) (11b) (16) (11b)

4b D

(가 )

6 10

가 6 , (7a) (7b) , (7b) (5)  
 , 5 (7b) (7a) 5 . ,  
 , 7 11 .  
 7 (161, 162) , (161, 162)  
 (161) (61) (161) (11b)  
 (5) (8) (61) (171) . , (162)  
 (63) 1 (172a), (162) (11b) (7b)  
 (63) 3 (172c) (8) (63) 2 (172b), (5)  
 11 , (7a) (7a), (7b) (8) (a)  
 (d) . , (161, 162) (11b) (a)  
 (b) (c) , (d) (a)  
 B 3a A 3b C AC , 3a  
 (162) 4 (7b) (8)  
 (11b) , (161) 1 AC , (172a, 172b, 172c)  
 (11b) . B (171)  
 , B 4a (가 ) , AC  
 , 8 12 .  
 8 (161) (11b) (162) (11b)  
 7 .  
 12 , (7a) (7a), (7b) (8) (a)  
 (d) . , (161, 162) (11b) (a)  
 (b) (c) , (d) (a)  
 2) 2 3a A , 3a B 3b C (16  
 (161) 3 (7b) A (171, 172c) (8) (11b) ,  
 BC (172a, 172b) (11b) (11b)

, BC

4b

(가 )

A

,

가

, 2

1

,

,

.

,

(16)

(11b)

(13)

가 가  
(11b)

(13)

가 가

16)

(11a)

(11b)

(16)

(

(11b)

(16)

가 가

(11a)

(16)

,

(16)

가

가

(11a)

11b)

가,

(7b)

(11)

L 가

(7a)

(

(16)

,

(16)

(11b)

(17)

(8)

(8)

(17)가

(16)

(11b)

,

(16)

(11b)

(17)

(7b)

(7b)

(17)가

(16)

(11b)

,

(16)

(16)

(11b)

(16)

(11b)

가

(57)

1.

, , , , , .

2.

, , , 가 .

3.

1 2 , 가 . 가

4.

3 , .

5.

1 2 , .

6.

1 2 , .

7.

4 , .

8.

1 7 , .

9.

1 7 , .

10.

1 7

11.

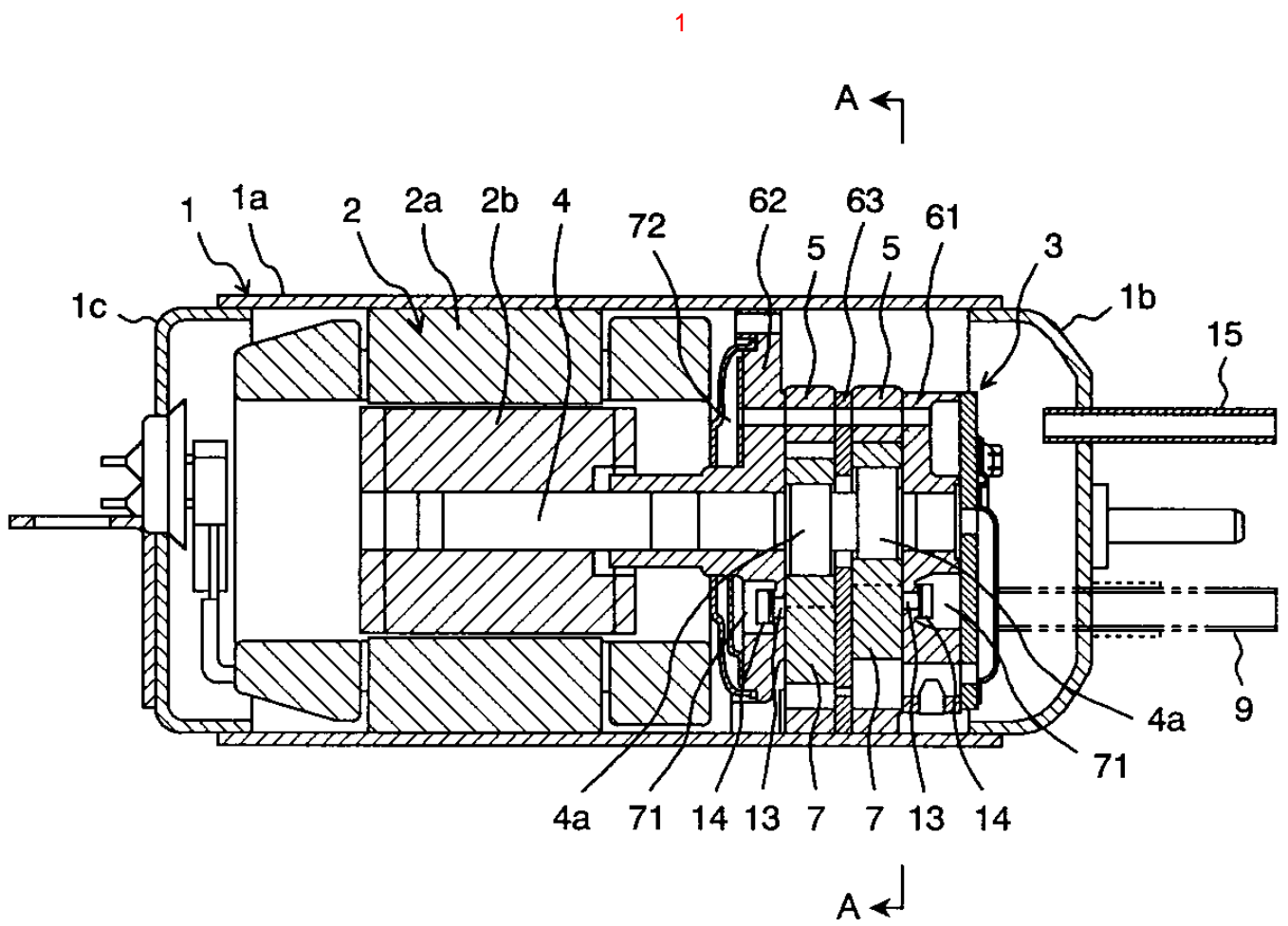

2

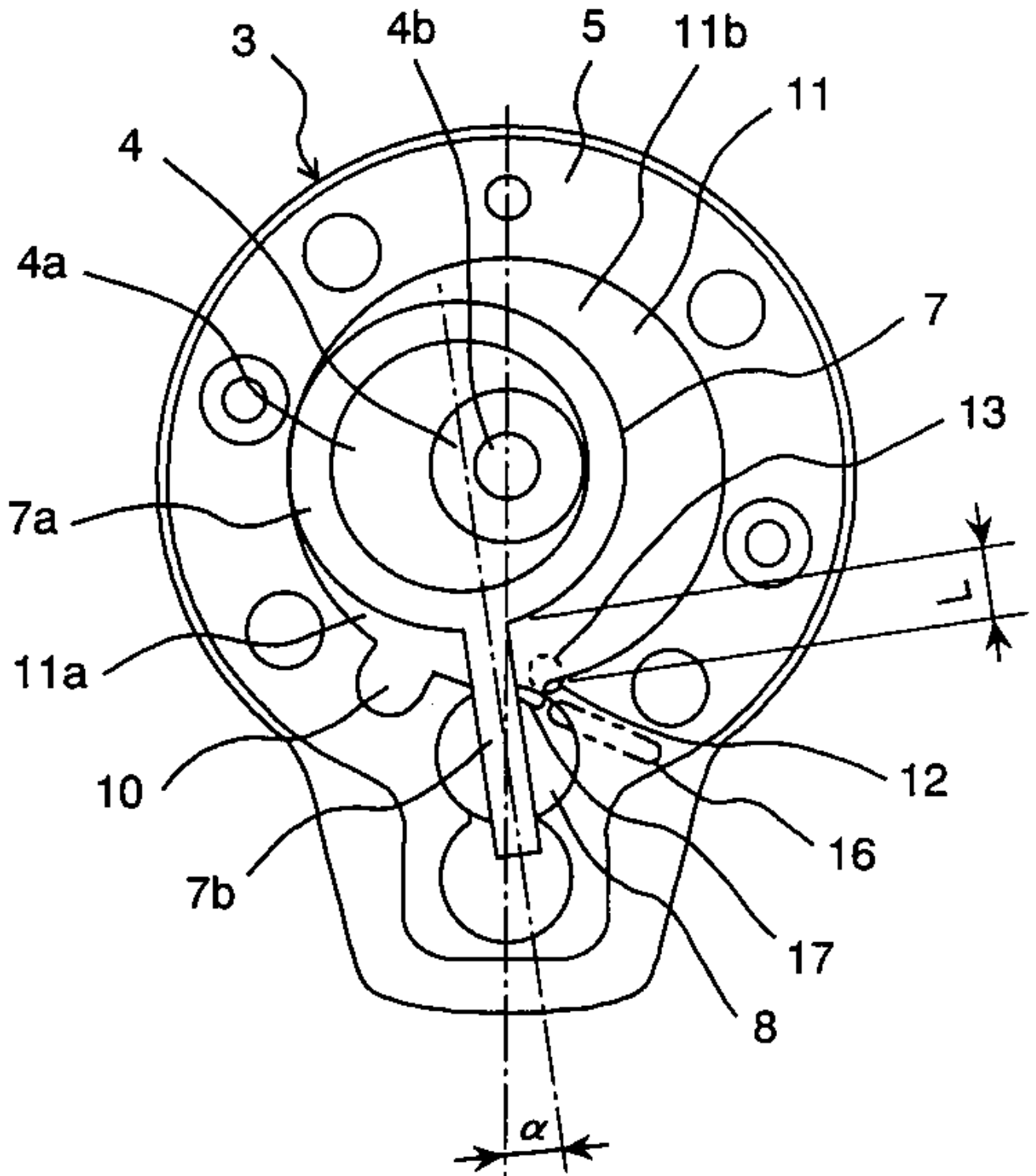

3a

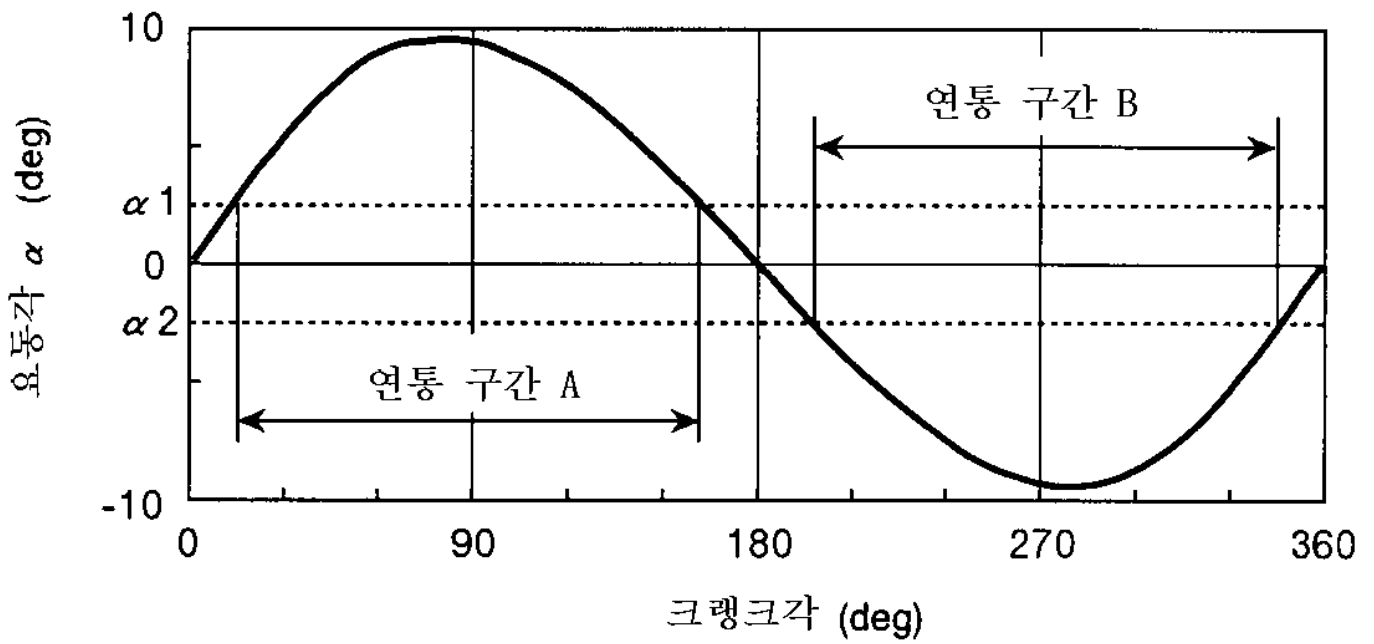

3b

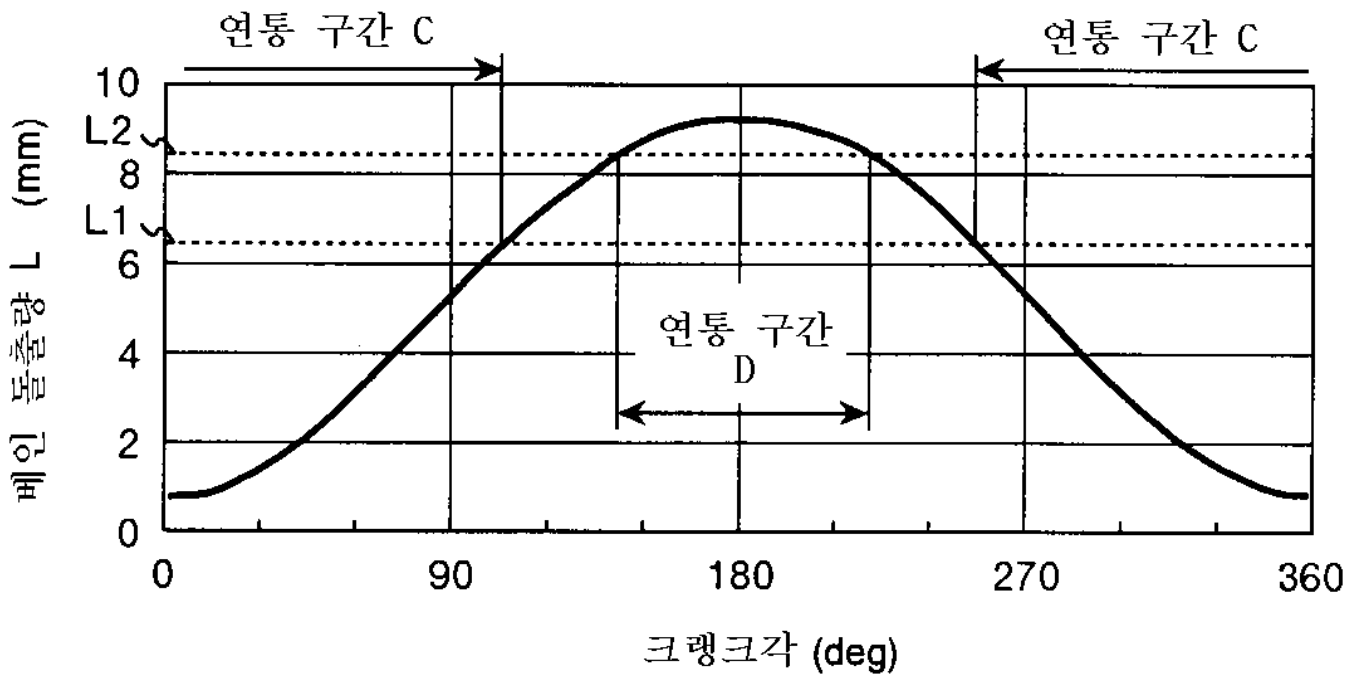

4a

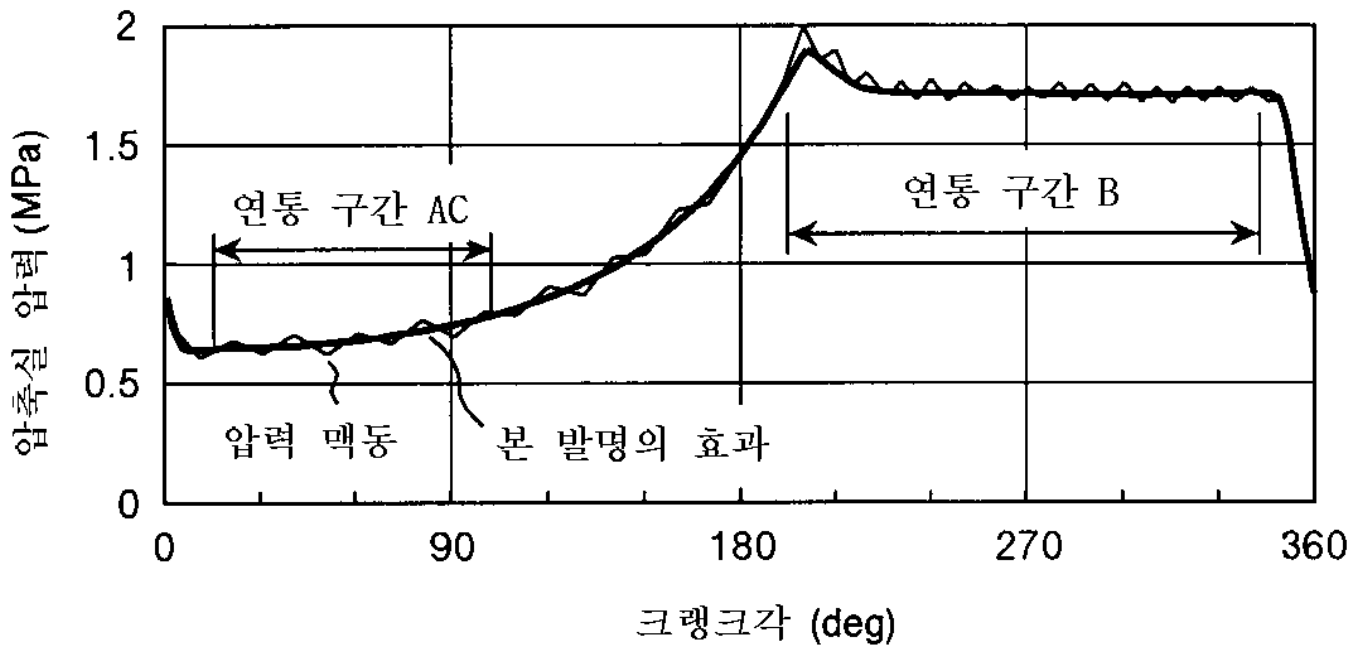

4b

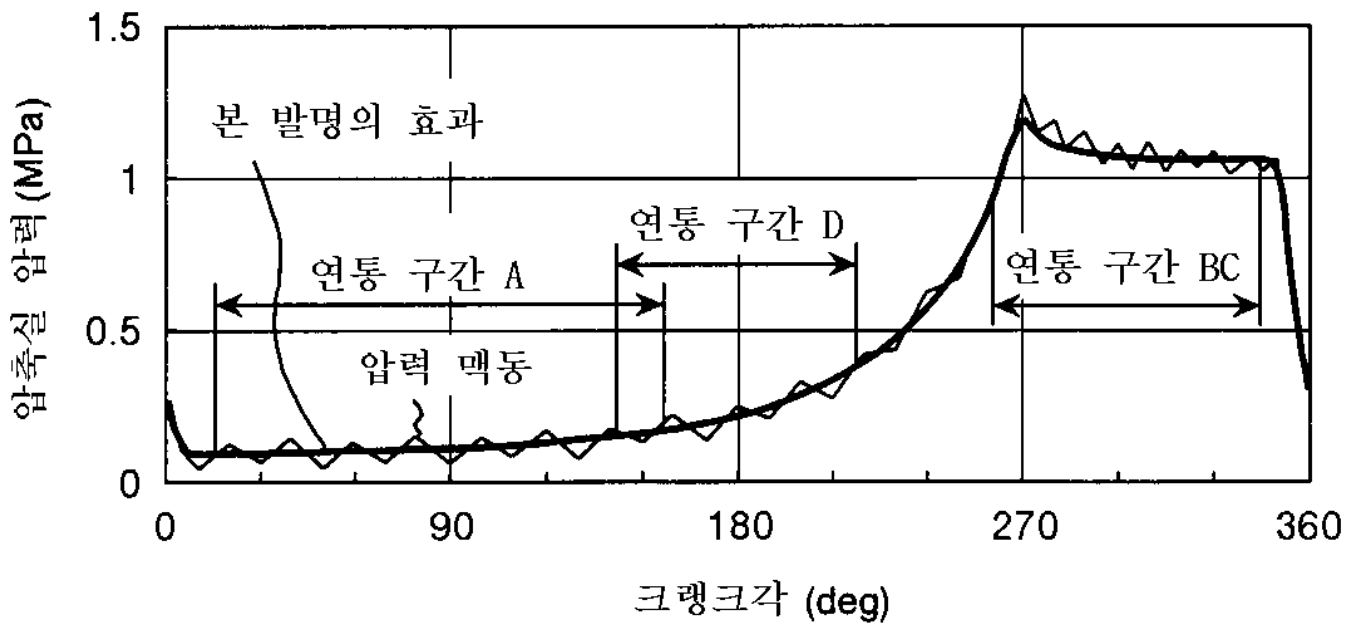



5

(a) : 크랭크각 0



(b) : 구간 B 연통 개시

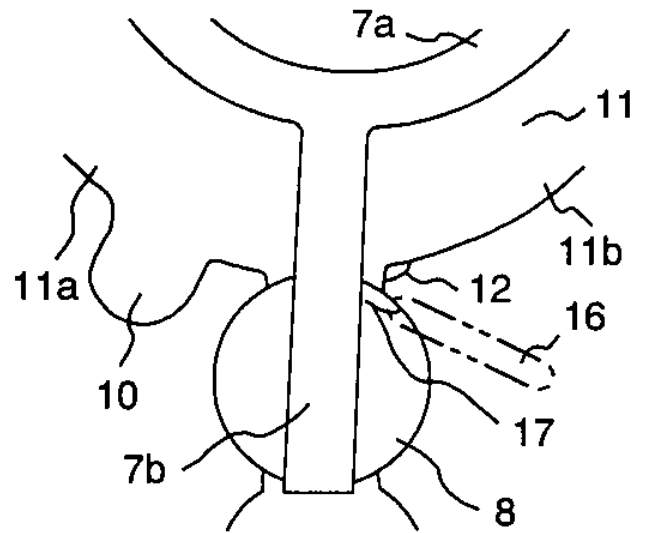
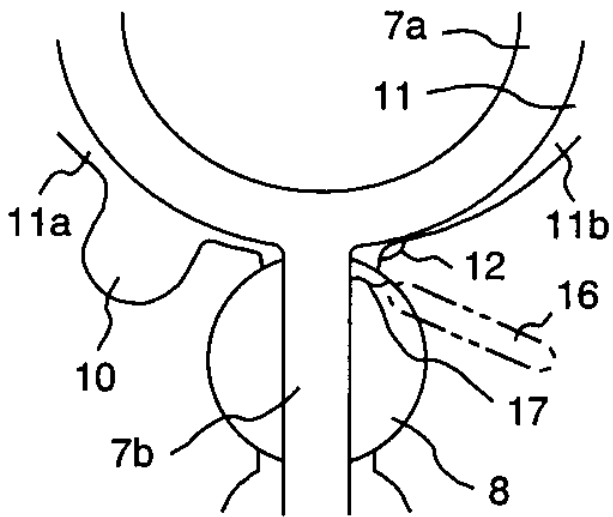

(d) : 구간 B 연통 종료



(c) : 구간 B 연통중

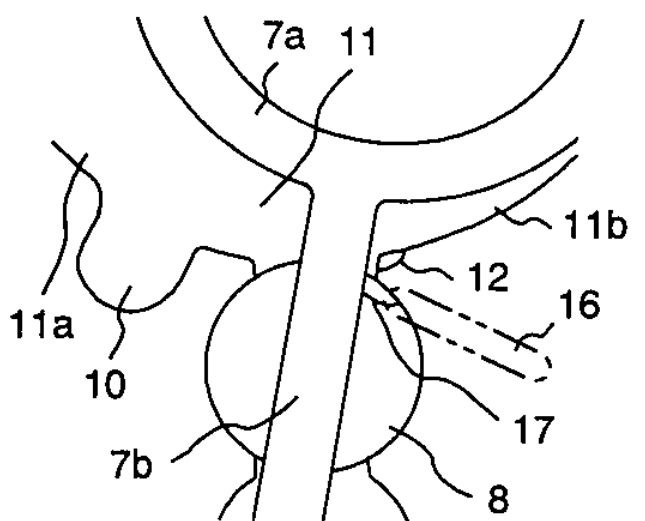
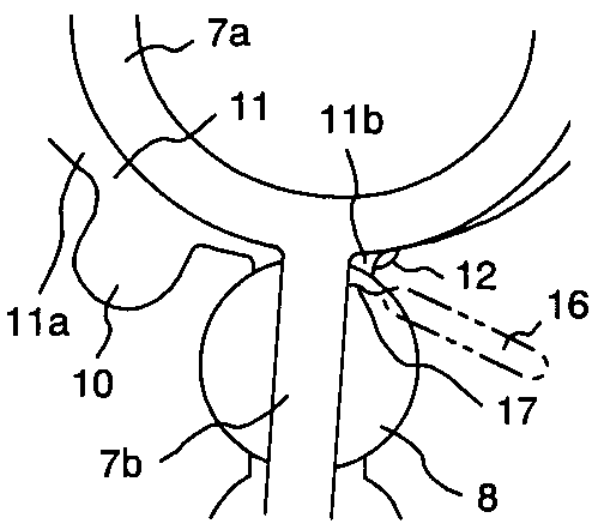

6

(a) : 크랭크각 0



(b) : 구간 A 연통 개시

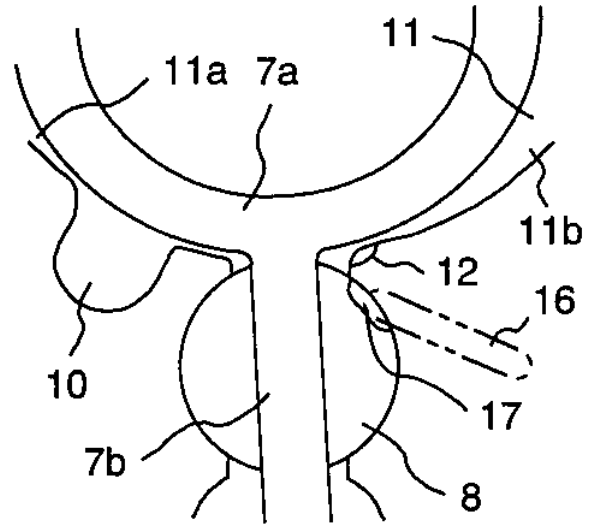
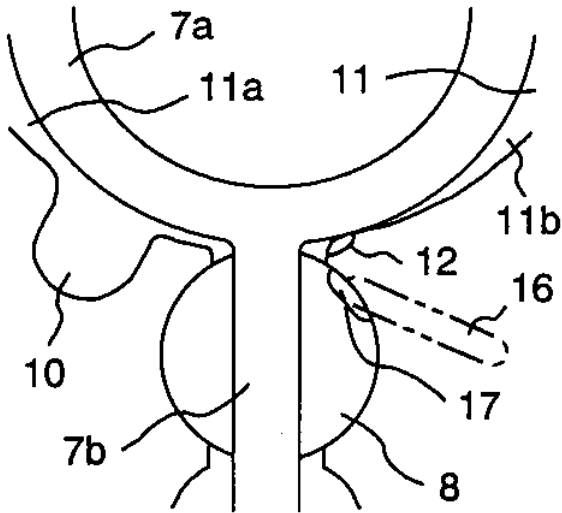

(d) : 구간 A 연통 종료



(c) : 구간 A 연통중

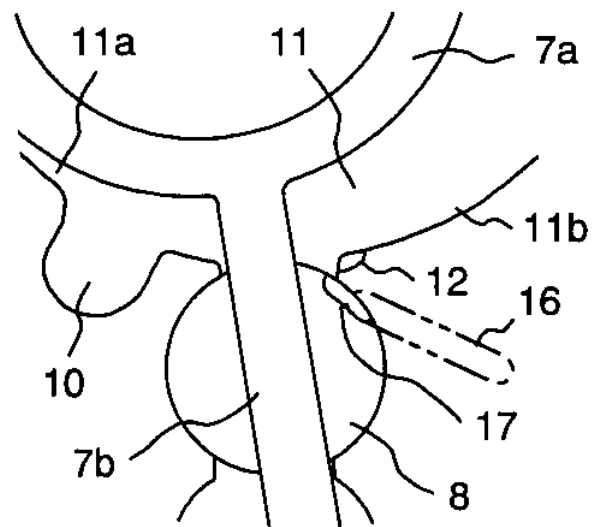
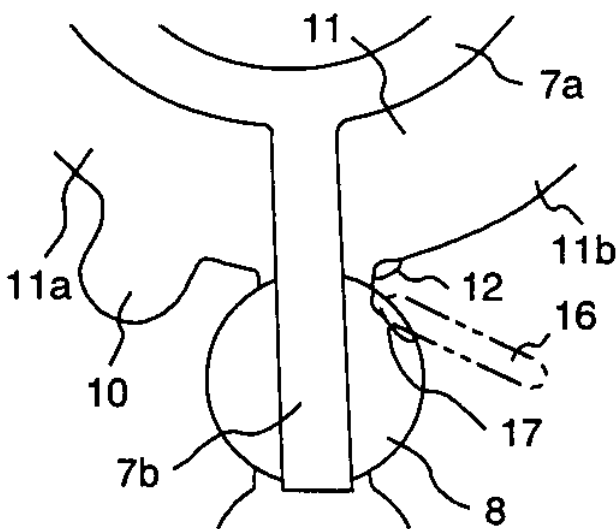

7

(a) : 크랭크각 0



(b) : 구간 BC 연통 개시

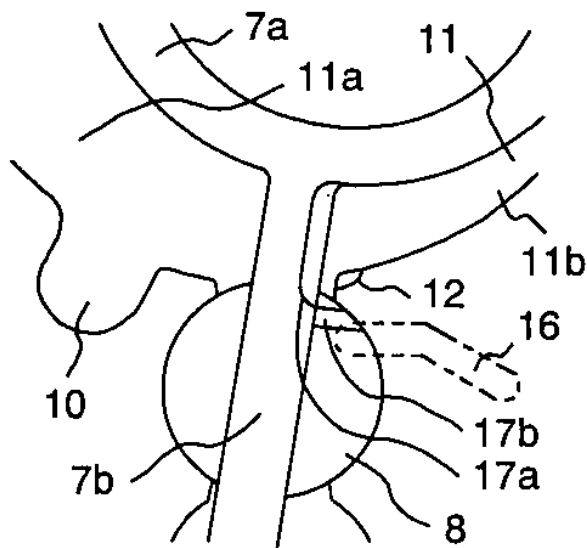
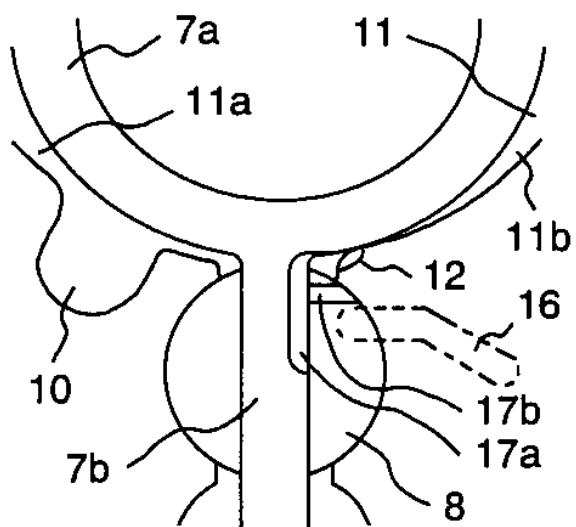

(d) : 구간 BC 연통 종료



(c) : 구간 BC 연통중

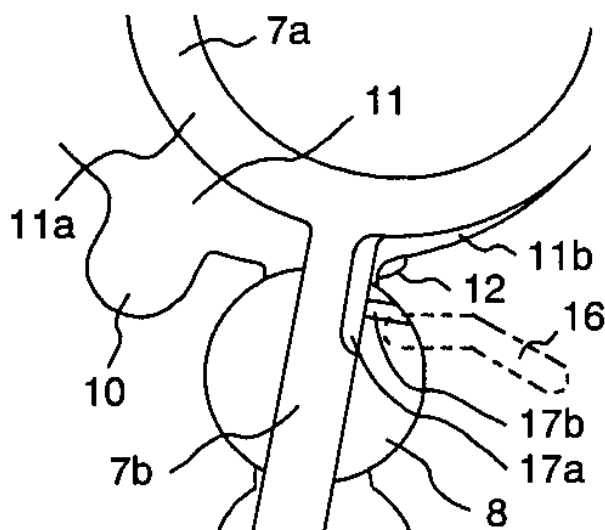
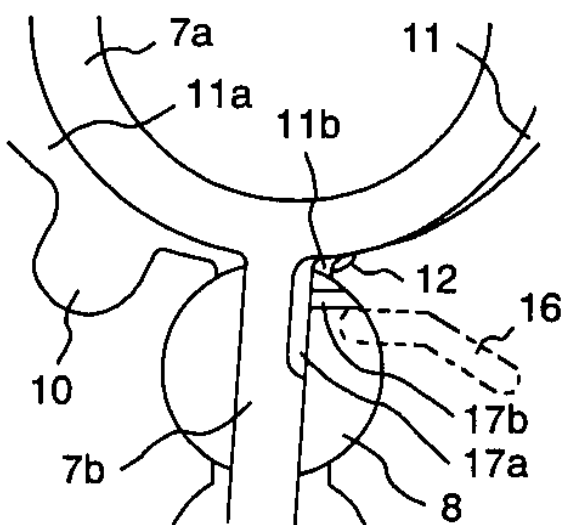

(a) : 크랭크각 0



(b) : 구간 AC 연통 개시

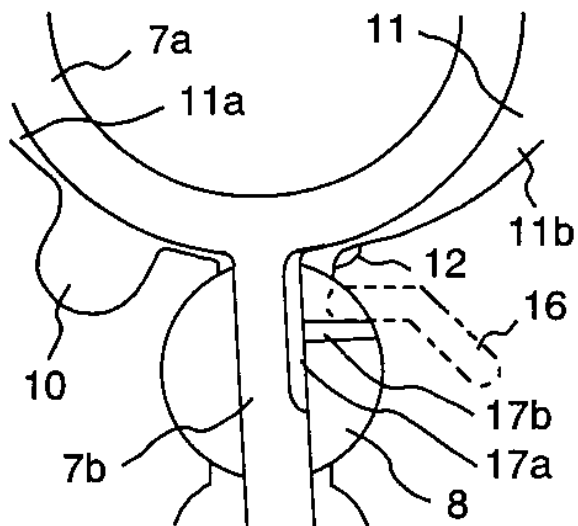
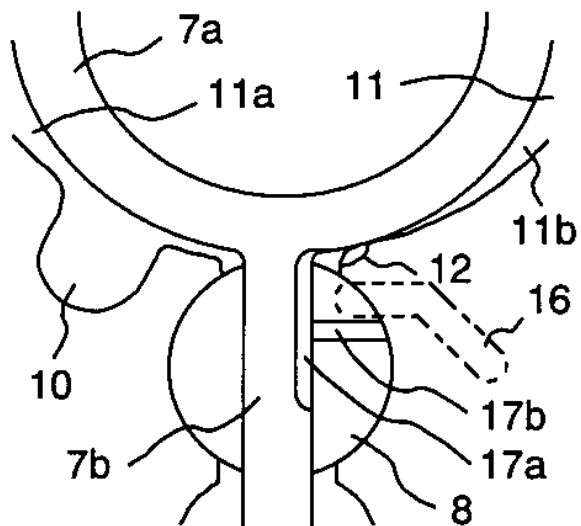

(d) : 구간 AC 연통 종료



(c) : 구간 AC 연통중

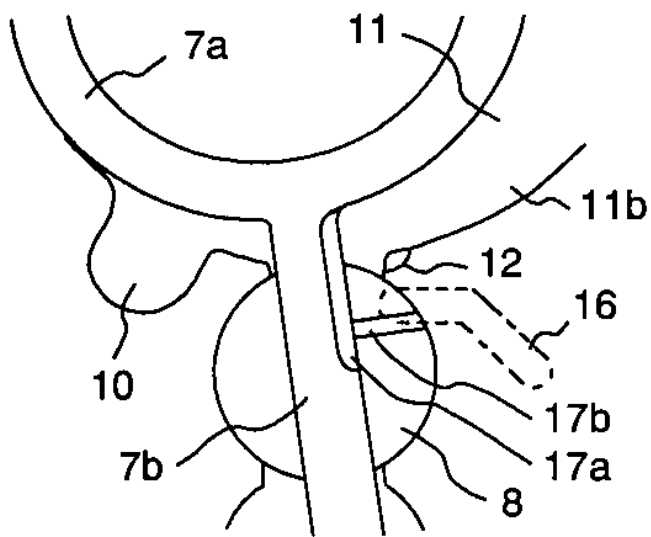
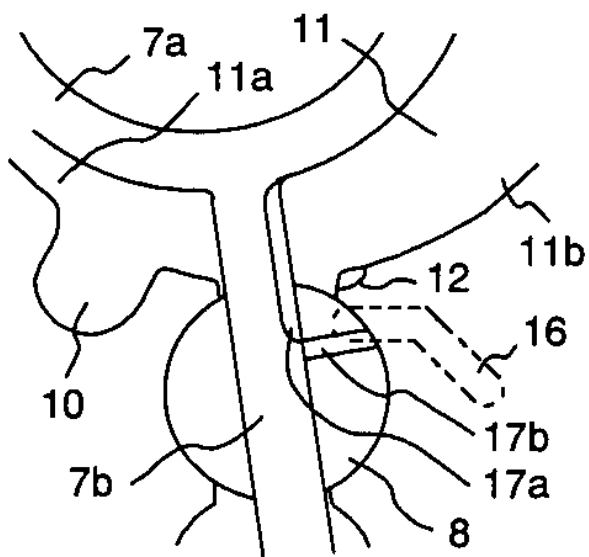

(a) : 크랭크각 0



(b) : 구간 D 연통 개시

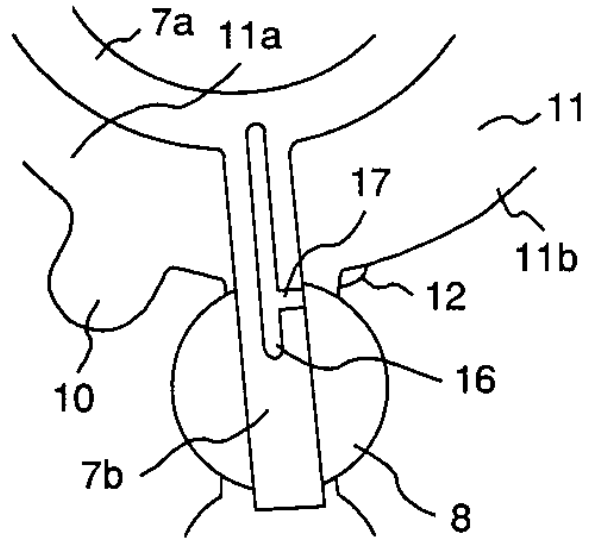
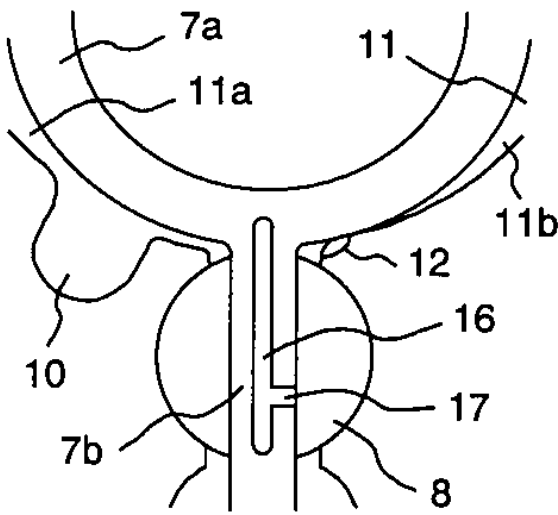

(d) : 구간 D 연통 종료



(c) : 구간 D 연통중

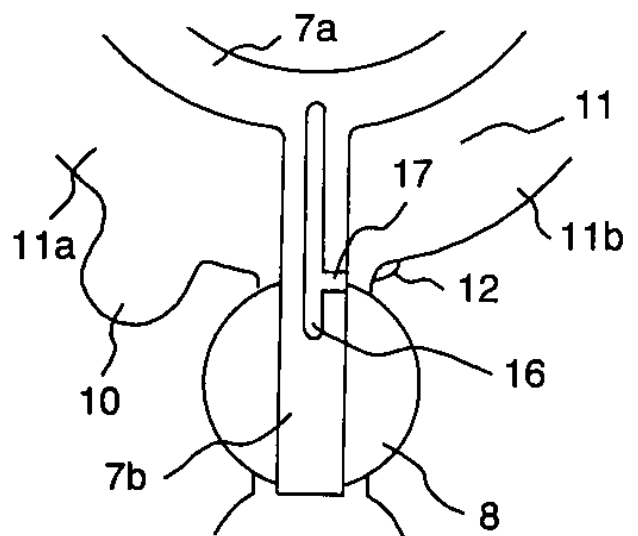
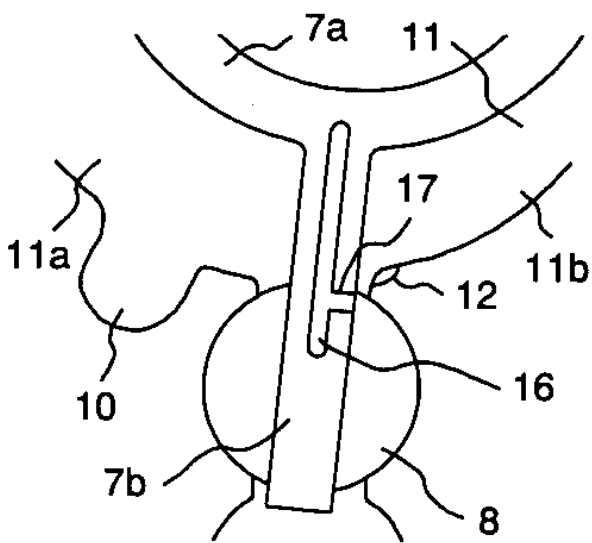

10

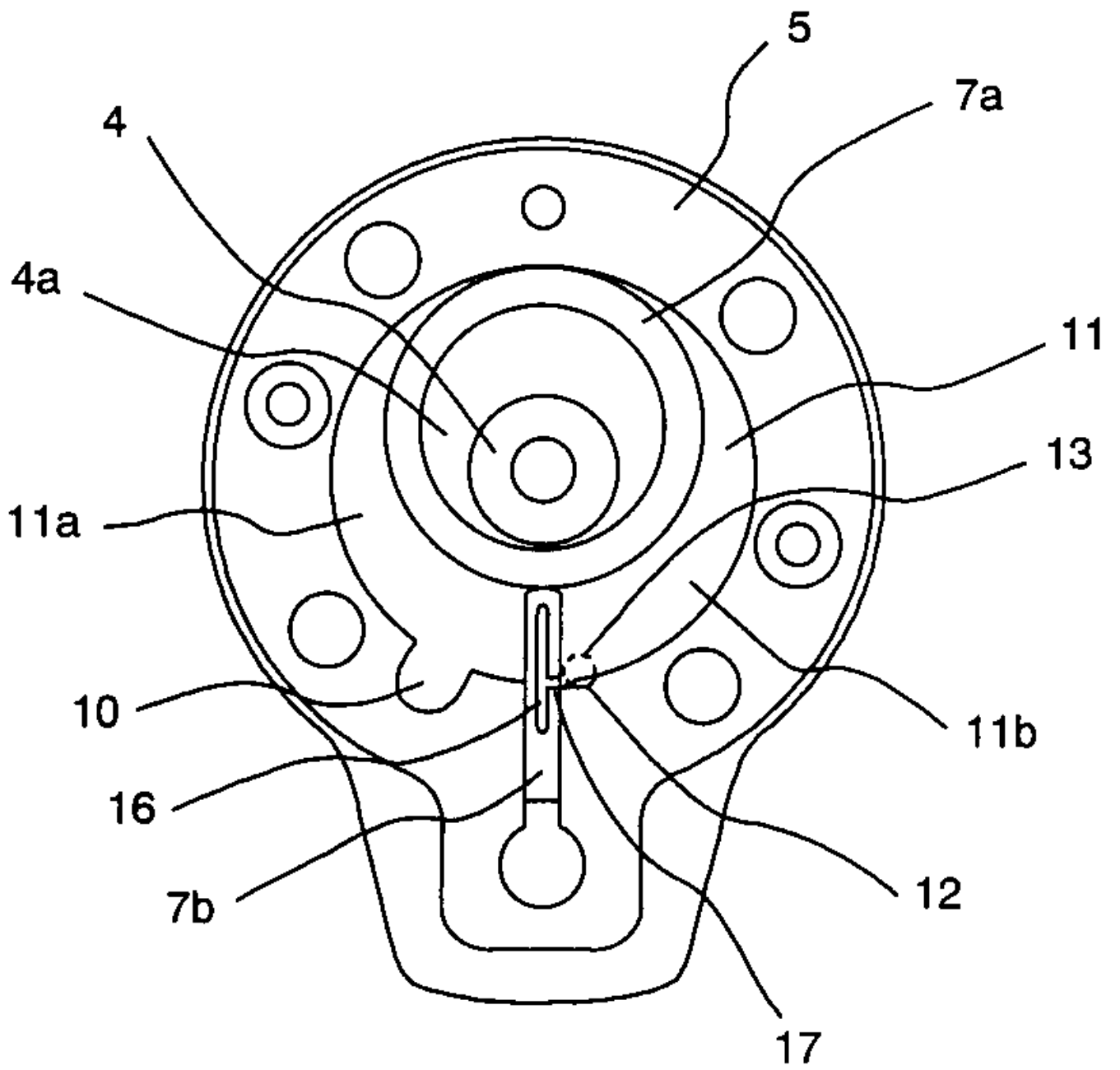

11

(a) : 크랭크각 0



(b) : 구간 AC 연통중

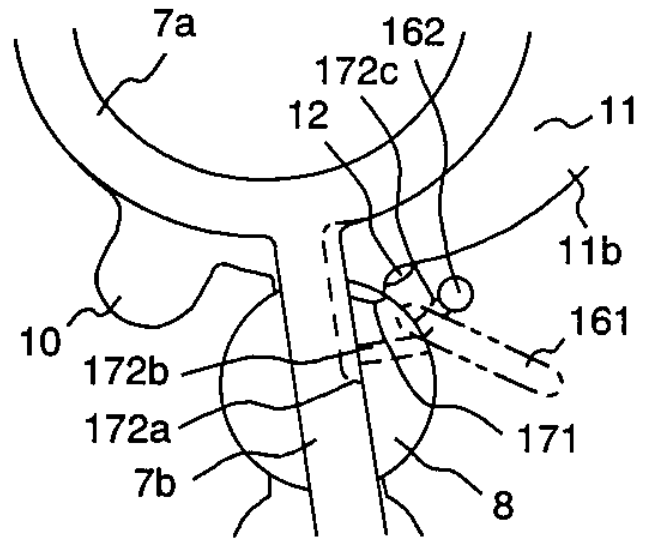
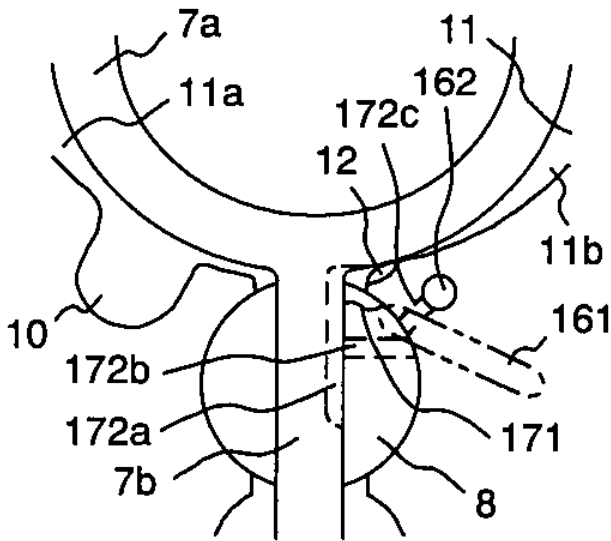

(d) : 구간 B 연통중



(c) : 비연통중

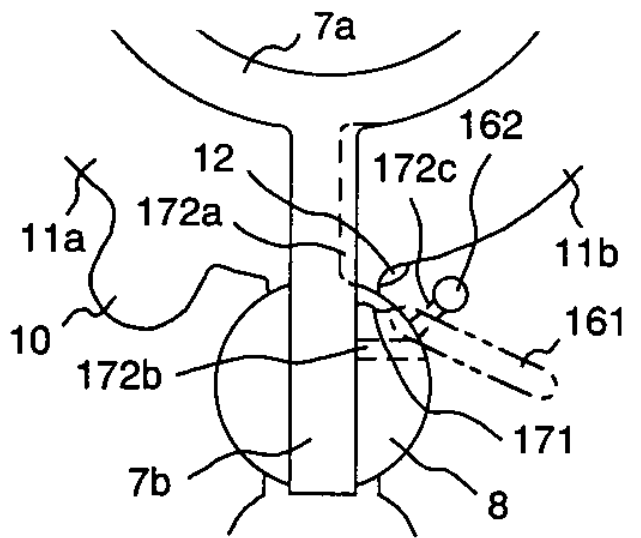
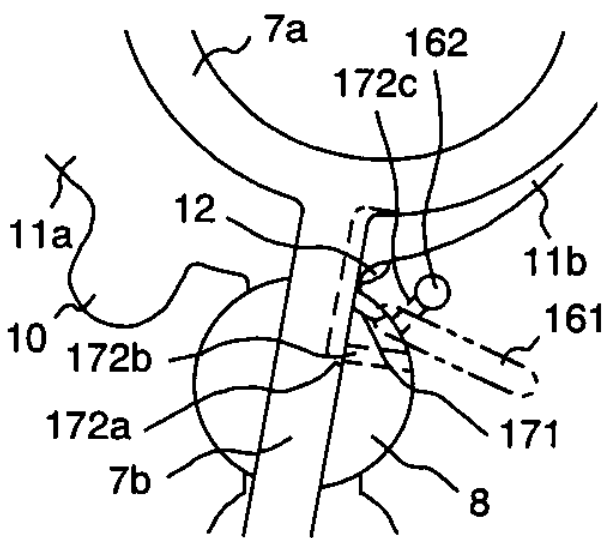

12

(a) : 크랭크각 0



(b) : 구간 A 연통중

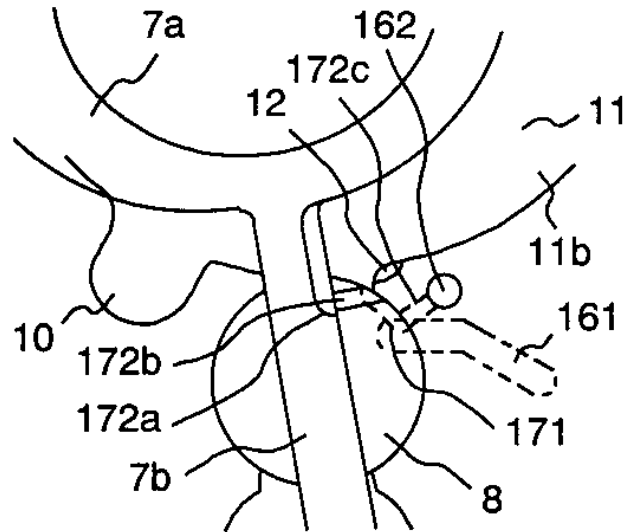
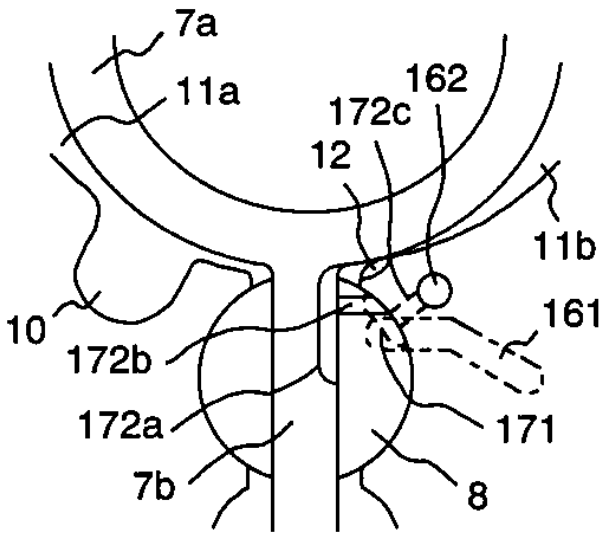

(d) : 구간 BC 연통중



(c) : 비연통중

